



Volo<sup>®</sup>

## Planning Guide

March 2022



# Contents

Your Vision, Your Volo.....	2
Seven steps to specification.....	2
Design and Installation Planning.....	3 - 8
Volo Movable Walls Elements .....	9 - 24
Unframed Wall	
Frameless Glass Wall.....	10 - 13
Glass Inserts.....	11
Framing Elements .....	12
Conditions .....	13
Framed Panels	
Crown and Base Styles.....	14
Panel Frames.....	15
Sliding Door Sections .....	16 - 21
Frameless Glass Sliding Door Section .....	17
Aluminum Framed Single Sliding Door Section .....	18
Aluminum Framed Double Sliding Door Section .....	19
Wood Single Sliding Door Section .....	20
Wood Double Sliding Door Section .....	21
Sliding Door Dimensions .....	22
Swing Door Frame.....	23 - 24
Tiles.....	25 - 27
Doors/Door Hardware.....	28 - 32
Connectors .....	33 - 39
Horizontal Connectors .....	33 - 34
Vertical Connectors .....	35 - 39
Wall Starts.....	35 - 36
End of Run Connectors.....	36
Inline Connectors .....	37
Condition Connectors .....	38
Volo to TrendWall Connectors .....	39
Power and Data .....	40 - 46
8 Wire System .....	40
Accessing Building Power .....	40
Vertical Power/Data Routing .....	40
Horizontal Power/Data Routing .....	41 - 43
Power Specification - Steps and Calculations.....	44 - 46
Acoustics .....	47 - 48
Installation Overview .....	49 - 57
Frequently Asked Questions .....	58 - 59
Installation Instructions List.....	60

## Your Vision, Your Volo®!

---

What's your perfect space? Whatever your vision, Volo brings it to life with speed, ease and practicality.

Volo Movable Wall is a unitized, non-progressive panel system that is quick to specify, install and reconfigure. Volo is designed and planned like a frame and tile system, but panels ship unitized and ready to install.

Volo offers a creative range of surface material options for varying degrees of privacy and function. Volo can create the aesthetic of fine custom millwork, or the simple functionality of drywall construction. Plus, the versatile panel sizing conforms to any space dimension requirements. Personalizing Volo Walls couldn't be easier.

**NOTE:** The digital AP binder includes the marketing and technical documents you need to sell, specify, and respond to customer requests for documentation. Dealers and customers can download it from the Documents portion of Design Resources. See details in the FAQ section, page 49.

Seven steps to specs:

1. Pre-qualify the project
2. Select Crown and Base styles
3. Select the Panel Frame style to match the Crown and Base style
4. Select Tile sizes, materials and specify tile positions on the frame
5. Select Sliding or Swing Door style and Door Hardware
6. Specify Frame Condition Connectors
7. Specify Electrical and Data components

## Design and Installation Planning

---

Proper planning and preparation is key to successful and profitable Volo projects. **Take the time to fully understand the customer's needs and requirements.**

**IMPORTANT:** Use the Project File tool to pre-qualify the project and select the product that suits the client's price parameters. Have their Request for Bid documentation on hand when performing site surveys and during design and installation. It is critical to document all decisions made from start to finish.

### Trendway field support

Trendway offers Field Technical Support for a nominal fee. Approved Trendway Technicians can take field measurements, train and assist during the actual installation at the customer location. Using this resource assures accurate product design and planning, as well as fast, expert installation. Contact the Trendway Architectural Product team or Field Technical Support team for more details.

**NOTE:** When planning for a Volo application that is not attached to a ceiling, the Freestanding Volo Kit contains the parts needed to effectively provide the additional structural integrity required for freestanding capability. Order part number VFCK for the kit of parts. **This method adds the rigidity necessary for a freestanding wall up to a 12' run. If you desire other dimensions, contact your Trendway Architectural Specialist and design team for help.**



Freestanding Volo applications require the Volo Freestanding Crown Kit (VFCK).

**Important:** Reveal Wall Starts and wall-hung components CAN NOT be installed on freestanding applications.

**NOTE:** Panels must be securely braced during installation of Volo freestanding applications. Please refer to instruction sheet [INS659](#) for proper installation sequence.

## Site survey and verified field measurements

- A thorough pre-installation survey is required.
- Ensures fast, accurate, effective space planning and design.
- Allows effective scheduling for timely completion, no lost time on the job.
- Improves profit through problem-free installations, happy customers and return business.

## Floor plans

- Accurate floor plans with key dimensions and conditions within the building architecture are essential. They should include:
  - a. Overall space dimensions
  - b. Wall locations and distance from columns
  - c. Wall runs that terminate flush with building wall surfaces
- Door locations for ceiling height measurements are crucial for accuracy — door frames offer just  $\pm 1/2''$  of adjustment, and Full Height Doors are limited to  $1/4''$  of adjustment.
- Define the location of the partition run. Volo Vertical Connectors are 2-1/2" thick, so using construction lines that are offset by 1-1/4" is a good place to start (center of panel). The thickness of a panel varies depending on the tiles used, but Wall Starts and condition connectors are consistently 2-1/2" thick.
- Once the desired location of the walls is determined, you can begin the office layout.
- The framing layout and elevations must be developed using 20/20 CAP planning software and Panel Builder supported with Trendway symbol libraries.

### **Ceiling height - a critical measurement**

- **Measurements must be taken on the final site floor treatment (after carpet or other flooring is installed) for accuracy.**
- **IMPORTANT: Measure ceiling height at every door location.**
- Measure ceiling heights every 10', approximately along the line the wall will run.
- If there is variance greater than  $1/2''$  over a 10' measurement, take additional measurements at 5' intervals.
- Note heights accurately on the floor plan.

## Site Ceiling

Determine the installation site's ceiling type and grid (if applicable), which will determine attachment requirements. If you are not certain, or encounter a different type of ceiling than described here, send a photo to your Trendway Technical Support team for assistance.

Information you will need:

- Identify ceiling type: Grid and Tile, Gypsum or other material (e.g. wood). This will determine the type of ceiling anchors you require.
- Identify Grid ceiling tile type (if applicable):
  - Flat
  - Tegular/Reveal (see next bullet point)
  - Armstrong Silhouette
- Tegular/Reveal grids require the use of Grid Blocks for installation. Determine if the Tegular tile has a 1/4" or 3/8" tile recess dimension (how high it sits proud of the grid). There are Grid Blocks for Traditional and Reveal style crowns. Specify the 1/4" or 3/8" Block, depending on the tile recess. Specify one Block for every 2' of panel run, or 6 for every Crown section on order.
- Identify Grid type (if applicable): 1" Standard or 9/16" Thinline.

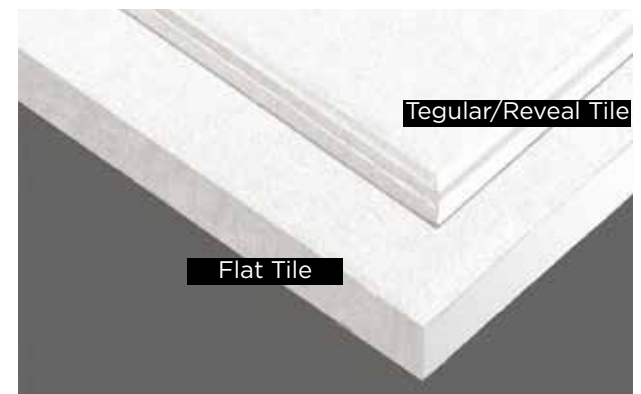
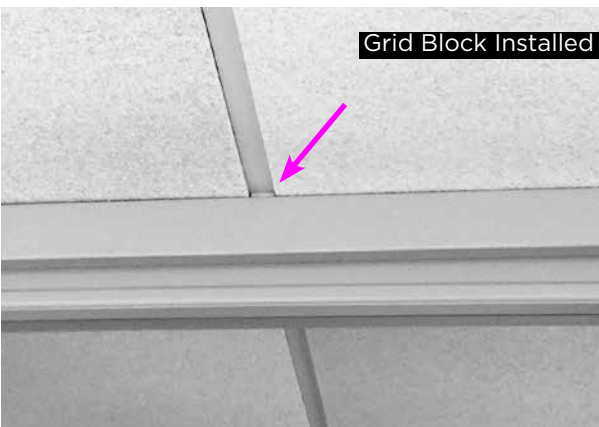

## Site Ceiling

Volo Crown elements are secured to the ceiling or ceiling grid using appropriate fasteners.

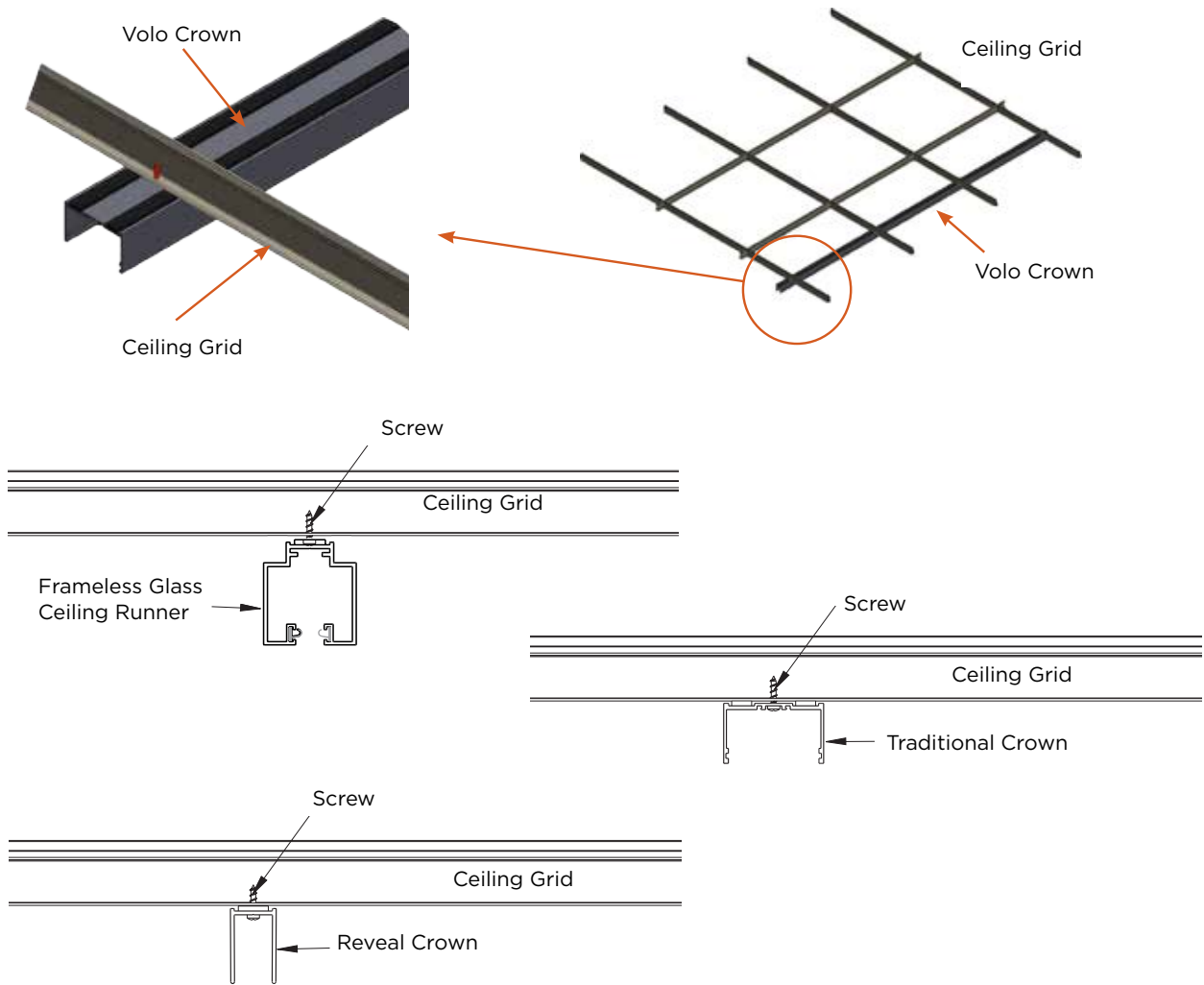

Armstrong Silhouette ceiling requires the use of Grid Clips to attach the Crown to the grid, available for order from Trendway (Special part number 404765).



Grid Clip for Armstrong Silhouette Ceiling





## Physical building conditions

Site conditions may affect wall placement or require special planning to accommodate. Inspect the site and note any situations that may impact or interfere with the layout, or require special wall connection treatment due to site wall conditions. These may include:

- ADA requirements
- Building walls and columns
- Building electrical and data access
- Convector Units (baseboard heating units)
- Exterior Wall Start Conditions
- Air-handling diffusers
- Floor Type HVAC Supply and Return Grills
- Light fixtures
- Soffits
- Sprinkler heads
- Unusual Baseboard Configurations
- Wall or floor outlets
- Window conditions
- Ceiling type
- Flooring type
- Window sill and drapery pockets

Ask the customer to look for obstructions before the product is ordered. It will be their responsibility to remove obstructions or relocate the wall.

Once the site observation and measurements are complete:

- Identify any design modifications that should be anticipated due to site conditions.
- Review modifications with the designer before any design or layout begins
- Review modifications with the installers before installation work begins.

Once the design is finalized, it's essential to do a thorough onsite verification of the installation drawings to actual site dimensioning prior to installation.

## Compliance with relevant regulations

Before any work is performed, be certain you are in compliance with local and/or Government project or contract regulations. These may include, but are not limited to:

- Building Codes
- Building Permits
- Test data or product sample submissions for approval
- Certificates of Occupancy
- Labor requirements (security clearance, trade union jurisdictions for tasks, etc.)
- Verification of seismic bracing if required by local code

NOTE: ADA requires power outlets accessible within the range of 15" to 48" above the floor. For Volo this requires hard-wired vertical power. Some municipalities will allow an ADA outlet every 10-20 outlets in a work space and some municipalities may require all outlets to be ADA accessible. Contact your local authority for clarification.

### **Installation planning checklist**

- Has the Project File tool form been completed and all Request Forms submitted?
- Where will material be received, and who will receive?
- Where will material be stored?
- Are there any access or security rules governing time that installation may take place?
- Where are walls to be installed?
- Is the environment (i.e. heat, light, humidity, etc.) satisfactory?
- Are there any power complications?
- Are there any material handling obstacles (e.g. elevator/stairwell/corridor dimensions)?
- What preparation is required for cleanliness of metal trim and panel cutting?
- Are there any special tools or equipment required? (See Recommended Installation Tools list on page 40.)
- Are there complications or timing conflicts with other trades?
- Are floor loading limitations satisfactory?
- Ceiling type (Gypsum, drop Flat, drop Tegular/Reveal etc.)?
- Is there anything on this job that requires extraordinary preparation?

### Post-Installation

- Obtain post-installation verification of product delivery, ownership, and security.
- Complete any punch list items and “turnover” procedures (Certificate of Occupancy, etc.).
- If promotional photography is desired, obtain permission (signed release) and schedule.

### NOTE: Custom Product/Specials

Trendway can support some kinds of custom product requests. See the FAQ section on page 51 for details.

# Volo Movable Wall

Volo Framed Panels consist of five basic elements:

- Panel Frames
- Door Sections, Frames and Doors
- Tiles
- Connectors
- Electrical

Volo Frameless Glass Wall consists of two basic elements:

- Framing Elements
- Glass Inserts

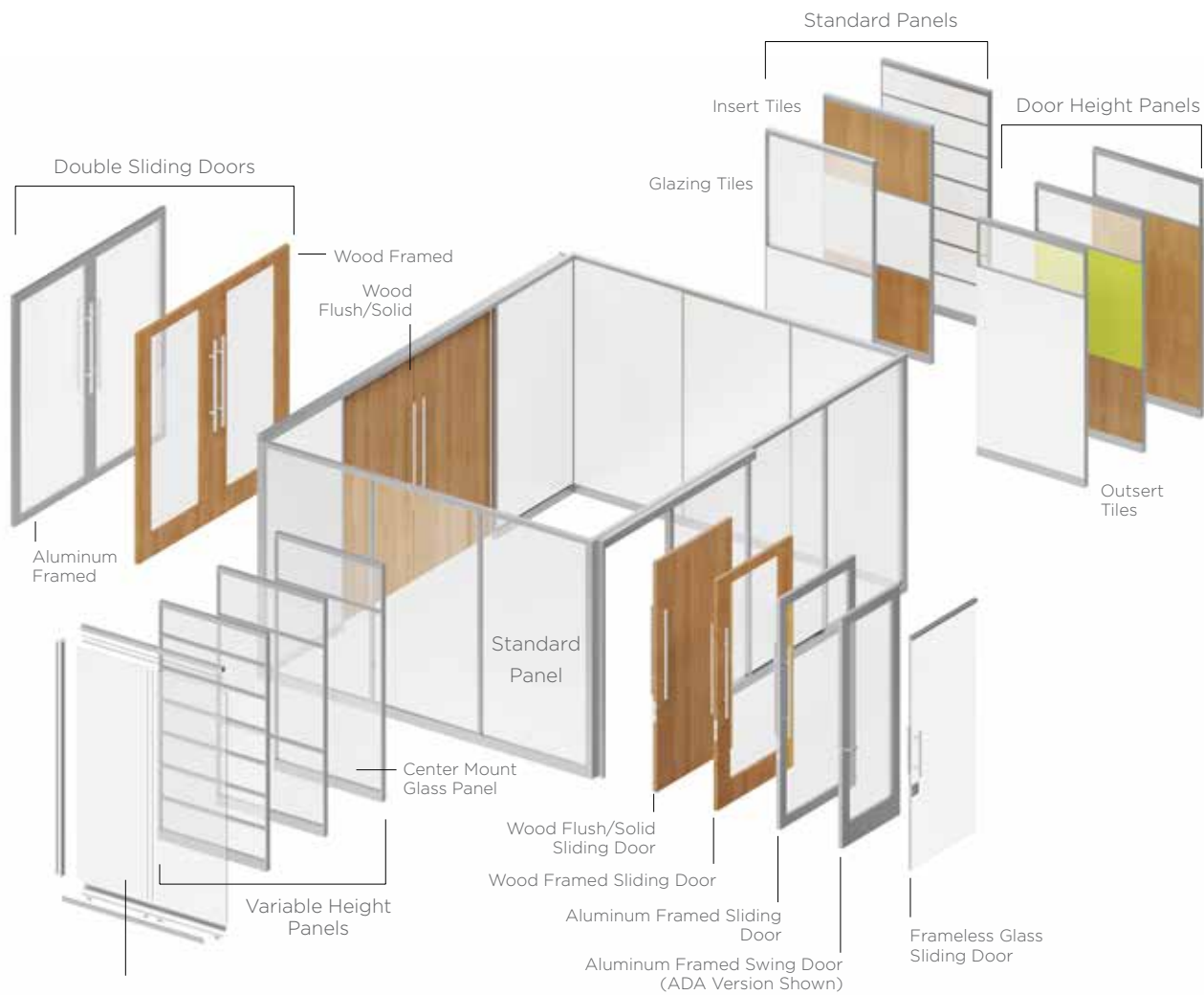

Frameless Glass Wall, a kit of parts including Glass Inserts and Framing Elements

## Frameless Glass Wall

Frameless Glass Wall is specified and used as a kit of parts consisting of Inserts and Framing Elements. These include Ceiling Runner, two-part Floor Runner Vertical Adapters and 1/2" or 3/8" tempered Glass Inserts.

Frameless Wall allows up to 2" of vertical adjustment per Insert span. Frameless Walls are not powered.

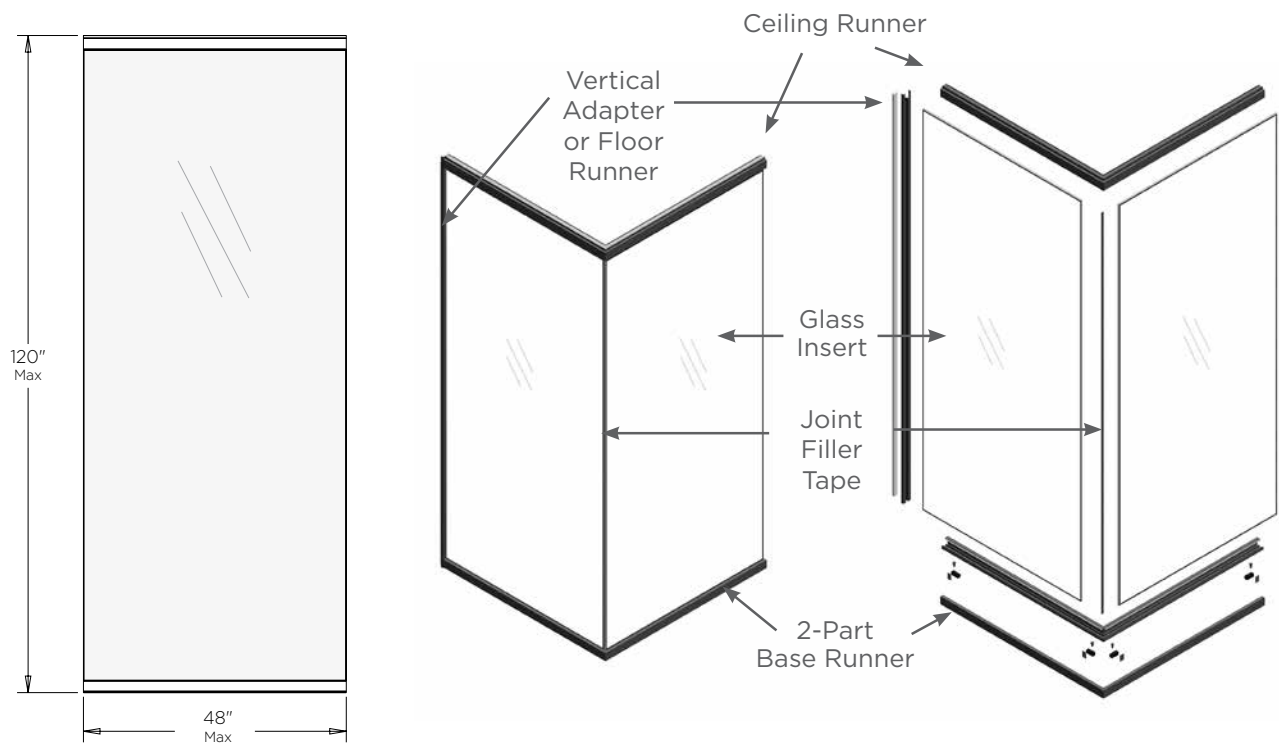

**Glass Deflection Tolerances — Industry Standards**

	3/8" Glass	1/2" Glass
8'	9/32"	13/64"
9'	11/32"	9/32"
10'	N/A	3/8"

### Important Note on Glass Deflection

Due to its intrinsic nature, glass naturally displays a degree of deflection (bowing). Volo Frameless Glass is no exception, however any deflection that may occur is well within accepted tolerances (see the chart left).

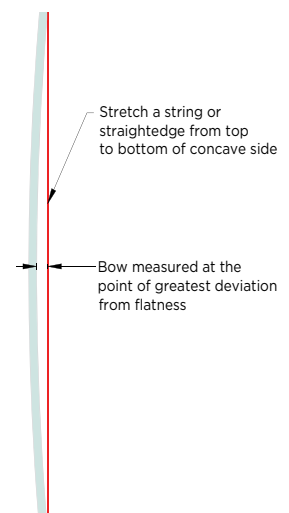

## Glass Inserts

- Glass Inserts are available in 1/2" or 3/8" thicknesses.
- Both 3/8" and 1/2" glass can be specified to any width from 8" to 48" in 1/8" increments.
- 1/2" glass can be specified up to 10' and 3/8" glass can be specified up to 9' in height, in 1/8" increments.
- 3/8" glass is limited to a maximum of 2 consecutive Glass Inserts in a row.
- When specifying 3/8" glass you must order the additional seal, SIVSEAL38GLASS.
- Glass edges are straight (not beveled).
- Glass is available in Clear, Low Iron, Frost or Clear Laminated color options .

**NOTE — COM Glass:** Customers may choose to source COM glass panels locally. To specify Volo Frameless Wall with COM glass, customers must order all components that are not Glass Insert part numbers in the usual manner, and must also order the Glass Hardware Kit (VFGHK, see below). The Volo Frameless Glass Hardware Kit provides all the necessary hardware to support the customer's glass insert.

**NOTE —** Volo Frameless Wall STC acoustic rating is a factor of the Glass Panel thickness. The 1/2" glass has an STC rating of 35 - 36 and 3/8" glass is rated 30 - 31.

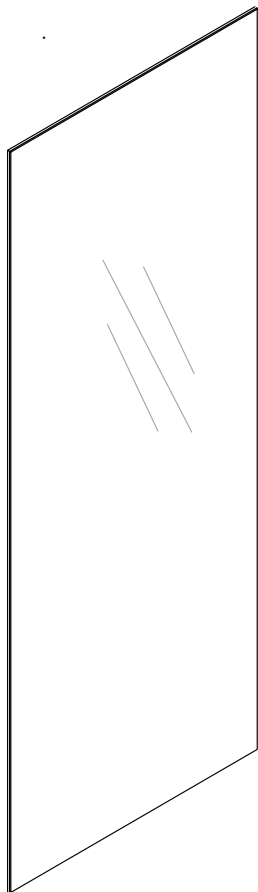

Straight (Flat) Edge Glass, 1/2" or 3/8" thick

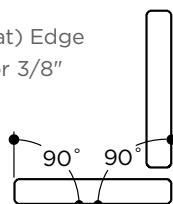

### VFGHK Glass Hardware Kit

Required for COM glass installation, or order as needed for replacement parts.

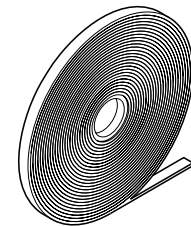
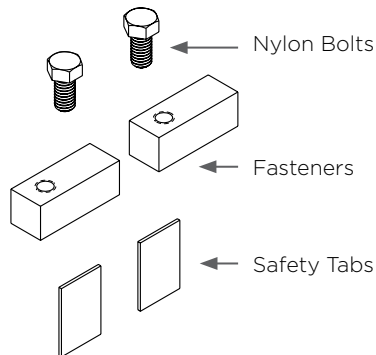

**Joint Filler Tape**  
Fills glass-to-glass panel joint. Order as needed.

When specifying Glass Inserts for a corner butt joint, plan for the front/outside panel to overlap the side panels for a clean, finished appearance.

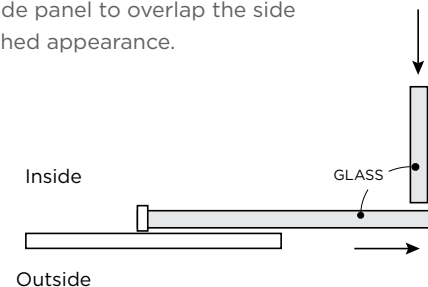
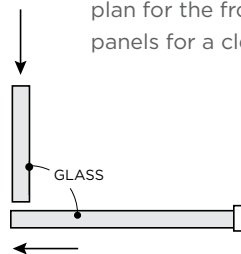

## Framing Elements

- Framing Elements consist of a Ceiling Runner, Floor Runner and Vertical Adapter.
- Floor Runner or Vertical Adapter attaches to drywall.
- Vertical Adapter attaches to a Volo Post or Door Section.
- When attaching to drywall, the optional Foam Tape shipped with the Vertical Adapter must be be applied to create a seal/light block on the building wall. Consider using Floor Runner instead.
- Framing elements ship with 1/2" Glass Seals installed to provide a secure fit for the inserts. When specifying 3/8" glass, you must order the additional Seal model SIVSEAL38GLASS and change out onsite.
- Framing Elements are available in any Standard or Premium trim color finish.

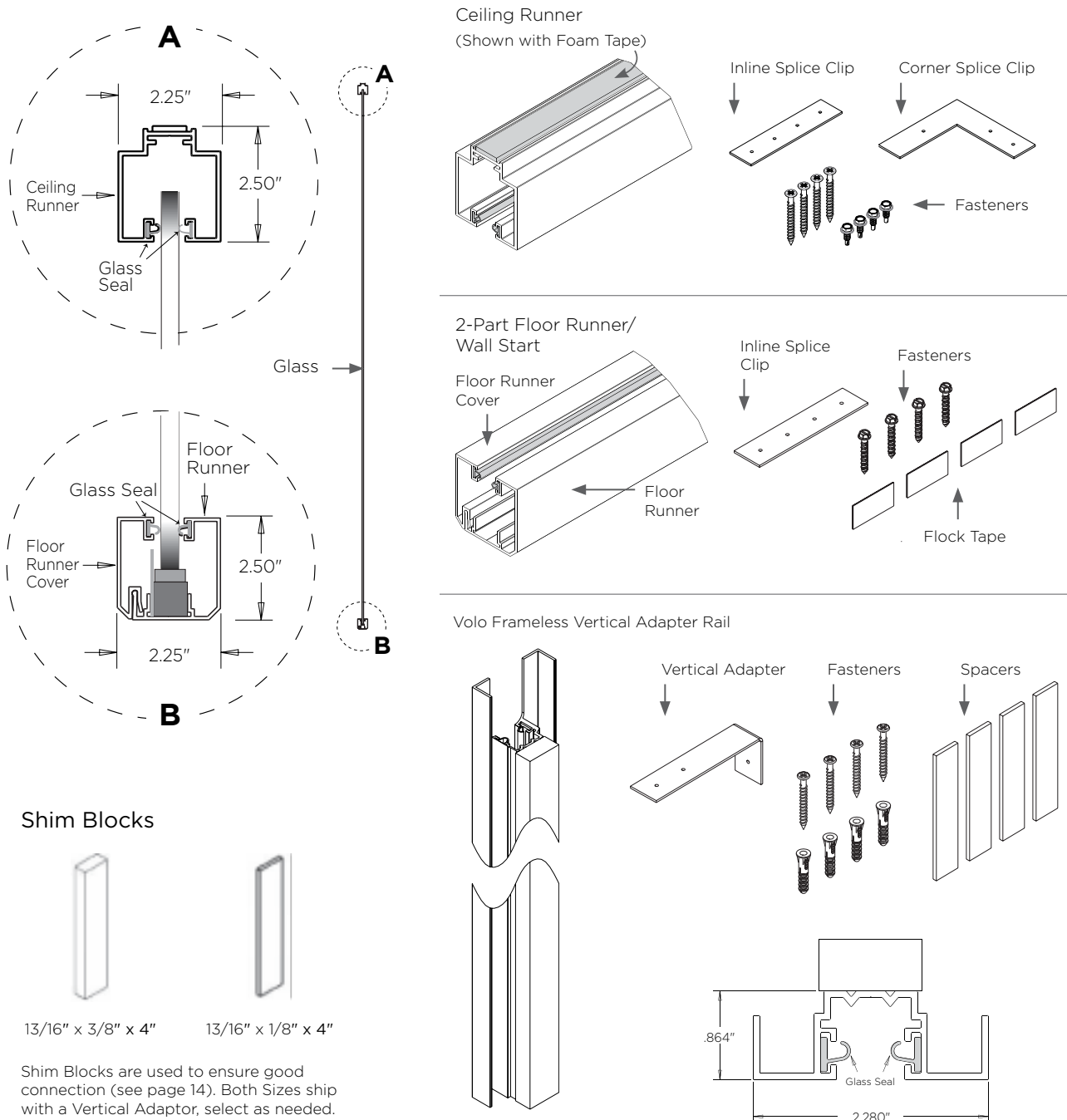

## Layout Standards

### 2-Part Floor Runner/Wall Start as Vertical Adaptor

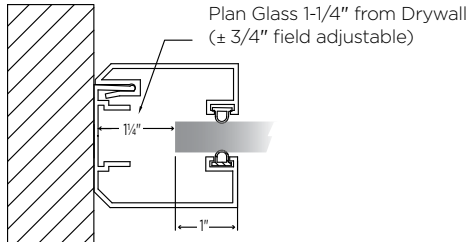

### Vertical Adapter Rail

Used between Volo Frameless and Volo Framed Panels, all conditions. See Conditions information on page 14.

Adjustment Range

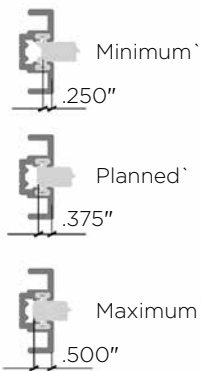

### Door Standards

- 43-3/8" (42" Slider + 1-3/8")
- 49-3/8" (48" Slider + 1-3/8")
- 40-3/8" (39" Swing + 1-3/8")

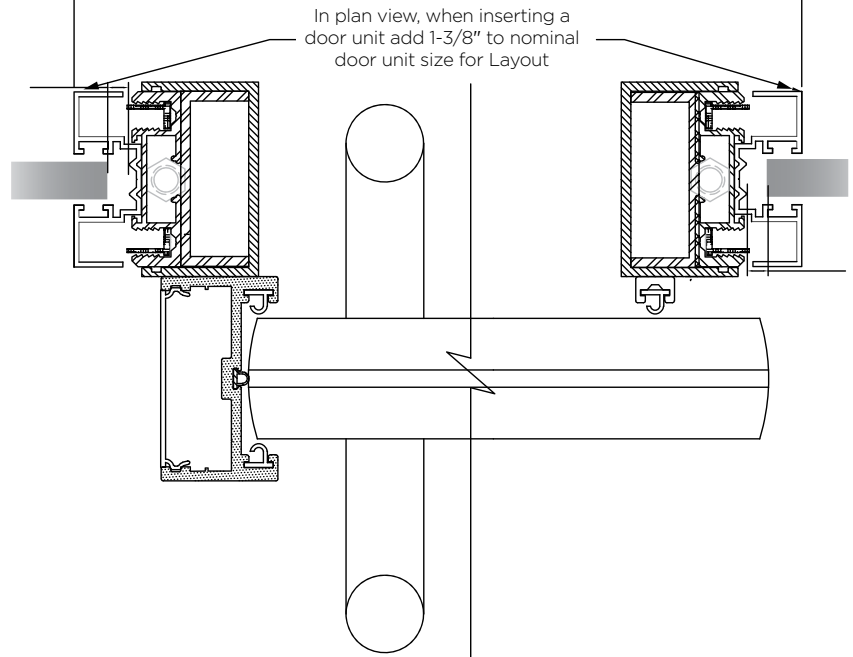

### Single Swing Door

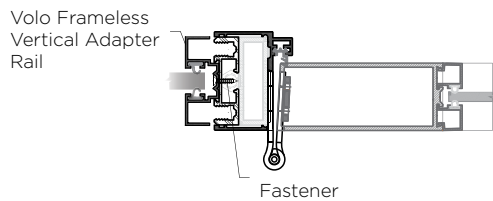

### Double Swing Door

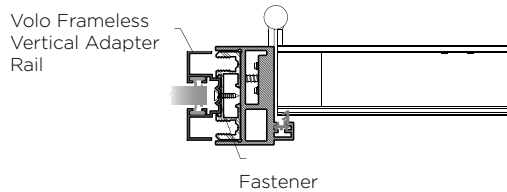

### Sliding Door

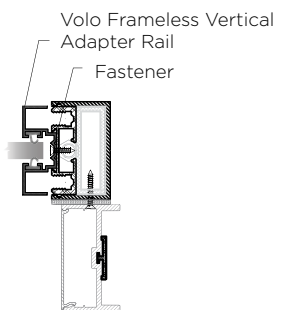

Plan Glass 1/4" out from clip node on any panel or doorframe

## Conditions

### Inline Condition

VCVM2W

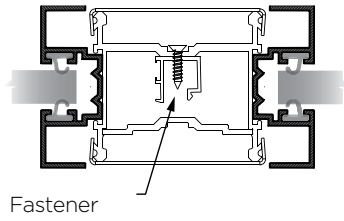

### 3-Way Condition

VCVM3W

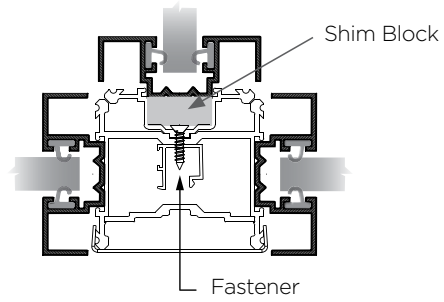

### 90° Condition

VCVM90

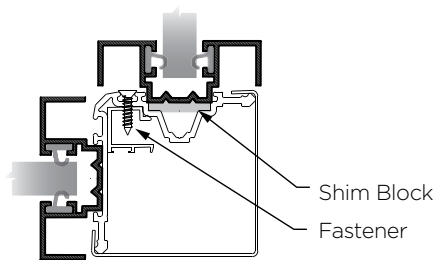

### 4-Way Condition

VCVM4W

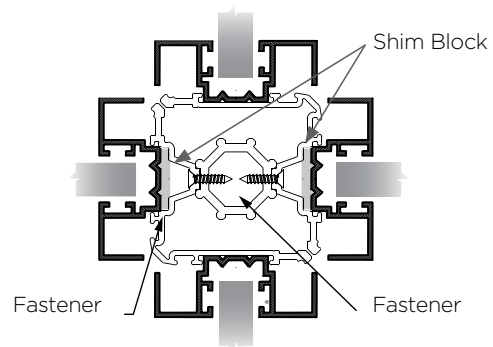

### 3-Way 90° and 135° Condition

VCVM3W90135

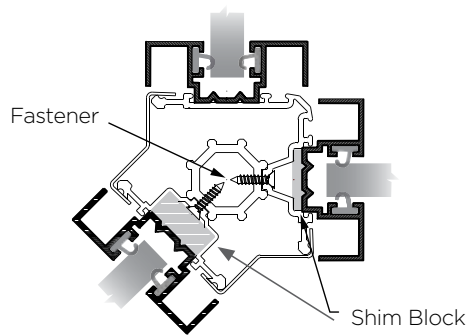

### 2-Way 135° Condition

VCVM2W135

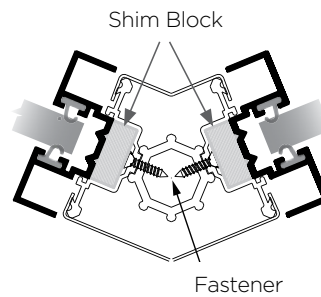



## Crown and Base Styles for Volo Framed Panels

- Since power/data routing and access is determined by Base selections, it's important to select it with this requirement in mind.
- Vinyl Base is offered in 4" and 6" heights. The 4" and 6" Vinyl Base and the Aluminum Base all sit slightly proud of the panel's lower rail. The 6" Vinyl Base is required for horizontal electrical access. 4" and 6" Vinyl Base can be specified in standard Smooth Trendway trim colors, but not in the Satin Etch anodized aluminum color.
- Aluminum Base affords a clean, modern aesthetic. It is 1/8" thick and sits slightly proud of the frame.
- The bottom of the lower tile will align for 4" Vinyl and Aluminum Base Frames.
- The Reveal Crown is lower in height than the Traditional Crown and slightly recessed, for a more subtle transition to the ceiling.
- Different Base configurations can be combined within a layout, with transitions at corner or 3-way conditions. Use this flexibility to enhance power/data routing and access. **Note:** 4" and 6" Vinyl Base requires the use of Base End Caps at end-of-run and visible transition locations.
- **NOTE: When planning for a Volo application that is not attached to a ceiling, the Freestanding Volo Kit contains all the parts needed to effectively provide the structural integrity required for freestanding capability. Order part number VFCK. This method adds the rigidity necessary for a freestanding wall up to a 12' run. If you desire other dimensions, contact your Trendway Architectural Specialist and design team for help. Panels must be securely braced during installation of Volo freestanding applications. Please refer to instruction sheet [INS659](#) for proper installation sequence.**

### Crown Styles

*Shown with Flat style drop ceiling*

REVEAL CROWN



TRADITIONAL CROWN



### Base Styles

ALUMINUM BASE

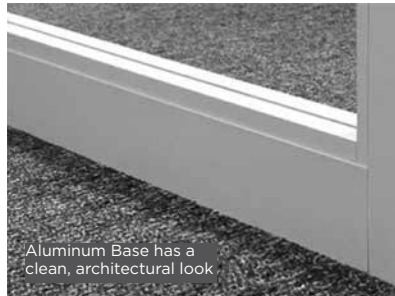

4" VINYL BASE



6" VINYL BASE



# Panel Frames

**Standard Panel Frame** | Frames are constructed of 2-1/4" thick verticals (stiles) and horizontals (rails). Elements consist of extruded anodized aluminum. Standard Frames can accommodate Center Mount Glass, and from one (Monolithic) up to 7 Insert or Outsert Tiles per side. 4" & 6" Base Panels do not include the Floor Runner - it must be ordered separately. NOTE: Aluminum Base option ships with Floor Runner attached.

**WIDTHS:** Standard Frames can be specified from a minimum of 6" to a maximum of 48" in 1/8" increments.

**HEIGHTS:** Standard Panel Frames can be specified from a minimum of 88" to a maximum of 120" total panel height in 1/2" increments.

**THICKNESS:** 2-1/4" (plus 1/4" per side for Outsert Tiles).

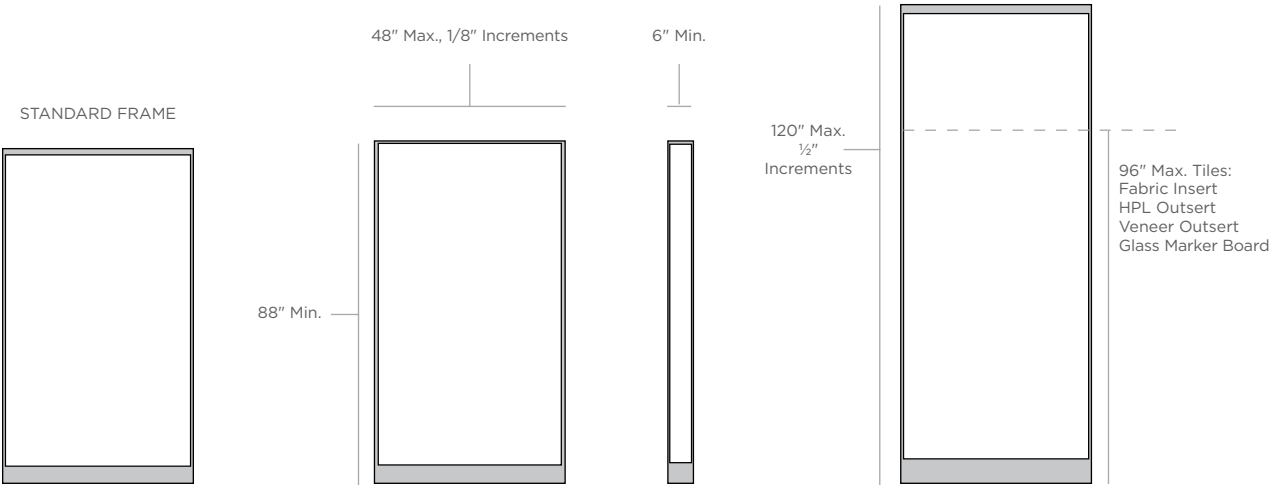

**Door Height Panel Frame** | Door Height frames are similar to standard frames, and are available up to 48" wide (Center Mount Glass Tiles available up to 60") and come complete with a muntin rail installed to align with the elevation detail of a partial-height door. They can be specified to match the available door heights of 7', 8' or 9'. Door Height frames can be further segmented below this initial segment height, but not above.

**WIDTHS:** Door Height Frames can be specified from a minimum of 6" to a maximum of 48" in 1/8" increments, except for Center Mount Glazing Tiles which are available for 48" to 60" width (Door Height Frames only).

**HEIGHTS:** Door Height Frames can be specified from a minimum of 96" to a maximum of 120" in 1/2" increments.

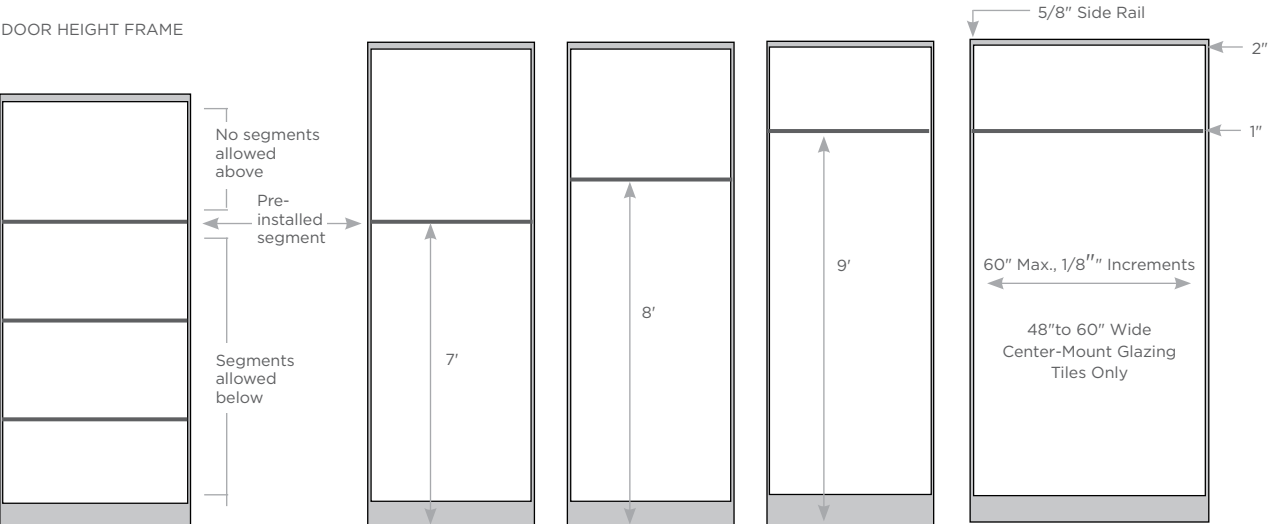

# Volo Doors

**Doors** | Volo Doors are available in Sliding (Frameless Glass, Aluminum Framed, Wood Flush/Solid and Full Lite) and Swing (Aluminum Framed, Wood Flush/Solid and Full Lite) models. All doors must be specified either Right or Left Hand. See the illustration below to determine which to specify. NOTE: All Doors are ADA compliant, with a minimum 32" clear opening (see detailed Dimension, page 16-17). They are available with the same glazing options offered for panel frames, all tempered glass: Clear, Frost, Low Iron or Laminated. (Frost is installed with the matte texture on the inside of the enclosed space. All tempered glass has a visible watermark.)

Doors must be specified Full Height or Partial Height to match the specified Frame or Section.

## SWING DOOR

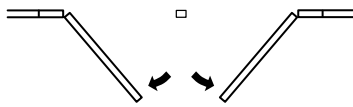

Right-Hand Swing\*

Left-Hand Swing\*

\*Based on Doors swinging out of the room and into the hallway.

## SLIDING DOOR

Right-Hand Slide

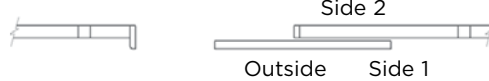

Left-Hand Slide

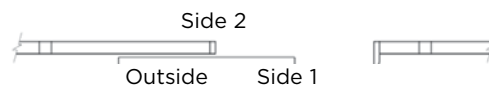

NOTE: **Swing doors** do NOT have a BD (Blank Door) hardware option. (See options below.)

### SINGLE DOOR HARDWARE OPTIONS

- BD and BDL - Blank Door: Allows for COM pulls or locksets. Doors must be machined onsite. BDL includes non-SFIC lock. (Sliding Door only)
- NH - No Hardware: Allows for COM lever sets. Standard door prep identified on Volo Aluminum Framed Swing Door cut sheet.
- LP - Lever Passage set non-locking
- LL - Lever Lock set random key locking (non SFIC)
- LLICWOC - Lever Lock set, SFIC (COM core, not included)

### SINGLE DOOR HARDWARE OPTIONS

- BD and BDL - Blank Door: Allows for COM pulls or locksets. Doors must be machined onsite. BDL includes non-SFIC lock. (Sliding Door only)
- NH - No Hardware: Allows for COM lever sets. Standard door prep identified on Volo Aluminum Framed Swing Door cut sheet.
- LP - Lever Passage set non-locking
- LL - Lever Lock set random key locking (non SFIC)
- LLICWOC - Lever Lock set, SFIC (COM core, not included)

## Sliding Door Sections

---

Sliding Doors are ordered as Sections, which come complete with Door and Frame plus optional Soft Close mechanism and Hardware when specified. Refer to the Cut Sheet for each Sliding Door to find detailed specifications: Volo Frameless Glass Sliding Door, Volo Aluminum Framed Sliding Door, Volo Aluminum Framed Double Sliding Door, Volo Wood Sliding Door, Volo Wood Double Sliding Door.

All door pulls are available in Satin Chrome 626 finish. For Double Sliding Door Post and Ladder Pulls, Black finish is also available as a standard option. Black finish is available as a Service Part for other Door styles. Hardware options include:

- BD and BDL - Blank Door: Allows for COM pulls or locksets. Doors must be drilled/machined on-site. BDL includes lock (non SFIC).
- BDLICWOC - Blank Door Locking SFIC less core
- 18N - 18" Post Pull non locking
- 18L - 18" Post Pull locking (non SFIC)
- 18LICWOC - 18" Post Pull Locking SFIC less core
- 36N - 36" Post Pull non locking
- 36L - 36" Post Pull locking (non SFIC)
- 36LICWOC - 36" Post Pull Locking SFIC less core
- 72N - 72" Ladder Pull non locking
- 72L - 72" (Single Sliding Door) Ladder Pull locking (locks into floor)
- 72L - 72" (Double Sliding Door) Ladder Pull locking SFIC with core - Random Key-Best A Keyway (locks into floor)

**Note:** for Frameless Glass Doors, locking is accomplished with the Patch Lock, which is separate from the Pull.

All doors except Frameless Glass can also be specified BD, BDL or BDLICWOC, the Blank Door option. The BD option allows COM pulls or lock sets. Doors must be drilled/machined on-site as required. The BDL option allows for COM pulls and includes a lock. Doors must be drilled/machined on-site to accommodate COM pull, but door will be bored for our standard mortise lock which is included.

**NOTE:** If the Sliding Door will be positioned over Outsert Tiles when opened, a Sliding Door Outsert Kit must be specified (SIVSDOUTKIT). The Kit includes spacers that will ensure proper clearance between the door and the tiles.

### SOFT CLOSE MECHANISM

The Soft Close ships standard with Frameless Glass Sliding Doors, and is available as an option for all door models.

**NOTE: Do not operate with excessive force.** The Mechanism exerts slight resistance as it begins the soft close operation: do not force. You can release at this point and the action completes gently and automatically.

#### Soft Close Mechanism

SIVSOFTCLOSE

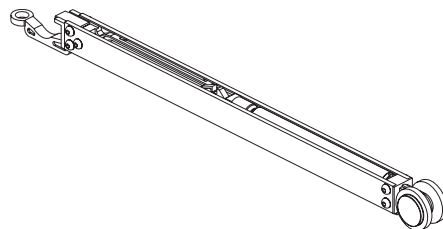

Frameless Glass Sliding Door Section | Frameless Glass Sliding Doors are 1/2" thick glass and are available at **Full Height only. 42" width is available up to 9'. Not available above 9' at this time. 48" width is available at 8' height ONLY.** Doors are specified as either Right or Left opening as viewed from the exterior of the space. Volo Frameless Glass Sliding Door Cut Sheet for detailed dimensions and specifications. Find complete door dimensions on page 17.

Frameless Glass Sliding Doors are available with three tempered glass options: Clear, Frost or Low Iron. (Frost is installed with the matte texture on the outside of the enclosed space. All tempered glass has a visible watermark.)

Two locking options are available, the Patch Lock and Ladder Pull. The Patch Lock (not integral to the Pull), has a stainless steel appearance that is similar to the Satin Chrome 626 finish on the Pulls and lock cylinder. The locking 72" Ladder Pull throws a lock rod into a 1"-deep dustproof strike. See page 22 for lock details.

NOTE: Frameless Glass Doors require a soft close mechanism.

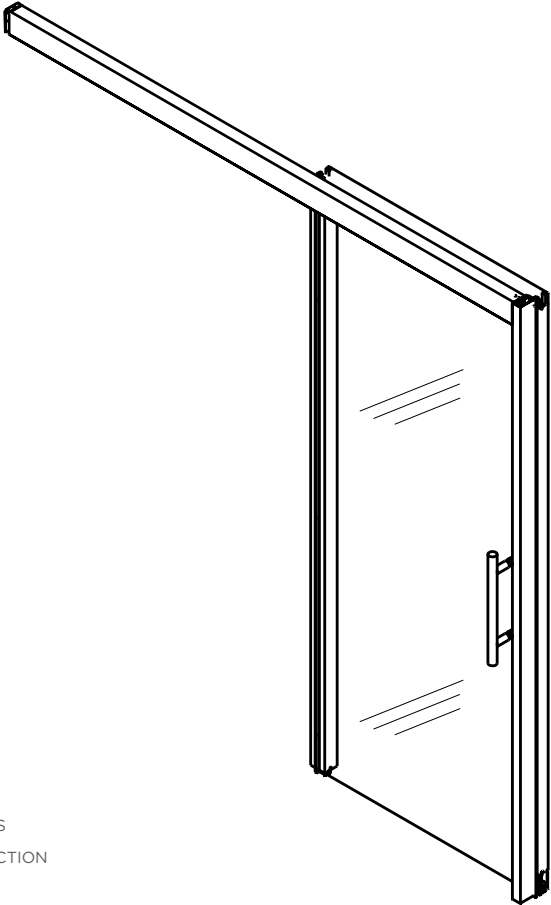

FRAMELESS GLASS  
SLIDING DOOR SECTION

### Aluminum Framed Single Sliding Door Section — Full Height and Partial Height |

Aluminum Framed Sliding Doors are offered in three stile/rail combinations (below). See the [Volo Aluminum Framed Sliding Door Cut Sheet](#) for detailed dimensions and specifications. Partial Height Doors require an upper Tile to be specified for the transom opening. Find complete door dimensions on page 19.

- 2-2-2:** 2" Vertical Stiles and 2" Horizontal Rails
- 2-2-4:** 2" Vertical Stiles and 2" top Horizontal Rail paired with a 4" bottom Horizontal Rail
- 4-4-4:** 4" Vertical Stiles and 4" Horizontal Rails (required for 72" Ladder Pull)

Aluminum Framed Single Sliding Doors are available with the same glazing options offered for panel frames, all 1/4" tempered glass: Clear, Frost, Low Iron and Laminated. (Frost is installed with the matte texture on the outside of the enclosed space. All tempered glass has a visible watermark.)

Doors can also be specified BD or BDL, the Blank Door option. The BD option allows COM pulls or lock sets. Doors must be drilled/machined on-site as required. The BDL option allows for COM pulls and includes a lock. Doors must be drilled/machined on-site to accommodate COM pull, but door will be bored for our standard mortise lock which is included.

NOTE: The ceiling height must be greater than the height of the Partial Height Door by at least 12". If it is less than 12" higher, then a Full Height Door Section must be specified.

The height of a Partial Height Door is specified as either 7' (84"), 8' (96") or 9' (108").

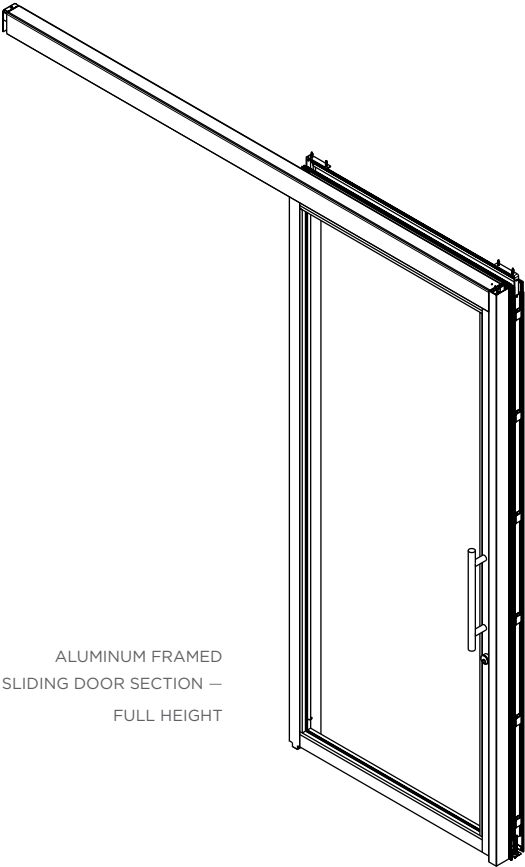

ALUMINUM FRAMED  
SLIDING DOOR SECTION —  
FULL HEIGHT

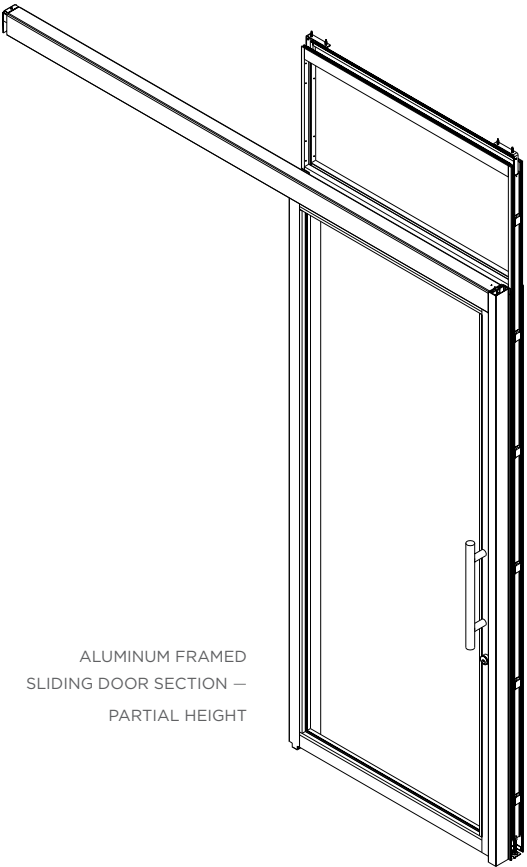

ALUMINUM FRAMED  
SLIDING DOOR SECTION —  
PARTIAL HEIGHT

Ceiling Height  
must be at least  
12" greater than  
a Partial Height  
Door

Aluminum Framed Double Sliding Door Section — Full Height Only | Aluminum Framed Double Sliding Doors are offered in three stile/rail combinations (below). See the [Volo Aluminum Framed Double Sliding Door Cut Sheet](#) for detailed dimensions and specifications. Find complete door dimensions on page 19.

- 2-2-2:** 2" Vertical Stiles and 2" Horizontal Rails
- 2-2-4:** 2" Vertical Stiles and 2" top Horizontal Rail paired with a 4" bottom Horizontal Rail
- 4-4-4:** 4" Vertical Stiles and 4" Horizontal Rails (required for 72" Ladder Pull)

Aluminum Framed Double Sliding Doors are available with the same glazing options offered for panel frames, all 1/4" tempered glass: Clear, Frost, Low Iron and Laminated. (Frost is installed with the matte texture on the outside of the enclosed space. All tempered glass has a visible watermark.)

Doors can also be specified BD or BDL, the Blank Door option. The BD option allows COM pulls or lock sets. Doors must be drilled/machined on-site as required. The BDL option allows for COM pulls and includes a lock. Doors must be drilled/machined on-site to accommodate COM pull, but door will be bored for our standard mortise lock which is included.

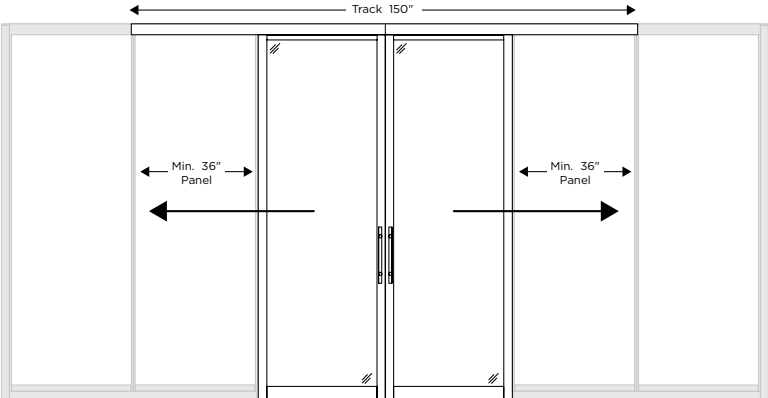
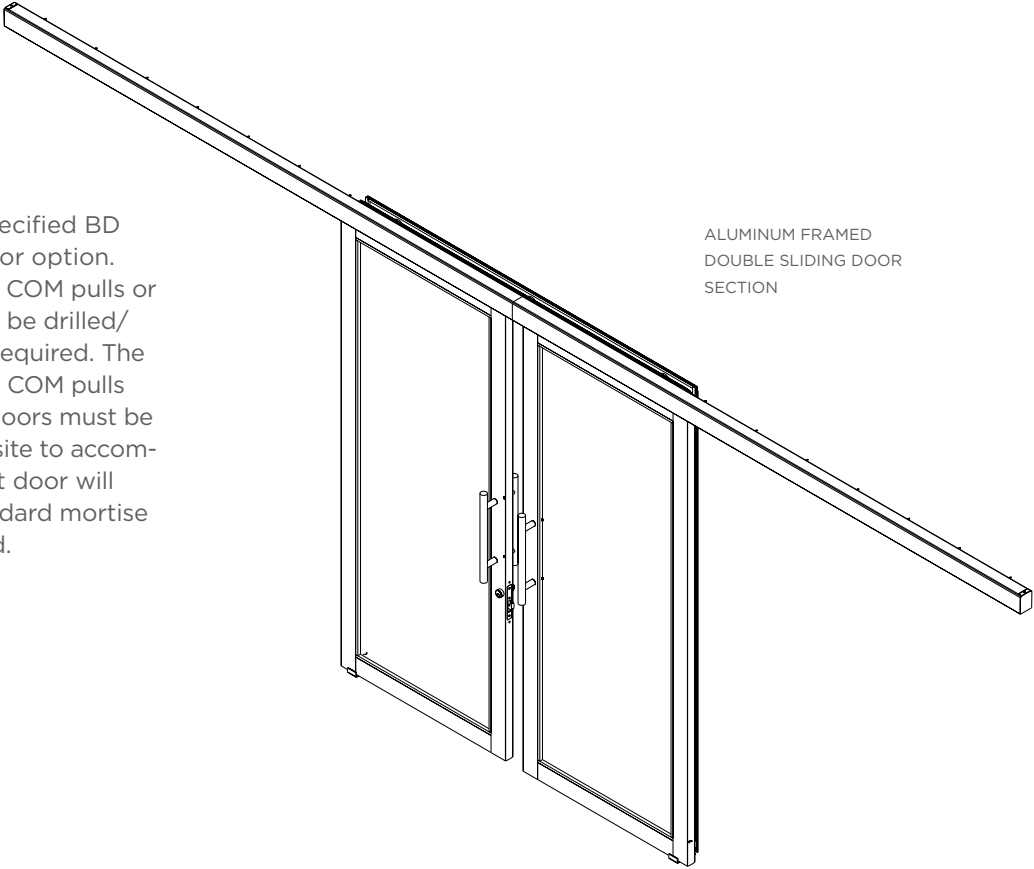

For proper clearance, panels at least 36" wide must be specified to the right and left of the double door.

Wood Single Sliding Door Section — Full Height and Partial Height | Doors offered in two styles, Flush/Solid or Full Lite. They can be specified in HPL or Veneer surface. See the [Volo Wood Sliding Door Cut Sheet](#) for detailed dimensions and specifications. Find complete door dimensions on page 19.

Full Lite Wood Doors are available with the same glazing options offered for panel frames, all tempered glass: Clear, Frost, Low Iron or Laminated. **(Frost is installed with the matte texture on the outside of the enclosed space. All tempered glass has a visible watermark.)**

Doors can also be specified BD or BDL, the Blank Door option. The BD option allows COM pulls or lock sets. Doors must be drilled/machined on-site as required. The BDL option allows for COM pulls and includes a lock. Doors must be drilled/machined onsite to accommodate COM pull, but door will be bored for our standard mortise lock which is included.

NOTE: The ceiling height must be greater than the height of the Partial Height Door by at least 12". If it is less than 12" higher, then a Full Height Door Section must be specified.

The height of a Partial Height Door is specified as either 7' (84"), 8' (96") or 9' (108").

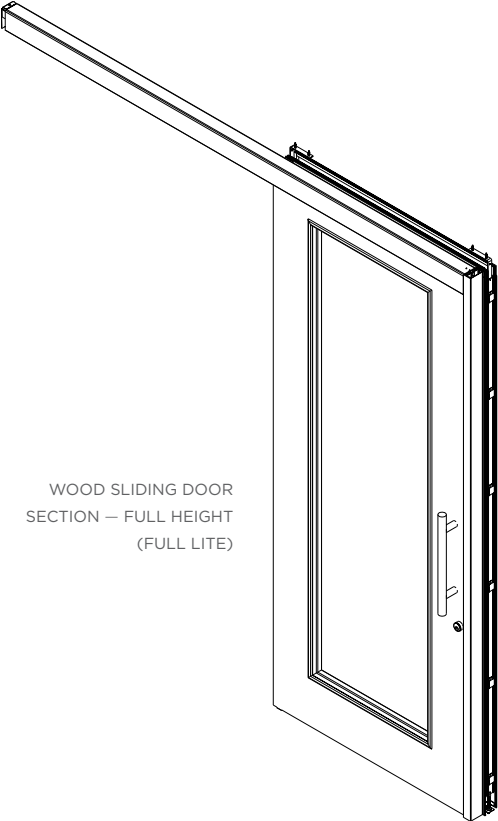

WOOD SLIDING DOOR SECTION — FULL HEIGHT (FULL LITE)

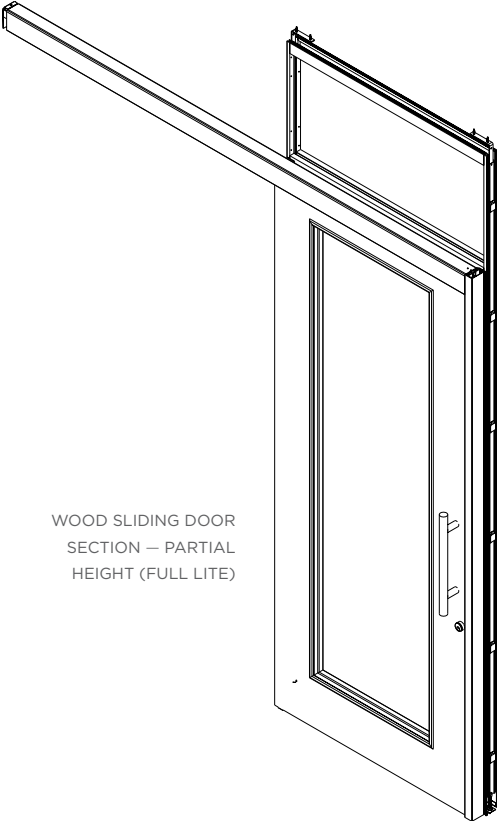

Ceiling Height must be at least 12" greater than a Partial Height Door

WOOD SLIDING DOOR SECTION — PARTIAL HEIGHT (FULL LITE)



Wood Double Sliding Door Section – Full Height Only | Doors offered in two styles, Flush/Solid or Full Lite. They can be specified in HPL or Veneer surface. See the [Volo Wood Double Sliding Door Cut Sheet](#) for detailed dimensions and specifications. Find complete door dimensions on page 19.

Full Lite Wood Doors are available with the same glazing options offered for panel frames, all tempered glass: Clear, Frost, Low Iron or Laminated. **(Frost is installed with the matte texture on the outside of the enclosed space. All tempered glass has a visible watermark.)**

Doors can also be specified BD or BDL, the Blank Door option. The BD option allows COM pulls or lock sets. Doors must be drilled/machined on-site as required. The BDL option allows for COM pulls and includes a lock. Doors must be drilled/machined onsite to accommodate COM pull, but door will be bored for our standard mortise lock which is included.

WOOD FRAMED DOUBLE SLIDING DOOR SECTION

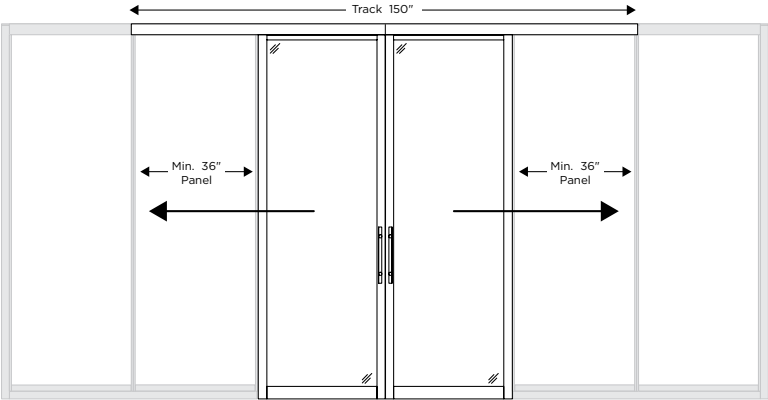
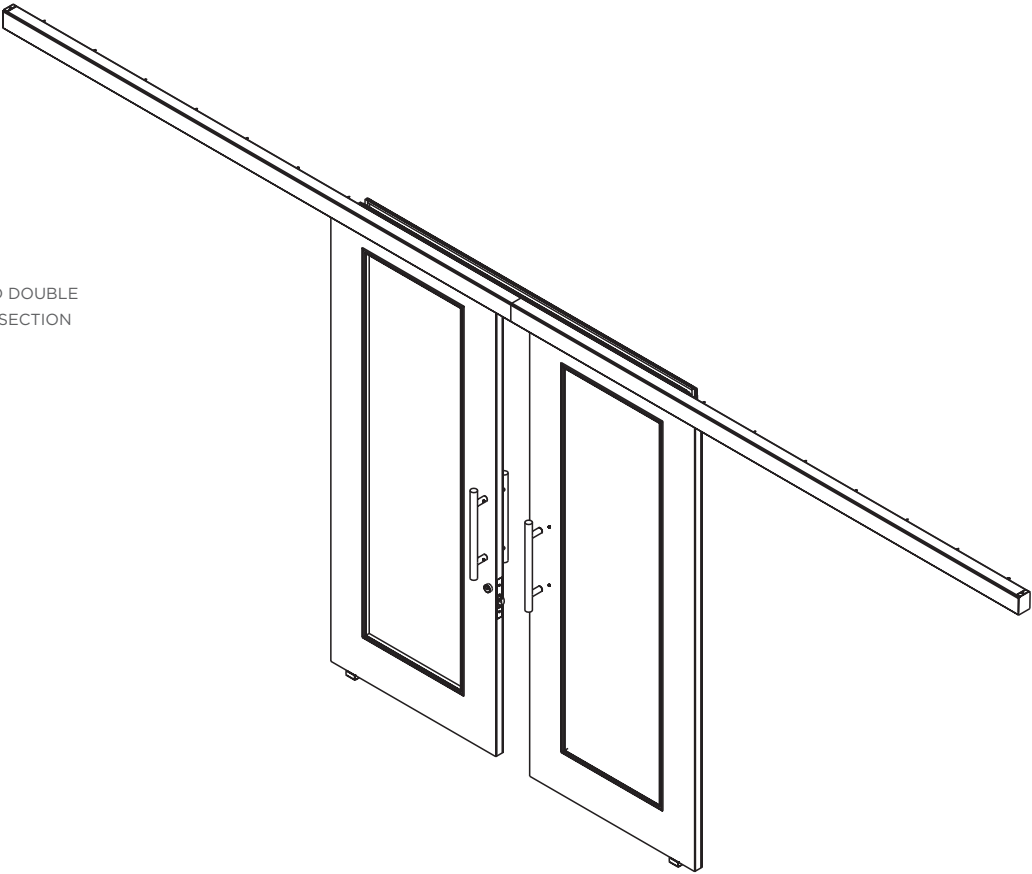

For proper clearance, panels at least 36" wide must be specified to the right and left of the double door.

## Sliding Doors

**Single Frameless Glass Sliding Door** | Frameless Glass Sliding Doors are 1/2" thick and available at Full Height only. The 42" width is available up to 9', and the 48" width is available at 8' height ONLY. The Soft Close option is required for this door.

**Single Aluminum Framed Glass Sliding Doors** | Aluminum Framed Glass Doors are constructed of extruded aluminum. They are 1-3/4" thick and accept 1/4" glazing. Doors can be specified from 88" to 120" high in 1/2" increments. Doors are offered in either Trendway trim paint colors or in an Anodized Aluminum finish.

Aluminum Sliding Door Sections may be specified 2" on all sides (2-2-2), with 2" vertical stiles, 2" top horizontal rail and 4" bottom horizontal rail (2-2-4), or 4" wide on all sides (4-4-4).

Aluminum Swing Door Frames are offered 4" on all sides (4-4-4) or ADA-compliant 4" top and vertical rails with 10" bottom horizontal rail (4-4-10).

**Double Aluminum Framed Glass Sliding Doors** | Double Aluminum Framed Glass Swing Doors are constructed of extruded aluminum. They are 1-3/4" thick and accept 1/4" glazing. Doors can be specified from 83-5/8" to 120" high in 1/2" increments. Doors are offered in either Trendway trim paint colors or in an Anodized Aluminum finish. Actual Door width is 34-1/4", and the clear opening (installed) is 65.5".

Aluminum Framed Swing Doors may be specified 2" on all sides (2-2-2), with 2" vertical stiles, 2" top horizontal rail and 4" bottom horizontal rail (2-2-4), 4" wide on all sides (4-4-4) or ADA-compliant 4" top and vertical rails with 10" bottom horizontal rail (4-4-10).

**Single Wood Sliding Doors** | Wood doors are 1-3/4" thick and accept 1/4" glazing. Wood doors can be specified in either a Flush/Solid or Full Lite style.

Full Lite Wood Sliding Doors have 8" vertical stiles, 4" top horizontal rail and 10" bottom horizontal rail. Full Lite Wood Swing Doors have 6" vertical stiles, 4" top horizontal rail and 9" bottom horizontal rail. They are offered in either High Pressure Laminate (HPL) or Wood Veneer. Doors can be specified from 88" to 120" high in 1/2" increments.

**Double Wood Sliding Doors** | Wood doors are 1-3/4" thick and accept 1/4" glazing. Wood doors can be specified in either a Flush/Solid or Full Lite style.

Full Lite Wood Sliding Doors have 7.625" vertical stiles, 3.75" top horizontal rail and 8.875" bottom horizontal rail. They are offered in either High Pressure Laminate (HPL) or Wood Veneer. Doors can be specified from 84.125" to 107.375" high in 1/2" increments. Actual Door width is 34.25", and the clear opening (installed) is 65.5".

**Note Regarding Sliding Doors:** For conference rooms over 150 s.f. in size or any classroom that holds 10 people or more, swing doors are typically required to meet national access and egress codes.

## Sliding Door Dimensions

Single Sliding Door Style	Door Width (Nominal)	Clear Opening (Nominal/Installed)
Frameless Glass (FH only)	40 <sup>3</sup> / <sub>4</sub> "	34"
Aluminum Framed 42" Door (FH/PH) (2-2-2, 2-2-4)	40 <sup>5</sup> / <sub>8</sub> "	34 <sup>5</sup> / <sub>8</sub> "
Aluminum Framed 42" Door (FH/PH) (4-4-4)	40 <sup>5</sup> / <sub>8</sub> "	34"
Aluminum Framed 48" Door (FH/PH) (2-2-2, 2-2-4)	40 <sup>5</sup> / <sub>8</sub> "	40 <sup>3</sup> / <sub>4</sub> "
Aluminum Framed 48" Door (FH/PH) (4-4-4)	40 <sup>5</sup> / <sub>8</sub> "	40"
Wood Flush/Full Lite 42" Door (FH)	40 <sup>5</sup> / <sub>8</sub> "	34"
Wood Flush/Full Lite 48" Door (FH)	46 <sup>5</sup> / <sub>8</sub> "	40"
Wood Flush/Full Lite 42" Door (PH)	40 <sup>5</sup> / <sub>8</sub> "	35"
Wood Flush/Full Lite 48" Door (PH)	46 <sup>5</sup> / <sub>8</sub> "	41"

### Ceiling Height Determines Door Height

To determine the correct Door height to specify, subtract 3" from the site ceiling height at the exact door location.

**Example:**

Ceiling Ht. = 96" - 3" = 93" **Door Height to specify is 93"**

Double Sliding Door Style	Door Width (individual)	Total Clear Opening (Nominal/Installed)
Aluminum Framed Door (FH only) (2-2-2, 2-2-4)	39"	67"
Aluminum Framed Door (FH only) (4-4-4)	39"	65 <sup>1</sup> / <sub>2</sub> "
Wood Flush/Full Lite Door (FH only)	39"	65 <sup>1</sup> / <sub>2</sub> "
Wood Flush/Full Lite 48" Door (FH)	46 <sup>5</sup> / <sub>8</sub> "	40"

## SINGLE SLIDING DOORS

FRAMELESS GLASS  
SINGLE SLIDING DOORS



Note: the Frost glass option is installed with the matte texture on the inside of the enclosed space. All tempered glass has a visible watermark.

ALUMINUM FRAMED  
SINGLE SLIDING DOORS



2-2-2



2-2-4



4-4-4

WOOD SINGLE  
SLIDING DOORS



Flush/Solid



Full Lite

# DOUBLE SLIDING DOORS

## ALUMINUM FRAMED DOUBLE SLIDING DOOR



Aluminum Framed Double Sliding Doors are available in 2-2-2, 2-2-4 and 4-4-4 styles. Refer to the previous page to view these style options.

## WOOD DOUBLE SLIDING DOORS



Flush/Solid



Full Lite

# Swing Door Frames

## Swing Door Frames

Volo Swing Door Frames are constructed of 2-1/4" thick extruded aluminum vertical and horizontal elements. Swing Door Frames are available in all three base styles.

NOTE: Doors must be specified separately, they are not included with the frame.

WIDTH: Swing Door Frames are available 39" wide only.

HEIGHTS: Swing Door Frames can be specified from a minimum 88" (96" for Partial Height) to a maximum 120" in 1/2" increments.

NOTE: Swing Doors cannot install adjacent to a Reveal Wall Start without a minimum 6" panel between them.

Swing Door Frame — Full Height | Full Height Swing Door Frames require a Full Height Door of identical height and width. The height of the door frame is determined by the ceiling height, and the Door Height is then specified separately to match. There is no transom opening with a Full Height frame. They can be ordered in heights ranging from 88" to 120" in 1/2" increments. The Frame offers up to 1/2" of total height adjustment.

Door Size	Actual Door Width	Clear Opening
36" x 7', 8', 9', 10'	36"	33"

SWING DOOR FRAME - FULL HEIGHT

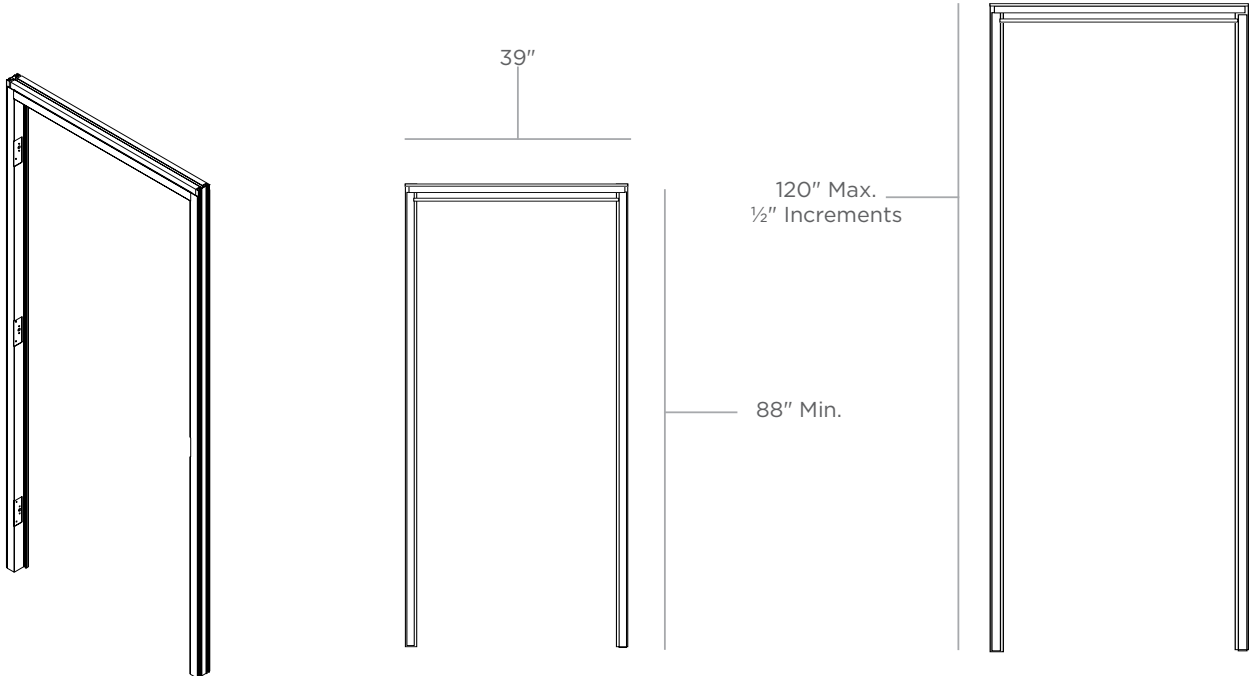

Swing Door Section — Partial Height | There is a transom opening with a Partial Height Sliding Door Frame, with a minimum tile height of 8" — a Volo **upper tile must be specified for this opening**. The Frame offers up to 1/2" of total height adjustment.

Note: If the ceiling height is not higher than a Partial Height Door by at least 12", a Full Height Door Section and Full Height Door must be specified instead.

Door Size	Actual Door Width	Clear Opening
36" x 7'	36"	33"
36" x 8'	36"	33"
36" x 9'	36"	33"

SWING DOOR FRAME - PARTIAL HEIGHT

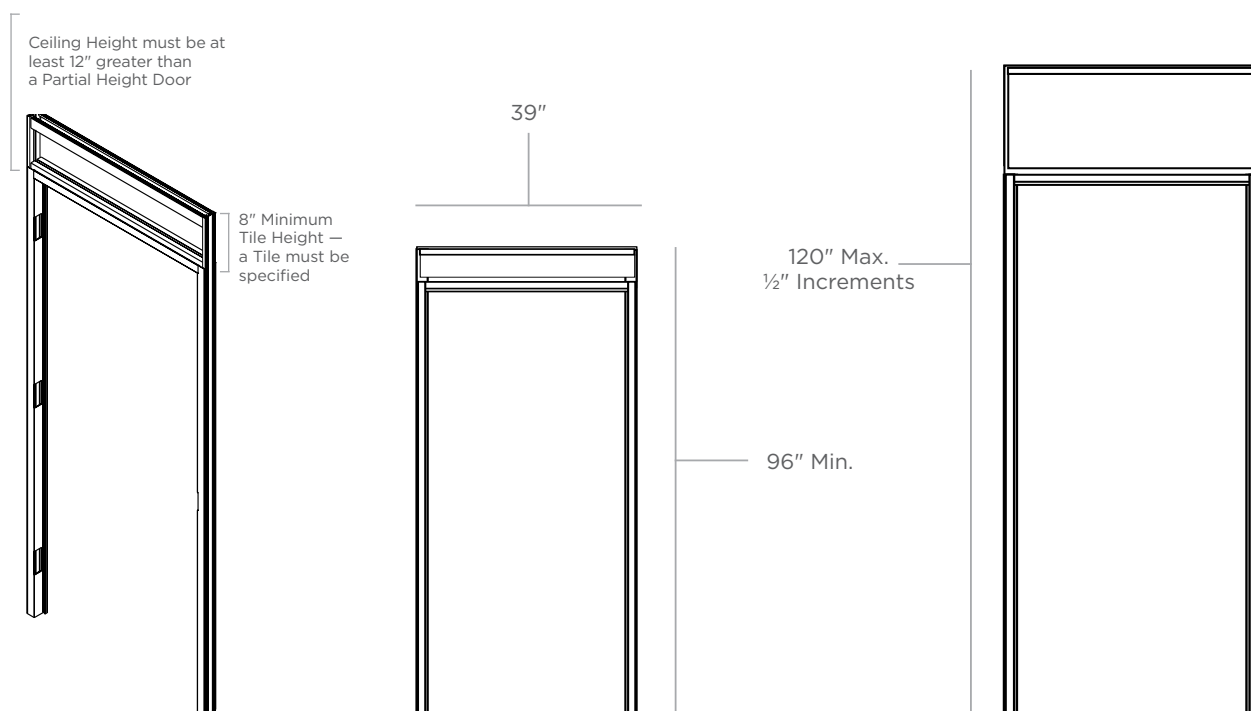

## Swing Doors

**Single Frameless Glass Swing Door** | Frameless Glass Sliding Doors are 1/2" thick and available at Full Height only. The 42" width is available up to 9', and the 48" width is available at 8' height ONLY. The Soft Close option is required for this door.

**Single Aluminum Framed Glass Swing Doors** | Aluminum Framed Glass Doors are constructed of extruded aluminum. They are 1-3/4" thick and accept 1/4" glazing. Doors can be specified from 88" to 120" high in 1/2" increments. Doors are offered in either Trendway trim paint colors or in an Anodized Aluminum finish.

Aluminum Sliding Doors may be specified 2" on all sides (2-2-2), with 2" vertical stiles, 2" top horizontal rail and 4" bottom horizontal rail (2-2-4), or 4" wide on all sides (4-4-4).

**Double Aluminum Framed Glass Swing Doors** | Aluminum Framed Glass Doors are constructed of extruded aluminum. They are 1-3/4" thick and accept 1/4" glazing. Doors can be specified from 88" to 120" high in 1/2" increments. Doors are offered in either Trendway trim paint colors or in an Anodized Aluminum finish.

Aluminum Sliding Door Sections may be specified 2" on all sides (2-2-2), with 2" vertical stiles, 2" top horizontal rail and 4" bottom horizontal rail (2-2-4), or 4" wide on all sides (4-4-4).

Aluminum Swing Door Frames are offered 4" on all sides (4-4-4) or ADA-compliant 4" top and vertical rails with 10" bottom horizontal rail (4-4-10).

**Single Wood Swing Doors** | Wood doors are 1-3/4" thick and accept 1/4" glazing. Wood doors can be specified in either a Flush/Solid or Full Lite style.

Full Lite Wood Sliding Doors have 8" vertical stiles, 4" top horizontal rail and 10" bottom horizontal rail. Full Lite Wood Swing Doors have 6" vertical stiles, 4" top horizontal rail and 9" bottom horizontal rail. They are offered in either High Pressure Laminate (HPL) or Wood Veneer. Doors can be specified from 88" to 120" high in 1/2" increments.

**Double Wood Swing Doors** | Wood doors are 1-3/4" thick and accept 1/4" glazing. Wood doors can be specified in either a Flush/Solid or Full Lite style.

Full Lite Wood Sliding Doors have 8" vertical stiles, 4" top horizontal rail and 10" bottom horizontal rail. Full Lite Wood Swing Doors have 6" vertical stiles, 4" top horizontal rail and 9" bottom horizontal rail. They are offered in either High Pressure Laminate (HPL) or Wood Veneer. Doors can be specified from 88" to 120" high in 1/2" increments.



## Swing Swing Door Dimensions

Single Swing Door Style	Door Width (Actual)	Clear Opening (Nominal/Installed)
Aluminum Framed Door (FH/PH)	35 <sup>3</sup> / <sub>4</sub> "	33"
Wood Flush/Full Lite Door (FH/PH)	35 <sup>3</sup> / <sub>4</sub> "	33"

Double Swing Door Style	Door Width (individual)	Total Clear Opening (Nominal/Installed)
Aluminum Framed Door (FH only)	34 <sup>1</sup> / <sub>4</sub> "	65 <sup>1</sup> / <sub>2</sub> "
Wood Flush/Full Lite Door (FH only)	34 <sup>1</sup> / <sub>4</sub> "	65 <sup>1</sup> / <sub>2</sub> "

# SINGLE SWING DOORS

## ALUMINUM FRAMED SWING DOORS



4-4-4



4-4-10 (ADA)

## WOOD SWING DOORS



Flush/Solid



Full Lite

## DOUBLE SWING DOORS

ALUMINUM FRAMED DOUBLE SWING DOOR



4-4-4 Shown

WOOD FLUSH DOUBLE SWING DOOR



WOOD FULL LITE DOUBLE SWING DOOR



**Door Hardware** | Several architectural-style door hardware options are available. All Door Pull styles are available as Locking and Non-Locking. Locking is available Standard or Small Format Interchangeable Core (SFIC). **NOTE:** Refer to Hardware Cut Sheets for specification details.

SFIC locks are widely used where re-keying is frequent. New cores (COM) can easily be changed out as required. See the FAQ section for details, [page 55](#).

For information about COM hardware accommodation see the FAQ section, page 55,

**SINGLE/DOUBLE SLIDING DOOR PULL OPTIONS**



**18" Post Pull**  
12" centerline-to-centerline of mounting hardware.



**36" Post Pull**  
22.5" centerline-to-centerline of mounting hardware.



**72" Ladder Pull**  
Available for Wood and 4-4-4 Aluminum Framed Doors **only**.



The 72" **Single** Sliding Door Locking Ladder Pull locks into floor with a Schlage "C" keyway. The 72" **Double** Sliding Door Locking Ladder Pull ships with SFIC with core - Random Key-Best A Keyway. Both lock into the floor and throw a lock rod into a 1"-deep dustproof strike (supplied). This option requires floor machining at the job site by a certified installer (above right).

**SINGLE SWING DOOR PULL**



**ADA Lever Set**  
Lever Lockset shown, SFIC lock. Passage Set available.



**SFIC Option**  
(COM Core not included)

**MORTISE LOCK**



Standard Lock shown – SFIC Option available, COM Core, not included

**PATCH LOCK**



Option for Frameless Glass Sliding Door only

**NOTE: Master Key Statement**

Each end user needs their own unique Master Key system. It is most effective for a local locksmith to work with the client on their specific setup, so if changes or additions are required there is a nearby professional who understands their system and can address their future needs. For that reason, supplying master keyed products directly from Trendway is not in the best interest of the end user.

Trendway can provide blank cylinders, without keying, to assist in this process. If frequent changes are anticipated, an interchangeable core system should be used so the cylinder can be removed without disassembling the lock.

## Double Swing Door Hardware

### DOUBLE SWING DOOR PULLS

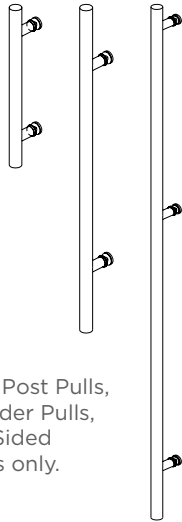

18"/36" Post Pulls,  
72" Ladder Pulls,  
Single-Sided  
versions only.

Push Plates  
included for  
door reverse:  
finish  
defaults to  
specified  
trim color

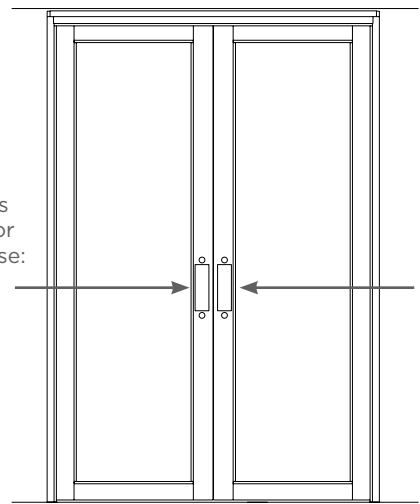

Roller Catch (standard  
when not ordering Door  
Closer or Magnetic Lock)



Inswinging Doors standard:  
hinges match pull finish



Flush Bolt locks into  
floor when Lock option  
is specified



Deadbolt Lock feature  
when not ordering  
Magnetic Lock



Optional Concealed  
Closers on each Door



Single Clear Seal between  
Doors for enhanced  
appearance and function



Optional Magnetic Locks - with and without sensor  
options both pictured above



# Volo Tiles

---

Volo offers three basic Tile styles:

**Insert Tiles** | Insert Tiles sit flush to the frame and leave the entire aluminum frame elements exposed. Tiles are offered for Panel widths from 6" to 48" in 1/8" increments and heights from 8" to 114" in 1/2" increments (Fabric Tiles to 96" only).

**Outsert Tiles** | Outsert Tiles sit 1/4" proud of the frame and leave a 1/4" reveal of frame exposed between tiles. They consist of Upper and Lower Tiles. Tiles are offered for Panel widths from 6" to 48" in 1/8" increments and heights from 8" to 96" in 1/2" increments,

Lower Outsert Tiles are required for the lowest tile position, where a tile installs on the base frame. They must be specified for this position to allow the full range of height adjustment for the panel. Every panel will have at least one Lower Tile, and monolithic Tiles are always Lower Tiles.

Upper Outsert Tiles are required for tile positions other than the lowest position where a tile installs on the base frame.

Back-Painted Outsert Tiles ship separately and are installed onsite. See note on page 24.

**NOTE:** If the Outsert Tiles will be positioned behind a Sliding Door when it is open, a Sliding Door Outsert Kit must be specified (SIVSDOUTKIT). The Kit includes spacers to ensure proper clearance between the door and tiles.

**Center Mount Glazing Tiles** | Center Mount Glazing Tiles provide transparency or translucency anywhere on a Volo panel. Glazing Tiles are Class A fire rated when specified with tempered glass. Center Mount Glazing Tiles are available in widths up to 48" (60" for Door Height Panels only), and in heights up to 114".

**Note:** Frost glass option is installed with the matte texture on the outside of the enclosed space. All tempered glass has a visible watermark. **Note:** 3form is only available in a maximum width of 48" and height of 74-1/4".



Insert Tiles expose the entire aluminum frame



Outsert Tiles reveal 1/4" of frame and sit 1/4" proud of it



Center Mount Glazing Tiles

# Volo Tiles

---

Volo Tiles are available in a wide range of functional and surface material options.

- Vinyl (Insert only)
- HPL (High Pressure Laminate - see Note below)
- Veneer
- Tackable/Fabric (Insert only, maximum 96" height)
- 1/4" Center Mount Glazing — standard options Clear Tempered, Clear Laminated, Frost, Low Iron and 3form. (Frost is installed with the matte texture on the outside of the enclosed space. All tempered glass has a visible watermark.)
- Back Painted Glass Marker Board (Outsert style only - Tiles ship separately crated and are installed to the Panel onsite.)
- Back Painted Glass Marker Board - Steel Backed (enables use of strong magnets for attachment of items — Outsert style only)



Tackable Fabric, HPL Laminate



Veneer



Vinyl

## NOTE:

- **Outsert Tiles** have a maximum height of 96". Lower Outsert Tiles must be specified for the lowest tile position on a frame, where the tile installs on the base frame. This allows the full range of panel height adjustment. Upper Outsert Tiles are specified for all tile positions above the Lower Outsert Tile.

For Outsert Tiles, if the chosen HPL does not have a matching Trendway edge band, the edge defaults to Charcoal. The Charcoal edge is largely invisible in the shadow of the reveal, but the 1/4" edge will be visible at the end of the run.

**NOTE:** Laminates with standard matching edge will be constructed with the matching material. Tiles specified in all other laminate colors are constructed with Charcoal edge. Edge is minimally visible in the reveal.

- **Tackable Fabric Insert Tiles** have a maximum height of 96".
- **Vinyl, Laminate, Veneer and Center Mounted Glazing Insert Tiles** are available in heights up to 114".
- **Laminate Tiles** can be specified in any HPL color in the Trendway offering. For Outsert Tiles see note about matching edge above.
- The grain of Wood Grain HPL and Veneer runs vertically. Grain is not matched from tile to tile.
- **Back Painted Glass Tiles** are available in a selection of 3 standard colors. They can also be custom matched to the customer's choice of Pantone colors. A \$250 matching fee is required and extended lead times apply see the Volo Price List for details. **NOTE: Tiles ship separately crated and are installed to the Panel onsite.**



Center Mount Glazing, Back Painted Glass Outserts

# Volo Tiles

---

## Component Mounting

- Volo Vinyl, HPL & Veneer surfaced Insert and Outsert Tiles will accommodate direct component mounting.
- Components attach with a standard screw and bracket supplied by the installer. The brackets should have a screw at least every 8", a minimum of 4 per bracket.
- Passes ANSI/BIFMA X5.6, can accommodate loads up to 150 lb., or 50 lb. per linear foot including the unit itself. NOTE: There are no run length restrictions for panels attached to the ceiling. Some restrictions apply to Freestanding applications. Contact your Trendway Architectural Product Specialist for details.
- If the unit is later removed, simply replace the tiles.
- Not applicable to Glass or Tackable Tiles.





# Horizontal Connectors

Horizontal Connectors are the system framing elements that connect the panels to the ceiling and floors.

**Ceiling Crown** | Ceiling Crown is available in two styles - Traditional and Reveal. Comes in 12' lengths. (See notes about Ceiling Grid Blocks on page 6.) Freestanding applications require the Freestanding Volo Kit; see specification details on page 11.

**Base Trim** | Vinyl Base is available in 12' lengths, Aluminum Base in 9' lengths so order accordingly (one length per panel). Specify Base to match the frame style. The 6" Traditional Base allows for baseway power and data access. 90° Corner Base is included for a clean, finished appearance for 90° and End-of-Run conditions. End Caps provide a finished appearance on the 4" and 6" Vinyl Base in an end-of-run condition. They are included when End of Run Connectors and Door Frames are ordered for 4" and 6" Vinyl Base. **The 6" End Cap is handed and should be ordered for every outside corner condition.**

**Floor Runner** | Floor Runner needs to be ordered when specifying 4" and 6" Vinyl Base Frames. For the Aluminum Base Frame, Floor Runner ships attached to the frame and does not need to be ordered separately.



FLOOR RUNNER for ALUMINUM BASE (Included – ships attached)

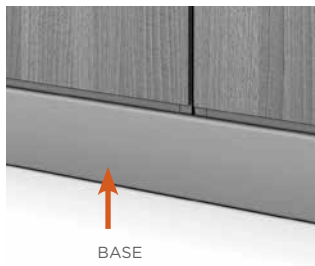
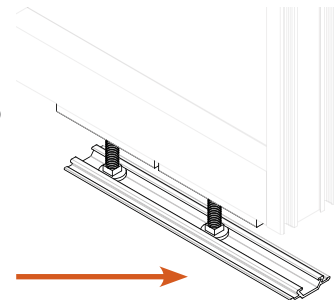

FLOOR RUNNER for 4" and 6" VINYL BASE (Specified and shipped separately)

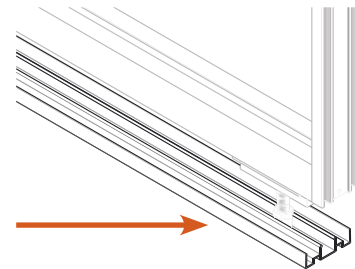

VINYL BASE END CAP FOR END-OF-RUN CONDITIONS (4" and 6" Vinyl Base only)

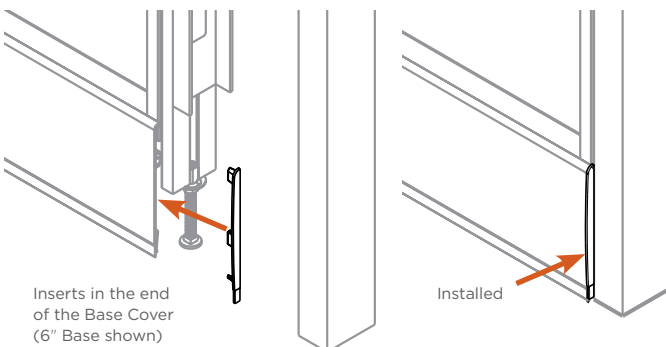

VINYL BASE CORNER BASE COVER FOR 90° CONDITIONS (4" and 6" Vinyl Base only)

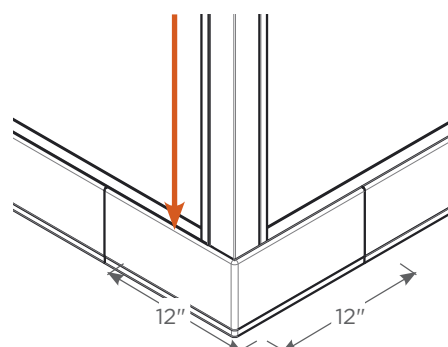

# Horizontal Connectors

## Panel Extenders

A Panel Extender allows the height of a panel to extend by 1" at the Base or Crown. Supplied in 12' lengths. This is a field applied part. Cut the Panel Extender to the exact width measurement of the panel it will be applied to. Apply to the Frame as shown right, using a minimum of 4 screws. Apply top or bottom for 4" and 6" Vinyl Base, top only for the Aluminum Base.

PANEL EXTENDER  
(Can mount to bottom or top of panel)

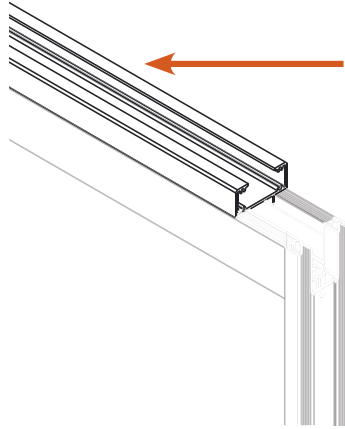

PANEL EXTENDER part # 395796  
(Profile View)

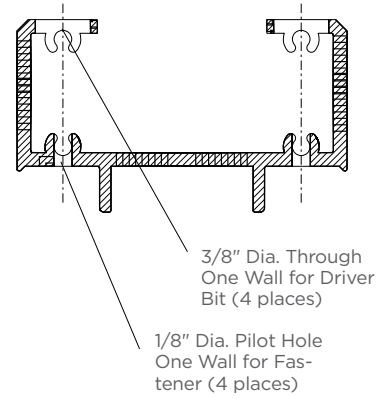

## Volo Panel with Traditional Crown

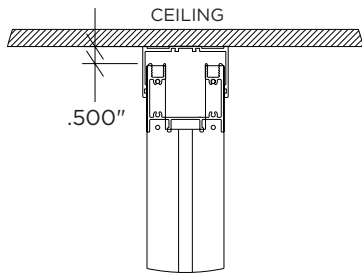

PANEL AS SPECIFIED

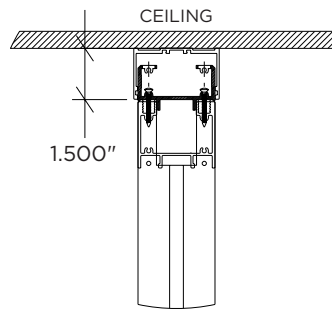

PANEL AS SPECIFIED WITH ONE PANEL EXTENDER

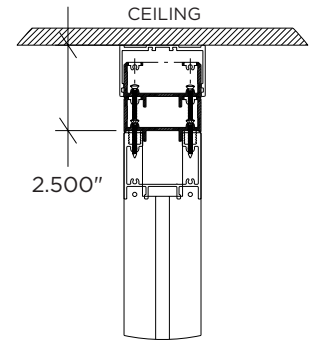

PANEL AS SPECIFIED WITH TWO PANEL EXTENDERS

## Volo Panel with Reveal Crown

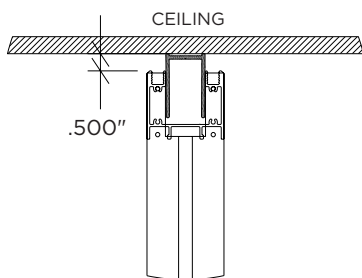

PANEL AS SPECIFIED

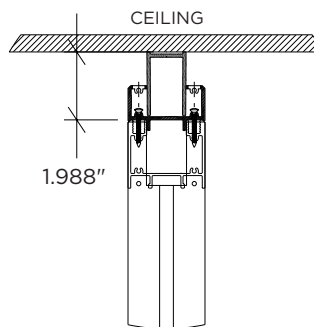

PANEL AS SPECIFIED WITH ONE PANEL EXTENDER

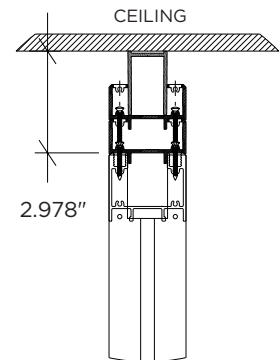

PANEL AS SPECIFIED WITH TWO PANEL EXTENDERS

# Vertical Connectors

Volo Vertical Connectors are the elements that finish Volo panel runs, join them to existing building walls or join two or more Panels. Typical conditions are Wall Starts, In-Line, 3-Way, 4-Way, Corner and End of Run. All Connectors except Reveal Wall Starts are made from the highest grade extruded aluminum and can be specified in all Trendway trim paint colors or in an Anodized Aluminum finish.

**Wall Starts** | Wall Starts create a clean finished connection with an existing building wall.

- Adjustable Wall Starts offer +/- 1/2" of adjustability. They match frame elements and provide flexibility to cleanly attach to wall conditions. If conditions require, additional adjustment range can be achieved by removal of Wall Start Part B (see image below) and/or addition of Filler Connectors (page 31).

**Note: Select the "W" Wood Block option when specifying an Adjustable Wall Start that will attach to a Swing Door section.** This is the only condition where it is required. The Blocks are inserted between the two rail parts to provide added stability.

*Continued, next page*



ADJUSTABLE WALL START

ADJUSTABLE WALL START (Plan View)

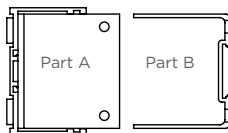

ADJUSTABLE WALL START ADJUSTMENT RANGE

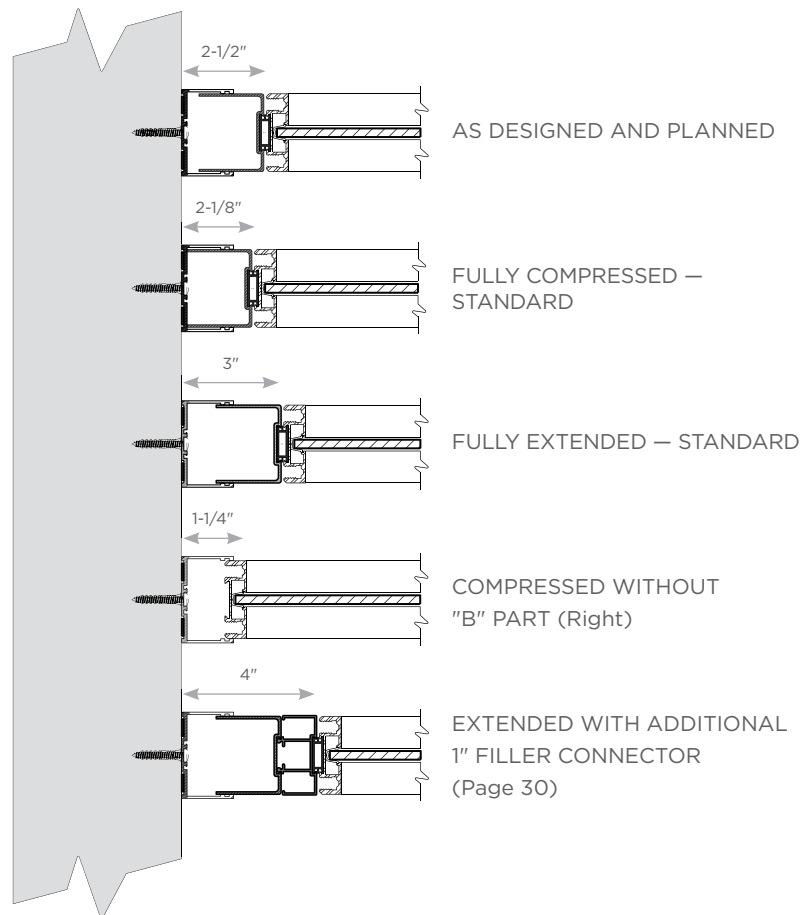

Wall Starts, Continued

- **Reveal Wall Starts** create a subtle, recessed wall connection where minimal (+/- 1/4") adjustability is required. Use in conjunction with an Adjustable Wall start in the run for more flexibility. They are a good choice for transition when connecting with other Architectural Wall products. Available in Charcoal and Shadow Silver colors only. **Not for use directly adjacent to doors or in freestanding applications.**
- **Angled Wall Start Wood Blocks (VCASB10)** can be specified in a range of degrees of angle to accommodate attachment to a wide variety of fixed site wall conditions. They are considered an extension of the architecture, not part of the wall system. Specify any angle between 3 degrees and 87 degrees. Detailed drawing must be submitted with the order. Available in standard Smooth paint finish colors. Wood Blocks (**WB10**) can also be specified to be cut onsite when precise wall angle measurements are not available when the order is placed.
- For irregular site wall conditions, use a solid monolithic Vinyl or Laminate insert panel. Order the panel wide enough to reach the site wall or window glass. Order Traditional Crown for wall connection. Cut on-site as required.



REVEAL WALL START

REVEAL WALL START (Plan View)



Cannot be used in freestanding applications



ANGLED WALL START WOOD BLOCKS CAN BE SPECIFIED TO ACCOMMODATE SITE WALL ANGLES OF BETWEEN 3 AND 87 DEGREES (Curved Wall Pictured Above)

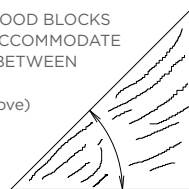

Wood Block (Plan View)



MONOLITHIC INSERT PANELS WITH VINYL OR HPL SURFACES CAN BE CUT ON-SITE TO ACCOMMODATE IRREGULAR WALL CONDITIONS, USING TRADITIONAL CROWN FOR TRIM AROUND THE CUT EDGES

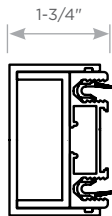

END OF RUN (Plan View)

**End of Run Connectors** | End of Runs are used to create a finished panel when it does not join another panel or an existing building element.

## Inline Connectors

**Inline Electrical Connectors** include covers for optional electrical punch-outs or open duplex boxes to accommodate hard wire power and data. Switches and Power elements must be provided and installed onsite by an electrician. They can be utilized as powered or non-powered. **Modular power may not be utilized in vertical Inline Connectors; power must be hard-wired onsite by a qualified electrician.**

**Inline Angle Condition Wood Block Connectors** are used to attach panels together at a range of angles other than 90 degrees, specified from 3 degrees to 87 degrees. They maintain 1.75" center-of-clip to center-of-wood-block dimension for layout planning purposes. They ship with two Stiles cut to size and attached to the Wood Block, and with 10 panel-to-panel connectors. Specify ceiling height in 1/2" increments.

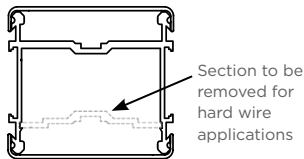

2-WAY INLINE CONNECTOR  
(Plan View)

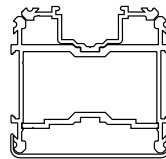

3-WAY INLINE CONNECTOR  
(Plan View)

INLINE ANGLE CONDI-  
TION WOOD BLOCK  
CONNECTOR



**NOTE:** 2-Way Inline Connectors can only accommodate a high-voltage box to be installed on one side of the post. The other side can still accommodate low-voltage (phone/data) cables.

The punch-out dimension is 2.7" x 1.38". Punch-out heights available are:

- 6" - Data Height
- 18" - Standard Height Power (ADA compliant)
- 32" - Work Height Power
- 45" - Switch Height
- 72" - AV Height

**NOTE:** Punch-out locations cannot be back-to-back on both sides of the connector.

Punch-out Description:

- COB 45" Switch Height with Box
- C2AB 18" Standard Height with Box
- C3B 32" Work Height with Box
- C4B 6" Data Height with Box
- C5AB 18" Standard and 32" Work Height with Boxes
- C6AB 18" Standard and 6" Data Height with Boxes
- C7B 32" Work Height and 6" Data with Boxes
- C8B Special Punch Out location with Box
- AVB 72" AV Height
- AVC5AB 72" AV, 18" Standard and 32" Work Height with Boxes
- AVC6AB 72" AV, 18" Standard and 6" Data Height with Boxes



INLINE CONNECTORS OFFER VERTICAL ACCESS TO POWER/DATA. POWER MUST BE HARD-WIRED ONSITE BY A QUALIFIED ELECTRICIAN.

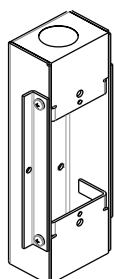

**Vertical Power Routing** | For power to be routed vertically, **hard wiring in the field required.** The Hard wire Box (VVEB) is a custom size and comes with 2 mounting brackets. UL listed. Engineered to fit Volo. Dimensions are 2" x 1-1/3" x 6-1/2".

ELECTRICAL HARD WIRE BOX  
VVEB

## Condition Connectors

**90° Corner Connectors** | Corner Connectors vertically connect panels in 90° corner conditions. A 90° Corner Connector includes a Vertical Cover.

Note; A Corner Base is included when a 4" or 6" Vinyl Base height options is specified. Other base options do not utilize a corner.

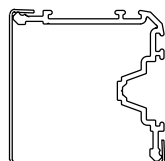

90° CORNER CONNECTOR  
(Plan View)

**2, 3 and 4 Way Connectors** | Vertically connect panels in 3-way, 4-way and 135° 2-way conditions.

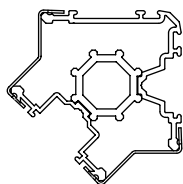

3-WAY PANEL CONNECTOR 90°/135°  
(Plan View)

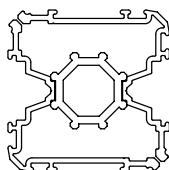

4-WAY PANEL CONNECTOR  
(Plan View)

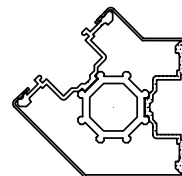

2-WAY 135° PANEL CONNECTOR  
(Plan View)

**Filler Connectors** | 1" and 1/2" Filler Connectors provide the flexibility to add incremental width to a panel run to respond to field requirements. They are inserted in conjunction with other Vertical Connectors. They are best placed at the end of a run next to a Wall Start Connector. Filler Connectors can be inserted "stacked" on top of each other in any combination, for more added incremental width.



1/2" FILLER CONNECTOR  
(Plan View)

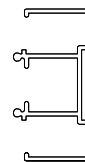

1" FILLER CONNECTOR  
(Plan View)

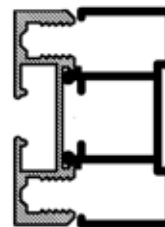

## Power and Data

It's important to establish an understanding of the customer's estimated power and data requirements early in the design process. For an installation where there is a substantial need for power and data access, the 6" Vinyl Base is required. Aluminum and 4" Vinyl Base models can accommodate power only within 2- and 3-way Vertical Connectors, which will require individual hard wired infeed from building power.

### Modular Power | 8 Wire System

The Volo modular electrical system provides many pathways for accessing building electrical power and supplying it where and when it's needed. Power feeds, Power Blocks, power jumpers and duplexes all work together to supply power in the 6" Traditional Base. Power in the Vertical Inline Connectors can be hard wired onsite by a qualified electrician — Punch outs and Boxes are supplied by Trendway (see Vertical Power Routing, next page). This lay in capability makes electrical installation and relocations a snap.

Volo's 8 wire 4-2-2 modular power system is identical in most respects to that of the rest of the Trendway family power components.

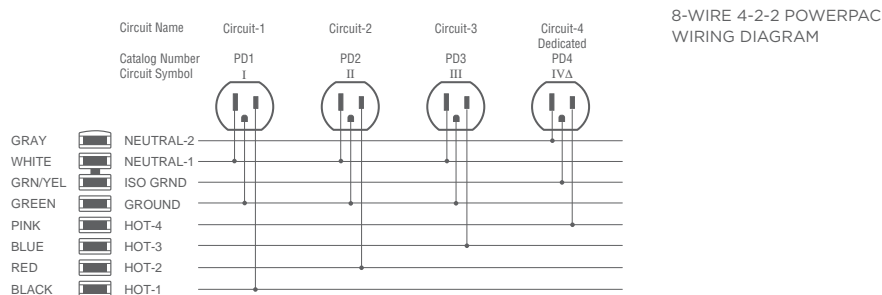

### Accessing Building Power | Ceiling and Base

#### CEILING FEED

The Ceiling Feed connects a building's electrical supply from a ceiling access to the base electrical system. It distributes up to four 20 amp circuits and attaches directly to a Power Block at any one of the four distribution connections. UL Listed and CSA certified.

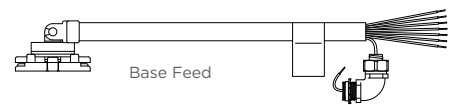
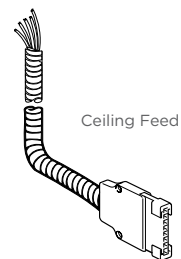

#### END MOUNT BASE FEED (6" Vinyl Base Only)

The End Mount Base Feed is designed to bring building electrical to the Volo electrical system. **The modular end of the Base Feed occupies one duplex location on a Power Block. Use of the End Mount Base Feed reduces duplex capacity by one.** For use with the 6" Vinyl Base only.

### Vertical Data Routing | Data cables (Cat. 5) can be routed vertically in the Vertical Connectors.

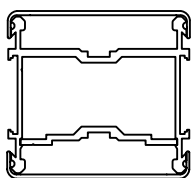

2-WAY INLINE CONNECTOR  
Outside Maximum: 8  
Core Maximum: 20  
Outside Maximum: 8

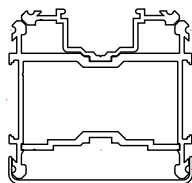

3-WAY INLINE CONNECTOR  
Core Maximum: 20  
Outside Maximum: 8

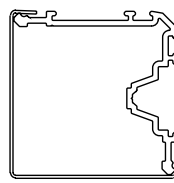

90° CORNER CONNECTOR  
36 Maximum

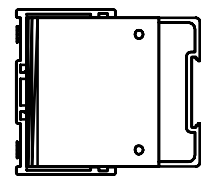

ADJUSTABLE WALL START  
Minimum 40, Maximum 56

Horizontal Power/Data Routing | Cable Capacity and Power Distribution Data can be routed horizontally at the base in all base styles. 6" Vinyl Base panels offer the greatest cable capacity.

ALUMINUM BASE

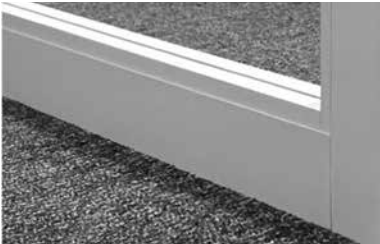

Cable Capacity: 40 Cat. 5/5E or 32 Cat. 6 Cables

4" VINYL BASE



Cable Capacity: 40 Cat. 5/5E or 32 Cat. 6 Cables

6" VINYL BASE WITHOUT OUTLETS



Cable Capacity: 104 Cat. 5/5E or 80 Cat. 6 Cables

6" VINYL BASE WITH OUTLETS



Cable Capacity:  
 Receptacle one side = 43 Cat. 6 Cables  
 Receptacles both sides = 38 Cat. 6 Cables

Horizontal Cable Capacity for 6" Vinyl Base

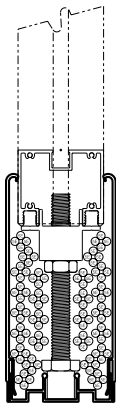

104 Cat. 5/5E

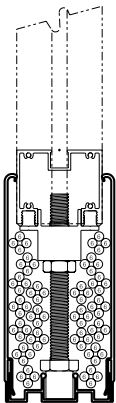

80 Cat. 6

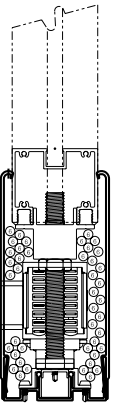

43 Cat. 6  
 With Duplex  
 Receptacle on 1 Side

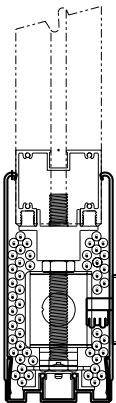

50 Cat. 6  
 With Communication  
 Box

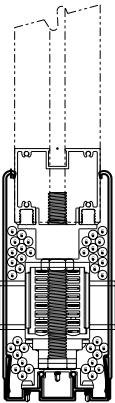

38 Cat. 6  
 Duplex  
 Receptacles  
 on 2 Sides



## Horizontal Power Capacity and Routing

Power can be routed horizontally using PowerPac connectors . In the 6" Vinyl Base, two PowerPac connectors can be run in the same base cavity, however there cannot be two End Blocks or Power Blocks adjacent in the same location.

Power connectors can be run in a continuous chain through straight panel runs and 90° Vertical Connectors. Allow an additional 3" to the PowerPac length for routing through a 90° condition. Measure power runs from center panel to center panel.

### Power | PowerPac Connectors

The PowerPac Connector distributes up to four 20 amp circuits and attaches to a Power Block at any one of the four distribution connections. All PowerPac connections are male; End Blocks are used to join connectors end-to-end or to join a connector to a power feed. Connectors are available in lengths from 18" to 144" in 6" increments. When specifying a run of power connectors that will be connected by Power Block(s), measure the distance between Power Blocks. (See page 36 for more information on measurement.) UL listed and CSA certified. Note: Use an End Block to connect one PowerPac Connector to another PowerPac Connector or to a Power Feed only.

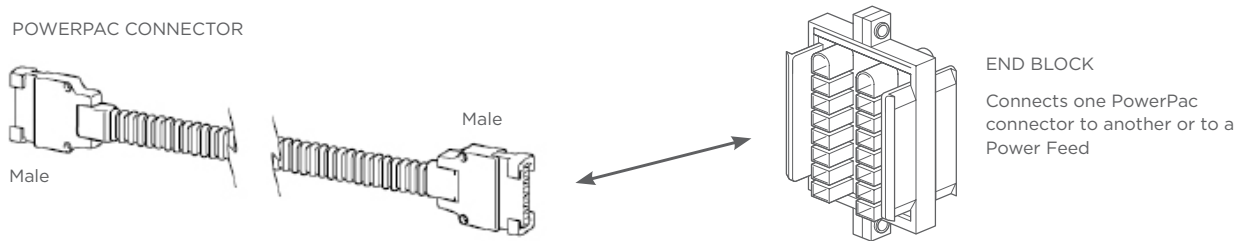

## Horizontal Power Access | Horizontal Power Blocks

Horizontal Power Block with Base Cover is available as either a single or a double and accepts any Volo duplex. It distributes up to four 20 amp circuits. UL listed and CSA Certified. It mounts to the Floor Runners. These are dual sided and can ONLY work inside a 6" Vinyl Base. Power Block with Base Cover ships with one 12' long 6" Vinyl Base section that can be cut to fit the specific application.

The Base Cover has single (VPBB6INS) or double (VPBB6INS) punch outs centered at 24" from each end.

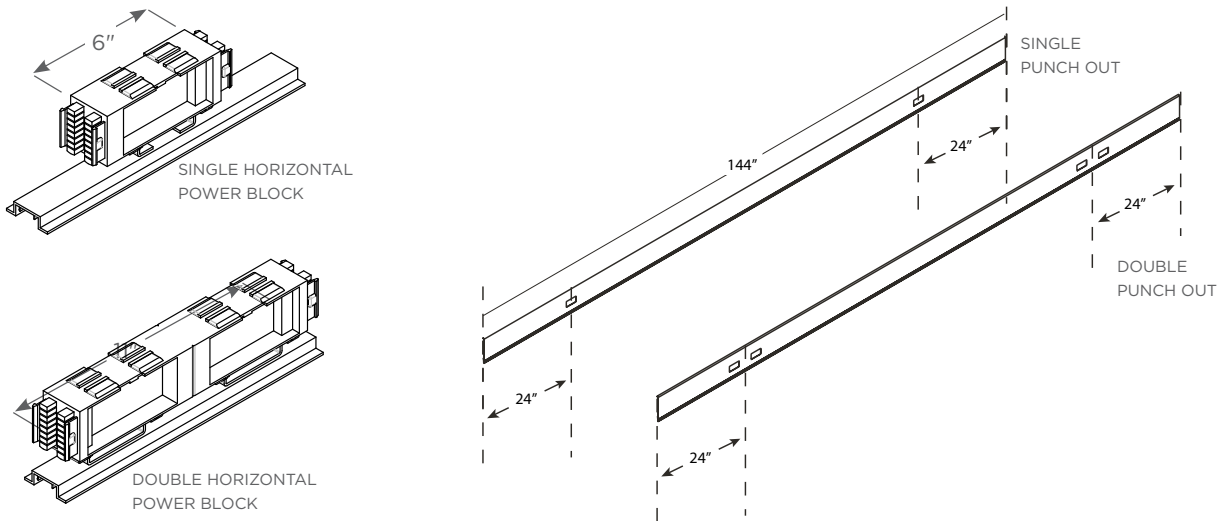

### HARD WIRE POWER / DATA / LOW VOLTAGE:

The Volo Communication Box can be mounted horizontally inside the 6" Vinyl Base to allow for either building hard wire, data feeds or low voltage applications. Note: cannot be used back-to-back.

There are two ways to manage Data Plates with the Volo 6" Base:

1. Order the Volo Communication Box (VEOCB), which mounts on the Floor Runner behind the Base Cover. Run cables and rough-cut an opening through the Cover where the Box location is desired. Use the data Cover Plate assembly that attaches directly into the Box, allowing cable access through the Base Cover.
2. Order the Volo Communication Box (VEOCB), which mounts on the Floor Runner behind the 6" Base Cover. Run cables and install your Decora styled data outlets directly to the box. Order Base Trim (VCHBT6ES) with Single Block cutouts (Decora style). Cut and fit the Cover section into your panel run at the desired location.

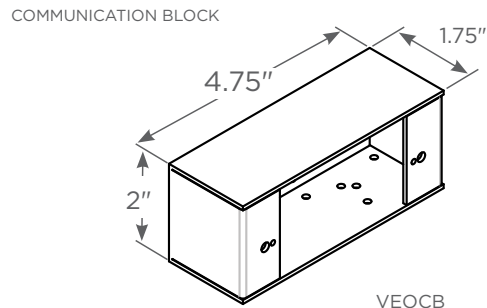

VEOCB



Data Cover Plate

Decora Data Outlet

## Power Specification | Steps and Calculations

### SPECIFICATION STEPS - EXAMPLE

- 1 Insert Power Block where customer has requested power access. See page 37 for Panel Base dimension restrictions.
- 2 Insert Ceiling Feeds as needed through Vertical Connector direct to a Power Block. Ceiling Feeds are available in a variety of lengths to accommodate most needs, from 10' to 50'. (See calculation example on the following page.)
  - a) Check J Box location and distance from the Vertical Connector
  - b) Add ceiling height plus the distance to the first Power Block
- 3 Measure the distance between Power Blocks on your plan, and add 3" for each corner, 3-way, 4-way and inline connector. Select corresponding lengths from the catalog.
- 4 Add receptacles (4 circuits available). Check with your electrician to validate the building supply.
- 5 Add Communications Boxes as needed. Box accepts standard data plates. Validate with the customer's Data supplier.

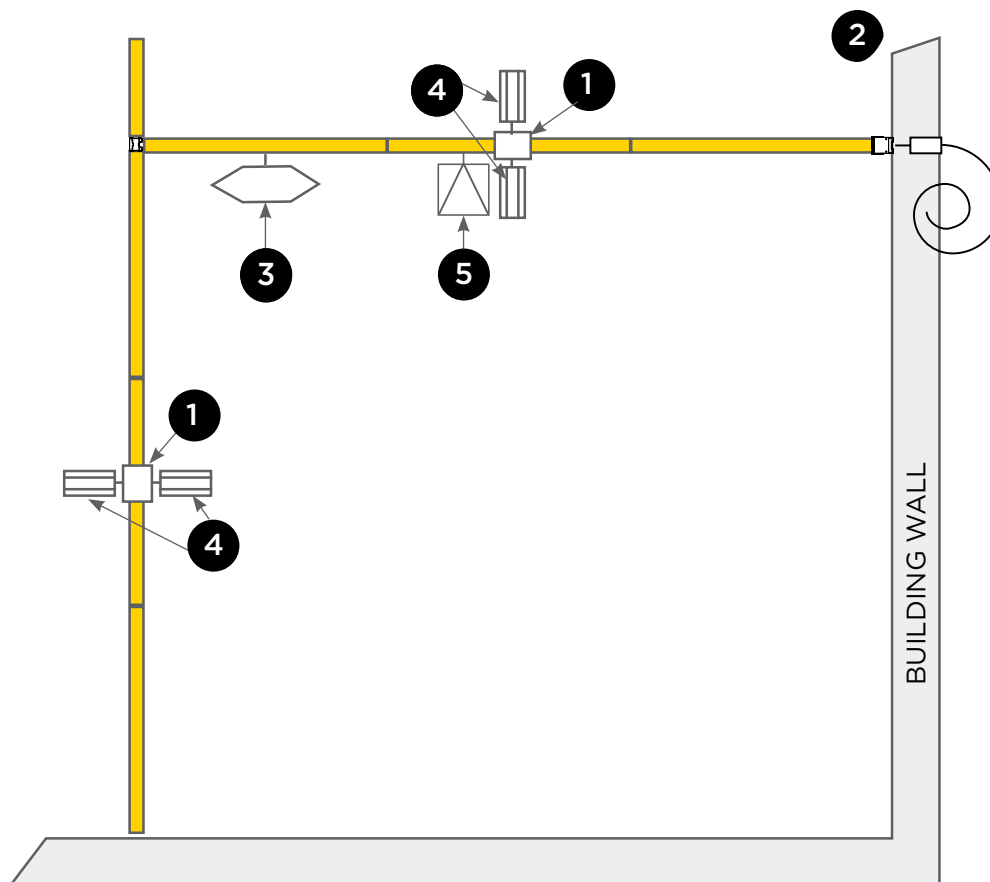
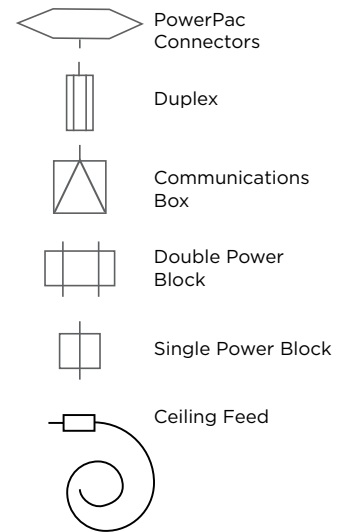

## Power Specification | Calculating PowerPac Connector Lengths

NOTE: all measurements are based on center-panel-to-center-panel. Round connector measurement to the closest available Connector length; Connectors offer +1" of adjustability. When in doubt order larger.

- 1 Specify the Ceiling Feed long enough to reach the first Power Block. See example calculation below.
- 2 Measure the distance between Power Blocks and order the appropriate length Connectors. Round up. Add 3" for each corner, 3-way, 4-way and inline connector.

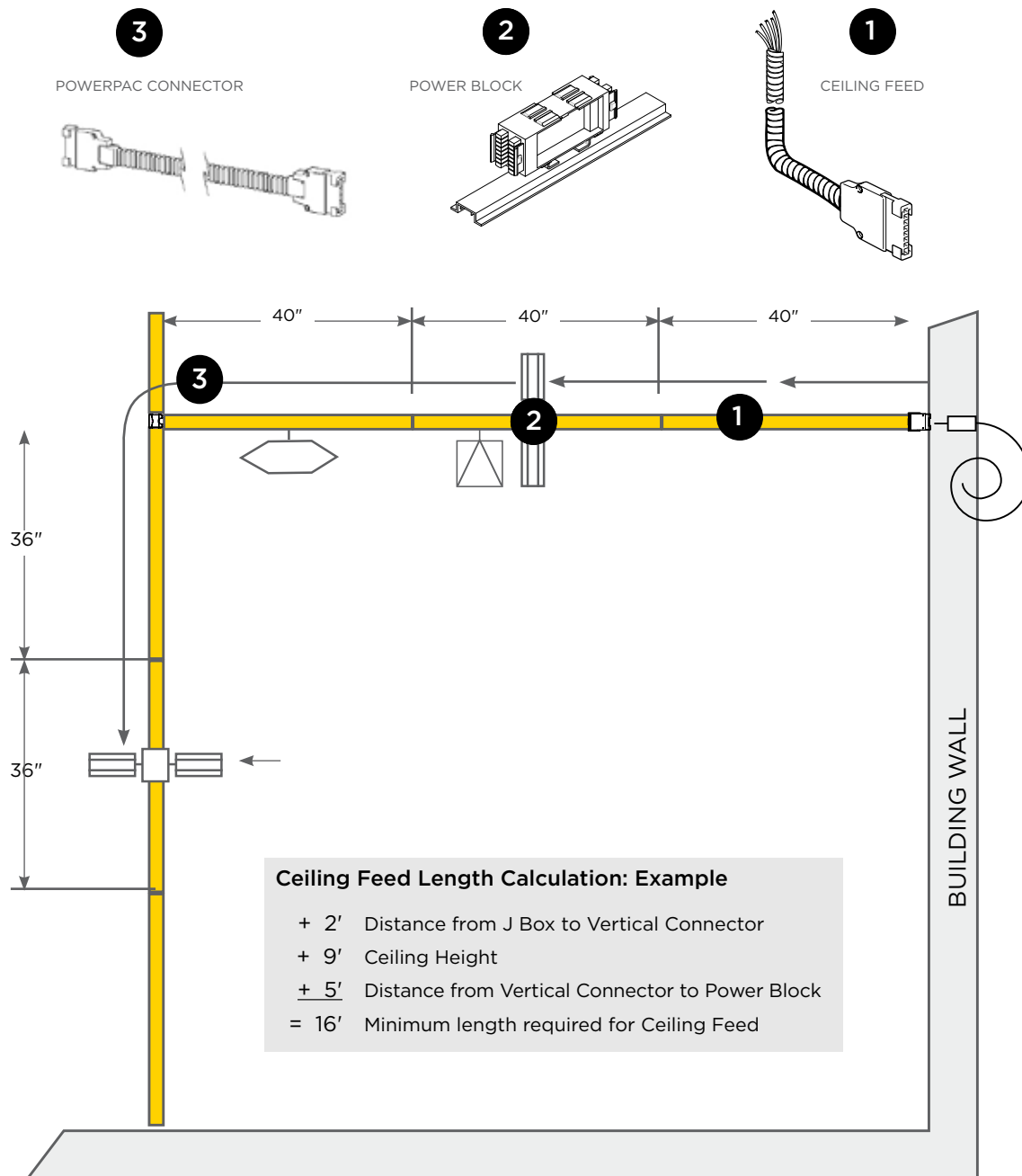

## Power Specification | Panel Base and Block Dimensions

Use the chart and diagrams below to determine the number and size of Power Block/Communication Box elements your layout will accommodate.

Nominal Panel Width	Dimension A	Dimension B	Dimension C
18"	17-15/16"	8-15/16"	5-11/16"
24"	23-15/16"	14-15/16"	11-11/16"
30"	29-15/16"	20-15/16"	17-11/16"
36"	35-15/16"	26-15/16"	23-11/16"
42"	41-15/16"	32-15/16"	29-11/16"
48"	47-15/16"	38-15/16"	35-11/16"
54"	53-15/16"	44-15/16"	41-11/16"
60"	59-15/16"	50-15/16"	47-11/16"

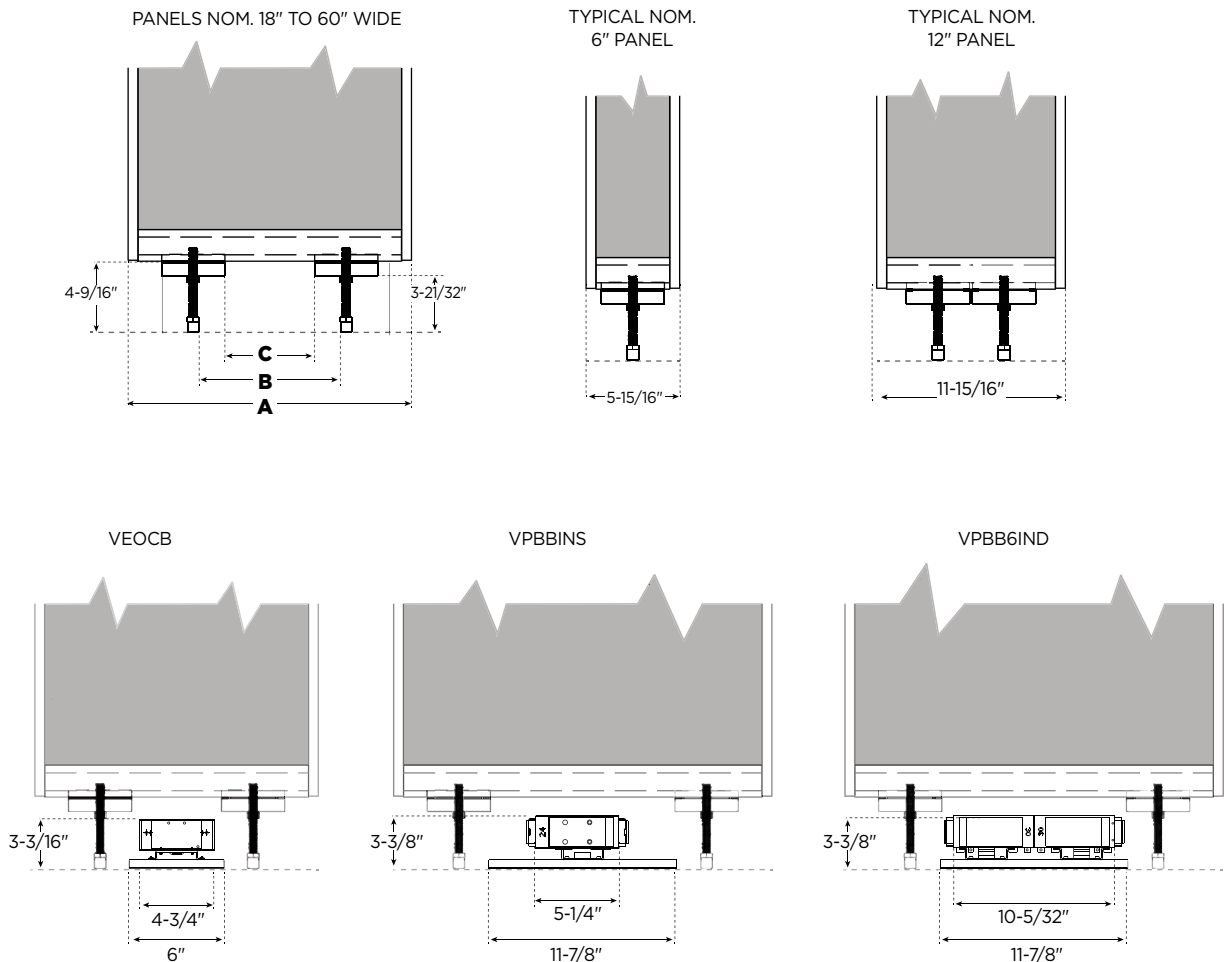

# Acoustics

## Acoustics 101 | The basics.

- You need to strike a balance between how much sound and how much silence is right for your space.
- Acoustics are described in several ways:
  - **Noise Reduction Coefficient (NRC)**, a single-number rating used in specification and product descriptions to show the sound-absorbing capabilities of a particular material. A material is classified as a sound absorber if it has an NRC value of at least 0.40. Porous materials, like fiberglass batt, have high NRC ratings.
  - **Sound Transmission Class (STC )**, a single number system used to rate the airborne sound transmission performance of a product like a wall, panel or ceiling. The higher the STC number, the better the product's ability to block sound transmission. Specifiers should not assume that a panel or partition with a higher STC rating is functionally better than one with a slightly lower rating, because a two- or three-point difference in STC ratings is not detectable by the human ear.
  - **Noise Criteria (NC)** is the measurement of background noise in specific interior environments. Because too much quiet can be as distracting as too much noise, the ideal work environment provides a healthy balance between the two.

### Typical Background Noise Levels

Boardroom	NC -30
Auditorium	NC -30
Video/conference room	NC -30
Typical conference room	NC -30
Private office	NC -35-38
Open plan office	NC -38-40
Public areas	NC -40-55

- **Speech Privacy Potential (SPP)** is the measurement of how much privacy can be achieved from one area to another. SPP is calculated by adding together the STC and NC ratings. As shown in the chart below, an SPP less than 60 provides no privacy, while an SPP of 85 provides maximum privacy.

Privacy Rating	SPP Potential	Description
Total privacy	85	Shouting is barely audible.
Highly confidential	80	Normal levels not audible. Raised voices barely audible but not intelligible.
Excellent	75	Normal voice levels barely audible. Raised voices audible but mostly unintelligible.
Good	70	Normal voices are audible but unintelligible most of the time. Raised voices are mostly unintelligible.
Fair	65	Normal voices audible and intelligible some of the time. Raised voices are intelligible.

ACOUSTIC PERFORMANCE AND VOLO | Volo has the capacity to provide acoustic privacy as good as or surpassing drywall. As a general rule, average conventional drywall has an STC rating range of 36 to 42.

## Volo STC Ratings

### Solid Panels

- Outsert side 1/Insert side 2: STC 43
- Outserts both sides: STC 42
- Inserts both sides: STC 41

### Glass Panels

- Monolithic Clear Tempered: STC 30
- Monolithic Clear Laminated: STC 35

## Volo Speech Privacy Performance

Adjoining Area	NC	SPP	Privacy
Public Areas	40-45	80-85	Total Privacy
Open Plan Offices	38-40	78-80	Highly Confidential
Private Offices	35-38	75-78	Excellent

## Office Partition Construction and Performance Levels

Other Construction Method	STC
Drywall partition up to acoustical ceiling line	STC -30
Drywall partition through acoustical ceiling 6"	STC -35
Drywall partition with insulation, full height up to slab	STC -40-45
Multiple layered drywall with insulation, full height up to slab	STC -45+

## Tips for maximum audio privacy with Volo:

- Use solid Outsert or Insert tiles.
- If glazing is required, specify Laminated Glass.
- Rectangular spaces diffuse sound better than square ones.
- Select Swing Doors vs Sliding Doors.
- For peak privacy, Volo should be paired with acoustical ceiling tiles that have a minimum CAC or CSTC rating of 40 and a minimum NRC rating of .65.
- Batt insulation can also be inserted above the ceiling tiles over a Volo office.

# Volo Installation

## Trendway field support

Trendway offers Field Technical Support for a nominal fee. Approved Trendway Technicians can take field measurements, train and lead during the actual installation at the customer location. Using this resource assures accurate product design and planning, as well as fast, expert installation. Contact the Trendway Architectural Product team for more details.

**Please note:** This is an overview summary of a typical installation. Every project is different. Detailed installation drawings and instructions are available on Trenddealer.

**Important: Inspect the contents of all containers for shipping/handling damage. Make sure you have all required parts before proceeding.**

## Recommended Installation Tools

### Saws

- Hole Saw for Metal — 1"
- Miter Saw 10" or 12" with 80 to 100 Fine Tooth Aluminum Cutting Blades
- Portable Band Saw with Extension Cord
- (18 or 24 Tooth Blade)
- Reciprocating Saw or Jig Saw with 4 -1/2" Metal Cutting Blade

### Tools

- Allen wrenches - Standard and Metric Set
- Channel Lock Pliers
- Cordless Drill with Phillips Head Driver Bits - #2 and #3
- Counter sink metal drill bit
- Drill Bit Set with long 1/8" drill bit
- File
- Hammer Drill
- Masonry Drill Bits — 5/32" and 5/16"
- Nut driver — 1/4" and 5/16" (magnetic preferred)
- Nylon Mallet
- Putty Knife — 2" and 6"
- Quick Clamps — set of (2)
- Screw driver — 1/8" Flat Head
- Steel Hammer
- Tin Snips (set)
- Utility Knife
- Wrench — Open end wrench - 3/4" 15 mm (as thin as possible) or Crescent wrench

### Other

- Ladders — 2' to 6'
- Level (4' preferred)
- Masking Tape
- Plumb Bob (Laser preferred)
- Saw Horses with drop cloth
- Combination Square
- Tape Measure - Steel
- Glass cleaner and Paper towels
- Glass Suction Cups
- Safety Glasses
- Shop Vac/Vacuum



## Special Note: Freestanding Applications

---

NOTE: When planning for a Volo application that is not attached to a ceiling, the Freestanding Volo Kit contains the parts needed to effectively provide the additional structural integrity required for freestanding capability. Order part number VFCK. **This method adds the rigidity necessary for a freestanding wall up to a 12' run. If you desire other dimensions, contact your Trendway Architectural Specialist and design team for help. Refer to Installation Sheet [INS659](#) for the proper installation sequence.**

In general, additional reinforcement must be added at the top of the panel run for stability in freestanding applications. The Freestanding Volo Kit contains the parts needed to effectively provide the additional structural integrity required for freestanding capability. Order part number VFCK. **NOTE: Reveal Wall Starts cannot be used in freestanding applications.**

- For 4" and 6" Vinyl Base, install panels into the Floor Runner with panel connecting clips as instructed for the chosen style.
- Using screws, install Stabilizing Blocks to the tops of the panels.
- Install Traditional Crown, placing it over the Stabilizing Blocks in the panel Top Rail.
- This method adds the rigidity necessary for a freestanding wall up to a 12' run. If you desire other dimensions, contact your Trendway Architectural Specialist and design team for help.

## STEP 1: Ceiling Crown and Floor Runner

---

### Crown

- Use a laser level to create a layout on the ceiling based on your floor plan
- Cut Ceiling Crown with open edge face down.
- Attach the crown to the ceiling grid with screws provided, or with the appropriate anchor type for the ceiling type. For Tegular Tile grid ceilings, use the appropriate size Grid Block specified for the type of Crown being installed (part numbers VRGBLOCK14, VRGBLOCK38, VTGBLOCK14 and VTGBLOCKS38 and VRGBLOCKS14, VRGBLOCKS38, VTGBLOCKS14 and VTGBLOCKS38).

### Floor Runner (For panels with 4" or 6" Vinyl Base Frames only)

- Use a laser level to drop a line from the crown to the floor for accurate placement below the crown. Use masking tape to mark panel and door section locations.
- Using a saw, cut Floor Runner to length for each panel or continuous panel run.
- Floor Runner does not go under the Corner, 2-Way, 3-Way, 4-Way connectors; all connectors go to the floor. When a panel is adjacent to a connector, cut the Runner to leave a 1-1/4" gap from the center point of the connector location. At the inside of 90 conditions, add 1/4" to the gap.
- Carpet Gripper will ship with the frame for installing on carpet, if needed. Hard floor surfaces accept double-faced adhesive tape, 2" pieces at the ends and at 4" on center.

### Floor Runner (For panels with Aluminum Base only)

- Aluminum Base panels come with Floor Runner attached plus one Carpet Gripper for install on carpet, if needed.
- Use a laser level to drop a line from the crown to the floor for accurate placement below the crown. Be sure to mark the locations for all panel and door sections.

## STEP 2: Wall Starts

---

### Reveal Wall Start

- Locate the Wall Start as specified on the plan.
- Slide the Reveal Wall Start into the grooves on the side of the Panel Frame that will abut the building wall condition. It creates a finished appearance and allows 1/2" of adjustability. Reveal Wall Starts typically do not attach to the building wall.

### Adjustable Wall Start

- The Adjustable Wall Start has two parts, the Wall Start Channel and the Adjustable Connector Cap.
- The Adjustable wall start is planned with a 2-1/2" offset from the adjacent building partition wall. It can adjust to fill a gap of from 2-1/16" to 3-1/16" between the building wall and the first panel.
- Locate the Wall Start as specified on the plan.
- The Wall Start Channel attaches to the building drywall with anchors appropriate to the building conditions.
- The Adjustable Connector Cap connects to the side of the Panel Frame that will abut the building wall condition using Connector Clips (description follows).

## STEP 3: Install Panel

---

- Raise panel upright and tilt into position under the Ceiling Crown.
- For 4" and 6" Vinyl Base panels: Slide up inside the Ceiling Crown. Lift panel until feet nest inside the middle track of the floor runner.
- Using a 3/4" wrench, adjust panel feet to plumb and level panels so all horizontal rails and cross rails are level and aligned with each other.
- Adjust leveling glides to compensate for irregularities in the floor and or ceiling, The panels can adjust down (shorter) 1/2" or up (taller) by 1-1/4". Adjustment at floor level maintains horizontal tile alignments.
- Continue setting and leveling panels. Leave 1/16" gap between panels to place panel clips.
- Install panel clips between panels, starting at the base line. Slip the first clip up into the 1/16" gap between panels. Slide it up 12" using a putty knife, and leave the putty knife in position to stabilize the connection until the next clip is inserted.
- Repeat, continuing to push each upward. Use a minimum of 4 clips, 5 clips with panels 9' or taller.
- Slide the first clip up to approximately 12" below the crown, then slide the rest into positions evenly spaced between the lowest and highest clips.

## STEP 4: Modular Connectors

---

- Modular Connectors connect 2 or more wall runs at 90, 120, 180 or 135 degrees and provide a vertical raceway chase for power/data cabling. They install using Connector Clips the same as Panel Frames.
- Cut the Connectors, at the top end, to a length equal to the height from the floor to 1/2" below the Ceiling Crown.
- The Connector Covers are cut to match the height of the Panel Frames to the floor and snapped onto the connectors after all panel connections are made.

## STEP 5: Electrical

---

- Power and data can be run and accessed vertically through Inline Connectors. These include covers that can be ordered with electrical punch-outs or open duplex boxes. **Modular power may not be utilized in vertical Inline Connectors; power must be hard-wired onsite by a qualified electrician.**
- Power Feeds (Ceiling or Base), PowerPac Connectors, Power Blocks and Duplexes provide power throughout the panel layout in the 6" Vinyl Base.
- In 6" Vinyl Base panels, power can be run horizontally in the space above the floor runner and accessed with Power Blocks.
- Locate all 6" Vinyl Base electric components as indicated on installation drawings. 6" Vinyl Base Frames provide enough space for the electrical components to be installed during or after the panel install. Building power is accessed via Ceiling Feed or End Mount Base Feed as required.

## STEP 6: Doors

---

### Sliding Section – Single and Double

**Please also refer to the detailed Installation Video available from the AP Technical Support Team.**

The Sliding Door Section includes a Door Frame (structural parts) and a Door Frame Trim kit to create a finished cased opening. Trim Kit consists of 2 notched vertical jambs and 1 header piece. It includes Door Track, Valences and Receiver Post with cover. NOTE: If the Sliding Door will be positioned over Outsert Tiles when opened, a Sliding Door Outsert Kit must be specified (SIVSDOUTKIT). The Kit includes spacers that will ensure proper clearance between the door and the tiles. **See also Installation Sheet INS596.**

The Sliding Door Frame looks like an aluminum trimmed cased opening in the wall when installed. It consists of 2 vertical stiles and a horizontal rail at the header, with 2 adjustable feet at the bottom of the stiles. It is field-assembled using screws provided.

*continued next page*

### Sliding Section *continued*

- Insert the frame into or over the Ceiling Crown like any other Panel Frame. Adjust the feet so that the top rail aligns with the panels next to it. Attach the Frame to the other panels (or connectors) with the Panel Clips as you would any Volo panel.
- The 2 vertical jambs are pre-cut to the height needed for your door opening. Install the left side, then the header piece and right side jamb. The 2 vertical jambs are notched at the top to receive the square cut header. Once inserted, they hold in place with a friction fit. If the fit seems loose, insert 2-sided tape for added stability. Stop here if a cased frame is desired.
- Using a helper or good clamps, hold the Strike jamb up to the Vertical jamb. Position it to be 1/4" inside the door opening. Clamp it in place. Drill and attach the jamb into the vertical jamb with the screws provided.
- Cut the Vertical Cover to the same height as the panel assembly. Gently tap the cover into place.
- The 1" wide Door Guide mounts with screws to the stile of the door jamb that is furthest from the door handle. Leave a 1/2" gap between faces to accommodate acoustic seal.
- Figure the length of the Sliding Track and valance, based on your layout. The design calls for you to align the ends with panel joints and cut the Track 2" less than that number. Cut the snap-on valances that length next.
- Using a helper or good clamps, hold the track, with the back valance already snapped on, up to the wall and clamp it in place. Pre-drill and screw attach the track with the screws provided.

## Doors

### Sliding Door

**NOTE: find detailed drawings in the Installation Instructions document INS596 on Trendeleer.**

**NOTE:** Sliding Doors cannot install adjacent to a Reveal Wall Start without a minimum 6" panel between them.

- First, align the ends of the Door Track with the panel joints. Measure the distance between the panel joint opposite the door handle and edge of the vertical cover.
- Cut the two Valance pieces (one is installed after the door is hung) to this length. Cut the Door Track 2" shorter than that.
- Clip the inside Valance into place in the groove on top of the Door Track. Clamp the assembled parts in position on the Door Frame rail. Drill and attach with screws supplied.
- Slide one of the provided door stoppers into the track, spring leg facing out.
- Attach the Wheel Sets to the top of your door.
- Using a helper, move the door over to the track and slide the wheel sets into the track. Spinning the Wheel Sets on their hanger bolt up or down provides about 1/4" adjustment on the overall door height.
- Slide the second door stopper in behind the door, with the spring end facing in.
- Install the End Caps into the open end of the door valances. Put a screw through the valance legs into the caps to secure them.
- Install door hardware, adjust door stops as needed to allow a minimum of 1.5" between the handle and the frame as required by ADA.

## Frameless Glass Sliding Door

**NOTE: find detailed drawings in the Installation Instructions document INS654 on Trendealer.**

### SLIDING DOOR TRACK INSTRUCTIONS

1. Measure and cut the Track to the desired length. Valances should be cut to the full desired length, and the Track should be cut an inch shorter to allow room for the End Cap.
2. On saw horses, with carpet or cloth to protect the finish, lay one of the Valances face down, then roll and snap the Track into the Valance (larger holes up). Push the Track on the Valance to ensure it is properly located on the Track, 1" from the end of the Valance that will have the End Cap attached to it. With a long or extended 3/16" Drill Bit, using the holes in the Track as a guide, drill through the Valance below, in the locations used to mount the rail and Valance.
3. Use clamps and a helper to mount the Track/Valance set onto the Crown Assembly. The top of the Track should be 1/16" below the ceiling. Line the end of the track up to be flush with the door post. Adjust across the length of the Track to make sure it is level. Pre-drill through the Crown Cover with the 3/16" Drill Bit, then, using the 10-16x1.5" Hex Head Drill Point Screws provided, attach the Track and Valance to the Crown Assembly securely.
4. Identify top and outside of Door. Bottom Pull mounting hole is 40.00" from the bottom of the Door on Doors with 18" Post Pulls, 43.75" on Doors with 36" Post Pulls, and 7" on Doors with 72" Ladder Pulls. Place Clamps on top face of door with fasteners facing the outside. The outer edges of the Clamps should be 2" from the glass sides. Tighten all set screws.
5. Slide Trolley bolts into Clamp slots, centering the Trolleys on the clamps. Tighten nuts to secure the Trolleys to the Clamps. Align top of bolt to be flush with top face of Trolley. Clamp Soft Close(s) onto Trolley(s).
6. Slide one of the Door Stops in so that the Trolleys will run into the Spring Clip first, then the bumper.
7. Lift the door and carefully slide each of the wheel sets into the track.  
**NOTE: If Track ends are too close to a wall for door to have clearance, install Trolleys with Soft Close(s) into the Track, and tighten the Clamps onto the Door separately. Lift the Door onto the Trolley bolts and tighten the nuts.**
8. The Door should be a nominal 3/4" above the floor. Check to ensure the Door is plumbed. This can be adjusted by loosening the nut on the Trolley bolt, turning the bolt, and retightening the nut once leveling is achieved. **NOTE: At least four full Trolley bolt threads must be engaged in each Trolley.**
9. Install Clamp Covers. Slide the top flange onto the Clamp grooves and center on the glass. Use the #6-20 x 5/8" Square Drive Screws to install the End Covers.
10. Attach the Door Guide from the Mounting Hardware Kit to the Door Guide Bracket using the #8-32 x 1/4" Flathead Screws. Ensure the Door Guide is fully opened by loosening the side screws. Install the Door Guide, using a level to make the Door plumb. Start by only using the fastener in the slot. This will allow adjustment later if needed. Drill a pilot hole with a 7/64" bit and thread in a #6-18 x 5/8" Square Drive Screw.

11. Measure between the floor and the bottom of the Clamp Covers and cut the Acoustic Wiper and Mount to this length. Peel the backing off the double stick tape and apply pressure for 30 seconds to properly adhere it to the Jamb Post. The Acoustic Wiper Mount should align with the back of the Door Jamb Post.
12. Insert the trailing Door Stop into the Track so that the Trolley will run into the Spring Clip first, then the bumper.
13. Install the Door Handle provided using the included set screws and Allen Wrench.
14. If installing a Patch Lock, measure from the floor to the centerline of the lock cutout in the door and subtract 1". Measure from the bottom of the slot cutout in the receiver post downward and cut at this dimension.
15. Measure from the floor to the top of the track and cut the receiver post to that length from the top. **NOTE: If installing a door with a patch lock, remove the Bumper Strip from the Receiver Post before mounting it.**
16. Pre-drill (5) holes in the Strike Receiver Post, 5/8" inset from the back of the post and evenly spaced from top to bottom on the side that will mount on the Door Jamb, using the long 1/8" Drill Bit. **NOTE: Once the Strike Post is drilled, it becomes handed.**
17. Butt the Strike Receiver Post up to the track, flush with the opening of the door frame (ensuring the Strike Receiver Post is plumb with the level). Using the 1/8" pre-drilled holes, drill through with the long 1/8" Drill Bit and screw a minimum of five (5) equally spaced #6-18 x 1" Square Drive Screws through the back of the post and into the door frame to stabilize the post.
18. Use the Post to Track L bracket to secure the Track to the strike post using #7-19x7/16 Screws. Check that the Door fits cleanly into Receiver Post. If the Door needs to shift in or out, loosen the Trolley bolt nut and push the Door in the desired direction before tightening it.
19. Adjust the Door Stops inside the Track to stop the Door in the fully open and fully closed positions. It is suggested that, in the open position, the Door stop with 1.5" between the Handle and the Door Jamb opening. Set the Soft Close pins, following **INS612**.
20. If installing a patch lock, refer to **INS649** for installation instructions. Use the adjustability in the Door Guide Bracket, Door Clamps, and Lock Strike Plate to ensure the Door can lock. Measure the location of the Lock Strike Plate, and mark the necessary lengths for the Bumper Strip before removing the Strike Plate, cutting the Bumper Strip, inserting the Bumper Strip into the Receiver Post through the lock slot, and replacing the Strike Plate.
21. After ensuring the functionality of the Soft Close(s), smooth operation and alignment of the Door, and, if applicable, proper locking, drill the second screw into the Door Guide Bracket to hold its position.
22. Snap on the outside Valance cover. Pre-drill and screw one #7-19x7/16" Screw into the leg of the Valance to hold it securely to the Track.
23. Slide the Track End Cap into the end of the Track and Valances, then pre-drill and screw it securely to the Valance leg using a #7-19x7/16" Screw.

## Swing Door Frame

The Swing Door Frame is a specialized panel that includes a Door Panel Kit and a Door Frame Trim kit to support the door opening for the door type selected. The Panel Kit consists of 2 pre-drilled stiles and a header rail. Trim Kit is included with the Door Frame and consists of 2 notched vertical jambs and 1 header piece. All required hardware is included. For Single Swing Door see Installation Sheet INS594 for details, or view the detailed Installation Video available from the Trendway Technical Team. **Installation instructions for Double Swing Doors are available as a detailed Installation Video only, also available from the Trendway Technical Team.**

- Assemble the Door Frame Kit by putting supplied #6 18 x 1" Flat Head Screws through each of the pre-drilled Stiles, into the Header Rail, being sure to have the 3/8" wide glazing pocket open down into the door opening.
- Screw the 3/8" Bolt into the Hex Coupling Nut. Insure the longer Hex part of the Coupling Nut is facing toward the Bolt. Insert the Adjustable Foot assembly into the Door Frame Stiles, making sure the flat side of the washer side faces the door side.
- Plumb down from ceiling track and Install your Jamb to Floor Runners in the door frame opening using 1x1/4" Tapcon type concrete Screws . The front face of the Jamb to Floor Runner should be 1x5/8" from the aluminum frame of the adjacent panel. The distance between Jamb to Floor Runners should be 36 1/4" face to face.
- With both Runners installed, stand your assembled door frame panel into your opening. Adjust the Foot Bolts at the floor so that the top rail of the panel aligns perfectly with the panel or panels to either side. Check that Header is level.
- Install 8 Panel Connector Clips on Hinge side, 3 at top, 2 at 3/4 up, 2 at 1/2 up, and 1 at bottom. Then install 5 Panel Connector Clips on the Strike side, evenly spaced from top to bottom to insure a positive and accurate install of the panel frame. These 5 Panel Connector Clips come from the adjacent panel and are not in the Door Frame hardware kit.
- Start the Trim Kit install by taking one of the Vertical Jamb Covers, and installing it over the Vertical leg of the Door Frame Panel with U Channel. The Notched end of the jamb goes to the top.
- Install the square cut Header/Transom piece by 1st putting the 2 spring clips into the Header/Transom, then slipping the Header/Transom channel over the Header Rail of the Door Frame and nestling it into the notch of the Vertical Jamb Cover.
- The 3rd piece can now be installed by tipping the notched portion of the jamb under the top rail and into the Header/Transom that is already in place.

**NOTE: Due to floor run, it's important that the Hinge Side Trim Cover be resting on the floor. You may or may not need to trim the bottom of the Jamb Cover. Do Not Trim More than 1/4" of the Jamb Cover.**

## STEP 7: Base Cover and Trim

---

### 2" Vinyl and Aluminum Base Frame

Aluminum Base See also *Installation Sheet INS650*

- Aluminum Base consists of the Base and Base Clip. It comes in 9' sections.
- Measure the base opening. When spanning panels, the Base Clip should always be cut to overlap Floor Runners by at least 6" to ensure proper lineup between adjacent Base Covers.
- Cut Aluminum Base pieces to butt up to all adjacent floor and ceiling components. Note: it is recommended that the Base be cut so that seams between adjacent pieces line up with the center of a seam between panels for a more uniform appearance.
- Install Base Clips by the snapping the groove on one end of the Clip over the edge of the Floor Runner. Use a nylon mallet to tap the rest into position. The entire length of the Clip must be seated: if it feels loose it is not installed correctly.
- Line the Base Cover up to engage with the top of the Base Clip flange. Use a wood block and nylon mallet to push it down over the Base Clip.

### 2" Vinyl Base

- Using a saw, cut base (supplied in 12' sections) to lengths required to minimize seams.
- Measure from the bottom of the panel to the floor and add 1/4" to determine the height of the Base Trim.
- Score the edge at the top of the trim and rip off excess in 1/4" strips to adjust height for a snug fit into the small channels provided on the base rail. Note: notch the top edge 1/8" x 1-1/2" when abutting an Adjustable Wall Start.
- Slip up into place; slip ends under adjacent Vertical Covers. Lightly tap the base into place.
- Snap on Corner and Flat Trim Connector covers where required.

### 4" Vinyl Base Frame

- Using a saw, cut base (supplied in 12' sections) to lengths required to minimize seams. At door frames, allow a 1/8" gap at the door jamb to accept the edge cover plug found in the hardware pack of your door frame kit.
- Base slides onto the leg in the Floor Runner.
- Snap on Corner and Flat Trim Connector covers where required.

### 6" Vinyl Base Frame

- For 6" Vinyl Base, Power Blocks come with 4' sections of pre-punched Base Cover. Install these first. Butt adjacent Base Cover segments up tightly to the powered segment.
- Using a saw, cut base (supplied in 12' sections) to lengths required to create seamless runs. At door frames, allow a 1/8" gap at the door jamb to accept the edge cover plug found in the hardware pack of your door frame kit.
- Base slides into the slot in the Floor Runner.
- Snap on Corner and Flat Trim Connector covers where required.



# Trendway Architectural Products – Frequently Asked Questions

---

## Questions on the Architectural Products Binder

**What is the Architectural Products (AP) binder?** The digital AP binder includes a wealth of AP product information. Dealers and customers can download it from the Documents portion of Design Resources. New requestors provide lead information for sales team followup.

**Why is the AP binder important?** The AP Binder includes the marketing and technical documents you need to sell, specify, and respond to customer requests for documentation. It's all in one place, updated quarterly to ensure the most current information:

- Brochures (TrendWall®, Volo®, AeraMax Pro)
- Cut Sheets - (32 total)
  - Sliding Doors (22)
  - Swing Doors (10)
- Planning Guides (TrendWall®, Volo®)
- Specifications - CSI 10.22.19 Demountable Partitions (TrendWall®, Volo®)
- Resources:
  - AP Codes and Requirements
  - Installation Instructions
  - Master Key information
  - Sustainability documents
  - Volo Typical elevations
- Surface Materials - standard offering for each Wall product line

---

## Questions about AP Hardware

### LOCKS

**NOTE: Trendway offers Small Format Interchangeable Core (SFIC) locks but NOT Large Format Interchangeable Core (LFIC) Locks. Consult the applicable Lock Cut Sheet for technical details.**

**What is the difference between SFIC and LFIC locks?** Both Small Format Interchangeable Core (SFIC) and Large Format Interchangeable Core (LFIC) locks offer interchangeable cores for easy changes in the field. Both have a figure-eight shape. However:

- SFIC is a standard among lock manufacturers, and is always the same size. Both the upper and lower parts of the “figure 8” configuration are the same size. Locks are easily rekeyed with cores from various suppliers. SFIC can be used in a Lever Set SFIC or Mortise SFIC Lock
- The less-flexible LFIC format varies in size. The upper and lower parts of the “figure 8” configuration are different in size. It requires that the door lock or lever set housing be matched to its own same specific brand of replacement core.

## Questions about AP Hardware — continued

### Why does my SFIC Lever Set not work after I've inserted the SFIC Core?

A separate “tailpiece” is shipped to you with the SFIC Lever Set, but it's not installed until the SFIC core is installed (right). This is often overlooked, resulting in a lock that won't function. Refer to SFIC Lever Set Cut Sheets for further clarification.

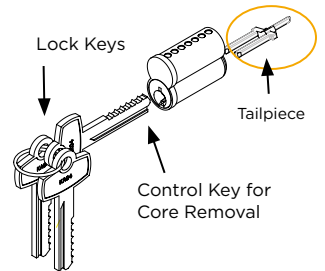

## COM HARDWARE

**Will my COM hardware fit your doors?** Door thickness and the size/location of any present Door machining (Door Prep) will determine if COM hardware will work with Trendway-supplied doors. The requestor should refer to dimensions included in the appropriate Door and Hardware Cut Sheet (found in the AP Binder or on Trenddealer) to determine if the hardware matches the Door Prep, or ask their COM hardware supplier/contact to review the Cut Sheet for a determination.\*

There are three critical specifications found in the Cut Sheet that will determine if COM hardware will fit Trendway-supplied doors. These are all identified in the Door Prep Details portion:

- Door thickness (i.e., 1-3/4" vs 1/2")
- Door machining – locations
- Door machining – opening sizes

---

## Questions about CUSTOM PRODUCT/SPECIALS

### Does Trendway accept Specials (custom product) requests?

Trendway can support two kinds of Specials projects:

1. Simple modifications to existing Trendway product (e.g., Laminate tiles for a TrendWall panel)
2. Moderate modifications to existing Trendway product (e.g., Surface-mounted electrical in a Volo panel).

Trendway **will not accept complex custom AP product requests**, including the following:

- Alternative hardware routing to accommodate COM hardware\*
- Trendway purchase of custom or COM hardware
- Items for outdoor use or entrance/exit applications
- Custom millwork or development of an entirely new product
- Custom or fabricated parts not readily available from suppliers

**PLEASE NOTE:** if desired COM hardware does not fit our standard machined door prep, blank/non-machined doors are available as a standard, including locking versions. These can be machined on-site. See the Planning Guides for details.

## Installation Instructions

Detailed, illustrated Installation Instructions and technical Cut Sheets are available on Trenddealer or in the [on-line AP Binder](#)

### **Panels**

Volo Frameless Glass .....	INS690
Volo Reveal Crown .....	INS590
Volo Traditional Crown .....	INS591
Volo Panel .....	INS595
Volo Lightblock Installation .....	INS597
Volo Glass Markerboard Outserts.....	INS628
Volo Aluminum Base.....	INS650
AeraMax Pro.....	INS679

### **Door, Sliding**

**A detailed Installation Video is available from the Trendway Technical Support Team.**

Volo Reveal Crown .....	INS590
Volo Traditional Crown.....	INS591
Volo Sliding Door Frame and Sliding Door.....	INS596
Sliding Door Soft Close .....	INS612
Volo Freestanding Crown Kit .....	INS659
Post Pull.....	INS651
Volo Frameless Sliding Glass Door.....	INS654
Patch Lock for Frameless Glass Sliding Door .....	INS649

### **Door, Swing**

**A detailed Installation Video is available from the Trendway Technical Support Team for both Single and Double Swing Doors.**

Volo Swing Door Frame .....	INS594
SFIC Core Assembly .....	INS675







CORPORATE | Holland, Michigan | 800.968.5344 | [Trendway.com](https://www.trendway.com)

---

CHICAGO | LOS ANGELES | WASHINGTON, DC