

1.8.1 Batterie

Batteries



Ricambi & accessori per macchine agricole

SPARE PARTS & ACCESSORIES FOR AGRICULTURAL MACHINE

Tutti gli articoli della presente sezione, prodotti da AMA SPA e/o da terzi per conto di AMA, sono adattabili ("non originali") alle marche indicate ai sensi di quanto previsto dal REG. CE n. 1400/2002. I diritti sui marchi citati appartengono ai legittimi proprietari ed il loro uso ha l'esclusiva finalità di consentire all'utilizzatore la comparazione dei diversi prodotti. All items of this section, manufactured by AMA SPA and/or any third party on behalf of AMA, are adaptable ("non-original") to the brands listed under the provisions of the REG. CE n. 1400/2002. The rights on the trademarks belong to their respective owners and their usage is only aimed to allow the user to compare different products.

BATTERIE TUDOR TECHNICA

BATTERIE TUDOR TECHNICA
 TUDOR TECHNICA BATTERIES
 BATERIA TUDOR TECHNICA
 BATERIAS TUDOR TECHNICA



Note: Batterie 12V per autovetture e veicoli commerciali. Senza manutenzione. Carica pronta all'uso.

Notes: 12V batteries for industrial vehicles, agricultural and construction vehicles. Loaded batteries

Art./Ref.	Capacità/Capacity	Spunto/Start	Dimensioni/Sizes	Polarità/Polarity	Note/Note
64000	44Ah	420A	207X175X190	Dx	11,98 kg
64001	50Ah	450A	207X175X190	Dx	12,80 kg
64002	60Ah	540A	242X175X190	Dx	15,09 kg
64003	74Ah	680A	278X175X190	Dx	17,68 kg
69590	95Ah	800A	353X175X190	Dx	22,82 kg
73435	100Ah	720A	306X173X222	Sx	23,54 kg

BATTERIE TUDOR HEAVY PROFESSIONAL

BATTERIE TUDOR HEAVY PROFESSIONAL
 TUDOR HEAVY PROFESSIONAL BATTERIES
 BATTERIE TUDOR HEAVY PROFESSIONAL
 BATERIA TUDOR HEAVY PROFESSIONAL



Note: Batterie 12V per veicoli industriali, trattori e macchine movimento terra. Carica pronta all'uso

Notes: 12V Batteries for industrial vehicles, agricultural and construction vehicles

Art./Ref.	Capacità/Capacity	Spunto/Start	Dimensioni/Sizes	Polarità/Polarity	Note/Note
64004	100Ah	720A	313X175X205	Dx	23,30 kg
85594	110 Ah	750A	349X175X235	Dx	27,10Kg
64005	140Ah	800A	510X175X225	Dx	37,50 kg
64006	140Ah	900A	508X178X205	Dx	35,31 kg
64009	180Ah	1000A	510X218X225	Dx	48,00 kg
85596	180Ah	1000A	513X223X223	Sx	43,20 Kg
64007	155Ah	900A	510X218X225	Dx	45,37 kg
64008	155Ah	900A	513X223X223	Sx	41,93 kg

BATTERIE TUDOR HEAVY PROFESSIONAL POWER

BATTERIE TUDOR HEAVY PROFESSIONAL POWER
 TUDOR HEAVY PROFESSIONAL POWER BATTERIES
 BATTERIE TUDOR HEAVY PROFESSIONAL POWER
 BATERIA TUDOR HEAVY PROFESSIONAL POWER



Note: Batterie 12V per veicoli industriali, trattori e macchine movimento terra. Carica pronta all'uso. Piastre piombo/calcio

Notes: 12V Batteries for industrial vehicles, agricultural and construction vehicles

Art./Ref.	Capacità/Capacity	Spunto/Start	Dimensioni/Sizes	Polarità/Polarity	Note/Note	Tipo/Type
85595	145Ah	900A	513X189X223	Sx	36,11 Kg	IVECO EUROCARGO, TRATTORI JOHN DEERE

BATTERIE MAGNET SERIE MID

BATTERIE MAGNET SERIE MID
 MAGNET SERIE MID BATTERIES
 BATTERIE MAGNET SERIE MID
 BATERIAS MAGNET SERIE MID



Note: Batterie 12V per autovetture e veicoli commerciali. Senza manutenzione. Carica pronta all'uso.

Notes: 12V batteries for industrial vehicles, agricultural and construction vehicles. Loaded batteries

Art./Ref.	Capacità/Capacity	Spunto/Start	Dimensioni/Sizes	Polarità/Polarity	Note/Note
84487	44Ah	360A	207X175X190	Dx	11,40 Kg
84488	60Ah	510A	242X175X190	Dx	14,10 kg
84489	74Ah	640A	278X175X190	Dx	17,00 kg
84490	95Ah	760A	353X175X190	Dx	21,40 kg
84491	100Ah	700A	333X175X215	Dx	23,00 kg

BATTERIE SERIE MAGNET TRUCK

BATTERIE MAGNET TRUCK
 MAGNET TRUCK BATTERIES
 BATTERIE MAGNET TRUCK
 BATERIAS MAGNET TRUCK



Note: Batterie 12V per veicoli industriali, trattori e macchine movimento terra. Carica pronta all'uso

Notes: 12V batteries for industrial vehicles, agricultural and construction vehicles. Loaded batteries

Art./Ref.	Capacità/Capacity	Spunto/Start	Dimensioni/Sizes	Polarità/Polarity	Note/Note
84492	120Ah	680A	510X175X228	Dx	36,50 kg
84493	155Ah	900A	510X218X228	Dx	43,50kg

BATTERIE PER TRATTORINI
BATTERIES POUR TRACTEURS
BATTERIES FOR TRACTORS
BATTERIEN FÜR TRAKTOREN
BATERIAS PARA TRACTORES

Art./Ref.	Misure/Sizes	Volt/Volt	Capacità/Capacity	Spunto/Start	Polarità/Polarity	Tipo/Type	Note/Note	Brand	Rif. Orig./Orig. Ref.
03573	166X89X134	12V	14 Ah	60 Ah	- +	a secco / dry	-	UNIVERSAL	12N143A
32412	162X90X205	12V	18 Ah	100 Ah	- +	a secco/dry	-	UNIVERSAL	12N183A
03581	170X124X184	12V	24 Ah	130 Ah	- +	a secco/dry	-	UNIVERSAL	12N243A
18356	207X130X183	12V	24 Ah	270 Ah	+ -	a secco/dry	-	UNIVERSAL	U19
18357	207X130X183	12V	24 Ah	270 Ah	- +	a secco/dry	-	UNIVERSAL	U1R9
38373	170X124X184	12V	24 Ah	270 Ah	+ -	a secco/dry	-	UNIVERSAL	12N244A
57881	92X70X92	12V	4 Ah	56 Ah	- +	a secco/dry	-	UNIVERSAL	CB4L-B
57882	130X87X150	12V	10 Ah	180 Ah	+ -	senza manut. / maint. free	con flacone di acido / provided with acid	UNIVERSAL	CBTX12-BS
57883	145X87X150	12V	12 Ah	200 Ah	+ -	senza manut. / maint. free	con flacone di acido / provided with acid	UNIVERSAL	CBTX14-BS

BATTERIE AL GEL PER TRATTORINI
BATTERIES A GEL POUR TRACTEURS
GEL BATTERIES FOR TRACTORS
GEL-BATTERIEN FÜR TRAKTOREN
BATERIAS GEL PARA TRACTORES

Note: Sigillate e senza manutenzione

Notes: Sealed maintenance free

Art./Ref.	Misure/Sizes	Volt/Volt	Capacità/Capacity	Polarità/Polarity	Note/Note	Brand	Rif. Orig./Orig. Ref.
32660	167x77x182	12	18 Ah	- +	Castelgarden Twin Cut, Stiga	STIGA	1117201301
32963	167X77X182	12	22 Ah	- +	-	-	-

CARICABATTERIA MPC900

CHARGEUR DE BATTERIES MPC900

BATTERY CHARGER MPC900

BATTERIELADEGER MPC900

CARGADOR DE BATERIAS MPC900

Note: Input: 120Vac 60 Hz; 230Vac 50Hz; 240Vac 50Hz**Output:** 12Vdc 900 mA

6V/12V volt con switch

Funzione di mantenimento automatico

Tre livelli di controllo carica

Nono sovraccarica la batteria

Protezione dai corti circuiti, sovraccarichi e da polarità inversa

Fornito con doppi terminali a clip e anelli.

Adatto anche per batterie al gel

Notes: Input: 120Vac 60 Hz; 230Vac 50Hz; 240Vac 50Hz**Output:** 12Vdc 900 mA

6V/12V volt switch

Automatic Maintenance

Three level charge control

Never overcharge your battery

Output short circuit, reverse polarity and overload protection

Output clips and ring terminals provided

Suitable also for Gel batteries



Art./Ref.

79097

CARICA BATTERIA CON CONTROLLO PICCHI DI TENSIONE

CHARGEUR DE BATTERIE AVEC CONTRÔLE DE LA TENSION

BATTERY CHARGER WITH VOLTAGE CONTROL

BATTERIELADEGERÄT MIT SPANNUNGSREGELUNG

CARGADOR DE BATERIA CON CONTROL DE VOLTAJE



Note: Adatto alla ricarica di batterie al piombo: WET con e senza manutenzione, AGM, GEL, Ca/Ca SAFE CHARGE & BOOST: il sistema protegge l'elettronica montata nei veicoli da eventuali interferenze e sovra-tensioni che potrebbero generarsi durante la carica o durante l'avviamento rapido. FLOATING: può essere tenuto collegato alla batteria per un tempo prolungato. Mantiene la batteria pronta all'uso. REGOLAZIONE FINE DELLA CORRENTE: consente di caricare in maniera ottimale le batterie di tutte le capacità (Ah). Carica con timer, comando a distanza per l'avviamento, voltmetro/amperometro digitale, protezione termostatica a riarmo automatico, protezione contro le inversioni di polarità e corto circuiti, pinze heavy duty.

Notes: Suitable for charging lead batteries: WET serviceable and maintenance free, AGM, GEL, Ca/Ca SEFE CHARGE & BOOSTS: the system protects the electronic components on the vehicle against interference and overvoltage that may be created at the charging or quick starting procedures. FLOATING: can remain connected to the battery for a long time. Batteries are ready to use all times. CONTINUOUSLY ADJUSTABLE CHARGE CURRENT: lets you charge optimally batteries of all capacities (Ah). Charging with timer, boosting remote control, digital voltmeter/ammeter, overload protection with automatic reset, inversion of polarity and short circuits protection, heavy duty clamps.

Art./Ref.	Alimentazione/Voltage	Kw/Kw	Tensione nominale V/Nominal voltage V	Corrente carica efficace/Effective charging power	Corrente carica media/Average charging power	Capacità nominale/Rated capacity	Posizione carica/Charge position	Altezza mm/Height mm	Larghezza mm/Width mm	Profondità mm/Depth mm	Peso Kg/Weight Kg
85491	230V 50Hz	1,7/16,8	12/24	80	50	5-1000	Stepless	903	390	280	26,7

CARICA BATTERIE COMPATTO PORTATILE

CHARGEUR DE BATTERIE

PORTABLE BATTERY CHARGER

BATTERIELADE

CARGADOR DE BATERÍA AUTOMÁTICO



Note: Tipi di batterie ricaricabili: al Pb Wet con e senza manutenzione, Pb AGM, Gel. Protezione contro le inversioni di polarità. Protezione contro i corto circuiti alle pinze.

Notes: Rechargeable battery types Pb WET maintenance free, Pb AGM, Gel. Protection against polarity reversal. Protection against short-circuiting.

Art./Ref.	Alimentazione/Voltage	Kw/Kw	Tensione nominale V/Nominal voltage V	Corrente carica efficace/Effective charging power	Capacità nominale/Rated capacity	Corrente carica media/Average charging power	Posizione carica/Charge position	Altezza mm/Height mm	Larghezza mm/Width mm	Profondità mm/Depth mm	Peso Kg/Weight Kg
83950	230V-50hz	530W	6/12/24	22	15-260	3,5-7,0-15,0	3	126,5	312	172,5	6,35

CARICA BATTERIE CON AVVIAMENTO RAPIDO

CHARGEUR DE BATTERIE POUR DEMARRAGE RAPIDE

BATTERY CHARGER WITH STARTER FOR QUICK BOOSTING

BATTERIE-LADEGERÄT MIT STARTER

CARGADOR DE BATERIA CON ARRANQUE RAPIDO



Art./Ref.	Alimentazione/Voltage	Kw/Kw	Tensione nominale V/Nominal voltage V	Corrente carica efficace/Effective charging power	Corrente carica media/Average charging power	Capacità nominale/Rated capacity	Posizione carica/Charge position	Altezza mm/Height mm	Larghezza mm/Width mm	Profondità mm/Depth mm	Peso Kg/Weight Kg
61498	230V/400V-50hz	2,5/20KW	12/24	90/100	90/100	35/1300	5	470	750	320	45

CARICA BATTERIE CON AVVIAMENTO RAPIDO (PER LA CARICA DI ACCUMULATORI AL PIOMBO)

CHARGEUR DE BATTERIES AVEC DÉMARRAGE RAPIDE POUR LA CHARGE DE BATTERIES AU PLOMB
 BATTERY CHARGER WITH RAPID STARTER FOR CHARGING LEAD ACCUMULATORS AND QUICK BOOSTING
 BATTERIELADEGERÄT MIT SARTHILFEVORRICHTUNG, ZUM LADEN VON BLEIBATTERIEN UND SCHNELLSTARTEN
 CARGADOR DE BATERIA CON ARRANQUE RÁPIDO PARA LA CARGA DE UN ACUMULADOR DE PLOMO



Note: Protezione termostatica. Protezione contro i corto circuiti. Protezione contro le inversioni di polarità. Tipi di batterie ricaricabili: al Pb Wet con e senza manutenzione, Pb AGM.
Notes: Overload protection. Protection against short-circuiting. Protection against polarity reversal. Rechargeable battery types Pb WET maintenance free, Pb AGM

Art./Ref.	Alimentazione/Voltage	Kw/Kw	Tensione nominale V/Nominal voltage V	Corrente carica efficace/Effective charging power	Corrente carica media/Average charging power	Capacità nominale/Rated capacity	Posizione carica/Charge position	Altezza mm/Height mm	Larghezza mm/Width mm	Profondità mm/Depth mm	Peso Kg/Weight Kg
38802	230 V - 50 hz	2,5/11 KW	12/24	105	70	35/800	4	700	470	320	28

CARICA BATTERIE COMPATTO PORTATILE

CHARGEUR DE BATTERIES
 PORTABLE BATTERY CHARGERS
 BATTERIELADE
 CARGADOR DE BATERIA



Note: Tipi di batterie ricaricabili: al Pb Wet con e senza manutenzione, Pb AGM. Protezione contro le inversioni di polarità. Protezione contro i corto circuiti alle pinze.
Notes: Rechargeable battery types Pb WET maintenance free, Pb AGM. Protection against polarity reversal. Protection against short-circuiting.

Art./Ref.	Alimentazione/Voltage	Kw/Kw	Tensione nominale V/Nominal voltage V	Corrente carica efficace/Effective charging power	Corrente carica media/Average charging power	Capacità nominale/Rated capacity	Posizione carica/Charge position	Altezza mm/Height mm	Larghezza mm/Width mm	Profondità mm/Depth mm	Peso Kg/Weight Kg
36902	230V-50hz	80W	12	6	4	20/90	1	95	225	160	1,5

CARICA BATTERIE CON AVVIAMENTO RAPIDO (PER LA CARICA DI ACCUMULATORI AL PIOMBO)

CHARGEUR DE BATTERIES AVEC DÉMARRAGE RAPIDE POUR LA CHARGE DE BATTERIES AU PLOMB

BATTERY CHARGER WITH RAPID STARTER FOR CHARGING LEAD ACCUMULATORS AND QUICK BOOSTING

BATTERIELADEGERÄT MIT SARTHILFEVORRICHTUNG, ZUM LADEN VON BLEIBATTERIEN UND SCHNELLSTARTEN

CARGADOR DE BATERIA CON ARRANQUE RÁPIDO PARA LA CARGA DE UN ACUMULADOR DE PLOMO



Note: Regolazione della corrente di carica. Protezione termostatica. Protezione contro i corto circuiti. Protezione contro le inversioni di polarità. / Tipi di batterie ricaricabili: al Pb Wet con e senza manutenzione, Pb AGM.

Notes: Adjustment of charging current. Thermostatic protection. Protection against short-circuiting. Rechargeable battery types Pb WET maintenance free, Pb AGM.

Art./Ref.	Alimentazione/Voltage	Kw/Kw	Tensione nominale V/Nominal voltage V	Corrente carica efficace/Effective charging power	Corrente carica media/Average charging power	Capacità nominale/Rated capacity	Posizione carica/Charge position	Altezza mm/Height mm	Larghezza mm/Width mm	Profondità mm/Depth mm	Peso Kg/Weight Kg
19195	230V-50hz	0,7/3,5KW	12/24	14	20	25/350	2	400	300	640	13,5
83804	230V 50hz	1,3/6	12/24	26	40	35/500	4	400	300	640	18

CARICA BATTERIE CON AVVIAMENTO RAPIDO (PER LA CARICA DI ACCUMULATORI AL PIOMBO/ELETTROLITO)

CHARGEUR DE BATTERIES DÉMARRAGE RAPIDE POUR ACCUMULATEURS AU PLOMBE/ELECTROLYTE

BATTERY CHARGER WITH RAPID STARTER FOR LEAD ACCUMULATORS/ELECTROLYTE AND QUICK BOOSTING

BATTERIELADEGERÄT MIT SCHNELLSTARTEN ZUM LADEN VON BLEI ELEKTROLYTBATTERIEN

CARGADOR DE BATERIA CON ARRANQUE RÁPIDO PARA LA CARGA DE UN ACUMULADOR DE PLOMO ELECTROLITO



Note: Regolazione della corrente di carica. Protezione termostatica. Protezione contro i corto circuiti. Protezione contro le inversioni di polarità. / Tipi di batterie ricaricabili: al Pb Wet con e senza manutenzione, Pb AGM.

Notes: Adjustment of charging current. Thermostatic protection. Protection against short-circuiting. Rechargeable battery types Pb WET maintenance free, Pb AGM.

Art./Ref.	Alimentazione/Voltage	Kw/Kw	Tensione nominale V/Nominal voltage V	Corrente carica efficace/Effective charging power	Corrente carica media/Average charging power	Capacità nominale/Rated capacity	Posizione carica/Charge position	Altezza mm/Height mm	Larghezza mm/Width mm	Profondità mm/Depth mm	Peso Kg/Weight Kg
19194	230V-50hz	0,5/3KW	12/24	20	13	20/300	2	160	340	300	11

CARICA BATTERIE (PER LA CARICA DI TUTTI I TIPI DI ACCUMULATORI AL PIOMBO/ELETTROLITO)

CHARGEUR DE BATTERIES POUR ACCUMULATEURS AU PLOMBE/ELECTROLYTE
 BATTERY CHARGER SUITABLE FOR LEAD ELECTROLYTE ACCUMULATORS
 BATTERIELADEGERÄT ZUM LADEN VON ELEKTROLYBATTERIEN
 CARGADOR DE BATERIA, PARA LA CARGA DE ACUMULADOR DE PLOMO ELECTROLITO



Note: Regolazione della corrente di carica. Protezione termostatica. Protezione contro i corto circuiti. Protezione contro le inversioni di polarità. Tipi di batterie ricaricabili: al Pb Wet con e senza manutenzione, Pb AGM

Notes: Adjustment of charging current. Thermostatic protection. Protection against short-circuiting. Protection against polarity reversal. Rechargeable battery types Pb WET maintenance free, Pb AGM

Art./Ref.	Posizione/ Position	Alimentazione/ Voltage	Kw/Kw	Tensione nominale V/Nominal voltage V	Corrente carica efficace/Effective charging power	Corrente carica media/Average charging power	Capacità nominale/Rated capacity	Posizione carica/Charge position	Altezza mm/Height mm	Larghezza mm/Width mm	Profondità mm/Depth mm	Peso Kg/Weight Kg
19192	1	230V-50hz	130W	12/24	9	6	15/140	2	270	200	190	4
19193	2	230V-50hz	600W	12/24	30	20	20/300	2	270	200	190	7,5

CARICA BATTERIE COMPATTO PORTATILE

CHARGEUR DE BATTERIES
 PORTABLE BATTERY CHARGERS
 BATTERIELADE
 CARGADOR DE BATERIA



Note: Tipi di batterie ricaricabili: al Pb Wet con e senza manutenzione, Pb AGM. Protezione contro le inversioni di polarità. Protezione contro i corto circuiti alle pinze.

Notes: Rechargeable battery types Pb WET maintenance free, Pb AGM. Protection against polarity reversal. Protection against short-circuiting

Art./Ref.	Alimentazione/Voltage	Kw/Kw	Tensione nominale V/Nominal voltage V	Capacità nominale/Rated capacity	Corrente carica efficace/Effective charging power	Corrente carica media/Average charging power	Posizione carica/Charge position	Altezza mm/Height mm	Profondità mm/Depth mm	Larghezza mm/Width mm	Peso Kg/Weight Kg
19191	230V-50hz	50W	6/12	15/60	4	2,5	1	95	160	225	1,3

TRECCIA DI MASSA

CABLES DE MASSE
EARTH CABLE
MASSEKABEL
CABLE DE TIERRA

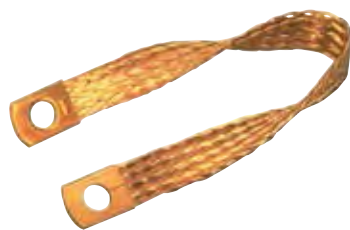

Note: Filo CU 0,20 mm rosso; Terminali da nastro CU stagnato

Notes: Red wire CU 0,20mm

Art./Ref.	Lunghezza mm/Lenght mm	Sezione/Section	Foro A/A hole	Foro B/B hole
00857	320 mm	25mm ²	10,5 mm	10,5 mm
26108	500 mm	50mm ²	12 mm	12 mm

TRECCIA DI MASSA CON MORSETTO BATTERIA

CABLES DE MASSE
EARTH CABLE WITH TERMINAL
MASSEKABEL
CABLE DE TIERRA CON BORNE BATERÍA



Art./Ref.	Polarità/Polarity	Sezione/Section	Lunghezza mm/Lenght mm	Dimensioni/Sizes	Note/Note
00858	Negativa	25 mm ²	400 mm	20X2.0 mm	Fissaggio: 10 mm/Fixing: 10 mm
19005	Negativa	35 mm ²	500 mm	30X3.0 mm	Fissaggio: 12 mm/Fixing: 12 mm
26109	Negativa	50 mm ²	500 mm	30X3,5 mm	Fissaggio: 12 mm/Fixing: 12 mm

MORSETTI BATTERIA

COLLIERS DE BATTERIE
BATTERY TERMINALS
BATTERIEKLEMMEN
BORNES BATERÍA



Art./Ref.	Sezione/Section	Polarità/Polarity	Note/Note
00725	25÷50 mm ²	Positivo	Ottone/Brass
00727	25÷50 mm ²	Negativo	Ottone/Brass

MORSETTI BATTERIA - TIPO PESANTE*ETAUX BATTERIE - TYPE LOURD**BATTERY TERMINALS - HEAVY TYPE**BATTERIEKLEMMEN - SCHWERE AUSFÜHRUNG**BORNES BATERÍA - TIPO PESADO*

Art./Ref.	Sezione/Section	Polarità/Polarity	Note/Note
19003	50 -70 -90 mm ²	Positivo	Ottone/Brass
19004	50 -70 -90 mm ²	Negativo	Ottone/Brass

MORSETTI BATTERIA - TIPO INDUSTRIALE*ETAUX DE BATTERIE - TYPE INDUSTRIEL**BATTERY TERMINALS - INDUSTRIAL TYPE**BATTERIEKLEMMEN - INDUSTRIELLE AUSFÜHRUNG**BORNES BATERÍA - TIPO INDUSTRIAL*

Art./Ref.	Sezione/Section	Polarità/Polarity	Diametro mm/Diameter mm	Note/Note
00456	16 ÷ 70 mm ²	Positivo	M 6	Ottone/Brass
00457	16 ÷ 70 mm ²	Negativo	M 6	Ottone/Brass
19006	16 ÷ 70 mm ²	Positivo	M 8	Ottone/Brass
19007	16 ÷ 70 mm ²	Negativo	M 8	Ottone/Brass

CAVI AVVIAMENTO CON PINZE*CABLES DE DEMARRAGE AVEC PINCES METAL**BOOSTER CABLES WITH METAL CLAMPS**STARTHILFEKABEL METALL ZANGEN MIT SCHIEFMAUL**CABLES DE ARRANQUE CON ALICATES*

Art./Ref.	Ampere/AMP	Lunghezza mm/Lenght mm	Sezione/Section	Note/Note
00443	120 A	2500 mm	25 mm ²	-
00376	400 A	3500 mm	35 mm ²	-
00937	400 A	3500 mm	35 mm ²	In valigetta di plastica/In plastic case
00938	500 A	5000 mm	50 mm ²	In valigetta di plastica/In plastic case

PINZE CARICA BATTERIE

COUPLE PINCES PORTE-COURANT (NOIR+ROUGE)

CHARGING CLIPS

PAAR KLEMMEN FÜR STARTHILFTEKABEL (SCHWARZ+ROT)

ALICATES PORTACORRIENTE (NEGRA+ROJA)



Art./Ref.	Ampere/AMP	Sezione/Section	Note/Note
00388	90 A	10÷25 mm ²	Red and Black
00399	120 A	10÷35 mm ²	Red and Black
00431	200 A	10÷35 mm ²	Red and Black
00432	300 A	10÷35 mm ²	Red and Black

CAVI BATTERIA

CABLES DE BATTERIE

BATTERY CABLES

BATTERIEKABEL

CABLE PARA BATERÍA

Note: Cavi batteria Coprimorsetto incluso

Notes: The terminal cover for battery cables is included

Art./Ref.	Lunghezza mm/Lenght mm	Sezione/Section	Note/Note
CF.0500.BD	500 mm	35 mm ²	Morsetto positivo e capocorda ad occhiello ø 10mm/Positive battery terminal, heavy wire terminal with eyelet ø 10mm
CF.1000.BD	1000 mm	35 mm ²	Morsetto positivo e capocorda ad occhiello ø 10mm/Positive battery terminal, heavy wire terminal with eyelet ø 10mm

CAPPUCCIO PROTEZIONE MORSETTI BATTERIA

CABOCHON COLLIERS DE BATTERIE

BATTERY TERMINALS COVER

SCHUTZKAPPE FÜR BATTERIEKLEMMEN

TAPA DE PROTECCIÓN BORNES BATERÍA

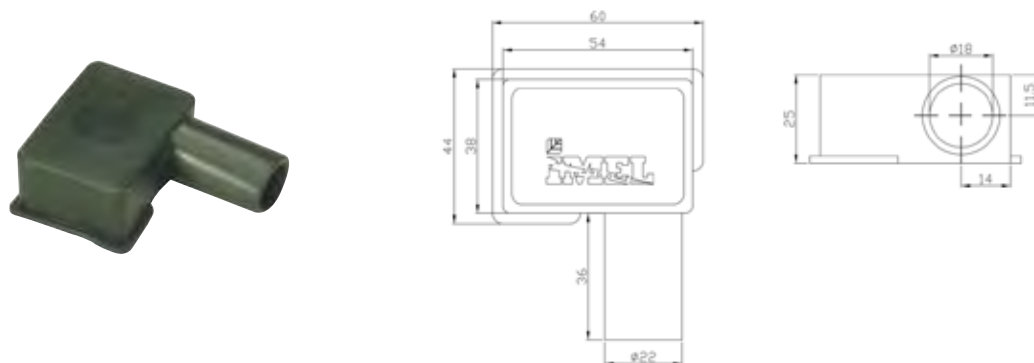

Art./Ref.	Polarità/Polarity	Tipo/Type	Lunghezza mm/Lenght mm	Note/Note	Brand	Rif. Orig./Orig. Ref.
00709	Positivo	Sx/Left	80 mm	PVC nero/black	FIAT	4062070
09424	Negativo	Dx/Right	80 mm	PVC nero/black	-	-

CAPPUCCI DI PROTEZIONE

CAPUCHON DE PROTECTION
PROTECTION CAP
SCHUTZKAPPEN
TAPAS DE PROTECCION



Art./Ref.	Foro A/A hole	Foro B/B hole	Lunghezza mm/Lenght mm	Note/Note
19588	Ø 15 mm	Ø 7,5 mm	41 mm	PVC nero/black
19589	Ø 19 mm	Ø 16 mm	56,5 mm	PVC nero/black

INTERRUTTORE STACCABATTERIA

COUPE BATTERIE UNIPOLAIRE
BATTERY MAIN SWITCH, SINGLE POLE
BATTERIETRENNSCHALTER, EINPOLIG
INTERRUPTOR DE BATERÍ A



Art./Ref.	Volt/Volt	Spunto/Start	Ampere/AMP	Note/Note
09181	12 / 24 V	Corrente di picco 2500 A 5"	Corrente max continua: 250A	IP 65; Temperatura d'impiego: -40°C ÷ +80°C

INTERRUTTORE STACCABATTERIA UNIPOLARE CON LEVA ESTRAIBILE

COUPE BATTERIE UNIPOLAIRE POIGNEE PLASTIQUE ENLEVABLE
BATTERY MAIN SWITCH, SINGLE POLE, WITH REMOVABLE HANDLE
BATTERIETRENNSCHALTER EINPOLING MIT ABZIEHBAREN BETÄTIGUNG GSHEBEL
INTERRUPTOR DE BATERÍA UNIPOLAR CON PALANCA EXTRAÍBLE



Art./Ref.	Volt/Volt	Spunto/Start	Ampere/AMP	Note/Note
09862	12 / 24V	Corrente di picco 2500 A 5"	Corrente maxc. continua 100 A	Contatti in rame, Dadi M8 acciaio zincato/ Copper contacts, M8 zinc plated steel

TESTER BATTERIA E ALTERNATORE

TESTER POUR BATTERIE ET ALTERNATEUR
 BATTERY & ALTERNATOR TESTER
 AKKO UND LICHTMACHINE TESTER
 PROBADOR BATERIA Y ALTERNATOR



Note: test batterie 12v- test alternatore 12v
 uso facile ed intuitivo
 durata della prova 15sec.
 effettua il test della batteria secondo norme en, din, iec, sae, jis
 adatto per batterie standard e con tecnologia al gel
 pinze a doppio contatto
 prova effettuata a bassa corrente, senza possibilita' di scintille o surriscaldamento
 per non danneggiare la centralina elettronica
 possibilità di lettura in 6 lingue

Notes: battery & alternator tester 12v
 simple and intuitive
 duration of the test 15sec.
 makes battery test according to en, din, iec, sae, jis
 suitable for batteries with standard and gel technology
 clamp double contact
 low current test performed without any possibility of sparks and overheating to
 avoid damaging the electronic control unit
 possibility of reading in 6 languages

Art./Ref.	Volt/Volt
84697	12

TEST DELLA BATTERIA

1. Accensione del tester. (Power on)
2. Collegamento delle pinze alla batteria. (Connect clamps to battery)
3. Selezione della lingua. (Language selection)
4. Lettura caratteristiche batteria. (Read battery characteristics)
5. Selezione della tensione nominale. (Select nominal voltage)
6. Selezione della tecnologia della batteria. (Select battery technology)
7. Test della batteria. (Battery test)
8. Risultato del test. (Test result)
9. Tensione della batteria, Potenza del carico e % della corrente erogata. (Battery voltage, Load power and % current output)

TEST DELL'ALTERNATORE

1. Accensione del tester. (Power on)
2. Collegamento delle pinze all'alternatore. (Connect clamps to alternator)
3. Selezione della lingua. (Language selection)
4. Avviare il motore ed accendere alcuni utilizzatori (es. fan, lavetto termico). (Start engine and turn on some consumers)
5. Selezione della tensione nominale. (Select nominal voltage)
6. Selezione della tecnologia dell'alternatore. (Select alternator technology)
7. Test dell'alternatore. (Alternator test)
8. Risultato del test. (Test result)
9. Tensione media al carico della batteria. (Average battery voltage under load)

MULTIMETRO MULTIFUNZIONE

MULTIMETER
 MULTIMETRE
 VIELFACHMESSGERAT
 MULTIMETROS



Note: multimetro cat III
 Eseguo le misure:
 -Tensione AC/DC fino a 600V
 -Test batterie 1,5-3-9v
Notes: Multimeter cat III
 Performs the measurements:
 -AC / DC voltage up to 600V
 Current up to 10Amp
 -Protected by internal fuse
 Test batteries 1,5-3-9V

Art./Ref.	Volt/Volt	Note/Note
84699	600	Multimetro digitale portatile / Handheld Digital Multimeter - Interruttore di accensione a slitta/ Power switch Slide - Display di misura 3 digit e 1/2 (1999 max) / Measurement Display 3 1/2 digit (1999 max) - Contenitore antiurto in gomma / Shockproof rubber - Misure di tensione continua e alternata / Measures DC and AC voltage - Misura di resistenza elettrica / Measurement of electrical resistance - Prova diodi / Diode test - Misura di corrente elettrica / Measurement of electric current - Prova batterie / Try batteries - Polarità automatica & Azzeramento lettura : automatico / Automatic polarity & zero reading: automatic - Indicazione di batteria scarica / Low battery indication - Leggero : solo 100 grammi / Light weight: only 100 grams - Tensioni fino a 600V, correnti fino a 200mA / Voltages up to 600V, current up to 200mA - Sicuro : omologato CE CAT III 6000V / Safe: Approved CE CAT III 6000V

ELETTROLITO PER BATTERIE PRONTO ALL'USO

ELECTROLYTE POUR BATTERIES PRET A L'USAGE

ACID FOR BATTERIES READY TO USE

ELEKTROLYT FÜR BATTERIEN (GEBRAUCHSFERTIG)

ELÉCTROLITO PARA BATERÍAS (LISTO POR EL USO)



Note: La chiusura con tappo e capsula termosaldada, garantisce la purezza dell'elettrolito, requisito fondamentale per l'efficienza della batteria.

Acido solforico 37% (32BE')

Omologazione: ONU UN4G/Y28/2015I/SSCCP/00234-0811/CPABS0140-13/BRIA12MP30

Notes: Closing by thermo-sealed cap guarantees acid pureness, basic requirement for good performance of the battery.

Sulfuric acid 37% (32 BE')

ONUUN4G/Y28/2015I/SSCCP/00234-0811/CPABS0140-13/BRIA12MP30 Approval

Art./Ref.	Dimensioni/Sizes
37332	1 lt
09565	5 lt

ACQUA TECNOLOGICA DEMINERALIZZATA

EAU DEIONISEE

DEIONIZED WATER

ENTIONISIERTES WASSER

AGUA DEIONIZADA



Note: Indicata per usi industriali, officine meccaniche, accumulatori, ferri da stiro, acquari, circuiti di raffreddamento, processi industriali

Notes: Suitable for industrial process, mechanical workshops, batteries, irons, aquarium, cooling circuits

Art./Ref.	Dimensioni/Sizes
15927	5 lt

1.8.2 Spie e Strumenti

Warning light and electrical instrument



Ricambi & accessori per macchine agricole

SPARE PARTS & ACCESSORIES FOR AGRICULTURAL MACHINE

Tutti gli articoli della presente sezione, prodotti da AMA SPA e/o da terzi per conto di AMA, sono adattabili ("non originali") alle marche indicate ai sensi di quanto previsto dal REG. CE n. 1400/2002. I diritti sui marchi citati appartengono ai legittimi proprietari ed il loro uso ha l'esclusiva finalità di consentire all'utilizzatore la comparazione dei diversi prodotti. All items of this section, manufactured by AMA SPA and/or any third party on behalf of AMA, are adaptable ("non-original") to the brands listed under the provisions of the REG. CE n. 1400/2002. The rights on the trademarks belong to their respective owners and their usage is only aimed to allow the user to compare different products.

CRUSCOTTO COMPLETO PER IMPIANTI LUCE DI MOTOAGRICOLE PROVviste DI BATTERIA

TABLEAU DE BORD POUR MACHINES AVEC BATTERIE

PANEL INSTRUMENTS FOR MACHINES WITH BATTERY

ARMATURENBRETTKASTEN FÜR MASCHINE MIT BATTERIE

TABLERO COMPLETO PARA EQUIPOS LUZ DE MÁQUINAS AGRÍCOLAS CON BATERIA

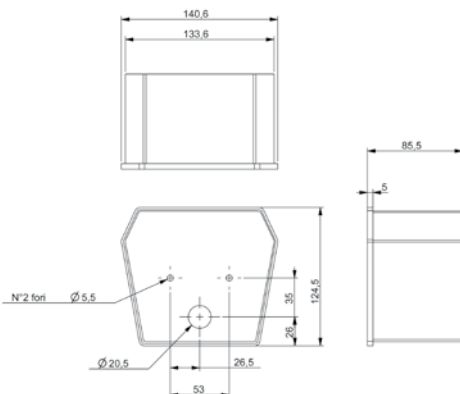

Art./Ref.	Descrizione/Description	Dimensioni/Sizes	Note/Note
02840	Art. 04158 quadro avviamento 0-1-2, Art. 00455 quadro luce 4 posizioni con clacson, Art. 01355 deviatore frecce, Art. 02853 spia verde, Art. 02854 spia rossa, Art.S14087 spia con vetro nero	140,6x124,5x85,5mm	Non cablato

CORPO CRUSCOTTO SERIGRAFATO

TABLEAU DE BORD

SERIGRAPHEd INSTRUMENT PANEL

ARMATURENBRETTKASTEN

CUERPO TEBLERO SERIGRAFADO

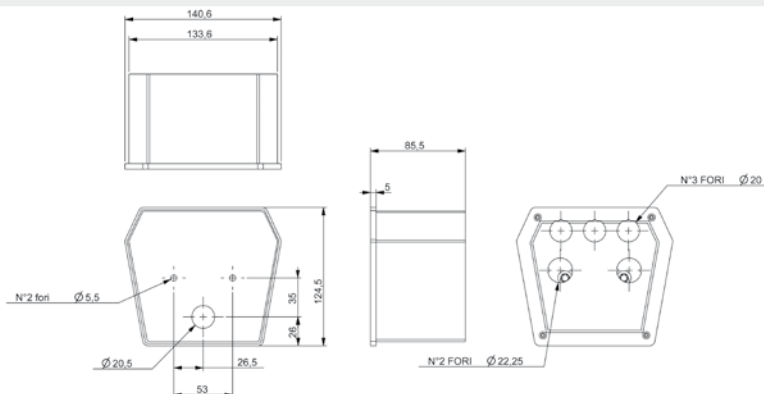

Art./Ref.	Dimensioni/Sizes
02821	140,6x124,5x85,5mm

TERMOMETRO TEMPERATURA ACQUA ELETTRICO 40°-120°

TERMOMETRE ELECTRIQUE EAU 40°-120°

WATER ELECTRONIC THERMOMETER 40°-120°

ELEKTRISCHE WASSERTHERMOMETER 40°-120°

TERMÓMETRO TEMPERATURA AGLIA ELÉCTRICO 40°-120°



Note: Retroilluminazione di colore bianco
 Connettore Minifit a 4 poli
 ISO7637-2 ISO 2575
 Art. IME.122 Cavo adattatore

Notes: White backlight
 MINIFIT connector
 ISO7637-2 ISO 2575
 Pn IME.122 cable

Art./Ref.	Volt/Volt	Dima mm/Dima	Grado di protezione/Protection grade
01914	12V	Ø 52,5	IP 65
09176	24	Ø 52,5	IP 65

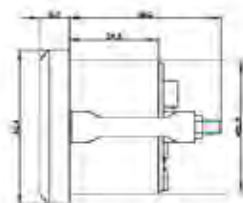

MANOMETRO PRESSIONE OLIO

MANOMETRE PRESSION HUILE
OIL PRESSURE MANOMETER
OELDRUCKMANOMETER
MANÓMETRO PRESIÓNÂ ACEITE



Art./Ref.	Filettatura/ Thread	Bar/Bar	Dima mm/ Dima	Grado di protezione/ Protection grade	Note/Note	Brand	Rif. Orig./Orig. Ref.
00621	1/8 Conico	0-8 bar	Ø52mm	IP65	Scatola in ferro zincato. Cornice in acciaio INOX./ Galvanized iron box. Stainless steel frame.	FIAT	4058426, 4058427, 4224156, 4240005, 79011228, 79028289
00628	8x1 mm	0-7 bar	Ø52mm	IP65	Attacco maschio M 8x0,75 mm./ Male connection M 8x0,75 mm.	FIAT	79028289
00660	3/8	0-7 bar	Ø52mm	IP65	Attacco femmina M 10x1 mm/ Female connection M 10x1 mm	MASSEY FERGUSON	1850377M96, 1853097M91, 506902M92
00676	10x1mm	0-7 bar	52 MM	IP65	Scatola in ferro zincato. Cornice in acciaio INOX./ Galvanized iron box. Stainless steel frame.	FIAT - SAME - CARRARO	2.70.19.0100, 4075531, 4217718, 4243842, 4927022, 79051149

INDICATORE ELETTRONICO DI CARICA BATTERIA

INDICATEUR ELECTRONIQUE DE CHARGE BATTERIE
ELECTRONIC BATTERY CHARGE INDICATOR
ELEKTRONISCHER ANZEIGER BETTERIELADUNG
INDICADOR ELECTRONICO DE CARGA BATERIA

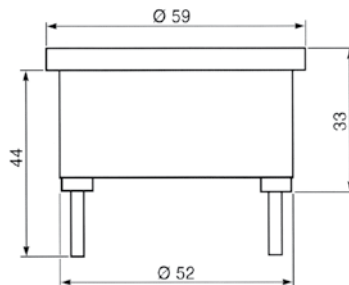

Art./Ref.	Volt/Volt
36506	48
36509	80

INDICATORI DI TENSIONE 12V Ø 52MM

VOLTMETRE Ø 52
VOLATGE GUAGE 12V Ø 52MM
STROMSTÄRKEMESSER Ø 52
VOLTÁMETRO Ø 52

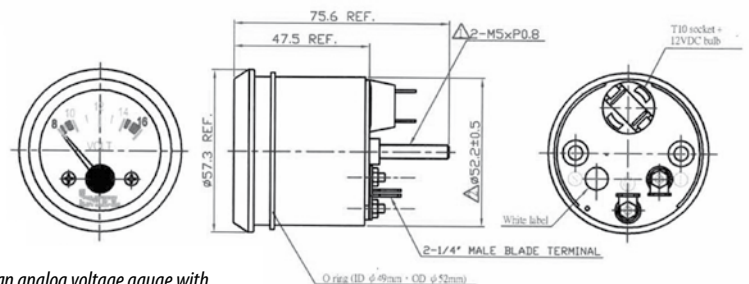

Note: E' un indicatore di tensione analogico con tecnologia stepper motor
Connettore tipo MINIFIT a 4 poli
Art. IME.122: cablaggio per connessione a faston incluso
EMC: ISO 7637-2 ISO 2575

Notes: The instrument is an analog voltage gauge with stepper motor technology
4-pole connector type Minifit
Pn IME.122: cable for connection to a socket included
EMC: ISO 7637-2 ISO 2575

Art./Ref.	Volt/Volt	Dima mm/Dima	Configurazioni/Configurazioni	Temperatura/Temperature
09170	8-16V	Ø 52 mm	Retroilluminato	-25°C; +85°C

INDICATORI LIVELLO CARBURANTE Ø 52

INDICATEUR NIVEAU CARBURANT Ø 52
 FUEL LEVEL INDICATOR Ø 52
 TANKANZEIGER Ø 52
 INDICADOR NIVEL CARBURANTE Ø 52

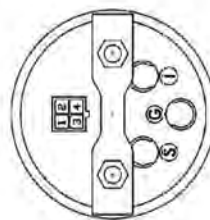
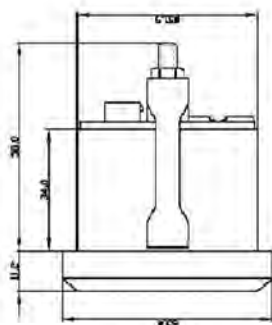

Note: IP65

Art. IME.122: cavo di collegamento
 EMC: ISO 7637-2 ISO 2575

Notes: IP65

Pn IME.122 cable
 EMC: ISO 7637-2 ISO 2575

Art./Ref.	Volt/Volt	Dima mm/Dima
09172	12	Ø 52
09173	24	Ø 52

CONTAORE ELETTRICI Ø 52

HORAMETRE ELECTRIQUE Ø 52
 ELECTRIC COUNTER Ø 52
 STUNDENZÄHLER Ø 52
 CUENTAHORAS ELÉCTRICO Ø 52

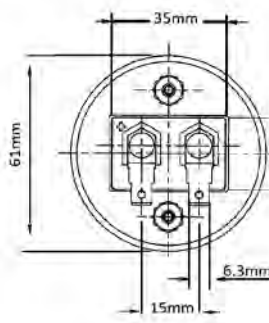
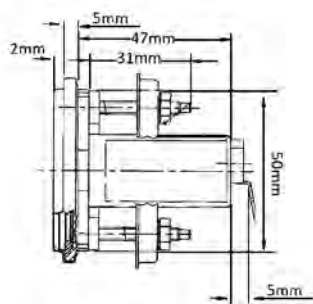

Art./Ref.	Volt/Volt	Dima mm/Dima	Accessorio/null
00444	12-60V	Ø 52,5	01880 - faston femmina 0,5-2 02581 - cappuccio

CONTAORE ELETTRONICO RETTANGOLARE

COMPTEUR ELECTRIQUE RECTANGULAIRE
 ELECTRICAL RECTANGULAR COUNTER
 ELEKTRONISCHR RECHTECKIGER ZÄHLER
 CONTADOR ELECTRONICO RETTANGULAR

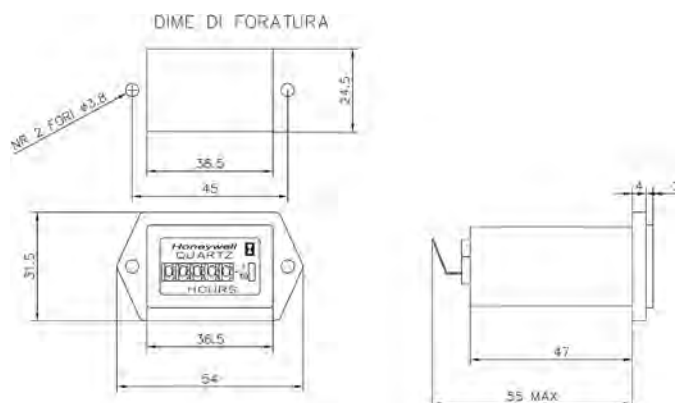

Art./Ref.	Volt/Volt	Accessorio/null
58595	10-32V	01880 - faston femmina 0,5-2 02581 - cappuccio

CONTAGIRI CON CONTAORE Ø 100 MM

COMPTOURS AVEC HORAMETRE Ø 100
 RP INDICATOR WITH HOUR METER
 DREHZAHLMESSER MIT STUNDENZÄHLER Ø 100
 CUENTARREVOLUCIONES CON CUENTAHCAS Ø 100



Note: Contagiri analogico con tecnologia stepper motor, dotato di contaore LCD, è programmabile tramite 2 pulsanti posti nel retro dello strumento
 1 linea can bus opzionale
 Connettore Molex Minifit jr 4 poli
 Art. IME.125: cavo 90,0cm per connessione incluso
 EMC: ISO 7637-2 ISO 2575

Notes: Analogue engine rpm indicator with stepper motor technology with an LCD hourmeter, the Rpm function is programmable by 2 pushbutton.
 1 can bus line (optional)
 Connector Molex Minifit jr 4 poles
 Pn IME.125: cable 90,0cm included
 EMC: ISO 7637-2 ISO 2575

Art./Ref.	Volt/Volt	Dima mm/Dima	Temperatura/Temperature	Grado di protezione/Protection grade	Configurazioni/Configurazioni
09174	10-32V	Ø 100,5	-20°C; + 85°C	IP65 frontale , retro IP30	Illuminazione quadrante bianco LED, Illuminazione LCD contaore LED ambra

CONTAGIRI ELETTRONICI CON CONTAORE Ø 80 MM

COMPTOURS ELECTRIQUE AVEC HORAMETRE LCD Ø 80 MM
 ELECTRICAL REVOLUTION COUNTER WITH COUNTER LCD Ø 80 MM
 ELEKTRONISCHER DREHZAHLMESSER MIT STUNDENZÄHLER LCD Ø 80 MM
 CUENTAVUELTAS ELECTRONICO CUENTAHCAS LCD Ø 80 MM

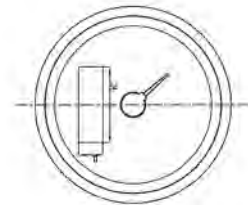
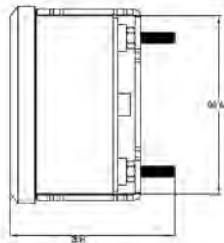
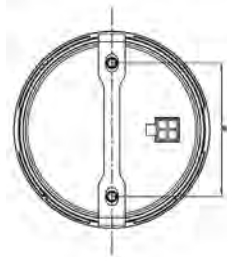

Note: Contagiri analogico con tecnologia stepper motor, dotato di contaore LCD, è programmabile tramite 2 pulsanti posti nel retro dello strumento
 1 linea can bus opzionale
 Connettore Molex Minifit jr 4 poli
 Art. IME.125: cavo 90,0cm per connessione incluso
 EMC: ISO 7637-2 ISO 2575

Notes: Analogue engine rpm indicator with stepper motor technology with an LCD hourmeter, the Rpm function is programmable by 2 pushbutton.
 1 can bus line (optional)
 Connector Molex Minifit jr 4 poles
 Pn IME.125: cable 90,0cm included
 EMC: ISO 7637-2 ISO 2575

Art./Ref.	Volt/Volt	Dima mm/Dima	Temperatura/Temperature	Grado di protezione/Protection grade	Configurazioni/Configurazioni
58597	10-32V	Ø 80,5	-20°C; + 85°C	IP65 frontale , retro IP30	Illuminazione quadrante bianco LED, Illuminazione LCD contaore LED ambra

SPIE

SVOYANTS
WARNING LIGHT
WARNLEUCHTE
SPIAS

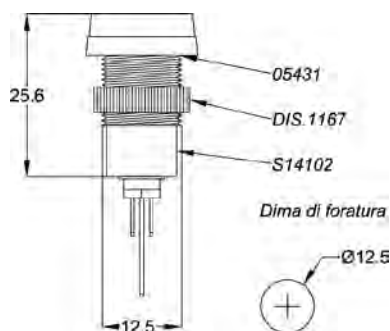

Art. L26049: Lampadina 12V / 12V Bulb
Art. L26050: Lampadina 24V / 24V Bulb

Art./Ref.	Funzione/Funzione	Colore/Color	Brand
S14151	Generatore/Gauge	Rosso/Red	A.M.A.
S14152	Pressione olio/Oil pressure	Rosso/Red	A.M.A.
S14153	Temperatura acqua/Water temperature	Rosso/Red	A.M.A.
S14154	Filtro olio/Oil filter	Rosso/Red	A.M.A.
S14155	Filtro aria/Air filter	Rosso/Red	A.M.A.
S14156	Parcheggio/Parking	Rosso/Red	A.M.A.
S14157	Riserva carburante/Low fuel	Arancio/Orange	A.M.A.
S14158	Candele/te/Glow plugs	Arancio/Orange	A.M.A.
S14159	Marcia lenta/Low speed	Arancio/Orange	A.M.A.
S14160	Marcia veloce/High speed	Arancio/Orange	A.M.A.
S14163	Luci anabbaglianti/Low beam	Verde/Green	A.M.A.
S14164	Marcia A-R/A-R gear	Verde/Green	A.M.A.
S14165	Abbaglianti/High beam	Blu/Blue	A.M.A.
S14166	Candele/te/Glow plugs	Arancio/Orange	A.M.A.
S14167	Livello olio trasmissione/Oil level entered	Rosso/Red	A.M.A.
S14168	Olio motore/Motor oil	Rosso/Red	A.M.A.
S14169	Filtro aria/Air filter	Rosso/Red	A.M.A.
S14170	Folle/"N" gear	Blu/Blue	A.M.A.
S14175	Neutra/Neutral	Arancio/Orange	A.M.A.
S14176	Freno motore/Motor break	Arancio/Orange	A.M.A.

SPIE SENZA LAMPADINA

VOYANTS SANS AMPOULE
 WARNING LIGHTS WITHOUT BULB
 DIE KONTROLLAMPEN SIND NICHT KOMPLETT MIT GLUHBIRNEN
 ESPÍAS SIN LAMPARILLA

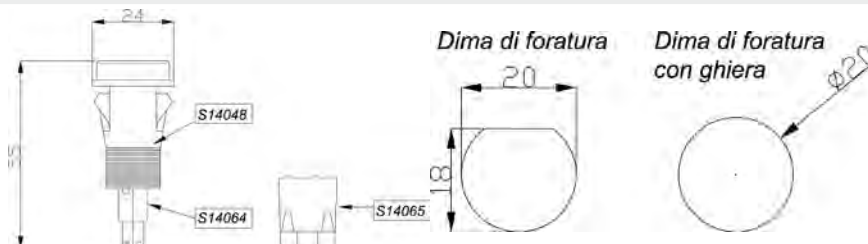

Note: Art. 00398 lampadina 12V 3W (T10)
 Art. L26016.0 lampadina 24V 3W (T10)

Notes: Pn 00398 12V 3W (T10)
 Pn L26016.0 24V 3W (T10)

Art./Ref.	Funzione/Funzione	Colore/Color
S14024	Neutra/Neutral	Giallo/Yellow
02843	Neutra/Neutral	Verde/Green
02844	Neutra/Neutral	Rosso/Red
02855	Neutra/Neutral	Blu/Blue
S14044	Tappo	Neutro
02853	Frecce/blinking	Verde/Green
08067	Luci Pos. lights	Verde/Green
S14006	Doppia trazione	Giallo/Yellow
S14042	Marcia lenta	Giallo/Yellow
58575	Marcia veloce/fast gear	Giallo/Yellow
08069	Riserva carburante/safety fuel	Giallo/Yellow
08083	Candelette/glow	Giallo/Yellow
02854	Carica batteria/battery	Rosso/Red
08060	Freno a mano/hand brake	Rosso/Red
08065	Pressione olio/oil pressure	Rosso/Red
08066	Temperatura acqua/water temperature	Rosso/Red
S14033	Avaria fren	Rosso/Red
S14004	Intasamento filtro aria	Rosso/Red
08068	Luci abbaglianti/high lights	Blu/Blue
08084	lampada rotante/beacon	Blu/Blue
S14019	Temperatura olio meccanico	Rosso/Red

INTERRUTTORI COMANDO SPIA OLIO

MANOCONTACTS D'HUILE
 OIL PRESSURE WARNING LIGHT SWITCHES
 ÖLDRUCKKONTROLLSCHALTER
 INTERRUPTORES MANDO ESPÍA ACEITE



Art./Ref.	Chiave/Key	Filettatura/Thread	Bar/Bar	Brand	Applicazione/Application	Rif. Orig./Orig. Ref.
03695	22	M12x1,5	0,20/0,50	LOMBARDINI	911	6745.014, 674505, 90406745031
03696	21	M12x1,5	0,20/0,50	SLANZI - LOMBARDINI	-	2760.6745.030, 6745.042
03697	22	1/8-27 NPT	0,40/0,60	LANDINI - MASSEY FERGUSON	FRUTTETI 560 F/L: 5560, FRUTTETI 560 F/L: 6060, FRUTTETI 560 F/L: 6560, FRUTTETI 560 F/L: 7560, FRUTTETI 560 F/L: 8560, SERIE/SERIES 200, SERIE/SERIES 600	1877721M92, 3599307M91
03698	22	M12x1,75	1,20/1,70	BOSCH	-	0 344 101 077
03740	22	M12x1,5	0,20/0,60	FIAT	-	4151243, 4998770, 4998771, 5107603, 5160694

TRASMETTITORE PRESSIONE OLIO

TRANSMETTEUR DE PRESSION D'HUILE
OIL PRESSURE SENDER
OLDRUCK IMPULSEGEBER
TRASMISOR PRESIÓN ACEITE



Art./Ref.	Chiave/Key	Filettatura/Thread	Bar/Bar	Volt/Volt	Brand	Applicazione/Application	Rif. Orig./Orig. Ref.
03745	19	M14x1,5	0.8	12	VEGLIA-B - A.M.A.	01915	064.5107.990.1

QUADRO LUCE 4 POSIZIONI CON CHIAVE DISINNESTABILE IN TUTTE LE POSIZIONI

CONTACTEUR 4 POSITIONS CLÉ DÉTACHABLE DANS TOUTE POSITION
LIGHT SWITCH - KEY TO AWAY IN ALL OF THE 4 POSITIONS
LICHTSCHALTER 4 POSITIONEN SCHLÜSSEL AUSZIEHBAR IN JEDER POSITION
SELECTOR DE LUCES CON 4 POSICIONES Y LLAVE DESEMBRAGABLE ENTODAS L

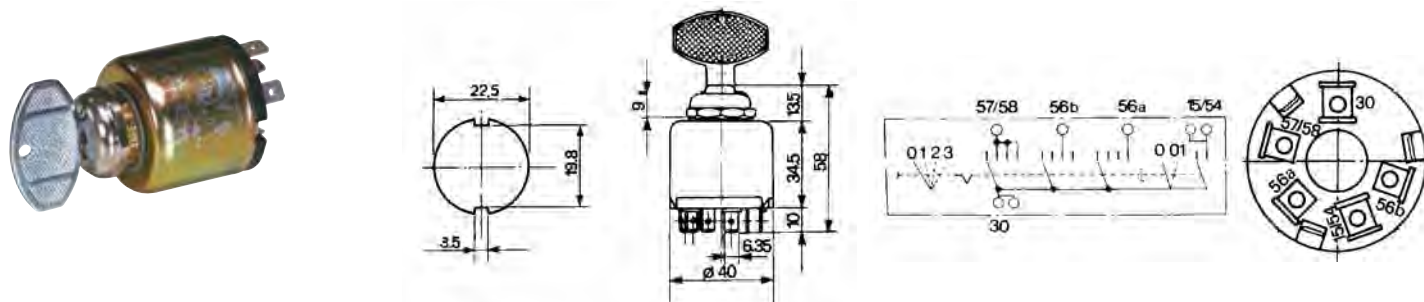

Note: Cobo 23.100.000.11 Notes: Cobo 23.100.000.11

Art./Ref.	Pos.	Chiave/Key	Funzione/Funzione	Carico max 12Volt/ Carico max 12Volt	Brand	Ricambio/ Replacement	Rif. Orig./ Orig. Ref.
00413	4 Posizioni: 0 - 1 - 2 - 3	Innestabile e disinnestabile in tutte le posizioni	0 disinnestata-off: -0 innestata-on: ser- vizi 1 disinnestata-off: luci di posizione 1 innestata-on: servizi 2 disinnesta- off: luci di posizione/anabaglianti 2 innestata-on: servizi	15A+10A+10A	SAME LAMBORGHINI HURLIMANN - GOLDONI - A.M.A. - PASQUALI	00542 - chiave om / om type key to suit 00413 switch	30155, 996.406.0, 2.7409.010.0, 2.7410.001.0, 2.7439.501.0

QUADRO LUCE 4 POSIZIONI CON AVVISATORE ACUSTICO A PULSANTE IN TUTTE LE POSIZIONI

CONTACTEUR 4 POSITIONS AVEC AVERTISSEUR SONORE
LIGHT SWITCH 4 STAGES WITH HORN BUTTON
LICHTSCHALTER 4 RASTSTELLUNGEN MIT DRUCKKNOPF FÜR HUPE
SELECTOR DE LUCES CON 4 POSICIONES Y AVISADOR ACÚSTICO CON BOTÓN EN TODAS LAS POSICIONES

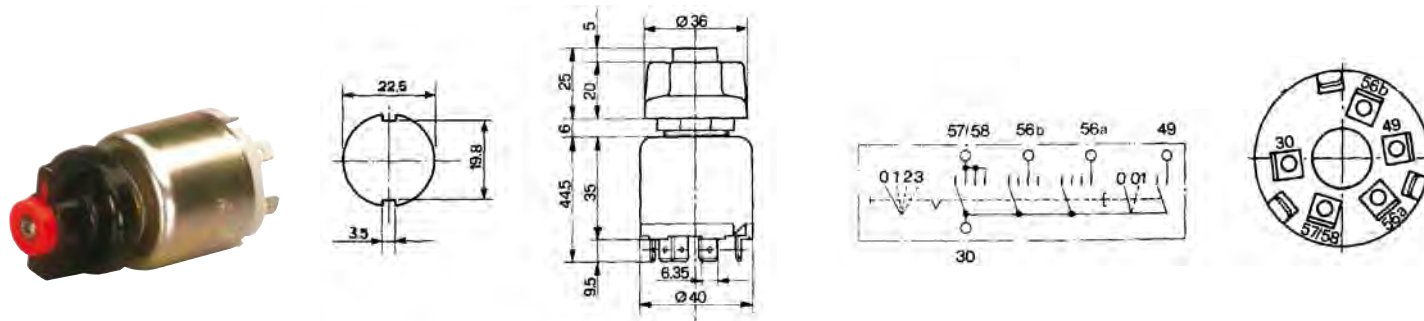

Art./Ref.	Pos.	Funzione/Funzione	Dima mm/Dima	Brand	Applicazione/Application	Rif. Orig./Orig. Ref.
00455	4 Posizioni: 0 - 1 - 2 - 3 e clacson	Posizione 0: - Posizione 1: luci di posizione Posizione 2: luci di posizione/anabaglianti- Posizione 3: Luce di posizione/abbaglianti	40 mm	SAME LAMBORGHINI HURLIMANN - LANDINI - FIAT - MASSEY FERGUSON	5500, 5840, 6500, 6840, 7500, 8500, CINGOLATI C: C4500, CINGOLATI C: C5500, CINGOLATI C: C6500, CINGO- LATI C: C7800	44901792, 1825360M91, 2.7409.030.0

QUADRO LUCE 4 POSIZIONI CON AVVISATORE ACUSTICO A PULSANTE IN TUTTE LE POSIZIONI

CONTACTEUR 4 POSITIONS AVEC AVERTISSEUR SONORE

LIGHT SWITCH 4 STAGES WITH HORN BUTTON

LICHTSCHALTER 4 RASTSTELLUNGEN MIT DRUCKKNOPF FÜR HUPE

SELECTOR DE LUCES CON 4 POSICIONES Y AVISADOR ACÚSTICO CON BOTÓN EN TODAS LAS POSICIONES

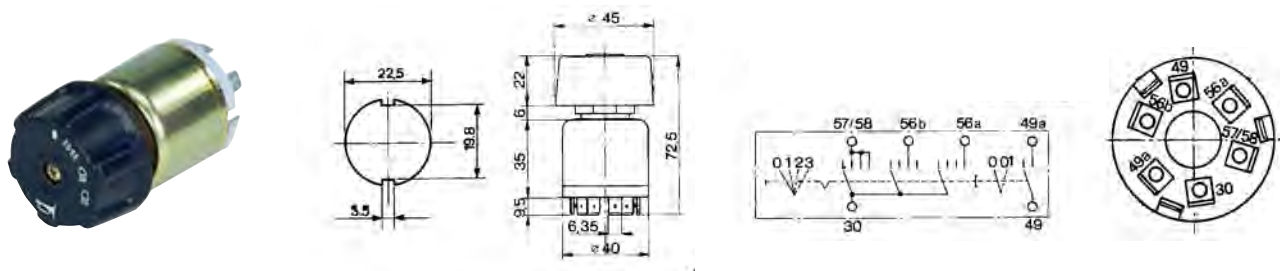

Art./Ref.	Pos.	Funzione/Funzione	Dima mm/Dima	Brand	Rif. Orig./Orig. Ref.
00414	4 Posizioni: 0-1-2-3 e clacson	Posizione 0: -Posizione 1: luce di posizione Posizione 2: luce di posizione/ anabbaglianti Posizione 3: luce di posizione/abbaglianti	40 mm	SAME LAMBORGHINI HURLIMANN - FIAT	4998107, 5132021, SERIE 66, 2.7409.050.0, 2.7409.500.0

QUADRO LUCE 6 POSIZIONI CON LUCE PARCHEGGIO PER TRATTORI FIAT (TIPO CLTB)

CONTACTEUR 6 POSITIONS AVEC FEUX POSITION POUR TRACTEURS FIAT (CLTB)

LIGHT SWITCH WITH PARKING LIGHT - 6 POSITIONS - FOR FIAT TRACTORS (CLTB)

LICHTSCHALTER MIT BREMSLICHT - 6 POSITIONEN - FÜR FIAT SCHLEPPER (CLTB)

SELECTOR DE LUCES 6 POSICIONES CON LUX DE APARCAMIENTO PARA TRACTORES FIAT (CLTB)

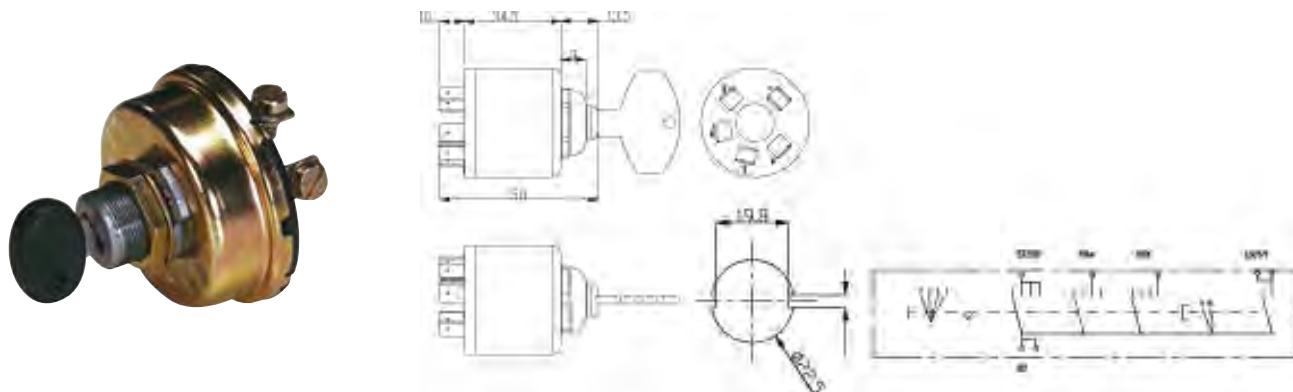

Art./Ref.	Chiave/Key	Brand	Rif. Orig./Orig. Ref.
00453	545	FIAT	4158641, 5118433

BLOCCETTO CHIAVI 2 POSIZIONI (CHIUSO - APERTO)

COMMUTATEUR 2 FONCTIONS (FERMÉ - OUVERT)

2 FUNCTION SWITCH (OPEN - CLOSED)

2 RASTUNGEN SCHALTER (OFFEN - GESCHLOSSEN)

COMUTADOR - 2 POSICIONES (CERRADO - ABIERTO)



Note: Chiave disinnestabile in posizione OFF

Notes: Key to away in OFF position

Art./Ref.	Pos.	Funzione/Funzione	Carico max 12Volt/Carico max 12Volt
04058	2 Posizioni: 0 - 1	Posizione 0: servizi Posizione 2: marcia	Posizione 1: 10A

QUADRO AVVIAMENTO ADATTABILE A BOSCH

CONTACTEUR "BOSCH"

START KEY SWITCHER BOSCH

STARTSCHALTER BOSCH

SELECTOR DE ARRQUE BOSCH

Note: Art. Q13043.P chiave
Disinnestabile in posizione 0

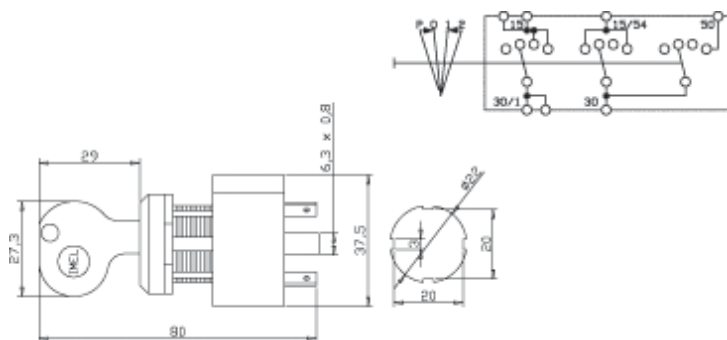
Notes: Pn Q13043.1 key
Key to away in 0 position

Art./Ref.	Pos.	Funzione/Funzione	Carico max 12Volt/Carico max 12Volt
12333	3 Posizioni. 0 - 1 - 2	Posizione 0: servizi Posizione 1: marcia Posizione 2: avviamento	Posizione 1: 12,5A Posizione 2: 12A

QUADRO AVVIAMENTO 4 POSIZIONI

CONTACTEUR STANDARD

SWITCH

STARTSCHALTER

SELECTOR DE ARRQUE STANDARD

Note: Art. 00546 chiave
Disinnestabile in posizione 0

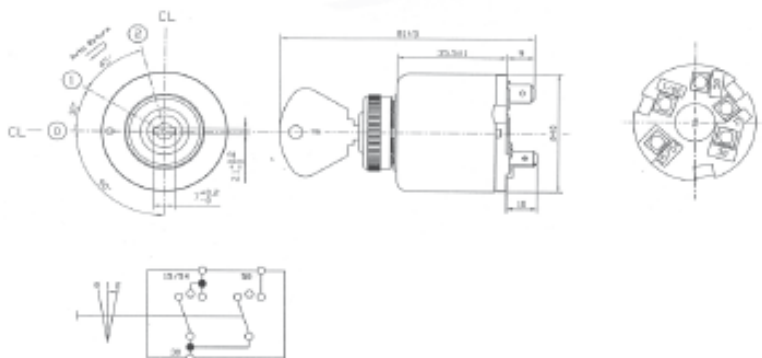
Notes: Pn 00546: key
Key to away in 0 position

Art./Ref.	Pos.	Funzione/Funzione	Carico max 12Volt/Carico max 12Volt
04158	4 Posizioni: P-0-1-2	Posizione P: servizi Posizione 0: servizi Posizione 1: marcia Posizione 2: avviamento	Posizione 1: 20A Posizione 2: 50A

QUADRO AVVIAMENTO 4 POSIZIONI

CONTACTEUR 4 POSITIONS

SWITCH 4 POSITIONS

STARTSCHALTER 4 POSITIONEN

SELECTOR DE ARRQUE CON 4 POSICIONES

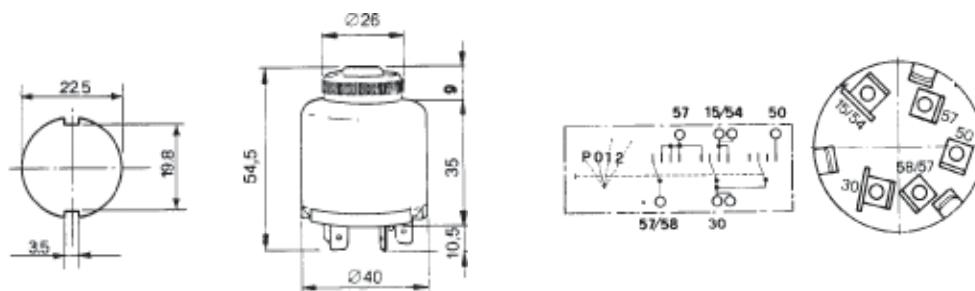

Note: Cobo 14.159.000
Art. 00546: chiave

Notes: Pn 00546: key
Cobo 14.159.000

Art./Ref.	Pos.	Funzione/Funzione	Chiave/Key	Dima mm/Dima	Brand	Rif. Orig./Orig. Ref.
01396	4 Posizioni: P-0-1-2	Posizione P: luci idi posizione Posizione 0: luci fari Posizione 1: Luci fari/marcia Posizione 2: luci fari/marcia/avviamento	Estraibile solo nella posizione P-0	22,5 mm	FIAT	4998108, 5112124, 5123727, 5146155

QUADRO AVVIAMENTO CON PARCHEGGIO E PRERISCALDO

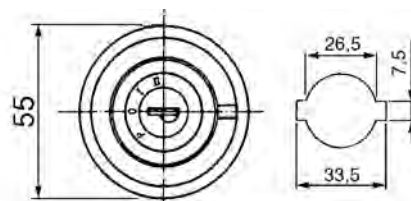
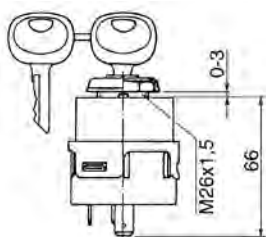
DEMARREUR AVEC PARCKING ET PRE-CHAUFFAGE
 KEY STARTING SWICH WITH PARKING LIGHTS AND PREHEATING
 ANLASSSCHALTER MIT PARK UND VORGLÜH
 CUADRO DE ARRANQUE CON APARCAMIENTO Y PRECALENTADO



chiave estraibile solo in "0"

Art./Ref.	Chiave/Key	Note/Note
57685	57686	Chiave estraibile solo nella posizione "0"/Key removable only in "0" position

QUADRO AVVIAMENTO 4 POSIZIONI CON LUCI PARCHEGGIO

CONTACTEUR 4 POSITIONS AVEC FEUX PARKING
 SWITCH 4 POSITIONS
 STARTSCHALTER 4 POSITIONEN
 SELECTOR DE ARRQUE CON 4 POSICIONES CON LUCES DE APARCAMIENTO

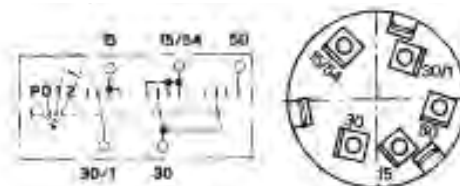
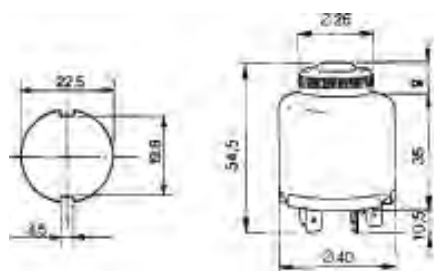

Note: Art. 00546 chiave
 Disinnestabile nella posizione 0 e P

Notes: Pn 00546 key
 Key to away in 0 and P position

Art./Ref.	Pos.	Funzione/Funzione	Carico max 12Volt/Carico max 12Volt	Brand	Rif. Orig./Orig. Ref.
00769	4 Posizioni: P - 0 - 1 - 2	Posione P : luce parcheggio Posizione 0: servizi Posizione 1: marcia Posizione 2: avviamento	Posizione P: 20A Posizione 1: 20A Posizione 2: 50A	SAME LAMBORGHINI HURLIMANN	2.7409.520.0, 2.7659.005.0

QUADRO AVVIAMENTO 4 POSIZIONI CON PRERISCALDO

CONTACTEUR 4 POSITIONS AVEC PRÉCHAUFFAGE
 SWITCH 4 POSITIONS WITH PRE-HEATING
 STARTSCHALTER 4 POSITIONEN MIT ERWÄRMUNG
 SELECTOR DE ARRQUE CON 4 POSICIONES CON PRECALENTAMIENTO

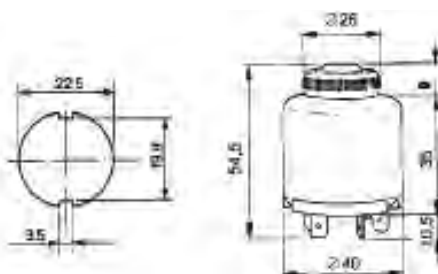

Note: Art. 00544 chiave
 disinnestabile in posizione 0 e P

Notes: Pn 00546 key
 Key to away in 0 and P postion

Art./Ref.	Pos.	Funzione/Funzione	Carico max 12Volt/Carico max 12Volt	Brand	Rif. Orig./Orig. Ref.
01397	4 Posizioni: P - 0 - 1 - 2	Posizione P: preriscaldamento Posizione 0: servizi Posizione 1: marcia Posizione 2: avviamento	Posizione P: 25A Posizione 1: 20A Posizione 2: 50A	SAME LAMBORGHINI HURLIMANN - FIAT	44901424, 9955994, 2.7659.006.0/01

INTERRUTTORE A PULSANTE PER CONSENSO AVVIAMENTO

BOUTON DE SÉCURITÉ
SAFETY PUSH BUTTON SWITCH
SICHERHEITSDRUCKSCHALTER KNOPESCHALTER
EMPUJE DE SEGURIDAD BOTTON

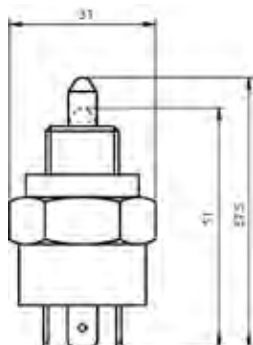

Note: IP66
Art. 01880: faston femmina 0,5-2mm
Art. 02581: cappuccio interno coprifaston
COBO 17.122.000.18

Notes: IP66
Pn 01880: faston 0,5-2mm
Pn 02581: cap
COBO 17.122.000.18

Art./Ref.	Carico max 12Volt/Carico max 12Volt	Carico max 24Volt/24Volt max load	Filettatura/Thread
I15010	45A induttivi a corrente max continua; 30A corrente di picco 5"	20A induttivi a corrente max continua; 20A corrente di picco 5"	M16x1,5

CHIAVE QUADRO LUCE FIAT

CLÉ POUR COMMUTATEUR FIAT
FIAT SWITCH KEY
FIAT SCHLÜSSEL
LLAVE SELECTOR DE LUCES FIAT



Art./Ref.	Brand	Rif. Orig./Orig. Ref.
00545	FIAT	9918786

CHIAVE QUADRO AVVIAMENTO FIAT MOD. 780-880

CLÉ POUR COMMUTATEUR FIAT 780-880
FIAT SWITCH 780-880 KEY
SCHLÜSSEL FIAT 780-880
LLAVE SELECTOR DE ARRANQUE FIAT



Art./Ref.	Chiave/Key	Brand	Rif. Orig./Orig. Ref.
00546	546	FIAT - FORD	5112713, 5170782, 5112713

CHIAVE PER QUADRO AVVIAMENTO

CLÉ POUR DEMARREUR
SWITCH KEY
SCHLÜSSEL FÜR ANLASSSCHALTER
LAVE PARA CUADRO DE ARRANQUE



Art./Ref.	Specifiche/Specifications
57686	Per quadro avviamento 57685

PULSANTE DI MASSA

BOUTON CHROMÉ POUR MASSE
EARTH PUSH-BUTTON
VERCHROMTER ABSTELLSCHALTER
INTERRUPTOR DE STOP REVESTIDO DE CROMO



Art./Ref.	Volt/Volt	Carico max 12Volt/Carico max 12Volt	Specifiche/Specifications
02093	12V	6A	Cromato, uscite serrafili

PULSANTE AVVIAMENTO

BOUTON DÉMARREUR
STARTER BUTTON
ANLASSKNOPF
BOTÓN ARRANQUE

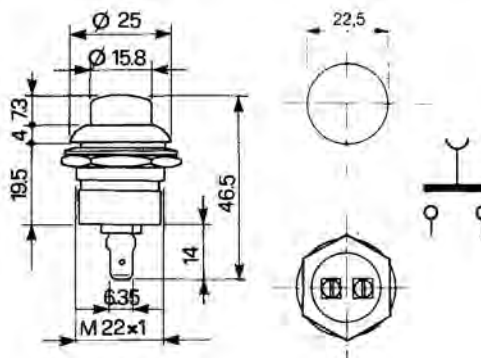

Art./Ref.	Grado di protezione/Protection grade
00083	IP40

CAPPUCCI

BOUCHONS
CAPS
SCHUTZKAPPEN
CAPUCHONES

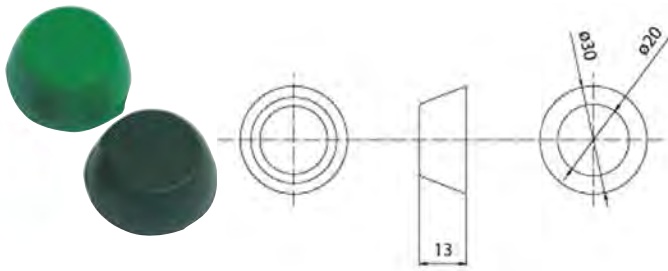

Art./Ref.
58582

INTERRUTTORE A PULSANTE PER AVVISATORE ACUSTICO

POUSSOIR CLAXON
HORN BUTTON
SCHALTER PIEPSE
PULSANTE AVISADOR ACUSTICO

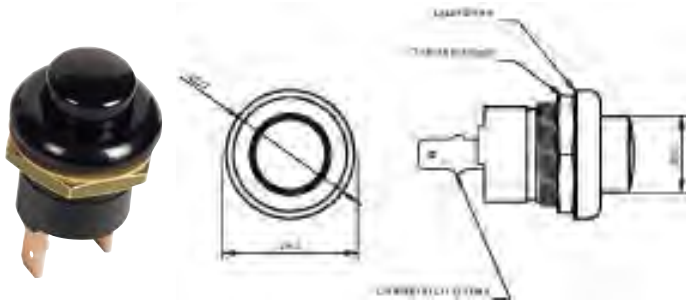

Note: COBO 17.134.000 Notes: COBO 17.134.000

Art./Ref.	Dima mm	Carico max 12Volt/ Carico max 12Volt	Carico max 24Volt/ 24Volt max load	Grado di protezione/ Protection grade
59703	22	25A resistivi corrente max continua ; 30A corrente di picco 5"	15A corrente max continua , 20A corrente di picco 5"	IP40

PULSANTE AVVISATORE ACUSTICO

BOUTON AVERTISSEUR SONORE
BUTTON FOR HORN
DRUCKKNOPFHUPE
BOTÓN AVISADOR ACÚSTICO



Art./Ref.	Grado di protezione/Protection grade
00459	IP64

INTERRUTTORI MECCANICI LUCE STOP NO

INTERRUPTEUR, STOP STANDARD
MECHANICAL NO BRAKE LIGHT SWITCHES
STOP - SCHALTER STANDARD
CONTACTEURS MECANIQUES DE FEUX STOP

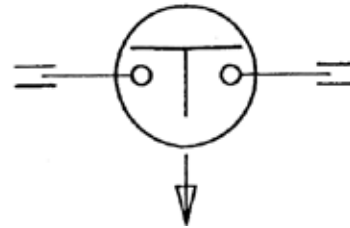

Art./Ref.	Chiave/Key	Filettatura/Thread
02429	19	Cilindrica M12 x1,25

INTERRUTTORI STOP

INTERRUPTEUR STOP
STOP SWITCHES
STOP-SCHALTER
INTERRUPTORES STOP



SCHEMA A RIPOSO
Art. 03956

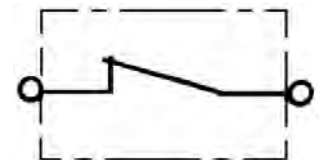

1

2

Art./Ref.	Pos.	Funzione/ Funzione	Note/ Note	Brand	Rif. Orig./ Orig. Ref.
03956	1	Posizione a riposo disinserito/ Reset position disconnected	Con molla/ With spring	FIAT	5121786, 5152966
03957	2	Posizione a riposo inserito/ Reset position connected	Con molla/ With spring	FIAT	4954118

INTERRUTTORE STOP IDRAULICO

INTERRUPTEUR STOP HYDRAULIQUE
HYDRAULIC STOP SWITCH
STOP - SCHALTER
INTERRUPTOR HIDRÁULICO STOP

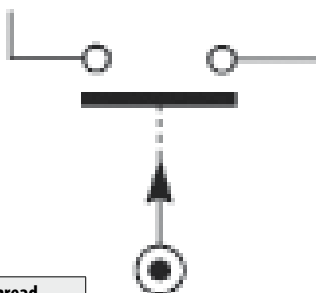
SCHEMA A RIPOSO

Art./Ref.	Chiave/Key	Filettatura/Thread
09180	22	10 x 1 Conico

INTERRUTTORE A PULSANTE ADATTABILI A FIAT

INTERRUPTEUR
SWITCHE
SCHALTER
INTERRUPTORE

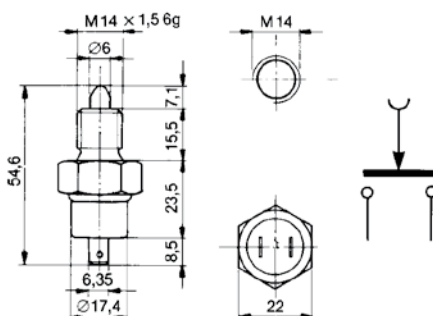

Note: COBO 17.120.000.18

Notes: COBO 17.120.000.18

Art./Ref.	Filettatura/Thread	Carico max 12Volt/Carico max 12Volt	Carico max 24Volt/24Volt max load	Grado di protezione/Protection grade
26948	M14X1,5 G	8A resistivi corrente max continua ; 30A corrente di picco 5"	4A resistivi corrente max continua; 20A corrente di picco 5"	IP 67

INTERRUTTORI MECCANICI LUCE STOP

INTERRUPTEURS STOP AVEC FRETTE EXT. FILETÉE
MECHANICAL BRAKE LIGHT SWITCHES
STOP-SCHALTER MIT GEWINDE
CONTACTEURS MECANIQUES DE FEUX STOP

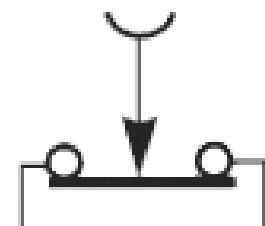
SCHEMA A RIPOSO

Art./Ref.	Chiave/Key	Filettatura/Thread	Altezza mm/Height mm
05523	19	Cilindrica M12 x 1,5	53
05590	19	Cilindrica M12 x 1,5	75

DEVIATORE A SCATTO RAPIDO

COMMUTATEUR AVEC DECLIC RAPIDE
SNAP-ACTION SWITCH
AUGENBLICKSCHALTER
DESVIADOR CON RESORTE RÁPIDO

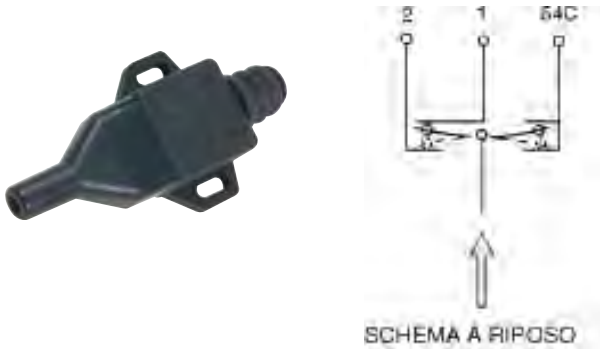

Note: Cappuccio protettivo incluso COBO 15.110.000 Notes: Protection cup included COBO 15.110.000

Art./Ref.	Volt/Volt	Grado di protezione/Protection grade	Brand	Rif. Orig./Orig. Ref.
01121	12	IP67	SAME LAMBORGHINI HURLIMANN - FIAT - FORD	340480431, 83952126, 2.7649.050.0/10

DEVIATORE PER INDICATORI D'ARRESTO

COMMUTATEUR AVEC DECLIC RAPIDE POUR INDICATEUR D'ARRET
SNAP-ACTION SWITCH FOR BRAKE LIGHTS
AUGENBLICKSCHALTER FUER ANHALTANZEIGER
DESVIADOR CON RESORTE RÁPIDO PARA INDICADORES DE PARADA

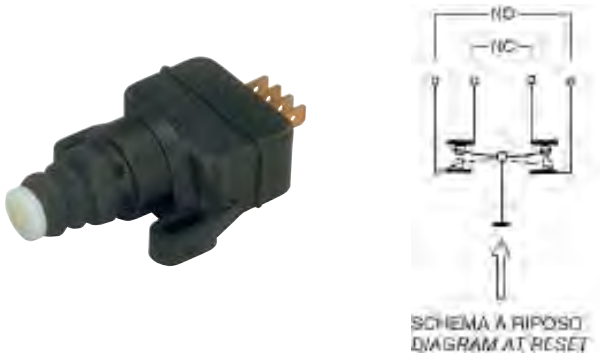

Note: Cappuccio di protezione incluso COBO 15.117.000 Notes: Protection cup included COBO 15.117.000

Art./Ref.	Volt/Volt	Grado di protezione/Protection grade	Brand	Ricambio/Replacement	Rif. Orig./Orig. Ref.
09863	12	IP 67	SAME LAMBORGHINI HURLIMANN - LANDINI - FIAT - PERKINS - A.M.A. - NEW HOLLAND - FORD	09864 - CAPPUCIO PER INTERRUPT. STOP / CAPPUCIO PER INTERRUPT. STOP	321564850, 47132449, 5101414, 5163618, 83961542, 3532018M91, 3667775, 83961542, 2.7659.097.0

INTERRUTTORI Ø30 PNEUTRON

INTERRUPTEURS Ø30 PNEUTRON
Ø30 PNEUTRON SWITCH RANGE
Ø30 PNEUTRON SCHALTER
INTERRUPTORES Ø30 PNEUTRON



SCHEMA 2

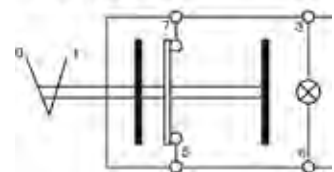

Note: Art. I36104 Blocchetto Notes: Art. I36104 Blocchetto

Art./Ref.	Funzione/Funzione	Volt/Volt	Grado di protezione/Protection grade	Note/Note	Schema/Schema
I36006	Emergenza/HAZARDa	12	IP66	20 AMP	1
I36007	Lampada rotante/BEACON	12	IP66	20 AMP	2

INTERRUTTORI BASCULANTI 12 V

INTERRUPTEUR A BASCULE 12 V
ROCKER SWITCHES 12 V
KIPPSCHALTER 12 V
INTERRUPTORES 12 V

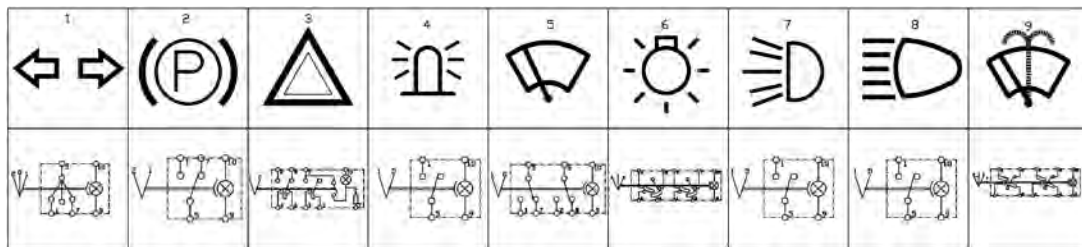

Art./Ref.	Pos.	Funzione/Funzione	Colore/Color
59058	1	Indicatore di direzione	Verde/Green
59059	2	Freno a mano attivo	Rosso/Red
59060	3	Emergenza	Rosso/Red
59061	4	Lampada rotante	Giallo/Yellow
59062	5	Tergicristalli	Verde/Green
59064	6	Luci posizione	Verde/Green
59065	7	Luci anabbaglianti	Verde/Green
59066	8	Luci abbaglianti	Blu/Blue
59069	9	Tergi e lava cristalli	Verde/Green

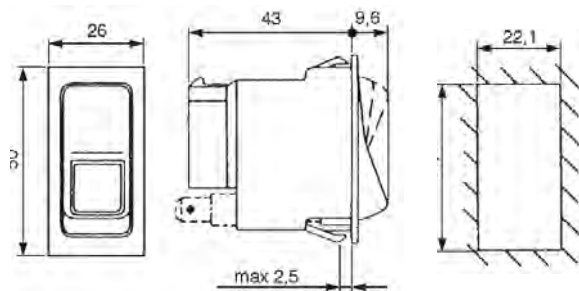
INTERRUTTORI

INTERRUPTEURS
SWITCHES
SCHALTER
INTERRUPTORES

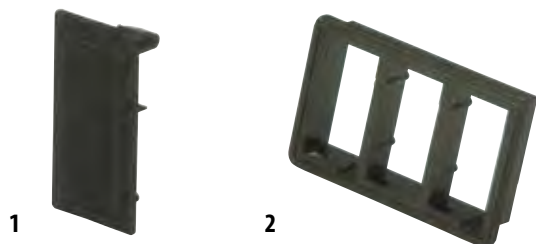

Art./Ref.	Pos.	Note/Note
59053	1	Tappo copri-foro per basculante/ Cover for rocker switch
59056	2	Mostrina a 3 vie/Mostrina a 3 vie/3 Ways frame/Mostrina a 3 vie/Mostrina a 3 vie

INTERRUTTORI BASCULANTI A 12 V

INTERRUPTEURS BASCULANTS 12 V
ROCKER SWITCHES 12 V
TASTENKIPPSCHALTER 12 V
INTERRUPTORES BASCULANTES A 12V



Art./Ref.	Funzione/ Function
59077	Lampeggiante/Beacon
59078	Luci di posizione/Position light
59073	Freno a mano/Parking brake

INTERRUPTORE A TIRETTO CON POMOLO LUMINOSO

INTERRUPTEUR
LUMINOUS PULL-SWITCH
ZIEH-SCHALTER
INTERRUPTOR

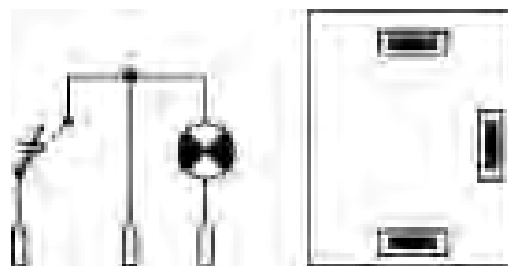

Art./Ref.	Colore/Color	Contatti/Contact
12621	Verde/Green	3 contatti a faston 6,3mm
12622	Rosso/Red	3 contatti a faston 6,3mm

INTERRUPTORE TERGI A LVETTA

INTERRUPTEUR
WIPER SWITCH
SCHALTER
INTERRUPTORES



Art./Ref.	Volt/Volt	Carico max 12Volt/Carico max 12Volt	Note/Note
00766	12V	6A	Levetta piatta in plastica cromata uscite serrafili/ Flat chromium-plated lever terminals screw

COMANDI INDICATORE LIVELLO CARBURANTE

INDICATEURS DE NIVEAU CARBURANT
FUEL LEVEL GAUGES
KRAFTSTOFF MESSERSCHALTUNG NIVEAU
MANDOS INDICADOR NIVEL DEL CARBURANTE

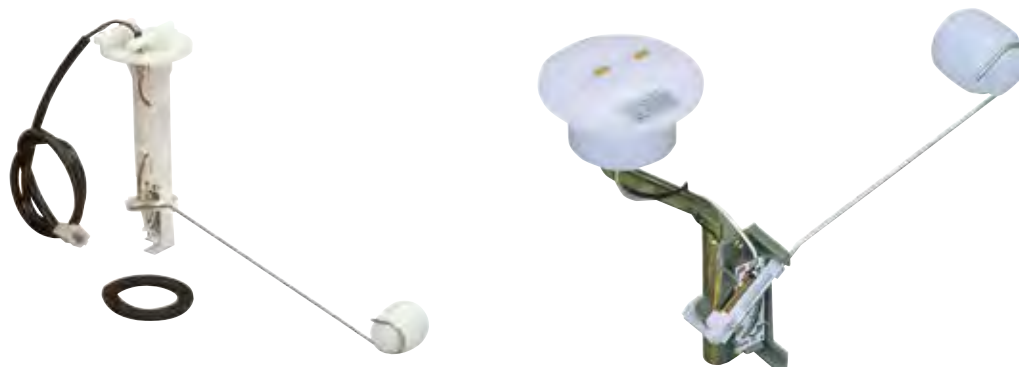

Art./Ref.	Descrizione/Description	Escursione/Range	Taratura/Calibratura	Specifiche/Specifications	Brand	Applicazione/Application	Rif. Orig./Orig. Ref.
26975	Comando indicatore livello carburante con flangia in nylon	275	Livello 0: 300 Livello 1/4: - Livello 1/2: - Livello 3/4: - Livello 4/4: 20	COBO 29.277.000	FIAT	SERIE TN	5170407
01193	Comando indicatore di livello carburante con corpo in acetilica	313	Livello 0: 345-315 Livello 1/4: 228-184 Livello 1/2: 128-108 Livello 3/4: - Livello 4/4: 0-7	COBO 29.089.000	FIAT	55.80, 65,66, 65.80, 70,66, 70.81, 80,46, 80,66, 80,76, 80.81	5136770
01194	Comando indicatore di livello carburante con corpo in acetilica	389	Livello 0: 345-315 Livello 1/4: 228-185 Livello 1/2: 128-108 Livello 3/4: - Livello 4/4: 0-7	COBO 29.088.000	FIAT	100.80, 100.92, 100.95, 110.80, 55.95, 60.95, 65.95, 70.95, 90.80, 90.92, 90.95	5136771

COMANDI INDICATORE LIVELLO CARBURANTE

INDICATEURS DE NIVEAU CARBURANT
 FUEL LEVEL INDICATORS
 KRAFTSTOFF MESSERSCHALTUNG NIVEAU
 MANDOS INDICATOR NIVEL DEL CARBURANTE



Note: Sensore con fissaggio a 6 viti **Notes:** 6 screws fixation sensor

Art./Ref.	Lunghezza mm/Lenght mm	Valore pieno/Full value	Valore vuoto/Empty value	Brand	Rif. Orig./Orig. Ref.
G31137	288	5	330	-	-
58587	374	5	330	SAME	2.7059.890.0
58589	420	5	330	SAME	2.7059.988.0

COMANDI INDICATORI LIVELLO CARBURANTE REGOLABILI CON CORPO IN ACCIAIO

INDICATEURS DE NIVEAU CARBURANT
 FUEL LEVEL GAUGES
 KRAFTSTOFF MESSERSCHALTUNG NIVEAU
 MANDOS INDICADOR NIVEL DEL CARBURANTE

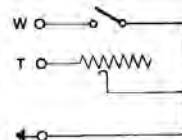
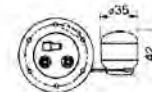
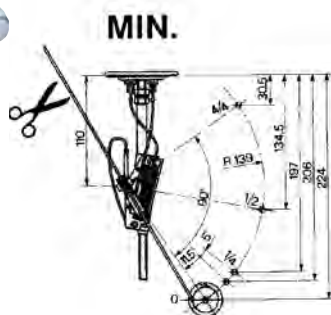

Note: COBO 29.240.000 **Notes:** COBO 29.240.000

Art./Ref.	Taratura/Calibratura
27248	Livello 0: 345-315 Livello 1/4: 228-185 Livello 3/4: - Livello 4/4: 0-7

PULSANTE PER ARRESTO DI EMERGENZA Ø40 MM

INTERRUPTEUR TYPE CHAMPIGNON
 EMERGENCY STOP Ø40 MM
 SICHEREITS-DRUCKKNOPF
 BOTÓN A HONGO TIPO APRETAR - RODAR



Note: Art. 09868: blocco di contatto con base di fissaggio **Notes:** Pn 09868 single contact block with body/fixing collar 1NC screw clamp terminal

Art./Ref.	Dima mm/Dima	Note/Note	Grado di protezione/Protection grade
09867	Ø 22mm per foratura	Ruotare per sbloccare/TURN TO UNLOCK	IP66

ELEMENTO DI CONTATTO CON BASE DI FISSAGGIO CON VITI

ÉLÉMENT DE CONTACT COMPLET DE BASE DE FIXATION AVEC VIS
 SINGLE CONTACT BLOCK WITH BODY/FIXING COLLAR 1NC SCREW CLAMP TERMINAL
 VERBINDUNGSELEMENT FÜR DRUCKKNOPF
 ELEMENTOS DE CONTACTO CON BASE DE FIJACIÓN CON TORNILLOS



Art./Ref.	Specifiche/Specifications
09868	Fissaggio con viti

INTERRUTTORI

COMMUTATEURS
 SWITCHES
 SCHALTER
 INTERRUPTORES

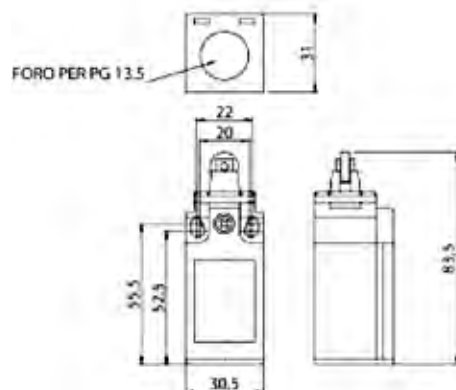
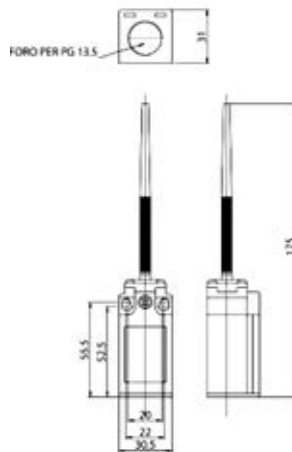

Art./Ref.	Descrizione/Description	Funzione/Funzione	Grado di protezione/Protection grade	Specifiche/Specifications	Servizi/Function
115070	Interruttore di posizione ad asta a molla con puntale	Unità di contatto: 1NO+1NC scatto rapido	IP 67 secondo EN 60529 con pressacavo avente grado di protezione uguale o superiore	Custodia in tecnopolimero, una entrata cavi filettata PG 13,5	-
115121	Interruttore di posizione a pistoncino con rotella	Unità di contatto: 1NO+1NC scatto rapido	IP67 secondo EN 60529 con pressacavo avente grado di protezione uguale o superiore	Custodia in tecnopolimero, una entrata cavi filettata PG 13,5	Apertura positiva: sì

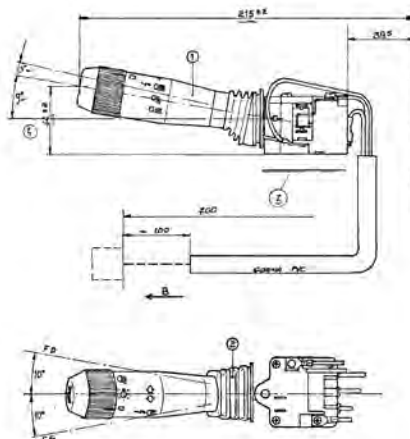
DEVI GUIDA COMANDO LUCI FISSAGGIO A CRUSCOTTO
COMODO DE SIGNALISATION
LIGHT SWITCH LEVER
LICHTLENKSTOCKSCHALTER
DEVI GUIDA COMANDO LUCI FISSAGGIO A CRUSCOTTO

Note: COBO 01.282.000

Notes: COBO 01.282.000

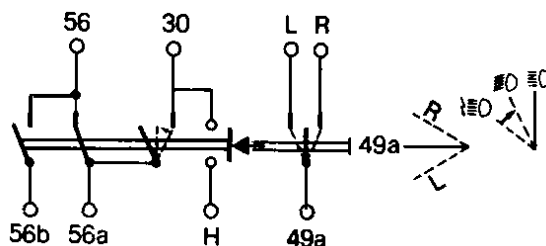
Art./Ref.	Pos.	Ampere/Ampere
18917	6 Posizioni: clacson, frecce, luce anabbagliante, abbagliante, posizione, lampeggio	Posizione clacson: 5A 12V; 3A 24V Luce anabbagliante: 6,5A 12V 4,5A a 24V Luce abbagliante: 7A a 12V 5A a 24V Posizione frecce: 7A a 12V 3A a 24V Luce di posizione: 5A a 12V 3A a 24V Lampeggio: 5a a 12v 3A a 24V

DEVI GUIDA PER FIAT
COMMOTOS POUR FIAT
STEERING COLUMN SWITCHES FOR FIAT
LENKSTOCKSCHALTER FÜR FIAT
SELECTOR PARA MANDO LUCES, BOCINA Y DIRECCIÓN FIAT

Art./Ref.	Descrizione/Description	Funzione/Funzione	Carico max 12Volt/Carico max 12Volt	Carico max 24Volt/24Volt max load	Specifiche/Specifications	Brand	Applicazione/Application	Rif. Orig./Orig. Ref.
00899	Devi guida comando luci con fissaggio a cruscotto	5 funzioni: clacson, luci anabbaglianti, abbaglianti, lampeggio, frecce/5 functions: horn, lights, flash light, turn indicator	Clacson 5A Luci anabbaglianti: 6,5A Luci abbaglianti: 7A Lampeggio: 5A Freccie: 7A	Clacson 3A Luci anabbaglianti: 4,5A Luci abbaglianti: 5A Lampeggio: 3A Freccie: 5A	COBO 01.172.000	FIAT	-	5126127, 5129345, 5143662
26977	Devi guida comando luci	6 Funzioni: Clacson, luci anabbaglianti, abbaglianti, lampeggio, frecce, luce di posizione	Clacson 5A Luci anabbaglianti: 6,5A Luci abbaglianti: 7A Lampeggio: 5A Freccie: 7A Luci di posizione: 5A	Clacson 3A Luci anabbaglianti: 4,5A Luci abbaglianti: 5A Lampeggio: 3A Freccie: 5A Luci di posizione: 3A	-	FIAT	SERIE TN	5174200

DEVIATORI FRECCHE

DEVIATEUR INDICATEUR DE DIRECTION

TRAFFIC INDICATOR SWITCHER

ELEKTRISCHE ZÜNDVORRICHTUNG DES WINKERS

CORRECTOR INDICADOR DE DIRECCIÓN

Art./Ref.	Funzione/ Funzione	Carico max 12Volt/Carico max 12Volt	Carico max 24Volt/24Volt max load	Dima mm/ Dima	Lunghezza Leva/Lun- ghezza Leva	Note/Note	Grado di protezione/Pro- tection grade	Brand	Applicazione/Application	Rif. Orig./ Orig. Ref.
01355	Frecce	Corrente max continua: 8,5A Corren- te di picco 5": 20A	Corrente max continua: 5A Corrente di picco 5": 15A	22,5 mm	31 mm	Senza comando lampeggio/ Without flashing	IP 53	-	-	COBO 15.111.000
10040	Frecce	Corrente max continua: 8,5A Corren- te di picco 5": 20A	Corrente max continua: 5A Corrente di picco 5": 15A	19,9 ÷ 20mm	39 mm	Senza comando lampeggio/ Without flashing	IP 53	-	-	-
26945	Frecce	Corrente max continua: 8,5A Corren- te di picco 5": 20A	Corrente max continua: 5A Corrente di picco 5": 15A	22,5 mm	29 mm	Senza comando lampeggio/ Without flashing	IP 44	FIAT	100.55, 45.66DT, 45.66S, 45.66SDT, 50.66, 50.66DT, 50.66S, 50.66SDT, 55.46DT, 55.56, 55.56DT, 55.66DTLP, 55.66F, 55.66FDT, 55.66LP, 55.66S, 55.66SDT, 55.66V, 55.66VDT, 55.75F, 55.75M, 55.7V, 55.85F, 55.85M, 55.85V, 56.66S, 60.46, 60.46DT, 60.56DT, 60.65M, 60.66F, 60.66FDT, 60.66LP, 60.66LPDT, 60.66S, 60.66SDT, 60.75, 60.75M, 60.75V, 60.85F, 60.85V, 62.85, 62.85M, 65.46DT, 65.56, 65.56DT, 65.66S, 65.66SDT, 70.56, 70.65M, 70.66DT, 70.66F, 70.66FDT, 70.66LP, 70.66LPDT, 70.66SDT, 70.66V, 70.75, 70.75M, 72.85, 72.85M, 80.66F, 80.66SDT, 8075, 82.85MSOM, 85.85MSOM	4998110, 5112714
11256	Frecce, lampeggio, clacson/Fari, frecce, clac- son Lamps, blinking, horns	Corrente max continua: 8,5A Corren- te di picco 5": 20A	Corrente max continua: 5A Corrente di picco 5": 15A	22.5 mm	52 mm	Con comando lampaggio	IP53	-	-	-

TRASMETTITORE A TERMISTORE

THERMISTANCES THERMOM. D'EAU

TEMPERATURE SENDER

WASSERTHERMOMETER IMPULSEGEBER

TRASMISOR TERMÓMETRO AGUA



Art./Ref.	Filettatura/Thread	Chiave/Key	Temperatura/Temperature	Brand	Rif. Orig./Orig. Ref.
03741	M22x1,5	27	0°-150°	FIAT	5108205
03742	M16x1,5	21	0°-150°	VEGLIA-B - FIAT	4171667, 065.9670.990.2
03742C	M16x1,5	21	0°-150°	VEGLIA-B	065.9670.990.2
03743	M14x1,5	21	0°-150°	VEGLIA-B - FIAT	4857250, 065.9672.990.1

INDICATORE TEMPERATURA ACQUA A CAPILLARE

INDICATEUR TEMPERATURE EAU A CAPILLAIRE

CAPILLARY WATER TEMPERATURE METER

WASSERTEMPERATURANZEIGER

INDICADOR TEMPERATURA AGUA DE CAPILAR



Art./Ref.	Lunghezza mm/Lenght mm	Brand	Applicazione/Application	Rif. Orig./Orig. Ref.
01909	800	FIAT	10B, 615, 715, AD9, FL4C	4126690, 4217724
01940	1320	FIAT	615DT, AD10, AD10B, AD4, FL10, FL10B, FL6	4058428, 4058429, 4128723, 4217721, 4241944, 4312905
01941	1670	FIAT	7C, AD/DB7C, AD7, AD8, FL8	4058435, 4217723, 4255318, 43122909, 4312909
01942	2070	FIAT - MASSEY FERGUSON	AD18, FL8C, MF R9500	4058430, 4058431, 4217722, 4241945, 4312906, 77901567, 1822732 M91, 1822732M91, 1822732M93
02000	1780	MASSEY FERGUSON	-	180727M91, 881396M91, 899455M91

1.8.3 Girofari e Piantoni

Revolving warning-lamp & beacon



Ricambi & accessori per macchine agricole

SPARE PARTS & ACCESSORIES FOR AGRICULTURAL MACHINE

Tutti gli articoli della presente sezione, prodotti da AMA SPA e/o da terzi per conto di AMA, sono adattabili ("non originali") alle marche indicate ai sensi di quanto previsto dal REG. CE n. 1400/2002. I diritti sui marchi citati appartengono ai legittimi proprietari ed il loro uso ha l'esclusiva finalità di consentire all'utilizzatore la comparazione dei diversi prodotti. All items of this section, manufactured by AMA SPA and/or any third party on behalf of AMA, are adaptable ("non-original") to the brands listed under the provisions of the REG. CE n. 1400/2002. The rights on the trademarks belong to their respective owners and their usage is only aimed to allow the user to compare different products.

SKYLAR GIROFARI A LED 12-24V

GYROPHARES SKYLAR LED 12-24V
 12-24V LED ROTATING LIGHT SKYLAR
 SKYLAR RUNDUMKENNLEUCHTE LED 12-24V
 SKYLAR LUZ GIRATORIA LED 12-24V



Note: Lampadine incluse

- Omologazione: Reg. 65 ECE-ONU, Reg. 10 ECE-ONU
- Assorbimento di corrente max: 0,7A a 12V, 0,4A a 24V
- IP66 Calotta in policarbonato stabilizzato U.V
- 3 Led

Notes: Bulb included

- Approved: Reg. 65 ECE-ONU, Reg. 10 ECE-ONU
- Current draw: 0,7A to 12V, 0,4A to 24V
- IP66 - Polycarbonate canopy
- 3 Leds

Art./Ref.	Descrizione/Description	Brand	Ricambio/Replacement
71580	Base piana/With flat base	A.M.A.	59099 - Calotta a ricambio skylar / skylar canopy
71581	Base magnetica/Magnetic base and suction cup	A.M.A.	59099 - Calotta a ricambio skylar / skylar canopy
71582	Base imbuto flessibile/Flexible with rod attachment	A.M.A.	59099 - Calotta a ricambio skylar / skylar canopy

HORUS GIROFARI A LED 12-80V

GYROPHARE A LED HORUS 12-80V
 12-80V HORUS LED STROBE LIGHT
 HORUS DREHLEUCHTE LED 12-80V
 FAROS ROTATIVO HORUS 12-80V



Note: 80 quad flash per minuto

- Consumo corrente: 140 mA per 12 V, 45 mA per 80 V
- Temperatura di esercizio: -20°C / +60°C
- Certificazioni: E13

Notes: 80 quad flash per minutes

- Current draw: 140mA to 12 V, 45mA to 80 V
- Operating temperature: -20°C / +60°C
- Approval: E13

Art./Ref.	Descrizione/Description	Brand	Ricambio/Replacement
82802	Base piana /Flat base	A.M.A.	84384 - calotta ambra per 82802-03-04 / amber canopy 82802-03-04, 84385 - calotta BLU per 82802-03-04 / BLUE canopy 82802-03-04
82803	Base magnetica/Magnetic base	A.M.A.	84384 - calotta ambra per 82802-03-04 / amber canopy 82802-03-04, 84385 - calotta BLU per 82802-03-04 / BLUE canopy 82802-03-04
82804	Base ad imbuto flessibile/Flexible rod attachment	A.M.A.	84384 - calotta ambra per 82802-03-04 / amber canopy 82802-03-04, 84385 - calotta BLU per 82802-03-04 / BLUE canopy 82802-03-04

GEA LAMPEGGIANTI A LED 12/24V

GYROPHARE A LED GEA 12-24V
 GEA LED BEACONS 12/24V
 GEA DREHLEUCHTE LED 12-24V
 FAROS ROTATIVO GEA 12-24V



Note: Colore Ambra

- Calotta in PC
- 3Wx 16LED
- IP65
- Omologazioni: CE, EMC, ECE R65

Notes: Amber cover

- PC canopy
- 3Wx16Leds
- IP65
- Approval: CE, EMC, ECE R65

Art./Ref.	Descrizione/Description
62480	Base piana/3-Bolt fixing
62481	Base flessibile con attacco ad asta/Flex din
62482	Base magnetica/Magnetic base

ATENA LAMPEGGIANTI A LED 12-24V

ATENA GYROPHARE A LED 12-24V
 ATENA 12-24V LED BEACONS
 ATENA DREHLEUCHTE LED 12-24W
 FAROS ROTATIVO ATENA 12-24V



Note: 12 Led a 3W

- Colore Ambra
- Lente in PC
- IP65
- Omologazioni: CE, EMC, ECE R65

Notes: 12 leds x 3W

- Amber cover
- PC lens
- IP65
- Approval: CE, EMC, ECE R65

Art./Ref.	Descrizione/Description
60116	Base piana/3-Bolt fixing
60117	Base flessibile con attacco ad asta/Flex din
60118	Base magnetica/Magnetic base

SKYLAR GIROFARI

SKYLAR GYROPHARE
SKYLAR ROTATING LIGHT
SKYLAR RUNDUMKENNLEUCHTE
SKYLAR LUZ GIRATORIA



Note: Omologazione: ECE REG.65 e ECE REG. 10
• Lampadina inclusa
• Assorbimento di corrente max: circa 1,8A a 12Vcc
• IP66
• 20W
• Frequenza di lampeggio: 2,2Hz +/- 3%

Note: Approval: ECE REG.65 e ECE REG. 10
• Bulb included
• Current draw:: circa 1,8A to 12Vcc
• IP66
• 20W
• Flash:: 2,2Hz +/- 3%

Art./Ref.	Descrizione/Description	Volt/Volt	Brand	Ricambio/Replacement
71550	Base piana/Flat base	12V	A.M.A.	58129 - lampadina 12v 20w g4, 59099 - Calotta a ricambio skylar / skylar canopy
71551	Base magnetica/Magnetic base	12V	A.M.A.	02590 - cavo con spinotto / electrical plug and wire, 58129 - lampadina 12v 20w g4, 59099 - Calotta a ricambio skylar / skylar canopy,dis.1909.m -
71552	Base imbuto flessibile/Flexible rod attachment	12V	A.M.A.	58129 - lampadina 12v 20w g4, 59099 - calotta a ricambio skylar / skylar canopy

SERIE ONE GIROFARI BASE PIANA

GYROPHARE ORANGE A BASE PLATE "ONE"
ROTATING LIGHT WITH FLAT BASE "ONE"
ORANGE RUNDUMLEUCHTE MIT GLATTER BASIS "ONE"
LUZ GIRATORIA BASE PLANA



Note: Omologazione R10 -04 13008

Notes: R10 -04 13008 Approval

Art./Ref.	Volt/Volt	Note/Note	Brand	Ricambio/Replacement
34098	12 V	Lampada inclusa/ Bulb included	A.M.A.	08048 - lampada h1 12v 55w (p14,5s) / bulb h1 12v 55w (14,5s), 34107 - calotta arancio serie one / canopy tp 2010668, 75920 - guarniz.x base piana girofaro / guarniz.x base piana girofaro
34099	24 V	Lampada Inclusa/ Bulb included	A.M.A.	08049 - lampada h1 24v 70w (p14,5s) / bulb h1 24v 70w (p14,5s), 34107 - calotta arancio serie one / canopy tp 2010668, 75920 - guarniz.x base piana girofaro / guarniz.x base piana girofaro
34100	12/24V	lampada non inclusa/bulb not included	A.M.A.	02101 - rele" 12v 20/30 amp / relays 12 v,02102 - rele" 24v 10/20 amp / relay 24 v., 08048 - lampada h1 12v 55w (p14,5s) / bulb h1 12v 55w (14,5s), 08049 - lampada h1 24v 70w (p14,5s) / bulb h1 24v 70w (p14,5s), 34107 - calotta arancio serie one / canopy tp 2010668, 75920 - guarniz.x base piana girofaro / guarniz.x base piana girofaro

SERIE ONE GIROFARI A BASE MAGNETICA

GYROPHARE ORANGE A BASE MAGNETIQUE "ONE"

ROTATING LIGHT WITH MAGNETIC BASE "ONE"

ORANGE RUNDUMLEUCHTE MIT MAGNETISCHER "ONE"

LUZ GIRATORIA BASE MAGNETICA "ONE"



Note: Omologazione R10 -04 13008

Notes: R10 -04 13008 approval

Art./Ref.	Volt/Volt	Note/Note	Brand	Ricambio/Replacement
34101	12V	Lampada inclusa/ Bulb included	A.M.A.	02590 - cavo con spinotto / electrical plug and wire, 02591 - spinotto per accendisigari / electrical plug, 03426 - kit magnetico per girofaro / magnetic base for beacon, 08048 - lampada h1 12v 55w (p14,5s) / bulb h1 12v 55w (14,5s), 34107 - calotta arancio serie one / canopy tp 2010668
34102	24V	Lampada inclusa/ Bulb included	A.M.A.	02590 - cavo con spinotto / electrical plug and wire, 02591 - spinotto per accendisigari / electrical plug, 03426 - kit magnetico per girofaro / magnetic base for beacon, 08049 - lampada h1 24v 70w (p14,5s) / bulb h1 24v 70w (p14,5s), 34107 - calotta arancio serie one / canopy tp 2010668
34103	12/24V	Lampada non inclusa/ Bulb not included	A.M.A.	02101 - rele" 12v 20/30 amp / relays 12 v,02102 - rele" 24v 10/20 amp / relay 24 v., 02590 - cavo con spinotto / electrical plug and wire, 02591 - spinotto per accendisigari / electrical plug, 08048 - lampada h1 12v 55w (p14,5s) / bulb h1 12v 55w (14,5s), 08049 - lampada h1 24v 70w (p14,5s) / bulb h1 24v 70w (p14,5s), 34107 - calotta arancio serie one / canopy tp 2010668

SERIE ONE GIROFARI ARANCIO CON ATTACCO AD ASTA

GYROPHARE ORANGE SUR TIGE "ONE"

ROTATING LIGHT WITH ROD ATTACHMENT "ONE"

RUNDUMLEUCHTE MIT BEFESTIGUNG AUF SCHIENE "ONE"

LUZ GIRATORIA CON FIJACION "ONE"



Note: Omologazione R10 -04 13008

Notes: R10 -04 13008 Approval

Art./Ref.	Volt/Volt	Note/Note	Brand	Ricambio/Replacement
34104	12V	Lampada inclusa/ Bulb included	A.M.A.	08048 - lampada h1 12v 55w (p14,5s) / bulb h1 12v 55w (14,5s), 34107 - calotta arancio serie one / canopy tp 2010668
34105	24V	Lampada Inclusa/ Bulb included	A.M.A.	08049 - lampada h1 24v 70w (p14,5s) / bulb h1 24v 70w (p14,5s), 34107 - calotta arancio serie one / canopy tp 2010668
34106	12/24V	Lampada non inclusa/ Bulb not included	A.M.A.	02101 - rele" 12v 20/30 amp / relays 12 v,02102 - rele" 24v 10/20 amp / relay 24 v., 08048 - lampada h1 12v 55w (p14,5s) / bulb h1 12v 55w (14,5s), 08049 - lampada h1 24v 70w (p14,5s) / bulb h1 24v 70w (p14,5s), 34107 - calotta arancio serie one / canopy tp 2010668

SERIE FLEX GIROFARI CON BASE AD ASTA IN GOMMA FLESSIBILE
GYROPHARE FLEXIBLE SUR TIGE "FLEX"
FLEXIBLE ROTATING LIGHT WITH ROD ATTACHMENT "FLEX"
RUNDUMLEUCHTE ORANGE MIT FLEX GUMMIBASIS
LUIZ GIRATORIA FLEXIBLE CON FIJACION "FLEX"

Note: Omologazione R10 -04 13008

Notes: R10 -04 13008 Approval

Art./Ref.	Volt/Volt	Note/Note	Brand	Ricambio/Replacement
34483	12V	Lampada inclusa/Bulb included	A.M.A.	08048 - lampada h1 12v 55w (p14,5s) / bulb h1 12v 55w (14,5s), 35834 - calotta per girofaro serie flex / 34484 beacon lens
35833	24V	Lampada inclusa/Bulb included	A.M.A.	08049 - lampada h1 24v 70w (p14,5s) / bulb h1 24v 70w (p14,5s), 35834 - calotta per girofaro serie flex / 34484 beacon lens
34484	12/24V	Lampada non inclusa/Bulb not included	A.M.A.	08048 - lampada h1 12v 55w (p14,5s) / bulb h1 12v 55w (14,5s), 08049 - lampada h1 24v 70w (p14,5s) / bulb h1 24v 70w (p14,5s), 35834 - calotta per girofaro serie flex / 34484 beacon lens

SERIE "CRIPTO" LAMPADA ROTANTE BASE PIANA
GYROPHARE À BASE PLATE "CRIPTO"
ROTATING LIGHT WITH FLAT BASE "CRIPTO"
ORANGE RUNDUMLEUCHTE MIT GLATTER BASISI "CRIPTO"
LUZ GIRATORIA BASE PIANA

Note: Omologazione R10 -04 13008 valida anche negli stati uniti

Notes: R10 -04 13008 Approval 2008 homologation for USA too

Art./Ref.	Volt/Volt	Note/Note	Brand	Ricambio/Replacement
L03625	12V	Lampadina inclusa / Bulb included	A.M.A.	08048 - lampada h1 12v 55w (p14,5s) / bulb h1 12v 55w (14,5s), 75920 - guarniz.x base piana girofaro / guarniz.x base piana girofaro, I03650 - calotta per girofari serie cripto / rotating light with flat base
L03626	24V	Lampadina inclusa/Bulb included	A.M.A.	08049 - lampada h1 24v 70w (p14,5s) / bulb h1 24v 70w (p14,5s), 75920 - guarniz.x base piana girofaro / guarniz.x base piana girofaro, I03650 - calotta per girofari serie cripto / rotating light with flat base
L03627	12/24V	Lampada non inclusa / Bulb not included	A.M.A.	08048 - lampada h1 12v 55w (p14,5s) / bulb h1 12v 55w (14,5s), 08049 - lampada h1 24v 70w (p14,5s) / bulb h1 24v 70w (p14,5s), I03650 - calotta per girofari serie cripto / rotating light with flat base

SERIE "CRIPTO" LAMPADA ROTANTE CON BASE MAGNETICA

GYROPHARES ORANGE AVEC KIT

REVOLVING WARNING-LAMP WITH MAGNETING KIT, CABLE AND CONNECTION PLUG

ORANGE RUNDUMLEUCHTE MIT STECKER

FAROL VOLVEANTE NARANJADO COMPLETOS CON KIT MAGNETICO CON CABLE Y ARRAGO MONTADO



Note: Omologazione R10 -04 13008 valida anche negli Stati Uniti

Notes: R10 -04 13008 Approval 2008 homologation for USA too supplied with bulb

Art./Ref.	Volt/Volt	Note/Note	Brand	Ricambio/Replacement
L03628	12V	Lampadina Inclusa/Bulb included	A.M.A.	08048 - lampada h1 12v 55w (p14,5s) / bulb h1 12v 55w (14,5s), I03650 - calotta per girofari serie cripto / rotating light with flat base
L03629	24V	Lampadina Inclusa/Bulb included	A.M.A.	08049 - lampada h1 24v 70w (p14,5s) / bulb h1 24v 70w (p14,5s), I03650 - calotta per girofari serie cripto / rotating light with flat base
L03630	12/24V	Lampadina non inclusa/ Bulb not included	A.M.A.	08048 - lampada h1 12v 55w (p14,5s) / bulb h1 12v 55w (14,5s), 08049 - lampada h1 24v 70w (p14,5s) / bulb h1 24v 70w (p14,5s), i18188 - rele 12v 30/40a t/s no+nc / rele 12v 30/40a t/s no+nc,i18189 - , I03650 - calotta per girofari serie cripto / rotating light with flat base

SERIE "CRIPTO" GIROFARO CON ATTACCO AD ASTA

GYROPHARE SUR TIGE "CRIPTO"

ROTATING LIGHT WITH ROD ATTACHMENT "CRIPTO"

ORANGE RUNDUMLEUCHTE MIT BEFESTIGUNG AUF SCHIENE "CRIPTO"

LUZ GIRATORIA CON FIJACION



Note: Omologazione R10 -04 13008 valida anche negli Stati Uniti

Notes: R10 -04 13008 Approval 2008 homologation for USA too

Art./Ref.	Volt/Volt	Note/Note	Brand	Ricambio/Replacement
L03631	12V	Lampadina Inclusa/Bulb included	A.M.A.	08048 - lampada h1 12v 55w (p14,5s) / bulb h1 12v 55w (14,5s), I03650 - calotta per girofari serie cripto / rotating light with flat base
L03632	24V	Lampadina Inclusa/Bulb included	A.M.A.	08049 - lampada h1 24v 70w (p14,5s) / bulb h1 24v 70w (p14,5s), I03650 - calotta per girofari serie cripto / rotating light with flat base
L03633	12/24V	Lampadina non inclusa/ Bulb not included	A.M.A.	08048 - lampada h1 12v 55w (p14,5s) / bulb h1 12v 55w (14,5s), 08049 - lampada h1 24v 70w (p14,5s) / bulb h1 24v 70w (p14,5s), I03650 - calotta per girofari serie cripto / rotating light with flat base

LAMPEGGIANTI FLASH 10-100V

FEU A ECLATS A BASE PLATE "FLASH"
 FLASHING BEACON WITH FLAT BASE "FLASH"
 BLITZLEUCHTE MIT GLATTER BASIS "FLASH"
 LUCE DE DESTELLOS BASE PLANA "FLASH"



Note: Base in polipropilene e calotta in policarbonato. O-Ring di tenuta fra base e calotta. Lampada allo Xenon 1J. Massima corrente assorbita: 68,5 mA a 100 Vdc / 37,6 mA a 24 Vdc / 29,0 mA a 16 Vdc. Frequenza di lampeggio: 1,25 Hz a 100 Vdc / 1,00 Hz a 24 Vdc / 0,60 Hz a 12 Vdc

Notes: PC Lens Xenon bulb 1J Current draw: 68,5mA to 100V, 37,6mA to 24V
 Flash: 1,25Hz to 100V, 1,00Hz to 24V, 0,60Hz to 24V

Art./Ref.	Volt/Volt	Brand	Ricambio/Replacement
37814	10 - 100V	A.M.A.	03426 - kit magnetico per girofaro / magnetic base for beacon

CALOTTA A RICAMBIO SKYLAR

CABOCHON SKYLAR
 SKYLAR CANOPY
 ERSATZGLAS SKYLAR
 TULIPA FARO ROTATIVO SKYLAR



Art./Ref.	Colore/Color
59099	Arancio/Orange

CALOTTA A RICAMBIO HORUS

CABOCHON HORUS
 HORUS CANOPY
 ERSATZGLAS HORUS
 TULIPA FARO ROTATIVO HORUS



Art./Ref.	Colore/Color
84384	Arancio/Orange
84385	Blu/Blue

CALOTTE A RICAMBIO PER GIROFARI

CALOTTE A RECHANGE POUR GIROPHARES
 CANOPY FOR REVOLVING WARNING-LAMP
 KALOTTE FUER RUNDUMLEUCHTE
 CUERPO PARA FARO ROTANTE REPUESTO



Art./Ref.	Colore/Color	Note/Note
34107	Arancio/Orange	serie one
34402	Blu/Blue	serie one
34403	Rosso/Red	serie one
35834	Arancio/Orange	serie flex

CALOTTE A RICAMBIO PER GIROFARI

CALOTTE A RECHANGE POUR GIROPHARES
 CANOPY FOR REVOLVING WARNING-LAMP
 KALOTTE FUER RUNDUMLEUCHTE
 CUERPO PARA FARO ROTANTE REPUESTO



Art./Ref.	Colore/Color	Note/Note
03435	Arancio/Orange	serie pulsar - ajba

CALOTTA PER GIROFARI SERIE CRIPTO

CALOTTE À RECHANGE POUR GYROPHARES
 CANOPY FOR REVOLVING WARNING-LAMP
 ERSATZTEILE KALOTTE FUER RUNDUMLEUCHTE
 CUERPO PARA FARO ROTANTE REPUESTO



Art./Ref.	Colore/Color	Note/Note
L03650	Arancio/Orange	serie cripto

CALOTTA A RICAMBIO ART 37814

CABOCHON POUR 37814
CANOPY FOR 37814
ERSATZGLAS 37814
TULIPA FARO ROTATIVO ART, 37814



Art./Ref.	Colore/Color	Note/Note
DIS.2435	Arancio/Orange	calotta per girofaro flash

BASE MAGNETICA UNIVERSALE PER GIROFARI CON ATTACCO AD ASTA

BASE MAGNÉTIQUE UNIVERSELLE POUR GYROPHARES SUR TIGE
UNIVERSAL MAGNETIC BASE FOR ROTATING BEACONS WITH ROD ATTACHMENT
UNIVERSELLE MAGNETISCHE BASIS FÜR RUNDUMKENNLEUCHTEN MIT AUFSTECKBEFESTIGUNG
BASE MAGNÉTICA UNIVERSAL PARA LUCES GIRATORIAS CON FIJACIÓN ESTANDARD ISO A



Art./Ref.
30967

CAVO PER GIROFARI

CABLE POUR GYROPHARES
CABLE FOR REVOLVING LAMPS
KABEL FÜR RUNDUMLEUCHTE
CABLE PARA FAROL VOLVEANTE



Art./Ref.	Descrizione/Description	Specifiche/Specifications
02590	Cavo spiraleto con spina	Torciglione 2X0,75 cm, Lunghezza 45 cm
02591	Spinotto	2 vie 5A

KIT MAGNETICO

KIT MAGNETIQUE
MAGNETIC KIT
MAGNETISCHER SATZ
KIT MAGNÉTICO



Art./Ref.	Specifiche/Specifications
03426	serie one - cripto - skylar

PARABOLA A RICAMBIO PER GIROFARI

PARABOLE POUR GYROPHARE REFLEKTOR
PARABOLE FOR REVOLVING WARNING-LAMP
PARABEL FÜR RUNDUMLEUCHTE
PARÁBOLA DE REPUESTO PARA FAROL VOLVEANTE



Art./Ref.	Note/Note
34643	per/ for serie one - serie cripto - serie flex

PIANTONI SUPPORTO PER GIROFARO

SUPPORTS POUR GYROPHARE
 BEACON FOR REVOLVING LAMPS
 LAGER FÜR RUNDUMLEUCHTE
 SOPORTE PARA FAROL VOLVEANTE



Note: Bipolari
Notes: Two poles

Art./Ref.	Pos.	Note/Note
03134	4	Piantone da saldare/Adaptor to be welded
03138	1	Piantone da avvitare- fissaggio a vite / Screw-on Beacon holder
03159	2	Piantone con staffa centrale/Adaptor with central bracket
03174	3	Piantone con staffa laterale/Adaptor with side bracket
76499	5	Piantone retraibile/Beacon bracket-retractible
76498	6	Piantone bipolare inclinabile/ Beacon bracket-swivel

TAPPO DI PROTEZIONE PER PIANTONI SUPPORTO GIROFARO

PROTECTION POUR GYROPHARE
 PROTECTION FOR REVOLVING LAMPS
 SCHUTZ FÜR RUNDUMLEUCHTE
 PROTECCIÓN PARA FAROL VOLVEANTE



Art./Ref.

19412

1.8.4 Kit luci rimorchi e trattori

Tractor and trailer light kit



Ricambi & accessori per macchine agricole

SPARE PARTS & ACCESSORIES FOR AGRICULTURAL MACHINE

Tutti gli articoli della presente sezione, prodotti da AMA SPA e/o da terzi per conto di AMA, sono adattabili ("non originali") alle marche indicate ai sensi di quanto previsto dal REG. CE n. 1400/2002. I diritti sui marchi citati appartengono ai legittimi proprietari ed il loro uso ha l'esclusiva finalità di consentire all'utilizzatore la comparazione dei diversi prodotti. All items of this section, manufactured by AMA SPA and/or any third party on behalf of AMA, are adaptable ("non-original") to the brands listed under the provisions of the REG. CE n. 1400/2002. The rights on the trademarks belong to their respective owners and their usage is only aimed to allow the user to compare different products.

KIT LUCI MAGNETICI CON FANALI A LED

KIT ARRIERE MAGNETIQUE LED 7,5X2,5 M
 MAGNETIC LED KIT 7 MT CABLE
 MAGNETISCHE LEUCHTANLAGE LED
 KIT LUCI MAGNETICI CON FANALI A LED



Art./Ref.	Cavo/Cable	Lunghezza mm/Lenght mm	Note/Note	Brand	Ricambio/Replacement
75991	5 poli	7,5 mt + 2,5 mt tra fanali	Confezionamento in valigetta/ Packing case	A.M.A.	02929 - spina 7 poli 12v in plastica / 7 pins clip-plug 12v, 03426 - kit magnetico per girofaro / magnetic base for beacon, 75275 - fanale posteriore quadrato a led 5 funzioni / led rear light

KIT LUCI STANDARD CON FANALI ROTONDI A LED

KIT ARRIERE LED
 LED LIGHT KIT WITH CABLE
 LEUCHTANLAGE LED
 KIT LUCI STANDARD CON FANALI ROTONDI A LED



Art./Ref.	Cavo/Cable	Lunghezza mm/Lenght mm	Brand	Ricambio/Replacement
76418	5 poli	10 m + 4 m tra fanali	A.M.A.	00407 - catarinfrangente bianco ø 60 con vite m5 / white reflector ø 60 with m5 screw, 00426 - catarinfrangente triangolare rosso con viti / red triangular reflector with screws, 02929 - spina 7 poli 12v in plastica / 7 pins clip-plug 12v, 76442 - fanale posteriore led dx ø140mm / rh led rear lamp ø140mm

KIT POSTERIORE MAGNETICO CON CAVO 7,5 M + 2,5 M TRA FANALI

KIT ARRIÈRE AVEC CABLE MAGNETIQUE 7,5MT + 2,5MT ENTRE LES FEUX
 MAGNETIC REAR KIT WITH CABLE 7,5 MT + 2,5MT BETWEEN THE LIGHTS
 RÜCKSEITE SATZ MIT KABEL MAGNETIC 7,5 MT + 2,5MT ZWISCHEN LIGHTS
 KIT TRASERO CON CABLE MAGNETICO 7,5MT + 2,5MT ENTRE LAS LUCES



Art./Ref.	Cavo/Cable	Lunghezza mm/Lenght mm	Note/Note	Brand	Ricambio/Replacement
76448	5 poli	7,5 m + 2,5 m tra fanali	Confezionamento in valigetta/ Packing case	A.M.A.	02929 - spina 7 poli 12v in plastica / 7 pins clip-plug 12v, 03426 - kit magnetico per girofaro / magnetic base for beacon, 10370 - catarinfrangente triangolare rosso con fori / red triangular reflector with holes

KIT LUCI FANALI STANDARD

FEUX KIT
LIGHTS KIT
SATZ
KIT LUCES



Note: Confezionamento in valigetta

Notes: Packing case

Art./Ref.	Cavo/Cable	Lunghezza mm/Lenght mm	Brand	Ricambio/Replacement
76446	5 poli	7,5 mt + 2,5 mt tra fanali	A.M.A.	02929 - spina 7 poli 12v in plastica / 7 pins clip-plug 12v, 76433 - fanale post.dx s/luce targa sm / rh rear lamp, 76434 - fanale post.sx c/luce targa sm / lh rear lamp
76447	5 poli	10 mt + 4 mt tra fanali	A.M.A.	02929 - spina 7 poli 12v in plastica / 7 pins clip-plug 12v, 76433 - fanale post.dx s/luce targa sm / rh rear lamp, 76434 - fanale post.sx c/luce targa sm / lh rear lamp

KIT LUCI MAGNETICI

MAGNETIQUES FEUX KIT
MAGNETIC LIGHTS KIT
SATZ MAGNETISCHE
KIT MAGNETIC



Note: Confezionamento in valigetta

Notes: Packing case

Art./Ref.	Cavo/Cable	Lunghezza mm/Lenght mm	Brand	Ricambio/Replacement
76443	5 poli	7,5mt + 2,5 mt tra fanali	A.M.A.	02929 - spina 7 poli 12v in plastica / 7 pins clip-plug 12v, 03426 - kit magnetico per girofaro / magnetic base for beacon, 76433 - fanale post.dx s/luce targa sm / rh rear lamp, 76434 - fanale post.sx c/luce targa sm / lh rear lamp
76445	5 poli	10 mt + 4 mt tra fanali	-	-

KIT LUCI PER TRATTORI CON CAVO

KIT UNIVERSEL POUR TRACTEURS
 UNIVERSAL KIT LIGHTS FOR TRACTORS
 UNIVERSAL KIT FÜR TRAKTOREN
 KIT UNIVERSAL PARA TRACTORES



Art./Ref.	Lunghezza mm/Lenght mm	Note/Note	Brand	Ricambio/Replacement
02910	cavo 4m	Cablaggio con accessori premontati/ Pre-assembled wiring accessories.	A.M.A.	00464 - fanale direzione- posizione dx e sx 114x76mm / front lamp 114x76mm, 00707 - intermittenza 12 v 46/180 w / flasher unit 12v 21/99w 3 pin, 02428 - staffa a "I" universale / universal support "I", 02429 - interruttore stop (2910) / stop switch standard, 02817 - fanale posteriore alogeno dx 162x70mm / rh halogen rear lamp 162x70mm 02818 - fanale posteriore alogeno sx 162x70mm / lh halogen rear lamp 162x70mm 02853 - spia verde frecce / green warning light, 02930 - presa 7 poli 12v in plastica / 7 pin plastic socket 12v,i15204 -

KIT LUCI RIMORCHIO CON STAFFE RIBALTABILI 7,5 MT.+ 2,2 MT. TRA I FANALI

KIT LUMIÈRE DUMP TRAILER DE SUPPORTS
 FOLDIN TRAILER LIGHT KIT WITH BRACKETS
 KIPPANHANGER LIGHT MIT HALTERN
 TRAILER DE DESCARGA DE LUZ KIT DE SOPORTES



Art./Ref.	Cavo/Cable	Lunghezza mm/Lenght mm	Note/Note	Brand	Ricambio/Replacement
00429	5 poli	7,5 mt + 2,2 mt tra i fanali	Cablaggio con accessori premontati Pre- assembled wiring accessories	A.M.A.	00407 - catarinfrangente bianco ø 60 con vite m5 / white reflector ø 60 with m5 screw, 00426 - catarinfrangente triangolare rosso con viti / red triangular reflector with screws, 02816 - portatarga (429-1615) / holder-number-plate, 02929 - spina 7 poli 12v in plastica / 7 pins clip-plug 12v, 56016 - fanale alogeno posteriore dx 100x105mm / rh halogen rear lamp 100x105mm, 56017 - fanale alogeno posteriore sx 100x105mm / lh halogen rear lamp 100x105mm,s09002 - ,s09003 -

KIT LUCI PER RIMORCHI 7 M.+ 2,2M TRA I FANALI

FEUX KIT POUR REMORQUES
 KIT LIGHTS FOR TRAILERS
 KIT LIGHTS FÜR ANHÄNGER
 LUCES DE KIT PARA REMOLQUES



Art./Ref.	Cavo/Cable	Lunghezza mm/Lenght mm	Note/Note	Brand	Ricambio/Replacement
02874	5 poli	7 m + 2,2 m tra fanali	Cablaggio con accessori premontati /Pre-assembled wiring accessories	A.M.A.	00407 - catarinfrangente bianco ø 60 con vite m5 / white reflector ø 60 with m5 screw, 00426 - catarinfrangente triangolare rosso con viti / red triangular reflector with screws, 02817 - fanale posteriore alogeno dx 162x70mm / rh halogen rear lamp 162x70mm , 02818 - fanale posteriore alogeno sx 162x70mm / lh halogen rear lamp 162x70mm , 02929 - spina 7 poli 12v in plastica / 7 pins clip-plug 12v

BARRA A LED PORTAFANALI ESTENSIBILE PER RIMORCHI

RAMPE D'ECLAIRAGE COMPLETE POUR REMORQUES - LONGUEUR REGLABLE
 COMPLETE LIGHTING SET FOR TRAILERS - ADJUSTABLE LENGHT
 ANHÄBGERLEUCHTANLAGE - ZUSAMMENSCHIEBBAR - FESTE STANGE
 BARRA PORTAFAROLAS POSTERIORES PARA REMOLQUE LARGUEZA REGULABLE



Art./Ref.	Tipo/Type	Lunghezza mm/Lenght mm	Cavo/Cable	Note/Note	Brand	Ricambio/Replacement
85459	Regolabile/Extendable	1400 ÷ 2100 mm	7,5 m	Omologazione: E4 E11/E4 E11 Approval	A.M.A.	02929 - spina 7 poli 12v in plastica / 7 pins clip-plug 12v, 10370 - catarinfrangente triangolare rosso con fori / red triangular reflector with holes, 75275 - fanale posteriore quadrato a led 5 funzioni / led rear light

BARRA PORTAFANALI POSTERIORE PER RIMORCHI - LUNGHEZZA REGOLABILE

RAMPE D'ECLAIRAGE COMPLETE POUR REMORQUES - LONGUEUR REGLABLE -
 COMPLETE LIGHTING SET FOR TRAILERS - ADJUSTABLE LENGHT
 ANHÄBGERLEUCHTANLAGE - ZUSAMMENSCHIEBBAR - FESTE STANGE
 BARRA PORTAFAROLAS POSTERIORES PARA REMOLQUE LARGUEZA REGULABLE



Art./Ref.	Tipo/Type	Lunghezza mm/Lenght mm	Cavo/Cable
02931	Regolabile Adjustable	1260 ÷ 2060 mm	5 poli, 7,5 mm

BARRE REGOLABILI PER IMPIANTO LUCI CON CAVO A 5 POLI
RAMPE D'ECLAIRAGE COMPLETE POUR REMORQUES
COMPLETE LIGHTING SET FOR TRAILERS
ANHÄNGERLEUCHTANLAGE
BARRA PORTAFAROLE POSTERIORES PARA REMOLQUES

Art./Ref.	Tipo/Type	Lunghezza mm/Lenght mm	Cavo/Cable	Note/Note	Ricambio/Replacement	Kit/null
76444	Regolabile/ Extendable	1400 ÷ 2100 mm	5 poli, 7,5 m	Omologazio- ne E11/E11 Approval	02929 - spina 7 poli 12v in plastica / 7 pins clip-plug 12v, 10370 - catarinfrangente triangolare rosso con fori / red triangular reflector with holes, 76433 - fanale post.dx s/luce targa sm / rh rear lamp, 76434 - fanale post.sx c/luce targa sm / lh rear lamp	DIS.2410

PARAURTI PVC LED 1,37M CAV12 M
RAMPE ECLAIRAGE LED PVC 1,37M
LED LIGHT PVC BOARD 1,37M 12M CABLE
ANHAENGERLEUCHTANLAGE LED 1,37
BARRA LED 1,37 M 7 PIN 10 M

Art./Ref.	Lunghezza mm/Lenght mm	Cavo/Cable	Brand	Ricambio/Replacement
75999	1370 mm	5 poli, 12 m	A.M.A.	10370 - catarinfrangente triangolare rosso con fori / red triangular reflector with holes, 75275 - fanale posteriore quadrato a led 5 funzioni / led rear light

BARRE PORTAFANALI POSTERIORI PER RIMORCHI
RAMPE D'ECLAIRAGE COMPLETE POUR REMORQUES - LONGUEUR REGLABLE - FIXE
COMPLETE LIGHTING SET FOR TRAILERS - ADJUSTABLE LENGHT - FIX LENGTH
ANHÄNGERLEUCHTANLAGE - ZUSAMMENSCHIEBBAR - FESTE STANGE
BARRA PORTAFAROLE POSTERIORES PARA REMOLQUE LARGUEZA REGULABLE - FIJA

Art./Ref.	Tipo/Type	Lunghezza mm/Lenght mm	Cavo/Cable	Ricambio/Replacement
04859	Regolabile/ Adjustable	1180 ÷ 1720 mm	5 poli, 7 m	02929 - spina 7 poli 12v in plastica / 7 pins clip-plug 12v, 10370 - catarinfrangente triangolare rosso con fori / red triangular reflector with holes, 56016 - fanale alogeno posteriore dx 100x105mm / rh halogen rear lamp 100x105mm, 56017 - fanale alogeno posteriore sx 100x105mm / lh halogen rear lamp 100x105mm, dis.2159 - portatarga x barra posteriore

PARAURTI POSTERIORI IN ALLUMINIO CON FANALI PER RIMORCHI AGRICOLI
PARECOCH COMPLET POUE REMORQUES
BUMPER FOR TRAILERS
STOSSSTANGE MIT ANGEBAUTEN LEUCHTEN
PARACHOQUE POSTERIOR CON FAROLES PARA REMOLQUES AGRICULOS

Art./Ref.	Lunghezza mm/Lenght mm	Cavo/Cable	Brand	Ricambio/Replacement
75996	1750 mm	5 poli, 7,5 m	A.M.A.	02929 - spina 7 poli 12v in plastica / 7 pins clip-plug 12v,76477 - set 2 fanali posteriori alogeni dx e sx 237x137mm / set 2 halogen rear lamp rh e lh 237x137mm
75997	1950 mm	5 poli, 7,5m	A.M.A.	02929 - spina 7 poli 12v in plastica / 7 pins clip-plug 12v,76477 - set 2 fanali posteriori alogeni dx e sx 237x137mm / set 2 halogen rear lamp rh e lh 237x137mm

BARRA POSTERIORE PVC
PVC BUMPER FOR TRAILERS
PARECOCH PVC COMPLET POUE REMORQUES
PVC STOSSSTANGE MIT ANGEBAUTEN LEUCHTEN
PARACHOQUE POSTERIOR PVC CON FAROLES PARA REMOLQUES AGRICULOS

Art./Ref.	Tipo/Type	Lunghezza mm/Lenght mm	Cavo/Cable	Brand	Ricambio/Replacement
85614	PVC	1,37m	12m	A.M.A.	10370 - catarinfrangente triangolare rosso con fori / red triangular reflector with holes, 76433 - fanale post.dx s/luce targa sm / rh rear lamp, 76434 - fanale post.sx c/luce targa sm / lh rear lamp, 76449 - rodov per 76433 - 76434 / lens for 76433 - 76434
85615	PVC	1,68m	12m	A.M.A.	10370 - catarinfrangente triangolare rosso con fori / red triangular reflector with holes, 76433 - fanale post.dx s/luce targa sm / rh rear lamp, 76434 - fanale post.sx c/luce targa sm / lh rear lamp, 76449 - rodov per 76433 - 76434 / lens for 76433 - 76434

KIT PORTATARGA COMPLETO DI FANALI CON PARAURTO IN PLASTICA
KIT PORTE-PLAQUE D'IMMATRICULATION COMPLETE DE FEUX, AMPOULES, FICHE 7 POLE ET CABLE
NUMBER PLATE HOLDER KIT COMPLETE WITH TRAILER LIGHTS, BULBS, 7 POLE PLASTIC PLUG AND CABLE
NUMMERNESCHILDTRÄGER-BAUSATZ, BESTEHEND AUS LEUCHTEN GLÜHLAMPEN, 7 POLIGER STECKER, KABEL
KIT PORTACHATA COMPLETO CON FAROLES, LAMPARILLAS, ENCHUFE HEMBRA 7 POLOS Y CABLE

Art./Ref.	Tipo/Type	Cavo/Cable	Lunghezza mm/Lenght mm	Brand	Ricambio/Replacement
04857	PVC	5 poli, 4,5 m	750 mm	A.M.A.	02929 - spina 7 poli 12v in plastica / 7 pins clip-plug 12v, 56016 - fanale alogeno posteriore dx 100x105mm / rh halogen rear lamp 100x105mm, 56017 - fanale alogeno posteriore sx 100x105mm / lh halogen rear lamp 100x105mm

BARRA PER SEGNALETICA POSTERIORE IN PLASTICA

RAMPE DE SIGNALISATION COMPLETE DE FEUX, AMPOULES, CATADIOPTRES, FICHE 7 POLE ET CABLE
 TRAILER BOARD COMPLETE WITH LIGHTS, BULBS, REFLECTORS, 7 POLE PLASTIC PLUG AND CABLE
 ANHÄNGER-BELEUCHTUNGSATZ, BESTEHEND AUS LEUCHTEN GLÜHLAMPEN, 7 POLIGER STECKER, KABEL
 BARRA PARA SEÑALIZACIÓN POSTERIOR COMPLETA CON FAROLES, LAMPARILLAS, CATAFAROS, ENCHUFE Y CABLE



Art./Ref.	Tipo/Type	Cavo/Cable	Lunghezza mm/Lenght mm	Brand	Ricambio/Replacement
04863	PVC	5 poli, 4,5 m	1050 mm	A.M.A.	02929 - spina 7 poli 12v in plastica / 7 pins clip-plug 12v, 10370 - catarinfrangente triangolare rosso con fori / red triangular reflector with holes, 56016 - fanale alogeno posteriore dx 100x105mm / rh halogen rear lamp 100x105mm, 56017 - fanale alogeno posteriore sx 100x105mm / lh halogen rear lamp 100x105mm

STAFFA UNIVERSALE PER FANALI ANTERIORI E POSTERIORI

SUPPORT UNIVERSAL POUR FEUX AVANT ET ARRIERE
 REAR AND FRONT LAMP SUPPORT
 UNIVERSALGELENK FÜR VORDERE UND HINTERE LEUCHTE
 SOPORTE UNIVERSAL PARA FAROLES ANTERIORES Y POSTERIORES



Art./Ref.
02428

PORTATARGA ZINCATO

SUPPORT - PLAQUE ZINGUE'
 GALVANIZED NUMBER PLATE SUPPORT
 VERZINKTER TAFELTRÄGER
 PORTACHAPA CINCADO

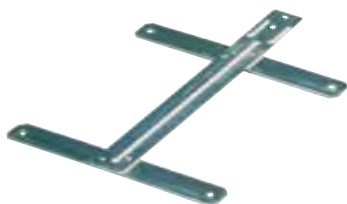

Art./Ref.
02816

PORTATARGA

TITULAIRE
 LICENSE PLATE
 HALTER
 TITULAR



Art./Ref.	Tipo/Type	Lunghezza mm/Lenght mm
DIS.2410	Alluminio/Aluminum	250x165 mm

PORTATARGA

TITULAIRE
 LICENSE PLATE
 HOLDER
 TITULAR



Art./Ref.	Tipo/Type	Lunghezza mm/Lenght mm
DIS.2159	lamiera pre-zincata /pre-galvanized sheet	160x163 mm

1.8.5 Pannelli e Catadiottri

Panels & Reflectors



Ricambi & accessori per macchine agricole

SPARE PARTS & ACCESSORIES FOR AGRICULTURAL MACHINE

Tutti gli articoli della presente sezione, prodotti da AMA SPA e/o da terzi per conto di AMA, sono adattabili ("non originali") alle marche indicate ai sensi di quanto previsto dal REG. CE n. 1400/2002. I diritti sui marchi citati appartengono ai legittimi proprietari ed il loro uso ha l'esclusiva finalità di consentire all'utilizzatore la comparazione dei diversi prodotti. All items of this section, manufactured by AMA SPA and/or any third party on behalf of AMA, are adaptable ("non-original") to the brands listed under the provisions of the REG. CE n. 1400/2002. The rights on the trademarks belong to their respective owners and their usage is only aimed to allow the user to compare different products.

CATARINFRANGENTI CON FORO, CON VITE, ADESIVI
CATADIOPTRE AVEC TROU, AVEC VIS ET ADHESIF
REFLECTORS WITH HOLE, WITH SCREW, AND ADHESIVE
RUCKSTRAHLER MIT LOCK, MIT SCHRAUBE UND SELBSTKLEBENDER
CATADIOPTRICO CON AGUJERO, CON TOMILLO Y ADHESIVO

Art./Ref.	Diametro mm/Diameter mm	Colore/Color	Fissaggio/Fissaggio
00407	60	Bianco/White	Prigioniero M5/M5 screw e nut
00408	60	Rosso/Red	Prigioniero M5/M5 screw e nut
01367	60	Arancio/Orange	Prigioniero M5/M5 screw e nut
00476	80	Bianco/White	Prigioniero M5/M5 screw e nut
00410	80	Rosso/Red	Prigioniero M5/M5 screw e nut
00477	80	Arancio/Orange	Prigioniero M5/M5 screw e nut
01649	60	Bianco/White	Adesivo/Self-adhesive
01651	60	Rosso/Red	Adesivo/Self-adhesive
01650	60	Arancio/Orange	Adesivo/Self-adhesive
10371	60	Bianco/White	Con foro/With hole
10373	60	Rosso/Red	Con foro/With hole
10372	60	Arancio/Orange	Con foro/With hole

CATARINFRANGENTI RETTANGOLARI ADESIVI E CON FORI
CATADIOPTRES RECTANGULAIRES ADHESIF ET AVEC TROUS
REFLECTOR WITH HOLES AND ADHESIVE
RUCKSTRAHLER MIT LOCKER UND SELBSTKLEBENDER
CATADIOPTRICOS ADHESIVO Y CON AGUJEROS

Art./Ref.	Colore/Color	Misure/Sizes	Fissaggio/Fissaggio
03917	Bianco/White	57x39	Adesivo/Self-adhesive
03919	Rosso/Red	57x39	Adesivo/Self-adhesive
03918	Arancio/Orange	57x39	Adesivo/Self-adhesive
03920	Bianco/White	105x48	Adesivo/Self-adhesive
03922	Rosso/Red	105x48	Adesivo/Self-adhesive
03921	Arancio/Orange	105x48	Adesivo/Self-adhesive
19735	Rosso/Red	105x48	Fori ø 4, Interasse 90 mm / ø4 holes, distance 90 mm
19736	Arancio/Orange	105x48	Fori ø 4 Interasse 90mm / ø4 holes, distance 90mm

CATARINFRANGENTI TRIANGOLARI
CATADIOPTRE TRIANGULAIRE
TRIANGULAR REFLECTORS
RUCKSTRAHLER DREIECKIG
CATADIOPTRICO TRIANGULAR

Art./Ref.	Fissaggio/Fissaggio	Blister/Packaging
00426	Prigioniero M6/M6 screw e nut/Prigioniero M6/Prigioniero M6	-
10370	Con fori/With holes	-
10370C	Con fori/With holes	Blister da 2pz

CATARINFRANGENTE RETTANGOLARE 98X62MM

CATADIOPTRE RECTANGULAIRE 98X62MM
 REFLECTOR RECTANGULAR 98X62MM
 RUCKSTRAHLER 98X62MM
 CATADIOPTRICO RECTANGULARES 98X62MM



Art./Ref.	Colore/Color	Misure/Sizes	Fissaggio/Fissaggio	Lunghezza mm/Lenght mm
06113	Rosso/Red	98x62 mm	con 2 prigionieri M6 /with 2 stud bolt	45 mm interasse
69302	Arancio/Orange	98x62 mm	con 2 prigionieri M6 /with 2 stud bolt	45 mm interasse

PANNELLI SEGNALEZIONE CARICHI SPORGENTI

PANNEAUX HORS-GABARIT HOMOLOGUÉS ITALIENS
 REAR REFLECTING PANEL FOR PROTRUDING LOADS ITALY
 ITALIENISCHE BAUARTGEPRÜFTE ÜBERBREITENTAFELN
 PANEL REFLECTANTE CE

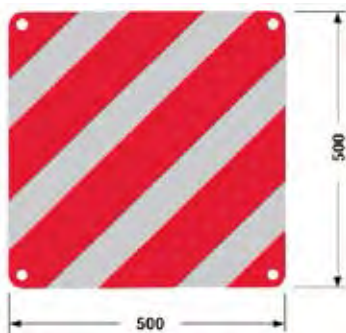

Note: Omologato CE

Notes: CE approved

Art./Ref.	Materiale/Material	Fissaggio/Fissaggio
04034	Alluminio/Aluminium	Con angoli arrotondati e con 4 fori rivettati/Panel with 4 riveted holes and rounded corners

KIT 2 PANNELLI RIMORCHIO PORTATA ?3500 KG ECE ONU 70

JEU DE 2 PANNEAUX REMORQUE PTAC ?3500KG ECE 70
 KIT 2 TRAILER PANELS ? 3500 KG ECE ONU 70
 SATZ 2 ANHÄNGER-TAFELN GESAMTLAST? 3500KG UN ECE R 70
 KIT 2 PANELES DE REMOLQUE CAPACIDAD ? 3500 KG ECE ONU 70



Note: Conforme regolamento Ece Onu 70 per circolazione in tutta Europa

Notes: In conformity with the regulation ECE 70

Art./Ref.	Materiale/Material	Misure/Sizes
04029	Alluminio/Aluminium	565X196 mm

KIT 2 PANNELLI PER SEGNALAZIONE ATTREZZATURE AGRICOLE

JEU DE 2 PANNEAUX RÉTRO RÉFLÉCHISSANTS ET FLUORESCENTS SELON ARRÊTÉ NO. 391 DU 19 JUIN 1992

KIT 2 REAR AGRICULTURAL PANELS

SATZ 2 REFLEKTIERENDE UND FLUOREZIERENDE TAFELN NACH MINISTERIALDEKRET NR. 391 VOM 19 JUNI 1992

2 PANELES PARA MAQUINARIA AGRICULOS



Note: D.M. n° 931 del 19 giugno 1992

Notes: D.M. n° 931 del 19 giugno 1992

Art./Ref.	Materiale/Material	Misure/Sizes
04031	Alluminio/Aluminium	564x282x2 mm

PANNELLO PER SEGNALAZIONE DELLE ATTREZZATURE AGRICOLE

PANNEAU RÉTRO RÉFLÉCHISSANT ET FLUORESCENT SELON ARRÊTÉ NO. 391 DU 19 JUIN 1992

PANEL INDICATING AGRICULTURAL EQUIPMENT

REFLEKTIERENDE UND FLUOREZIERENDE TAFEL NACH MINISTERIALDEKRET NR. 391 VOM 19 JUNI 1992

PANEL PARA MAQUINARIA AGRICULOS



Note: D.M. n° 931 del 19 giugno 1992

Notes: D.M. n° 931 del 19 giugno 1992

Art./Ref.	Materiale/Material	Misure/Sizes
04030	Alluminio/Aluminium	423x423x2 mm

KIT 2 PANNELLI POSTERIORI RETRORIFLETTENTI E FLUORESCENTI PER AUTOCARRI CONFORMI AL REGOLAMENTO ECE ONU 70

JEU DE 2 PANNEAUX CAMION PTAC ?3500KG ECE 70

REAR-REFLECTING PANELS FOR TRUCK TRACTORS

SATZ 2 LKW-TAFELN GESAMTLAST ?3500KG UN ECE R 70

PAR DE CUADRO RETROREFLEJANTE PARA MOTRICES



Art./Ref.	Materiale/Material
04024	Alluminio/Aluminium

KIT 2 PANNELLI POSTERIORI RETRORIFLETTENTI E FLUORESCENTI PER AUTOCARRI CONFORMI AL REGOLAMENTO ECE ONU 70 01

JEU DE 2 PANNEAUX CAMION PTAC ?3500KG ECE 70 01

KIT 2 TRUCK PANELS ? 3500 KG ECE 70 01

SATZ 2 LKW-TAFELN GESAMTLAST ?3500KG UN ECE R 70 01

KIT 2 PANELES DE CAMIONES DE CAPACIDAD ? 3500 KG ECE ONU 70 01



Art./Ref.	Materiale/Material
59791	Alluminio/Aluminium

PANNELLO AGRICOLO DIN 11030

PANNEAU RETRO RÉFLÉCHISSANT POUR LA SIGNALISATION DES CHARGES SAILLANTS

REAR REFLECTING CARGOS SIGNAL PANEL

RÜCKSTRAHLENDE WARNTAFELN FÜR DIE MARKIERUNG ÜBERSTEHENDER

PANEL RETROREFLEJANTE PARA SEÑALAR GARGAS SALIENTES



Art./Ref.	Misure/Sizes	Materiale/Material
12441	423x423 mm	zincato /zinc plated

TRIANGOLO ALLUMINIO ECE 69.01 PER VEICOLI AGRICOLI LENTI

TRIANGLE ALUMINIUM ECE 69.01 POUR VEHICULES AGRICOLES A PROGRESSION LENTE

WARNING TRIANGLE ECE 69.01 FOR SLOW MOVING VEHICLES

DREIECK ALUMINIUM ECE 69.01 FÜR LANGSAM FAHRENDE LANDWIRTSCHAFTSMASCHINEN

TRIÁNGULO DE ALUMINIO ECE 69.01 PARA VEHÍCULOS AGRÍCOLAS

**Note:** Richiesto in Italia, Germania, Olanda, Danimarca, Finlandia, Estonia, Svezia

Art./Ref.	Misure/Sizes	Colore/Color
12439	365 x 365x1,5 mm	Rosso/Red

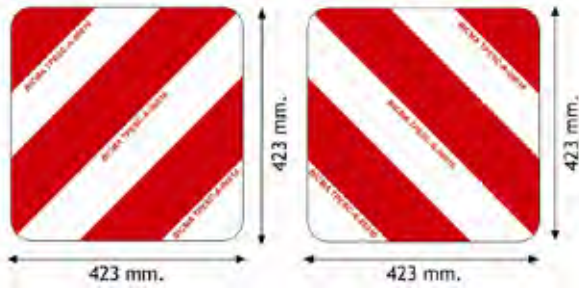
KIT 2 PANNELLI PER CONVOGLI AGRICOLI FRANCESI
JEU DE 2 PANNEAUX CARRÉS
KIT OF 2 SQUARE PANELS FOR FRENCH AGRICULTURAL VEHICLES
SATZ 2 QUADRATISCHE TAFELN
KIT 2 PANELES PARA MAQUINARIA AGRICOLA FRANCES

Note: Pellicola rinfrangente rossa e bianca in classe 1, omologata TPESC

Notes: Reflecting red and white film class 1, TPESC approval

Art./Ref.	Misure/Sizes	Materiale/Material
85499	423x423x1	Alluminio/Aluminium

PANNELLO "CONVOI AGRICOLE"
PANNEAU "CONVOI AGRICOLE"
"CONVOI AGRICOLE" PANEL
WARNTAFEL "CONVOI AGRICOLE"
PANEL "CONVOI AGRICOLE"

Note: Pellicola rinfrangente classe 2

Notes: Reflecting film class 2

Art./Ref.	Misure/Sizes	Materiale/Material
57819	1200X400X1 mm	Alluminio/Aluminium

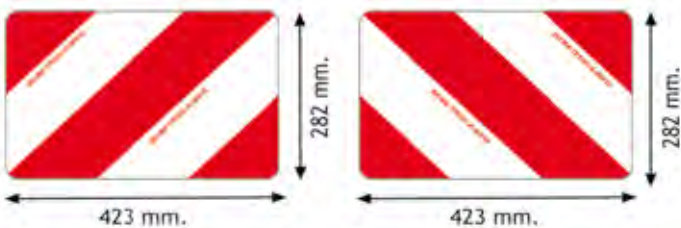
KIT 2 PANNELLI PER CONVOGLI AGRICOLI FRANCESI
KIT 2 PANNEAUX POUR CONVOI AGRICOLE FRANCAIS
KIT OF 2 PANELS FOR FRENCH AGRICULTURAL VEHICLES
WARNEFOLIE SELBSTKLEBEND FRENCH TPESC
KIT 2 PANELES PARA MAQUINARIA AGRICOLA FRANCES

Note: Pellicola rinfrangente rossa e bianca in classe 1, omologata TPESC

Notes: Reflecting red and white film class 1, TPESC approval

Art./Ref.	Misure/Sizes	Materiale/Material
57818	423x282x1 mm	Alluminio/Aluminium

PANNELLI DI SEGNALAZIONE DELLE ATTREZZATURE AGRICOLE PER GERMANIA

PLAQUES DES ÉQUIPEMENTS POUR EQUIPMENT AGRICOLE POUR ALLEMAGNE

PANELS INDICATING AGRICULTURAL EQUIPMENT FOR GERMANY

WARNFOLIE SELBSTKLEBEND DIN 11030

PANELS DE INFORME DEL EQUIPO DE AGRICULTURA

**Note:** DIN 11030

Art./Ref.	Fissaggio/Fissaggio	Misure/Sizes	Materiale/Material
57821	Dx/Rh	423x423x0,8mm	zincato /zinc plated
57822	Sx/Lh	423X423X0,8 mm	zincato /zinc plated

NASTRO RETRORIFLETTENTE OMOLOGATO PER SEGNALAZIONE SAGOME VEICOLI

BANDE RETRO REFLECHISS

REFLECTING TAPE

BAND REUKSTRAHLEND

CINTA RETROREFLECTORA

**Note:** Decreto ECE ONU 104**Notes:** ECE ONU 104

Art./Ref.	Colore/Color	Misure/Sizes
57857	Giallo/Yellow	Larghezza: 50 mm; Lunghezza: 50 m
57858	Bianco/White	Larghezza: 50 mm; Lunghezza: 50 m
57859	Rosso/Red	Larghezza: 50 mm; Lunghezza: 50 m

SEGNALI DI VELOCITA' OMOLOGATI PER ITALIA

DISQUE ADHESIF DE LIMITATION DE VITESSE POUR ITALIE

SELF-ADHESIVE SPEED LIMIT DISCS FOR ITALY

SELBSTKLEBEFOLIE RUND FÜR ITALIEN

ETIQUETAS LIMITE DE VELOCIDAD PARA ITALIA

**Note:** Segnalazione secondo D.L. n° 285 del 30/04/1992, DPR n° 495 del 16/12/199

Art./Ref.	Numero/Numero	Fissaggio/Fissaggio	Diametro mm/Diameter mm
04033	40 Km/h	Adesivo/Self-adhesive	200 mm
04023	40 Km/h	Alluminio/Aluminium	200 mm
59108	70 Km/h	Adesivo/Self-adhesive	200 mm
59109	80 Km/h	Adesivo/Self-adhesive	200 mm

SEGNALI DI VELOCITA' ADESIVI PER GERMANIA

DISQUE ADHESIF DE LIMITATION DE VITESSE POUR ALLEMAGNE
 SELF-ADHESIVE SPEED LIMIT DISCS FOR GERMAN
 SELBSTKLEBEFOLIE RUND FÜR DEUTSCHLAND
 ETIQUETAS LIMITE DE VELOCIDAD PARA ALEMANIA

Note: Adesivi, Tipo tedesco, Materiale PVC, ø 200 mm

Notes: Self-adhesive, PVC material, ø 200 mm

Art./Ref.	Numero/Numero
59101	16 Km/h
59102	20 Km/h
59103	25 Km/h
59104	40 Km/h
59105	50 Km/h
59106	60 Km/h
59107	80 Km/h



Tipo tedesco / German type

SEGNALI DI VELOCITA' ADESIVI PER FRANCIA

DISQUE ADHESIF DE LIMITATION DE VITESSE POUR FRANCE
 SELF-ADHESIVE SPEED LIMIT DISCS FOR FRENCH
 SELBSTKLEBEFOLIE RUND FÜR FRANKREICH
 ETIQUETAS LIMITE DE VELOCIDAD PARA FRANCIA

Note: Adesivi, Tipo francese, Materiale PVC, ø 200 mm

Notes: Self-adhesive, French type, PVC material, ø 200 mm

Art./Ref.	Numero/Numero
59191	60 Km/h
59192	70 Km/h
59193	80 Km/h
59194	90 Km/h



Tipo francese / French type

SEGNALI DI VELOCITA' ADESIVI PER BELGIO

DISQUE ADHESIF DE LIMITATION DE VITESSE POUR BELGIQUE
 SELF-ADHESIVE SPEED LIMIT DISCS FOR BELGIUM
 SELBSTKLEBEFOLIE RUND FÜR BELGIEN
 ETIQUETAS LIMITE DE VELOCIDAD PARA BELGICA

Note: Adesivi, Tipo tedesco, Materiale cl.1, ø 210 mm

Notes: Self-adhesive, Belgium type, Material CL.1, ø 210 mm

Art./Ref.	Numero/Numero
59121	40 Km/h
59122	60 Km/h
59123	70 Km/h



Tipo belga / Belgium type

TARGA RIPETITRICE BIFACCIALE BIANCA/GIALLA PER RIMORCHI AGRICOLI

PLAQUE D'IMMATRICULATION RÉPÉTITIVE DOUBLE FACE (BLANCHE/JAUNE) POUR REMORQUES AGRICOLES
 DOUBLE-SIDED WHITE/YELLOW NUMBER PLATE FOR AGRICULTURAL TRAILERS
 DOPPELSEITIGES NUMMERN Schild (WEISS/GELB) FÜR LANDWIRTSCHAFTLICHE ANHÄNGER
 TARGA REPETIDOR BIFACCIALE BLANCO / AMARILLO PARA REMOLQUES AGRÍCOLAS

Art./Ref.	Misure/Sizes	Materiale/Material
09250	165x165 mm	Alluminio/Aluminium



Lato bianco
White side

Lato giallo
Yellow side

NUMERI E LETTERE ADESIVI PER TARGHE RIPETITRICI E PANNELLI SOSTITUTIVI PROVVISORI

CHIFFRES ET LETTRES AUTOCOLLANTS POUR PLAQUES A REPETER ET POUR PANNEAUX A REMPLACER PROVISOIRES

NUMBERS AND LETTERS ADHESIVES FOR PLATES AND REPLACED - TEMPORARY PANELS

SELBSTKLEBENDE NUMMERN UND BUCHSTABEN FÜR WIEDERHOLBARE NUMMERNSCHILDER UND ERSETZENDE BEHELFSMÄSSIGE NUMMERSCHILDER

NÚMEROS Y LETRAS ADHESIVAS PARA CHAPAS Y CUADROS SUBSTITUTIVOS PROVISIONALES

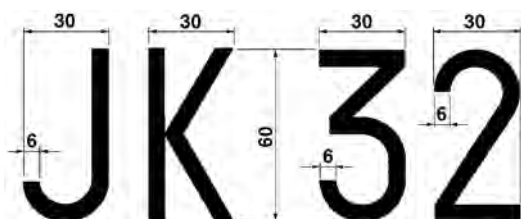

Art./Ref.	Lettera/Letter	Numero/Numero
09260	A	
09261	B	
09262	C	
09263	D	
09264	E	
09265	F	
09266	G	
09267	H	
37346	I	
09268	J	
09269	K	
09270	L	
09271	M	
09272	N	
37347	O	
09273	P	
37348	Q	
09274	R	
09275	S	
09276	T	
37349	U	
09277	V	
09278	W	
09279	X	
09280	Y	
09281	Z	
09251		1
09252		2
09253		3
09254		4
09255		5
09256		6 e 9
09257		7
09258		8
09259		0

TRIANGOLO DI SEGNALAZIONE VEICOLO FERMO CON ASTUCCIO
TRIANGLE DE PRE-SIGNALISATION
WARNING TRINAGLE WITH CASE
PANNENDREIECK
TRIÁNGULO DE SEÑALIZACIÓN DE VEÍCULO PARADO

Art./Ref.	Misure/Sizes
04035	430x65x35mm

AVVISATORE EMERGENZA
AVERTISSEUR EMERGENCE
EMERGENCY HORN
NOTFALL-HUPE
AVISADOR EMERGENCIA

Art./Ref.	Note/Note
56728	Bombola da 300 ml/Cylinder 300 ml

1.8.6 Prese e spine

Plugs



Ricambi & accessori per macchine agricole

SPARE PARTS & ACCESSORIES FOR AGRICULTURAL MACHINE

Tutti gli articoli della presente sezione, prodotti da AMA SPA e/o da terzi per conto di AMA, sono adattabili ("non originali") alle marche indicate ai sensi di quanto previsto dal REG. CE n. 1400/2002. I diritti sui marchi citati appartengono ai legittimi proprietari ed il loro uso ha l'esclusiva finalità di consentire all'utilizzatore la comparazione dei diversi prodotti. All items of this section, manufactured by AMA SPA and/or any third party on behalf of AMA, are adaptable ("non-original") to the brands listed under the provisions of the REG. CE n. 1400/2002. The rights on the trademarks belong to their respective owners and their usage is only aimed to allow the user to compare different products.

PRESE UNIPOLARI E BIPOLARI AD INCASSO

PRISES UNIPOLAIRES ET BI-POLAIRES
HANDLAMP SOCKETS 1-2- PIN
HANDLAMPEN STECKVERBINDER 1-2-POLIG
ENCHUFES UNIPOLARES HEMBRAS DE ENCAJE



Note:
6-24V
16A
Connessione a terminale 6,3 mm
ISO 4165

Notes:
6-24V
16A
6,3mm flat terminal
ISO 4165

Art./Ref.	Modello/Model	Volt/Volt	Materiale/Material	Dati tecnici/Dati tecnici	Note/Note	Brand	Rif. Orig./Orig. Ref.
02947	Unipolare	6-24V	Metallo/Metal	Connessione a faston 6,3 mm	Senza cappuccio/Without cover	-	-
02949	Unipolare	6-24V	Metallo/Metal	Connessione a faston 6,3 mm	Con cappuccio/With cover	-	-
02948	Bipolare	6-24V	Plastica/Plastic	Connessione a faston 6,3 mm	Senza cappuccio/Without cover	-	-
02924	Bipolare	6-24V	Plastica/Plastic	Connessione a faston 6,3 mm	Con cappuccio/With cover	FIAT - NEW HOLLAND - FORD	4182462, 5160258, 5160258

SPINA A 2 POLI

FICHE A 2 BROCHES
2 PIN PLUG
2-POLIG STECKER
CLAVIJA 2 POLOS



Art./Ref.	Modello/Model	Volt/Volt	Materiale/Material	Dati tecnici/Dati tecnici	Note/Note
02925	2 poli / 2 plugs	12V	Plastica/Plastic	contatti serrafile/screw terminal	ISO 4165

PRESA A 2 VIE

PRISE A 2 VOIES
FEMALE 2 PLUGS
2-POLIGER-STECKDOSE
ENCHUFE HEMBRA CON 2 VÍAS



Art./Ref.	Modello/Model	Volt/Volt	Materiale/Material	Note/Note
02926	2 vie / 2 plugs	12V	Alluminio/Aluminium	contatti serrafile/screw terminal

SPINA A 2 VIE

FICHE A 2 VOIES
 MALE 2 PLUGS
 2-POLIGER-STECKER
 ENCHUFE MACHO CON 2 VÍAS



Art./Ref.	Modello/Model	Volt/Volt	Materiale/Material
02927	2 vie/2 plugs	12/24 V	Plastica/Plastic

PRESA A 2 VIE

PRISE A 2 VOIES
 FEMALE 2 PLUGS
 2-POLIGER-STECKDOSE
 ENCHUFE HEMBRA CON 2 VÍAS



Art./Ref.	Modello/Model	Volt/Volt	Materiale/Material	Brand	Rif. Orig./Orig. Ref.
02928	2 vie/2 plugs	12/24 V	Plastica/Plastic	SAME LAMBORGHINI HURLIMANN - FIAT	4176841, 5119306, 2.6032.011.0

PRESE E SPINE 3 POLI

PRISES & FICHES 3 BROCHES
 3 PINS SOCKETS & PLUGS
 3-POLIG STECKDOSEN & STECKER
 BASE Y CLAVIJAS 3 POLOS



1



2



3

Art./Ref.	Pos.	Modello/Model	Volt/Volt	Brand	Applicazione/Application	Rif. Orig./Orig. Ref.
16525	1	Preso 3 poli 3/Pole socket	12-24V	-	-	-
16524	2	Spina 3 poli /3 Pole plug	12-24V	-	-	-
26957	3	Preso 3 poli /3 Pole socket	12-24V	NEW HOLLAND - FORD	4635, 4835, 5635, 6635, 7635, L60, L65, L75, L85, L95, T4.55, T4.65, T4.75, T4020, T4020V, T4030, T4030F, T4030N, T4030V, T4040, T4040F, T4040N, T4040V, T4050, T4050F, T4050N, T4050V, T4060F, T4060V, T5.105, T5.115, T5.95, T5030, T5040, T5050, T5060, T5070, T7510, T7520, T7530, T7540, T7550, TL100, TL100A, TL65, TL70, TL70A, TL80, TL80A, TL90, TL90A, TN55, TN55D, TN55S, TN55V, TN60A, TN60DA, TN60SA, TN60VA, TN65, TN65D, TN65F, TN65N, TN65S, TN65V, TN70, TN70A, TN70D, TN70DA, TN70F, TN70NA, TN70S, TN70SA, TN70VA, TN75, TN75A, TN75D, TN75DA, TN75F, TN75FA, TN75N, TN75NA, TN75S, TN75SA, TN75V, TN75VA, TN80F, TN85A, TN85DA, TN85FA, TN85SA, TN90F, TN95A, TN95DA, TN95F, TN95FA, TN95NA, TN95VA	5170243, 5170243

SPINA A 3 POLI 6-24V CON CAPPUCCIO

FICHE 3 POLES AVEC CAPUCHON 6-24V
 PLUG 3-PIN 6-24V WITH COVER
 STECKER 3-POLIG 6-24V
 ENCHUFE 3 VÍAS CON CAPUCHÓN



Note: DIN 9680 **Notes:** DIN 9680

Art./Ref.	Dati tecnici/Dati tecnici	Brand	Applicazione/Application	Rif. Orig./Orig. Ref.
19035	Contatti in nichel per terminali a faston, con dado per cablaggio 6-10 mm	NEW HOLLAND - FORD	8160, 8260, 8360, 8560, M100, M115, M135, M160, TS100, TS110, TS115, TS90	82013449, 82013449

PRESA A 3 POLI CON 4 FORI DI FISSAGGIO

PRISE 3 BROCHES 4 TROUS
 3 PIN SOCKET WITH 4 FIXING HOLES
 3-P STECKDOSE 4 BEFESTIGUNGSLOCHERN
 BASE 3 POLOS CON 4 ORIFICIOS DE FIJACION



Art./Ref.	Materiale/Material	Dati tecnici/Dati tecnici
19036	Plastica/Plastic	Contatti a faston

SPINA 4 POLI 6-24V

FICHE 4 BROCHES 6-24V
 4 PINS PLUG 6-24V
 4 POLIG STECKER 6-24V
 CLAVIJA 4 POLOS 6-24V



Note: Terminali serrafilo Per cavo 5.0-9.0 mm DIN 72575

Notes: Screw terminal For cable 5.0-9.0 mm DIN 72575

Art./Ref.	Materiale/Material
84427	Plastica/Plastic

PRESA 4 POLI 6-24V

PRISE 6/24V 4 BROCHES
4 PINS SOCKET 6/24V
4-POLIG KUNSTSTOFF STECKDOSE 6/24V
BASE 4 POLOS 6/24V



Note: Contatti a serrafilo DIN 72575
Notes: Screw terminal DIN 72575

Art./Ref.	Materiale/Material
84428	Plastica/Plastic

SPINE A 7 POLI 12V

FICHES 12V 7 BROCHES
7 PINS PLUGS 12V
7-POLIG STECKER 12V
CLAVIJAS 7 POLOS 12V



Note: Contatti a serrafilo ISO 1724 tipo N
Notes: Screw terminal ISO 1724 N-type

Art./Ref.	Materiale/Material
02929	Plastica/Plastic
06502	Alluminio/Aluminium

PROLUNGA CABLAGGIO 3M CON SPINE 7 VIE 12V

PROLONGATEURS 3M AVEC FICHE 7 BROCHES 12V
3M WIRING WITH 7 PINS PLUG 12V
VERBINDUNGSKABEL 3M MIT 2 STECKER 7-POLIG AIS KUNSTSTOFF
EXTENSIÓN 3M CON CLAVIJA 7 POLOS 12V



Art./Ref.	Brand	Ricambio/Replacement
12645	A.M.A.	02929 - spina 7 poli 12v in plastica / 7 pins clip-plug 12v

PROLUNGA CABLAGGIO 3M CON PRESA E SPINE 7 VIE 12V

PROLONGATEURS 3M AVEC FICHE & PRISE 7 BROCHES 12V
3M WIRING WITH 7 PINS PLUG & SOCKET 12V
VERBINDUNGSKABEL 3M MIT 1 STECKER UND 1 STECKDOSE 7-POLIG KUNSTSTOFF 12V
EXTENSIÓN 3M CON CLAVIJA E BASE 7 POLOS 12V



Art./Ref.	Brand	Ricambio/Replacement
12646	A.M.A.	02929 - spina 7 poli 12v in plastica / 7 pins clip-plug 12v, 12580 - presa volante 7 vie / female 7 pin plug plastic

PROLUNGA CAVO SPIRALATO CON SPINE 7 POLI 12V

CORDIN ELECTRIQUE AVEC FICHES 12V 7 BROCHES
COIL WITH 7 PINS PLUGS 12V
SPIRALKABEL MIT 7-POLIG KUNSTSTOFF STECKERN 12V
ESPIRAL ELECTRICA 7 POLOS 12V



Art./Ref.	Lunghezza mm/ Lenght mm	Sezione/ Section	Brand	Ricambio/Replacement
04490	3500 mm	7X1	A.M.A.	02929 - spina 7 poli 12v in plastica / 7 pins clip-plug 12v

PRESA 7 POLI 12V

PRISE 12V 7 BROCHES
7 PIN SOCKET 12V
7-P STECKDOSE 12V
BASE 7 POLOS 12V



Note: ISO 1724 TIPO N
Notes: ISO 1724 TIPO N

Art./Ref.	Dati tecnici/Dati tecnici	Materiale/Material
37342	Conttati a faston	Plastica/Plastic

PRESE 7 POLI 12V

PRISES 12V 7 BROCHES
7 PIN SOCKETS 12V
7-POLIG STECKDOSE 12V
BASES 7 POLOS 12V



Note: Contatti a serrafilo ISO 1724 tipo N
Notes: Screw terminal ISO 1724 N-type

Art./Ref.	Materiale/Material
02930	Plastica/Plastic
06501	Alluminio/Aluminium

PRESA VOLANTE 7 VIE

PRISE A 7 VOIES
FEMALE 7 PLUGS
7 - POLIGER - STECKDOSE
ENCHUFE HEMBRA CON 7 VÍAS



Art./Ref.	Materiale/Material	Volt/Volt	Note/Note
12580	Plastica/Plastic	12V	contatti serrafilo screw terminal

GUARNIZIONE POSTERIORE PER PRESA 7 POLI 12V CON ATTACCHI SERRAFILO

JOINT ARRIERE POUR PRISE 12V 7BROCHES CONTACTS A VIS
REAR PROTECTING CAP FOR 7 PINS 12V SOCKET WITH SCREW TERMINALS
HINTERE GUMMIDICHTUNG FUR STECKDOSE 7-POLIG 12V MIT SCHRAUBANSCHLUSS
GUARNICION TRASERA PARA BASE 7 POLOS 12V CONEXION DE TORNILLO



Art./Ref.	Materiale/Material	Brand	Applicazione/Application
36769	Gomma/Rubber	A.M.A.	02930, 06501

GUARNIZIONE POSTERIORE PER PRESA 7 POLI 12V CON ATTACCHI SERRAFILO

JOINT ARRIERE POUR PRISE 12V 7BROCHES CONTACTS A VIS
REAR PROTECTING CAP FOR 7 PINS 12V SOCKET WITH SCREW TERMINALS
HINTERE GUMMIDICHTUNG FUR STECKDOSE 7-POLIG 12V MIT SCHRAUBANSCHLUSS
GUARNICION TRASERA PARA BASE 7 POLOS 12V CONEXION DE TORNILLO



Art./Ref.	Materiale/Material	Brand	Applicazione/Application
04491	Gomma/Rubber	A.M.A.	02930, 06501

STAFFA PER IL FISSAGGIO DELLA PRESA 7 VIE

PLAQUE POUR PRISE 7 BROCHES
BRACKET FOR FIXING 7P SOCKET
MONTAGEWINKEL ZU STECKDOSE
AGARRE PARA BASE 7 POLOS



Art./Ref.	Brand	Applicazione/Application
03967	A.M.A.	02930, 06501

SPINA 13 POLI

PRISE 13 POLES
PLUG 13 POLES
STECKER 13-POLIG
ENCHUFE MACHO 13 P



Art./Ref.	Materiale/Material	Volt/Volt	Note/Note
51690	Plastica/Plastic	12V	contatti serrafilo / screw terminal

PRESA A 13 POLI 12V

PRISE 12V 13 BROCHES
13 PIN SOCKET 12V
13-P STECKDOSE 12V
BASE 13 POLOS 12V



Note: Contatti a serrafilo ISO 1146

Notes: Screw terminal ISO 1146

Art./Ref.	Materiale/Material
51691	Plastica/Plastic

ADATTATORE 12 V CON SPINA A 7 POLI E PRESA A 13 POLI

ADAPTATEUR 12 V AVEC PRISE 7 POLES ET PRISE 13 POLES
12 V ADAPTOR WITH 7 POLE PLUG & 13 POLE SOCKET
ADAPTER 12 V MIT 7-POLIGER-STECKER UND 13 POLIGERSTECKDOSE
ADAPTADOR 12 V CON ENCHUFE DE 7 POLOS Y TOMA DE 13 POLOS



Note: Materiale corpo: Plastica

Notes: Materiale corpo: Plastica

Art./Ref.	Materiale/Material	Volt/Volt
36771	Plastica/Plastic	12 V

ADATTATORE 12 V CON SPINA 13 POLI E PRESA A 7 POLI

ADAPTATEUR 13/7 POLES
ADAPTOR 13/7 POLES
ADAPTER 13/7 POLIG
ADAPTADOR 13/7 POLO



Art./Ref.	Materiale/Material	Volt/Volt
51689	Plastica/Plastic	12 V

ACCENDISIGARI 12V

ALLUME-CIGARE 12V
12V CIGAR LIGHTER
ZIGARETTENANZUENDER 12V
ENCENDEDOR 12V



Art./Ref.	Volt/Volt	Dima mm/Dima
58568	12V	28 mm

1.8.7 Cavo Elettrico

Electric cable



Ricambi & accessori per macchine agricole

SPARE PARTS & ACCESSORIES FOR AGRICULTURAL MACHINE

Tutti gli articoli della presente sezione, prodotti da AMA SPA e/o da terzi per conto di AMA, sono adattabili ("non originali") alle marche indicate ai sensi di quanto previsto dal REG. CE n. 1400/2002. I diritti sui marchi citati appartengono ai legittimi proprietari ed il loro uso ha l'esclusiva finalità di consentire all'utilizzatore la comparazione dei diversi prodotti. All items of this section, manufactured by AMA SPA and/or any third party on behalf of AMA, are adaptable ("non-original") to the brands listed under the provisions of the REG. CE n. 1400/2002. The rights on the trademarks belong to their respective owners and their usage is only aimed to allow the user to compare different products.

CAVI UNIPOLARI F3 IN RAME ROSSO ELETTROLITICO CU ETP1
CABLE UNIPOLARE F3 EN CUIVRE ROUGE ELECTROLYTIQUE CU ETP1
UNIPOLAR CABLE F3 RED ELECTROLYTIC COPPER CU ETP1
KABLE UNIPOLAR F3 ELEKTROLYTISCH KUPFERROT CU ETP1
CABLE UNIPOLAR F3 EN COBRE ELECTROLITICO CU ETP1

Note: Cavi flessibili unipolari con isolamento in PVC, idonei per l'impiego in bassa tensione su impianti elettrici, sistemi e componenti di autoveicoli, dove l'esposizione a fonti di calore non sono fisse sulla superficie del cavo. Sono particolarmente indicati per i cablaggi in tutte quelle zone dell'auto molto esposte a sorgenti di calore, ma non fisse sul cavo. Tensione d'esercizio <300 V Temperatura d'esercizio -40°C / + 105°C Tabella FIAT AUTO 91107/18

Notes: PVC insulated flexible single core cables that is intended for use on low voltage electrical installations, systems and components of road vehicles where the heat exposure is not continuous on cable surface. The cables are mainly intended for the wiring everywhere a frequent thermal loading, but continuously on cable, could be occurred. Max voltage <300V Use temperature -40°C / + 105°C FIAT AUTO Table 91107/18

Art./Ref.	Sezione/Section	Colore/Color	N° fili/N° wires	Bobina/Coil	Ampere/AMP
85564	1X1,00	Giallo/Yellow	32X0,20 +/- 0,01 mm	200 m	11,0 A
85565	1X1,00	Nero/Black	32X0,2 +/- 0,01 mm	200 m	11,0 A
85566	1X1,00	Rosso/Red	32X0,20 +/- 0,01 mm	200 m	11,0 A
85567	1X1,00	Grigio/Grey	32X0,20 +/- 0,01 mm	200 m	11,0 A
85568	1X1,00	Verde/Green	32X0,20 +/- 0,01 mm	200 m	11,0 A
85569	1X1,00	Giallo/Nero/Yellow/Black	32X0,20 +/- 0,01 mm	200 m	11,0 A
85570	1X1,00	Rosso/Nero/Red/Black	32X0,20 +/- 0,01 mm	200 m	11,0 A
85571	1X1,00	Bianco/White	32X0,20 +/- 0,01 mm	200 m	11,0 A
85572	1X1,50	Nero/Black	30X0,25 +/- 0,01 mm	100 m	14,0 A
85573	1X1,50	Grigio/Grey	30X0,25 +/- 0,01 mm	100 m	14,0 A
85574	1X1,50	Verde/Green	30X0,25 +/- 0,01 mm	100 m	14,0 A
85575	1X1,50	Rosso/Red	30X0,25 +/- 0,01 mm	100 m	14,0 A
85576	1X2,50	Nero/Black	50X0,25 +/- 0,01 mm	100 m	20,0 A
85577	1X2,50	Rosso/Red	50X0,25 +/- 0,01 mm	100 m	20,0 A
85578	1X2,50	Marrone/Brown	50X0,25 +/- 0,01 mm	100 m	20,0 A
85579	1X4,00	Nero/Black	56X0,30 +/- 0,01 mm	100 m	28,0 A
85580	1X4,00	Rosso/Red	56X0,30 +/- 0,01 mm	100 m	28,0 A
85581	1X4,00	Marrone/Brown	56X0,30 +/- 0,01 mm	100 m	28,0 A
85582	1X6,00	Nero/Black	84X0,30 +/- 0,01 mm	100 m	37,0 A
85583	1X6,00	Rosso/Red	84X0,30 +/- 0,01 mm	100 m	37,0 A
85584	1X6,00	Marrone/Brown	84X0,30 +/- 0,01 mm	100 m	37,0 A

CAVO ELETTRICO MULTIPOLARE A BASSA TENSIONE ISOLATO PVC

CABLE MULTI CONDUCTEURS ISOLE' PVC

MULTICORE FLEXIBLE ELECTRIC CABLES PVC ISULTAED

KABEL

CABLE ELECTRICO A BAJA TENSION MULTIPOLAR PVC CON ASLAMIENTO

**Note:** Sono cavi per impianti elettrici indicati per la posa mobile Bobina 100m**Notes:** Sono cavi per impianti elettrici indicati per la posa mobile Bobina 100m

Art./Ref.	Sezione/Section	Volt/Volt	Temperatura/Temperature	Note/Note
19643	2X0,75 mm ²	300/500 V	60 °C	H05VV-F
19160	2PX1mm ²	300/500 V	60 °C	H05VV-F
19644	2X1,50mm ²	300/500 V	60 °C	H005V-F
19645	2X2,50mm ²	300/500 V	60 °C	H05VV-F
19648	3X1,50mm ²	300/500 V	60 °C	H05VV-F
19652	4X1,50mm ²	300/500 V	60 °C	H005V-F
02957	5X1,00mm ²	300/500 V	60 °C	H005V-F
19655	5X1,50mm ²	300/500 V	60 °C	H05VV-F
02958	7X1,00mm ²	450/750V	70°C	FROR 450/750V
19659	7X1,50mm ²	450/750V	70°C	FROR 450/750V

CAVO CANDELA STANDARD

FIL DE BOUGIES STANDARD

STANDARD SPARK-PLUG CABLE

NORMALES KERZENKABEL

CABLE PARA BUJIAS STANDARD



Art./Ref.	Diametro mm/Diameter mm	Lunghezza mm/Lenght mm
01346	Ø 7mm	20 m
01388	Ø 5mm	20 m

CAVO PER SALDATRICI ISOLATO IN PVC

CABLE DE SOUDEUSE/BATTERIE ISOLE' PVC
 PVC INSULATED CABLES FOR WELDING MACHINES
 ISOLIERTES PVC-KABEL FUER SCHWEISSMASCHINEN
 CABLE DE SOLDADURA/BATERIA AISLADA PVC

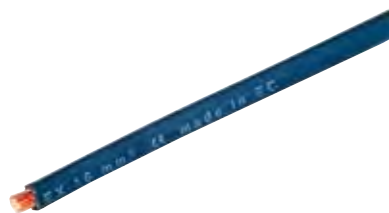

Note: Per connessioni laterali secondarie di impianti di saldatura manuali e automatici ad arco elettrico per tensione secondaria tipica delle attrezzature di saldatura. Tensione nominale 450/750V. Temperatura massima di esercizio 70°C. Matasse da 25m

Notes: For secondary side connection of powers sources for hand or automatic metal-arc welding for secondary voltage typical of welding equipment. Rated voltage 450/750V. Operating max temperature 70°C. Coil 25m

Art./Ref.	Sezione/Section	Diametro esterno mm/Outside diemter mm	Bobina/Coil
17445	1X16,00mm ²	9,2mm	25m
17446	1X35,00mm ²	12mm	25m

TUBO CORRUGATO PP-MOD

GAINES D'ISOLATION ANNELEES PP-MOD
 PP-MOD CORRUGATED TUBE
 FLEXIBER-KABELSCHUTZ PP-MOD
 TUBO CORRUGADO PP-MOD



Note: Polipropilene modificato Temp. Utilizzo: -40° + 135° (per alcune ore +150°) Idrorepellente e idrofugo Resistente agli acidi. Resistente al gelo e buona tolleranza alle torsioni Resistenza alla fiamma: FMVSS302

Notes: Polipropilene modificato Temp. Utilizzo: -40° + 135° (per alcune ore +150°) Idrorepellente e idrofugo Resistente agli acidi. Resistente al gelo e buona tolleranza alle torsioni Resistenza alla fiamma: FMVSS302

Art./Ref.	Sezione/Section	Diametro esterno mm/Outside diemter mm	Diametro interno mm/Inside diameter mm	Bobina/Coil
12594	NW 4,5mm	7,1mm	5,00mm	100m
12595	NW 7,5 mm	9,9mm	6,9mm	50m
12596	NW 8,5mm	11,6 mm	8,5mm	50m
12597	NW 10,00mm	12,7mm	10,1mm	50m
12598	NW 13,00mm	15,8mm	12,9mm	50m
12599	NW 17,00mm	21mm	16,8mm	50m
12600	NW 22,00mm	25,5mm	21,8mm	50m

1.8.8 Fari Lavoro

Work lights



Ricambi & accessori per macchine agricole

SPARE PARTS & ACCESSORIES FOR AGRICULTURAL MACHINE

Tutti gli articoli della presente sezione, prodotti da AMA SPA e/o da terzi per conto di AMA, sono adattabili ("non originali") alle marche indicate ai sensi di quanto previsto dal REG. CE n. 1400/2002. I diritti sui marchi citati appartengono ai legittimi proprietari ed il loro uso ha l'esclusiva finalità di consentire all'utilizzatore la comparazione dei diversi prodotti. All items of this section, manufactured by AMA SPA and/or any third party on behalf of AMA, are adaptable ("non-original") to the brands listed under the provisions of the REG. CE n. 1400/2002. The rights on the trademarks belong to their respective owners and their usage is only aimed to allow the user to compare different products.

FARO LAVORO AL LED (CREE) 135X120MM 10-30V 90W 8100LM

PHARE DE TRAVAIL 9 LED (CREE) 135X120MM 10-30V 90W 8100LM
 LED (CREE) WORK LIGHT 135X120MM 10-30V 90W 8100LM
 LED- ARBEITSSCHEINWERFER 9 LED (CREE) 135X120MM 10-30V 90W 8100LM
 FARO DE TRABAJO LED (CREE) 135X120MM 10-30V 90W 8100LM

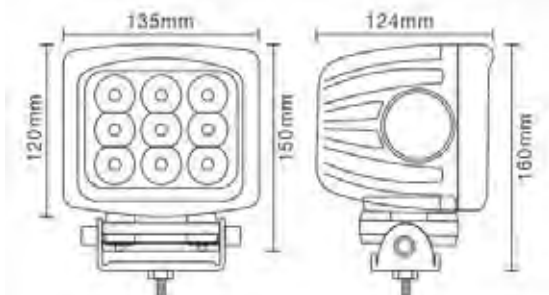

Trasparente PC
 Cablaggio 40-60 cm
 Assorbimento di corrente: 6,25A a 12V - 3,2A a 24V
 Staffa di montaggio in acciaio inossidabile
 Temperatura colore: 6000K
 Durata vita 30000 ore
 Certificati: CE, RoHS, IP67
 PC lens
 Current draw: 6,25A to 12V; 3,2A to 24V
 Color temperature: 6000K
 Life time 30000 hours
 CE, RoHS, IP67 Approval

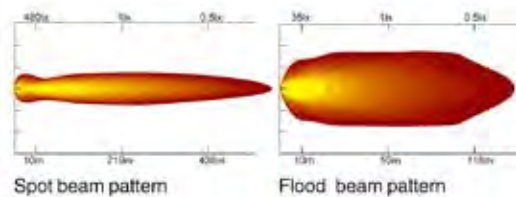

Art./Ref.	Modello/Model	Costruzione/Costruzione	Protezione IP/IP protection
OF01120	Flusso luminoso ad ampio raggio (Flood 22lx a 10M; 90°)/Flood beam (22lx a 10M; 90°)	9 LED (CREE)	IP67
OF01128	Flusso luminoso a lungo raggio (spot 500lx a 10m, 8°)/Spot beam (500lx a 10m, 8°)	9 LED (CREE)	IP68

FARO LAVORO LED (CREE) 140X165 MM 10-60V 80W 7200LM

PHARE DE TRAVAIL 8 LED (CREE) 140X165 MM 10-60V 80W 7200LM
 LED (CREE) WORK LIGHT 140X165 MM 10-60V 80W 7200LM
 LED- ARBEITSSCHEINWERFER 140X165 MM 8 LED (CREE) 10-60V 80W 7200LM
 FARO DE TRABAJO LED (CREE) 140X165 MM 10-60V 80W 7200LM

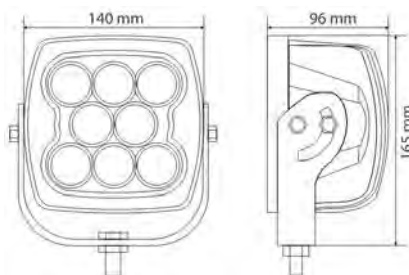

Corpo in alluminio
 Trasparente in PC
 Assorbimento di corrente: 6,1A a 12V - 2,77A a 24V
 Staffa di rotazione M10
 Elettronica integrata
 Cablaggio 41cm con connettore Deutsch
 Temperatura di esercizio: -40°C + 60°C
 Temperatura colore: 6500K Durata vita 5000 ore
 Certificati: CE RoHS
 Diecast aluminum housing
 PC lens
 Current draw: 6,1A to 12V - 2,77A to 24V
 Single M10 bolt&vertical rotation bracket
 Electronics integrated
 Cable 41 cm with Deutsch connector
 Work temperature: -40°C + 60°C Color temperature: 6500K
 Life time 5000 hours
 CE, RoHS Approved

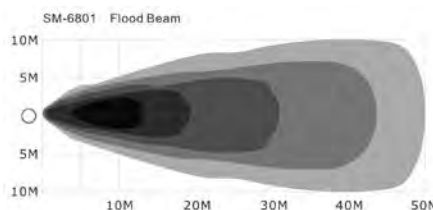

Art./Ref.	Modello/Model	Costruzione/Costruzione	Protezione IP/IP protection
OF01121	Flusso luminoso ad ampio raggio (60°)/Flood beam 60°/Flood beam (60°)	CREE LED	IP67

FARO LAVORO A LED (CREE) 127X90MM 10-30V 48W 3800LM

PHARE DE TRAVAIL 16 LED (CREE) 127X90 MM 10-30V 48W 3800LM
 LED (CREE) WORK LIGHT 127X90MM 10-30V 48W 3800LM
 LED- ARBEITSSCHEINWERFER 127X90 MM 16 LED (CREE) 10-30V 48W 3800LM
 FARO DE TRABAJO LED (CREE) 127X90MM 10-30V 48W 3800LM

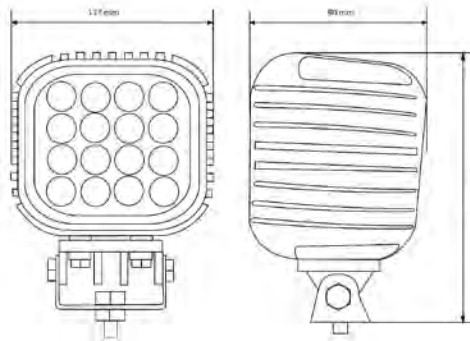

Corpo in alluminio e trasparente in vetro
 Staffa di montaggio in acciaio inossidabile
 Assorbimento corrente: 3,4A a 12V- 1,57A a 24V
 Temperatura di esercizio: -40°C; +60°C
 Certificati: CE, RoHS
 Diecast aluminum housing
 Glass lens
 Stainless steel mounting bracket
 Current draw: 3,4A a 12V- 1,57A a 24V
 Work temperature: -40°C; +60°C
 Life time: 30.000 hours
 CE, RoHS approved

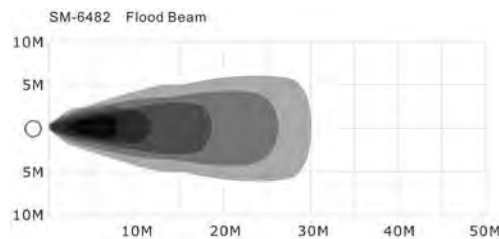

Art./Ref.	Modello/Model	Costruzione/Costruzione	Protezione IP/IP protection
0F01122	Flusso luminoso ad ampio raggio (60°)/Flood beam 60°/Flood beam 60°	CREE LED (16x3W)	IP67

FARO DA LAVORO A LED 110X110MM 10-30V 48W 3200LM

PHARE DE TRAVAIL LED 110X110MM 10-30V 48W 3200LM
 LED WORK LIGHT 110X110MM 10-30V 48W 3200LM
 LED- ARBEITSSCHEINWERFER 110X110MM 10-30V 48W 3200LM
 FARO DE TRABAJO LED 110X110MM 10-30V 48W 3200LM

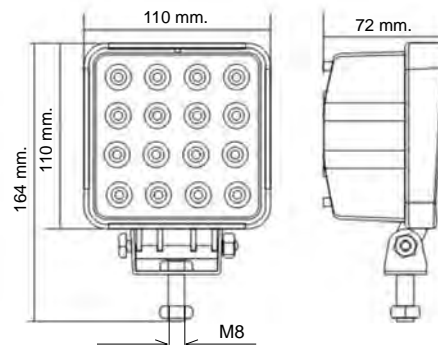

Consumo di corrente: 3,8A a 12V; 1,9A a 24V
 Temperatura colore: 6000K
 Pre-cablato: 40-60cm
 Corpo in alluminio, Lente in PC, Staffa di fissaggio in acciaio inossidabile
 30000 ore di vita
 Certificati: CE RoHS IP67
 Diecast aluminum housing, PC lens, Stainless steel mounting bracket
 Current draw: 3,8A a 12V; 1,9A a 24V
 Color temperature: 6000K
 Life time 30000 hours
 Cable 40-60cm
 CE RoHS IP67 approved

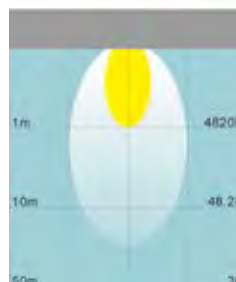

Art./Ref.	Modello/Model	Costruzione/Costruzione	Protezione IP/IP protection
0F01105	Flusso luminoso ad ampio raggio (60°)/Flood beam 60°	16 LED (Epistar)	IP 67

FARO DA LAVORO A LED 110X128MM 10-30V 24W 1440LM

PHARE DE TRAVAIL LED 110X128MM 10-30V 24W 1440LM
 LED WORK LIGHT 110X128MM 10-30V 24W 1440LM
 LED- ARBEITSSCHEINWERFER 110X128MM 10-30V 24W 1440LM
 FARO DE TRABAJO LED 110X128MM 10-30V 24W 1440LM

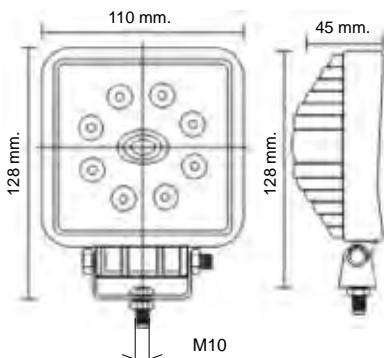

Consumo di corrente: 1,8A a 12V; 0,9A a 24V
 Temperatura colore: 6000K
 Pre-cablato: 40-60cm
 Corpo in alluminio, Lente in PC, Staffa di fissaggio in acciaio inossidabile
 30000 ore di vita
 Certificati: CE, RoHS, IP67
 Diecast aluminum housing, PC lens, Stainless steel mounting bracket
 Current draw: 1,8A to 12V; 0,9A to 24V
 Color temperature: 6000K
 Life time 30000 hours
 Cable 40-60cm
 CE, RoHS, IP67 approved

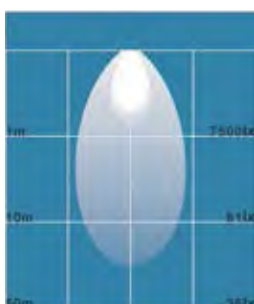

Art./Ref.	Modello/Model	Costruzione/Costruzione	Protezione IP/IP protection
OF01092	Flusso luminoso ad ampio raggio (60°)/Flood beam 60°/Flood beam (60°)	8 LED (Epistar)	IP 67

FARO LAVORO LED 104X140MM 12-24V 9W 1000LM

PHARE DE TRAVAIL LED 104X140MM 12-24V 9W 1000LM
 LED WORK LIGHT 104X140MM 12-24V 9W 1000LM
 LED- ARBEITSSCHEINWERFER 104X140MM 12-24V 9W 1000LM
 FARO DE TRABAJO LED 104X140MM 12-24V 9W 1000LM

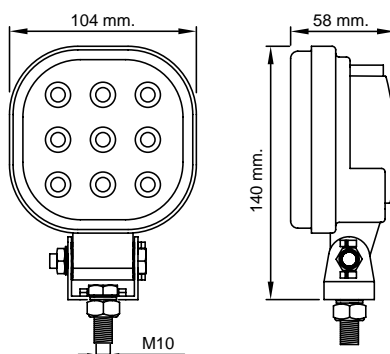

Consumo corrente: 1A a 12V; 0,42A a 24V
 Corpo in alluminio e lente in PC,
 Temperatura di esercizio -40°C a + 50°C,
 IP67 30000 ore di vita
 Certificati: CE RoHS
 Current draw 1A to 12V; 0,42A to 24V
 Aluminum housing, PC lens
 Working temperature: -40°C to + 50°C
 30000 Life time
 CE RoHS approved

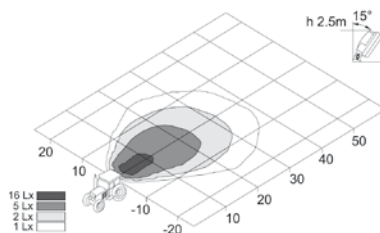

Art./Ref.	Modello/Model	Costruzione/Costruzione	Protezione IP/IP protection
OF01108	Flusso luminoso ad ampio raggio/Flood beam	9 LED	IP 67

FARO LAVORO A LED (CREE) 145X122MM 10-30V 50W 7200 LM

PHARE DE TRAVAIL 5 LED (CREE) 145X122MM 10-30V 50W 7200 LM
 LED (CREE) WORK LIGHT 145X122MM 10-30V 50W 7200 LM
 LED- ARBEITSSCHEINWERFER 145X122MM 10-30V 5 LED (CREE) 50W 7200 LM
 FARO DE TRABAJO LED (CREE) 145X122MM 10-30V 50W 7200 LM

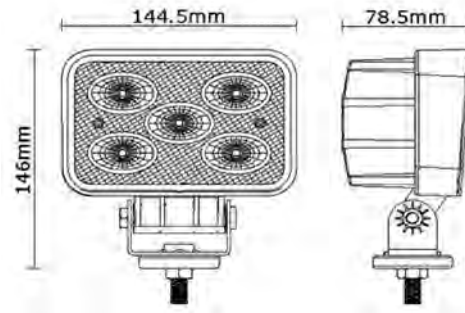

Cablaggio 40-60cm,
 Assorbimento corrente: 4,225A a 12V; 3,502A a 13,8V; 1,880A a 24V
 Temperatura colore: 6000K, Corpo in alluminio
 Lente in PC
 Cablaggio 40-60cm
 Durata vita: 30.000 ore
 Certificati: CE, RoHS

Diecast aluminum housing
 PC lens
 Current draw: 4,225A a 12V; 3,502A a 13,8V; 1,880A a 24V,
 Cable 40-60cm
 Color temperature: 6000K,
 Life time 30000 hours
 Flood beam (120°)
 CE RoHS Approval

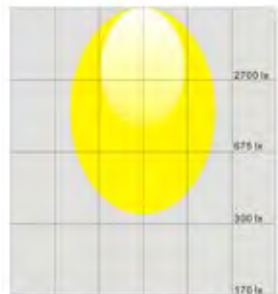

Art./Ref.	Modello/Model	Costruzione/Costruzione	Protezione IP/IP protection
OF01118	Flusso luminoso ad ampio raggio (120°)	5 LED CREE	IP 67

FARO DA LAVORO A LED 110X60MM 10-30V 18W 1080LM

PHARE DE TRAVAIL LED 110X60MM 10-30V 18W 1080LM
 LED WORK LIGHT 110X60MM 10-30V 18W 1080LM
 LED- ARBEITSSCHEINWERFER 110X60MM 10-30V 18W 1080LM
 FARO DE TRABAJO LED 110X60MM 10-30V 18W 1080LM

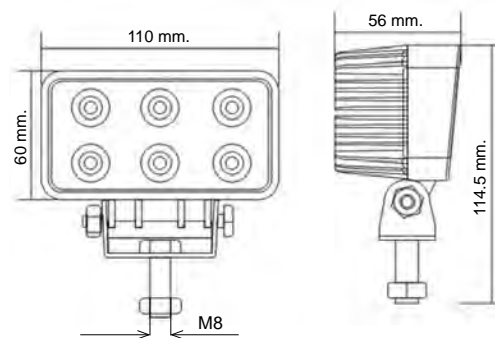

Consumo di corrente: 1,4A a 12V; 0,75A a 24V
 Temperatura colore: 6000K
 Pre-cablato: 40-60cm
 Corpo in alluminio, Lente in PC, Staffa di fissaggio in acciaio inossidabile
 30000 ore di vita
 Certificati: E-mark, CE, RoHS, IP67

Diecast aluminum housing, PC lens, Stainless steel mounting bracket
 Current draw: 1,4A to 12V; 0,75A to 24V
 Color temperature: 6000K
 Life time 30000 hours
 Cable 40-60cm
 E-mark CE RoHS IP67



Art./Ref.	Modello/Model	Costruzione/Costruzione	Protezione IP/IP protection
OF01103	Flusso luminoso ad ampio raggio (60°)/Flood beam 60°	6 LED (Epistar)	IP 67

FARO LAVORO A LED 150X112MM 9-56V 18W 600LM

PHARE DE TRAVAIL LED 150X112MM 9-56V 18W 600LM
 LED WORK LIGHT 150X112MM 9-56V 18W 600LM
 LED- ARBEITSSCHEINWERFER 150X112MM 9-56V 18W 600LM
 FARO DE TRABAJO LED 150X112MM 9-56V 18W 600LM

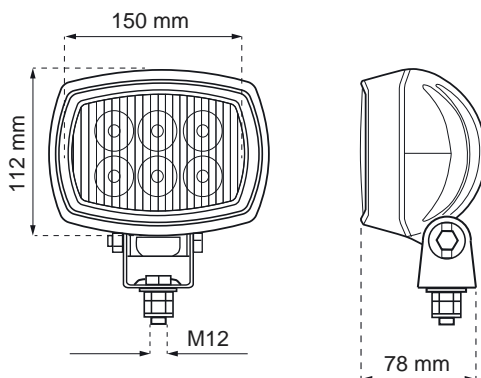

Precabato 2000mm
 Temperatura colore: 5000-6500K, Corpo in nylon stabilizzato e lente in PC
 Temperatura di esercizio: -20°C a + 60°C
 Consumo corrente 1A a 12V- 0,55A a 24V
 Certificati: CE
 Cable 2000mm
 Nylon stabilized housing and PC lens
 Working temperature -20°C a + 60°C
 Color Temperature: 500-6500K Current Draw 1A a 12V- 0,55A a 24V
 CE approved

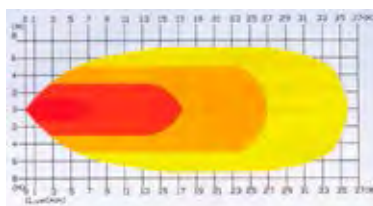

Art./Ref.	Modello/Model	Costruzione/Costruzione	Protezione IP/IP protection
0F01087	Flusso luminoso ad ampio raggio (60°)/Flood beam 60°	6 LED	IP66

FARO LAVORO LED 52X72MM 10-80V 5W 1200LM

PHARE DE TRAVAIL LED 52X72MM 10-80V 5W 1200LM
 LED WORK LIGHT 52X72MM 10-80V 5W 1200LM
 LED- ARBEITSSCHEINWERFER 52X72MM 10-80V 5W 1200LM
 FARO DE TRABAJO LED 52X72MM 10-80V 5W 1200LM

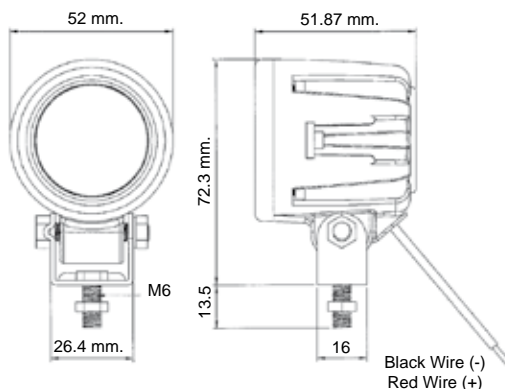

Consumo corrente: 0,36A a 12V,
 Corpo in alluminio e lente in PC,
 Temperatura di esercizio -20°C a + 60°C,
 Pre cablato 30cm,
 Colore temperatura: 6000-7000K Certificati: CE RoHS
 Current draw 0,36A to 12V,
 Aluminum housing,
 PC lens,
 Working temperature: -20°C to + 60°C, Pre-wired with 30cm cable,
 Temperature color: 5000-6000k
 CE RoHS approved

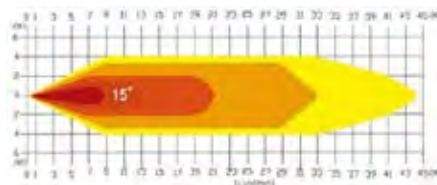

Art./Ref.	Modello/Model	Costruzione/Costruzione	Protezione IP/IP protection
0F01110	Flusso luminoso a lungo raggio (15°)	1 LED (CREE)	IP 67

FARO LAVORO A LED (EPSITAR) 116X137,5MM 10-30 V 42W 2500LM

PHARE DE TRAVAIL 14 LED (EPSITAR) 116X137,5MM 10-30 V 42W 2500LM
 LED (EPSITAR) WORK LIGHT 116X137,5MM 10-30 V 42W 2500LM
 LED- ARBEITSSCHEINWERFER 116X137,5MM 10-30 V 42W 2500LM 14 LED (EPSITAR)
 FARO DE TRABAJO LED (EPSITAR) 116X137,5MM 10-30 V 42W 2500LM

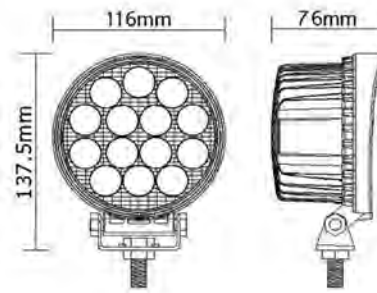

Corpo in alluminio e trasparente in PC,
 Consumo di corrente: 2,856A a 12V- 2,243A a 13,8V- 1,601A a 24V,
 Temperatura colore 6000K,
 Cablaggio 40-60 cm Staffa di fissaggio in acciaio inox,
 Durata vita: 30000 ore
 Certificati: CE, RoHS
 Diecast aluminum housing,
 PC lens,
 Current draw: 2,856A to 12V- 2,243A to 13,8V- 1,601A to 24V,
 Cable 40-60cm,
 Color temperature: 6000K,
 Life time 30000 hours
 CE RoHS approval

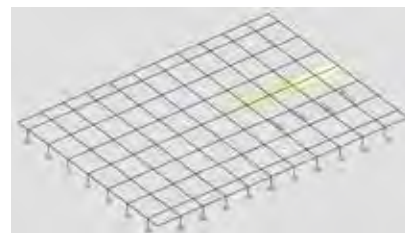

Art./Ref.	Modello/Model	Costruzione/Costruzione	Protezione IP/IP protection
OF01117	Flusso luminoso ad ampio raggio (60°)/Flood beam 60°	14 LED Epistar	IP 67

FARO LAVORO A LED (CREE) ROTONDO 155X155MM 10-60V 70W 7000LM

PHARE DE TRAVAIL 7 LED (CREE) 155X155MM 10-60V 70W 7000LM
 ROUND LED (CREE) WORK LIGHT 155X155MM 10-60V 70W 7000LM
 LED- ARBEITSSCHEINWERFER 155X155MM 7 LED (CREE) 10-60V 70W 7000LM
 FARO DE TRABAJO LED (CREE) 155X155MM 10-60V 70W 7000LM

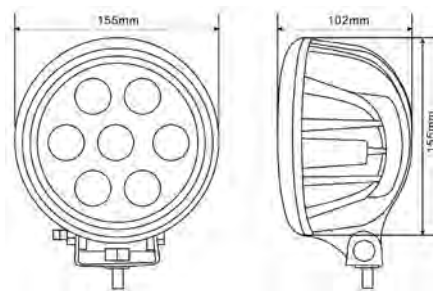

Consumo di corrente: 5,84A a 12V - 2,9A a 24V
 Corpo in alluminio e lente in PC
 Cablaggio 46 cm con connettore Deutsch
 IP67
 Certificati: CE, RoHS
 Current draw: 5,84A a 12V - 2,9A a 24V
 Aluminum Housing,
 PC Lens,
 Cable 46cm with Deutsch connector
 CE, RoHS approval

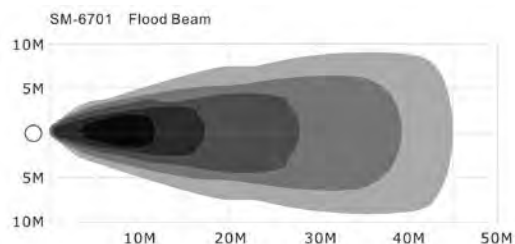

Art./Ref.	Modello/Model	Costruzione/Costruzione	Protezione IP/IP protection
OF01123	Flusso luminoso ad ampia portata (30°)/30° Flood Beam	7 LED (CREE)	IP67

FARO DA LAVORO A LED TONDO 110X128MM 10-30V 24W 1440LM

PHARE DE TRAVAIL LED 110X128MM 10-30V 24W 1440LM
 LED WORK LIGHT 110X128MM 10-30V 24W 1440LM
 LED- ARBEITSSCHEINWERFER 110X128MM 10-30V 24W 1440LM
 FARO DE TRABAJO LED 110X128MM 10-30V 24W 1440LM

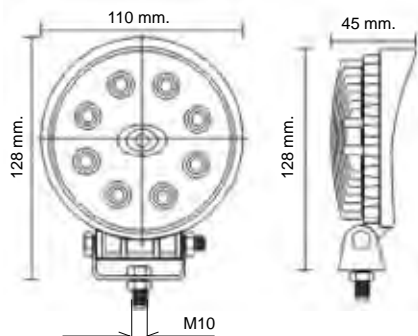

Consumo di corrente: 1,8A a 12V; 0,9A a 24V
 Temperatura colore: 6000K
 Pre-cablato: 40-60cm
 Corpo in alluminio, Lente in PC,
 Staffa di fissaggio in acciaio inossidabile
 30000 ore di vita
 Certificati: CE, RoHS, IP67
 Diecast aluminum housing,
 PC lens,
 Stainless steel mounting bracket
 Current draw: 1,8A to 12V; 0,9A to 24V
 Color temperature: 6000K
 Life time 30000 hours
 Cable 40-60cm
 CE, RoHS, IP67 approved



Art./Ref.	Modello/Model	Costruzione/Costruzione	Protezione IP/IP protection
OF01091	Flusso luminoso ad ampio raggio (60°)/Flood beam 60°	8 LED (Epistar)	IP 67

FARO LAVORO A LED 118X152MM 12-28V 18W 1350 LM

PHARE DE TRAVAIL LED 118X152MM 12-28V 18W 1350 LM
 LED WORK LIGHT 118X152MM 12-28V 18W 1350 LM
 LED- ARBEITSSCHEINWERFER 118X152MM 12-28V 18W 1350 LM
 FARO DE TRABAJO LED 118X152MM 12-28V 18W 1350 LM

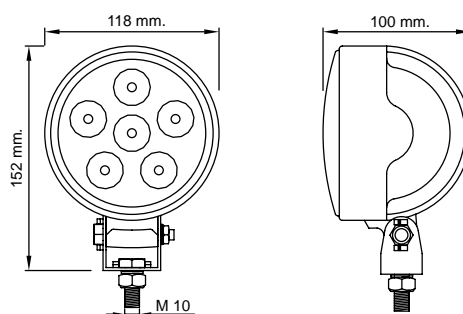

Consumo corrente: 0,9A a 12V; 0,48A a 24V
 Corpo in alluminio e lente in PC,
 Temperatura di esercizio -40°C a + 50°C
 Certificati: CE RoHS
 Current draw 0,9A to 12V; 0,48A to 24V
 Aluminum housing,
 PC lens Working temperature: -40°C to + 50°C
 CE RoHS approved

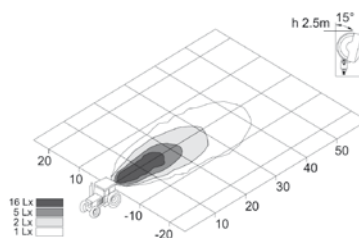

Art./Ref.	Modello/Model	Costruzione/Costruzione	Protezione IP/IP protection
OF01107	Flusso luminoso ad ampio raggio	6 LED	IP 67

FARO LAVORO A LED 83X114MM 12-24V 12W 720LM

PHARE DE TRAVAIL LED 83X114MM 12-24V 12W 720LM
 LED WORK LIGHT 83X114MM 12-24V 12W 720LM
 LED- ARBEITSSCHEINWERFER 83X114MM 12-24V 12W 720LM
 FARO DE TRABAJO LED 83X114MM 12-24V 12W 720LM

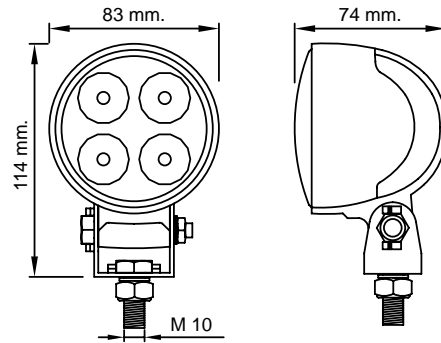

Consumo corrente: 0,65A a 12V; 0,35A a 24V
 Corpo in alluminio e lente in PC,
 Temperatura di esercizio -40°C a + 50°C
 Certificati: CE RoHS
 Current draw 0,65A to 12V; 0,35A to 24V
 Aluminum housing, PC lens
 Working temperature: -40°C to + 50°C
 CE RoHS approved

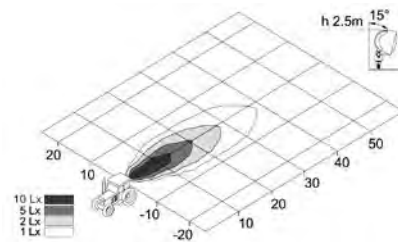

Art./Ref.	Modello/Model	Costruzione/Costruzione	Protezione IP/IP protection
0F01106	Flusso luminoso ad ampio raggio/ Flood beam	4 LED	IP 67

FARO LAVORO A LED OVALE 165X113,5MM 10-30V 65W 5850LM

PHARE DE TRAVAIL LED 165X113,5MM 10-30V 65W 5850LM
 OVAL LED WORK LIGHT 165X113,5MM 10-30V 65W 5850LM
 LED- ARBEITSSCHEINWERFER 165X113,5MM 10-30V 65W 5850LM
 FARO DE TRABAJO LED 165X113,5MM 10-30V 65W 5850LM

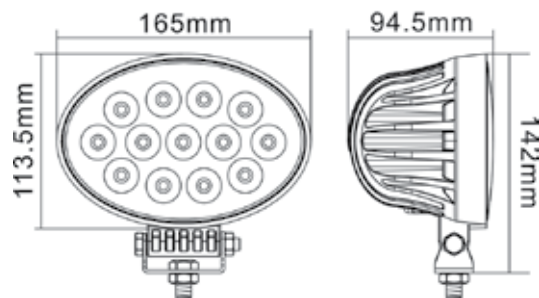

Corpo in alluminio e lente in PC,
 Consumo corrente: 3,92A a 12V; 1,99A a 24V
 Temperatura colore 6000K
 Pre-cablato 40-60cm
 Certificati: CE RoHS IP67
 Aluminum housing and PC lens
 Current draw: 3,92A to 12V; 1,99A to 24V
 Color temperature 6000K
 Cable 40-60cm
 CE RoHS IP67 approved

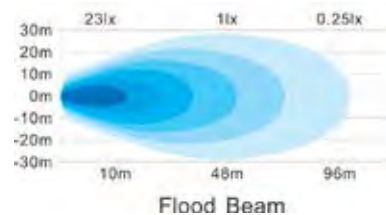

Art./Ref.	Modello/Model	Costruzione/Costruzione	Protezione IP/IP protection
0F01129	Flusso luminoso ad ampia portata (90°)	13 LED (CREE)	IP67

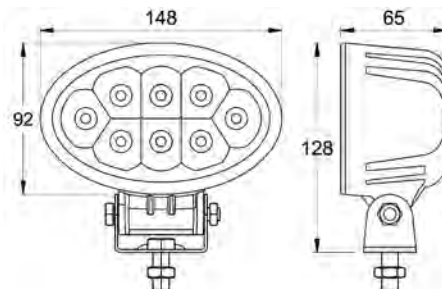
FARO LAVORO A LED OVALE 148X92MM 12-28V 24W 1800LM
PHARE DE TRAVAIL LED 148X92MM 12-28V 24W 1800LM
OVAL LED WORK LIGHT 148X92MM 12-28 V 24W 1800LM
LED- ARBEITSSCHEINWERFER 148X92MM 12-28V 24W 1800LM
FARO DE TRABAJO LED 12/28V 148X92MM 12-28V 24W 1800LM

Corpo in alluminio e trasparente in PC
 Temperatura di esercizio -40°C a + 50°C
 Resistenza agli shock 20g
 Certificati: CE, RoHS

Aluminium housing

PC lens

Working temperature -40°C a + 50°C

Shock resistance 20g

CE, RoHS approved

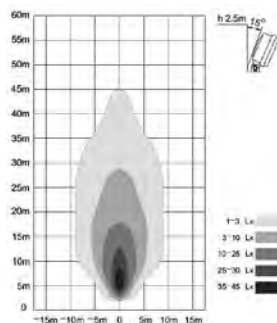

Art./Ref.	Modello/Model	Costruzione/Costruzione	Protezione IP/IP protection
OF01115	Flusso luminoso a lunga portata	8 LED	IP 67

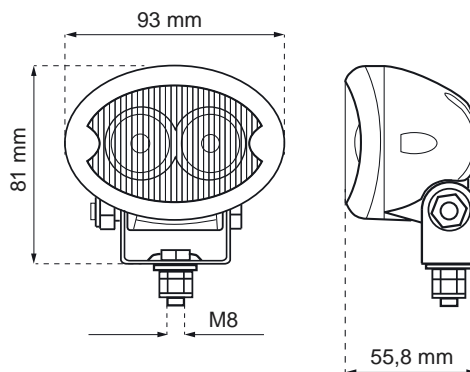
FARO LAVORO A LED 93X81MM 9-56V 6W 250LM
PHARE DE TRAVAIL LED 93X81MM 9-56V 6W 250LM
LED WORK LIGHT 93X81MM 9-56V 6W 250LM
LED- ARBEITSSCHEINWERFER 93X81MM 9-56V 6W 250LM
FARO DE TRABAJO LED 93X81MM 9-56V 6W 250LM

Precablato 2000mm Temperatura colore: 5000-6500K,

Corpo in nylon stabilizzato e lente in PC

Temperatura di esercizio: -20°C a + 60°C

Consumo corrente 1A a 12V- 0,55A a 24V

Certificati CE

Cable 2000mm

Nylon stabilized housing and PC lens

Working temperature -20°C a + 60°C

Color Temperature: 500-6500K Current Draw 1A a 12V- 0,55A a 24V

CE approved

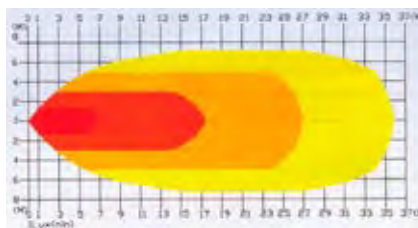

Art./Ref.	Modello/Model	Costruzione/Costruzione	Protezione IP/IP protection
OF01088	Flusso luminoso ad ampio raggio (60°)/Flood beam 60°	2 LED	IP66

BARRA LUCI A LED 118X90 MM 12-28V 18W 1350LM

BARRE LUMINEUSE A LED 118X90 MM 12-28V 18W 1350LM
 LED LIGHT BAR 118X90 MM 12-28V 18W 1350LM
 LED-LEUCHTBALKEN 118X90 MM 12-28V 18W 1350LM
 BAR DE LUZ A LED 118X90 MM 12-28V 18W 1350LM

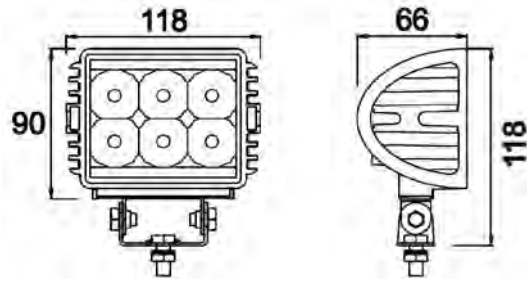

Cablaggio in uscita 40 cm
 Corpo in alluminio e lente in PC Staffa di montaggio in acciaio inox
 Assorbimento corrente: 1,12A to 12V; 0,58A to 24V
 Resistenza agli shock 20g
 Certificati: CE, RoHS
 Cable 40 cm
 Aluminum housing PC lens, Stainless steel mounting bracket Working temperature: -40°C to +50°C
 Current draw: 1,12A to 12V; 0,58A to 24V
 Shock resistance 20g
 CE RoHS approved

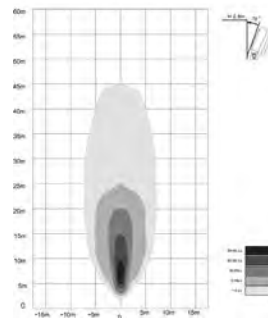

Art./Ref.	Modello/Model	Protezione IP/IP protection
84376	Flusso luminoso a lunga portata/Spot beam	IP67

BARRA LUCI A LED 200X90 MM 12-28V 36W 2700LM

BARRE LUMINEUSE A LED 200X90MM 12-28V 36W 2700LM
 LED LIGHT BAR 200X90 MM 12-28V 36W 2700LM
 LED-LEUCHTBALKEN 200X90MM 12-28V 36W 2700LM
 BAR DE LUZ A LED 200X90MM 12-28V 36W 2700LM

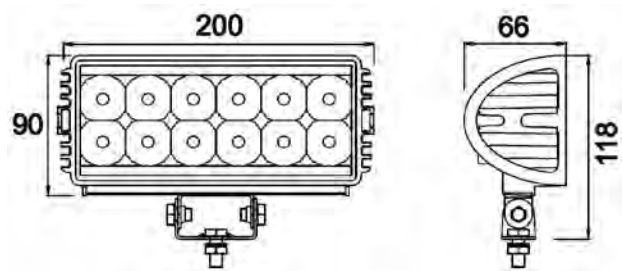

Corpo in alluminio
 Lente in PC
 Staffa di montaggio in acciaio inox
 Resistenza agli shock 20g
 Assorbimento corrente: 1,95A a 12V ; 1,05 a 24V
 Temperatura di esercizio: -40°C / + 50°C
 Omologazione: CE e RoHS
 Aluminium housing
 PC lens
 Stainless steel mounting bracket, Shock resistance 20g
 Current draw: 1,95A to 12V ; 1,05 to 24V
 Working temperature: -40°C to +50°C
 CE, RoHS approved

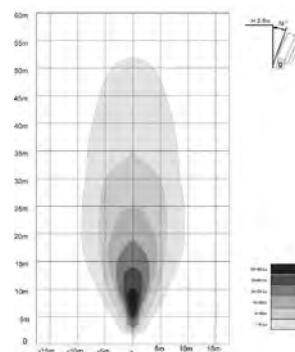

Art./Ref.	Modello/Model	Costruzione/Costruzione	Protezione IP/IP protection
84027	Flusso luminoso a lunga portata/Spot beam	12 LED (Epistar)	IP 67

BARRA LUCI A LED 536X58MM 12-28V 54W 4050LM

BARRE LUMINEUSE A LED 536X58MM 12-28V 54W 4050LM
 LED LIGHT BAR 536X58MM 12-28V 54W 4050LM
 LED-LEUCHTBALKEN 536X58MM 12-28V 54W 4050LM
 BAR DE LUZ A LED 536X58MM 12-28V 54W 4050LM

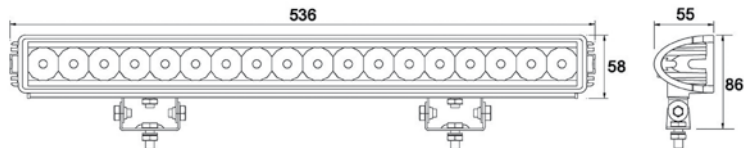

Corpo in alluminio e lente in policarbonato
 Staffa di montaggio in acciaio inox
 Resistenza agli shock 20g Cabalggio 40cm
 Consumo corrente: 2,6A a 12V; 1,35A a 24V
 Temperatura di esercizio -40°C a 50°C
 Certificazioni: CE, RoHS

*Aluminium housing and PC lens Stainless steel mounting bracket,
 Shock resistance 20g
 Cable 40cm
 Current draw: 2,6A a 12V; 1,35A a 24V
 Working temperature -40°C a 50°C
 CE, RoHS approved*

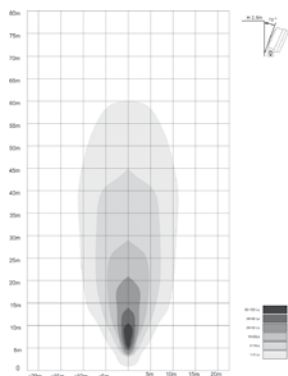

Art./Ref.	Modello/Model	Costruzione/Costruzione	Protezione IP/IP protection
84377	Flusso luminoso a lunga portata	18 LED (Epistar)	IP 67

FARO LAVORO ALOGENO 100X100MM

PHARE DE TRAVAIL 100X100MM
 HALOGEN WORK LAMP 100X100MM
 HALOGENARBEITSSCHEINWERFER 100X100MM
 FARO DE TRABAJO 100X100MM

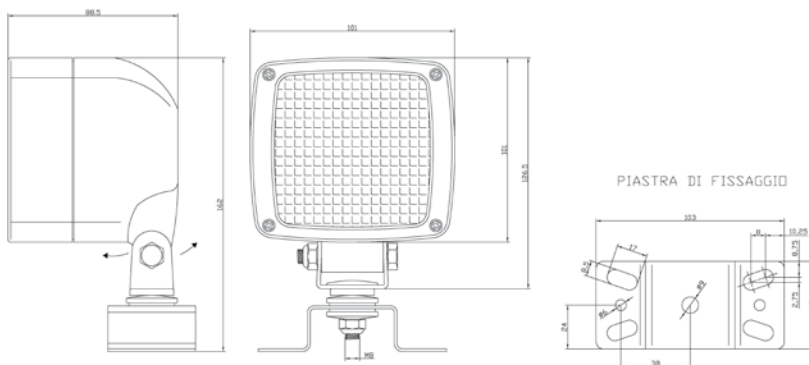

Staffa a omega, Orientabile, Connettore AMP,
 Lampadina non inclusa
 Art. 00299 H3 12V 55W (PK22S)
 Art. 00446 H3 24V 70W (PK22S)

*Omega bracket, Twist-and-tilt mounting bracket, housing with waterproof AMP connector,
 Bulb not included
 Pn 00299 H3 12V 55W (PK22S)
 Pn 00446 H3 24V 70W (PK22S)*

Art./Ref.	Corpo/Body	Trasparente/Transparent	Flusso luminoso/Luminous flux
17685	ABS	Vetro/Glass	Ad ampio raggio/Wide beam range

FARO LAVORO ALOGENO 100X100MM CON MANIGLIA

PHARE DE TRAVAIL 100X100MM AVEC POIGNEE
 HALOGEN WORK LAMP 100X100MM WITH HANDLE
 HALOGENARBEITSSCHEINWERFER 100X100MM MIT GRIFF
 FARO DE TRABAJO 100X100MM CON MANILLA

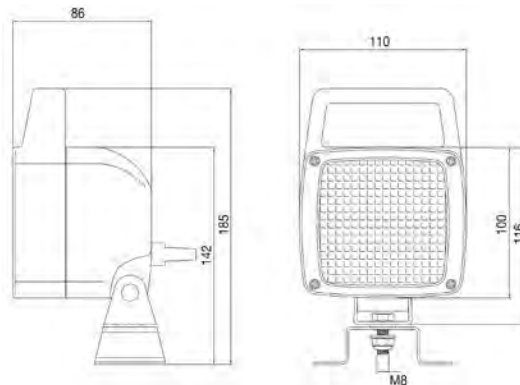

Staffa a omega, Orientabile, Connettore AMP,
 IP66 Lampadina non inclusa
 Art. 00299 H3 12V 55W (PK22S)
 Art. 00446 H3 24V 70W (PK22S)

Omega bracket, Twist-and-tilt mounting bracket, housing with waterproof AMP connector,
 IP66, Bulb not included
 Pn 00299 H3 12V 55W (PK22S)
 Pn 00446 H3 24V 70W (PK22S)

Art./Ref.	Modello/Model	Corpo/Body	Trasparente/Transparent	Flusso luminoso/Luminous flux	Brand	Ricambio/Replacement
17688	Con maniglia/With handle	ABS	Vetro/Glass	Ad ampio raggio/Wide beam range	-	-
17691	Con maniglia, base magnetica e cavo spiralato 3,5m/With handle, magnet and coil 3,5m	ABS	Vetro/Glass	Ad ampio raggio/Wide beam range	A.M.A.	02590 - CAVO CON SPINOTTO / ELECTRICAL PLUG AND WIRE, 02591 - SPINOTTO PER ACCENDISIGARI / ELECTRICAL PLUG

FARO LAVORO ALOGENO 124X124MM

PHARE DE TRAVAIL 124X124MM
 HALOGEN WORK LIGHT 124X124MM
 ZUSSATZSCHEINWERFER 124X124MM
 FARO DE TRABAJO ALOGENO 124X124MM

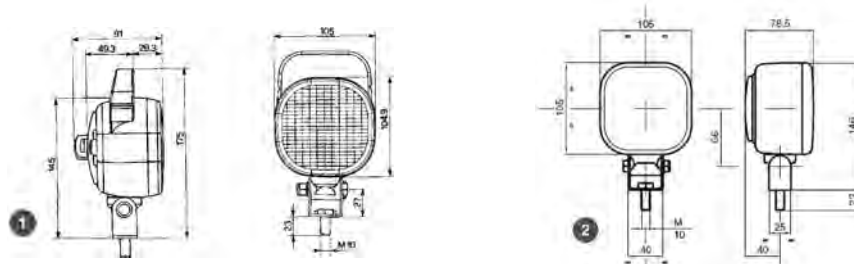

IP 67, Orientabile, Lampadina non inclusa
 Art. 00299 H3 12V 55W (PK22S)
 Art. 00446 H3 24V 70W (PK22S)
 IP67, Bulb not included,
 Pn 00299 H3 12V 55W (PK22S)
 Pn 00446 H3 24V 70W (PK22S)

Art./Ref.	Modello/Model	Corpo/Body	Trasparente/Transparent	Flusso luminoso/Luminous flux
03943	Senza maniglia/Without handle	ABS	Vetro/Glass	Ad ampio raggio/Wide beam range
27241	Con maniglia/With handle	ABS	Vetro/Glass	Ad ampio raggio/Wide beam range

FARO LAVORO ALOGENO RETTANGOLARE 138X78MM

PHARE DE TRAVAIL RECTANGULAIRE 138X78MM
 RECTANGULAR HALOGEN WORK LAMP 138 X 78MM
 RECHTECLIGE HALOGENARBEITSSCHEINWERFER 138X78MM
 FARO DE TRABAJO RECTANGULAR 138X78MM

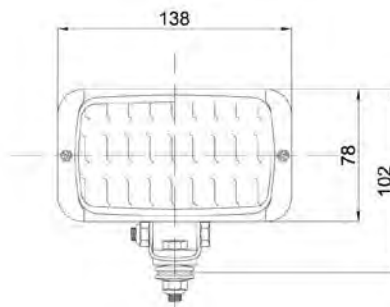
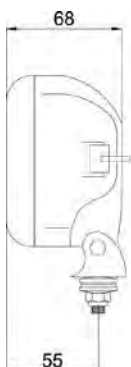

Lampadina art. 00299 H3 12V 55W inclusa,
 IP 65,
 staffa di montaggio con viti,
 cablaggio 150mm con faston 6,3 mm
*Bulb Pn 00299 H3 12V 55W included,
 IP 65 mm,
 mounting bracket with screws,
 cable terminated with F/6,3 terminals*

Art./Ref.	Corpo/Body	Trasparente/Transparent	Flusso luminoso/Luminous flux
59775	ABS	Vetro/Glass	Raggio a lunga portata/Long range beam

FARO LAVORO ALOGENO 154X128MM

PHARE DE TRAVAIL 154X128MM
 HALOGEN WORK LIGHT 154X128MM
 HALOGENARBEITSSCHEINWERFER 154X128MM
 FARO DE TRABAJO 154X128MM

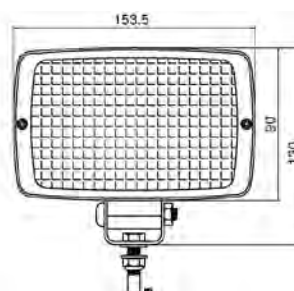
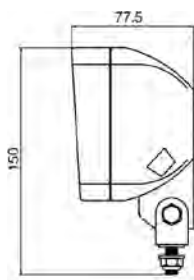

IP54
 Lampadina non inclusa
 Art.00299 H3 12V 55W (PK22S)
 Art. 00446 H3 24V 70W (PK22S)
 Adattabile a : KRAMER,LIEBHERR,MAN,O&K,STEYER,VOLVO
 IP54
*Bulb not included
 Pn.00299 H3 12V 55W (PK22S)
 Pn. 00446 H3 24V 70W (PK22S)
 Adaptable to: KRAMER,LIEBHERR,MAN,O&K,STEYER,VOLVO*

Art./Ref.	Corpo/Body	Trasparente/Transparent	Flusso luminoso/Luminous flux	Modello/Model
35894	ABS	Vetro/Glass	Ad ampio raggio/ 130 ° Orizzont. / 90° Verticale	HELLA 1GA 006 876-001

FARO LAVORO ALOGENO 168X100MM

PHARE DE TRAVAIL RECTANGULAIRE 168X100MM
 HALOGEN WORK LAMP 168X100MM
 RECHTECLIGE HALOGENARBEITSSCHEINWERFER 168X100MM
 FARO DE TRABAJO RECTANGULAR 168X100MM

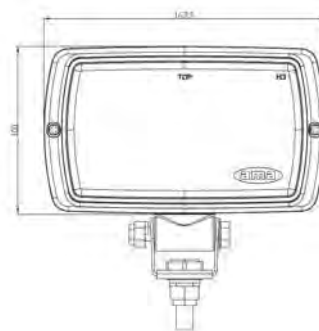

ABS e vetro
 Staffa orientabile
 Flusso a lungo raggio
 Lampadina non inclusa
 Art.00299 H3 12V 55W (PK22S) Art. 00446 H3 24V 70W (PK22S)
 ABS and glass lens,
 Long range beam
 Bulb not included
 Pn.00299 H3 12V 55W (PK22S)
 Pn. 00446 H3 24V 70W (PK22S)

Art./Ref.	Modello/Model
0F01072	Senza maniglia e senza interruttore/Without handle e without switch
0F01073	Con maniglia/With handle
0F01074	Con interruttore/With switch
0F01075	Con maniglia e interruttore/With handle e switch

FARO LAVORO ALOGENO 156X92MM

PHARE DE TRAVAIL RECTANGULAIRE 156X92MM
 RECTANGULAR HALOGEN WORK LAMP 156X92MM
 RECHTECKIGE HALOGENARBEITSSCHEINWERFER 156X92MM
 FARO DE TRABAJO 156X92MM

Luce ad ampio raggio.
 Supporto orientabile.
 IP55.
 Cablaggio con terminale 6,3
 Ricambi:
 Art.00299 H3 12V 55W (PK22S)
 Art. 00446 H3 24V 70W (PK22S)
 Art. 02590 cavo con spinotto
 Wide beam range,
 twist-and-tilt mounting bracket,
 cable with seal terminated with F/6,3
 IP 55.

Replacement:
 Pn.00299 H3 12V 55W (PK22S)
 Pn. 00446 H3 24V 70W (PK22S)
 PN 02590 Electrical plug and wire



Art./Ref.	Modello/Model	Corpo/Body	Trasparente/Transparent	Note/Note
19146	Con attacco a staffa/Halter	ABS	Vetro/Glass	Lampadina non inclusa. Intercambiabile Hella 1GA998522007 e COBO 05.842.0000 / Bulb not included. Equivalent of Hella 1GA998522007 and COBO 05.842.0000
17689	Con maniglia, interruttore e attacco a staffa (omega)/With handle, switch and omega bracket	ABS	Vetro/Glass	Lampadina non inclusa/Bulb not included
17271	Con attacco a manico/Shank mounting	ABS	Vetro/Glass	Lampadina non inclusa/Bulb not included
19145	Con maniglia, interruttore e con attacco a manico/With handle, switch and shank mounting	ABS	Vetro/Glass	Lampadina non inclusa/Bulb not included
02095	Con maniglia, interruttore, base magnetica e cavo spiralato/With handle,switch,with magnet and coil	ABS	Vetro/Glass	Lampadina Art. 00299 H3 12V 55W (PK22S) inclusa/ Bulb Pn 00299 H3 12V 55W (PK22S) included
17686	Con attacco a staffa (omega)/Omega bracket	ABS	Vetro/Glass	Lampadina non inclusa/Bulb not included

FARO LAVORO ALOGENO 162X111MM BILUCE

PHARE DE TRAVAIL DOUBLE OPTIQUE 162X111MM
 TWIN-BULB HALOGEN WORK LAMP 162X111MM
 DOPPELTER HALOGENARBEITSSCHEINWERFER 162X111MM
 FARO DE TRABAJO 162X111MM DOBLE OPTICA

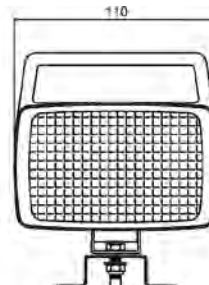
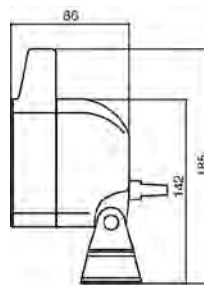

Attacco a staffa (omega), cavo in uscita 0,15m con connettore AMP, IP 65, orientabile,
 Lampadina non inclusa
 Art. 00299 H3 12V 55W (PK22S)
 Art. 00446 H3 24V 70W (PK22S)

Omega bracket, cable 0,15m terminated with AMP Faston, IP 65, twist-and-tilt mounting bracket,
 Bulb not included
 Pn.00299 H3 12V 55W (PK22S)
 Pn. 00446 H3 24V 70W (PK22S)

Art./Ref.	Corpo/Body	Trasparente/Transparent	Flusso luminoso/Luminous flux
17690	ABS	Vetro/Glass	Fascio di luce regolabile (ampio o a lunga portata)/Adjustable light beam (short or long light beam pattern)

KIT 2 FARI DA LAVORO ALOGENI RETTANGOLARI CON GRIGLIA 174X92MM

KIT 2 PHARES DE TRAVAIL 174X92MM LIVRES GRILLE DE PROTECTION
 2 SET HALOGEN WORK LAMPS 174X92MM WITH GRILLE
 2 STK HALOGENARBEITSSCHEINWERFER 174X92MM MIT GITTER
 2 FAROS DE TRABAJO 174X92MM CON REJILLA DE PROTECCION

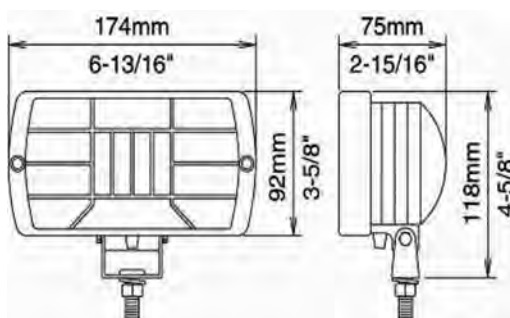

Lampadina art.00299 H3 12V 55 W inclusa
 Cablato
 Confezionamento 2 pz in blister
 Pn 00299 H3 12V 55W bulb included
 Pre-wired
 2 pcs blister packaging

Art./Ref.	Corpo/Body	Trasparente/Transparent	Flusso luminoso/Luminous flux	Brand	Ricambio/Replacement
04741	ABS	Vetro/Glass	Ad ampio raggio/Wide beam range	A.M.A.	02101 - RELE" 12V 20/30 AMP / RELAYS 12V

FARO ALOGENO RETTANGOLARE 195X96MM

PHARE DE TRAVAIL 195X96MM
 HALOGEN WORK LAMP 195X96MM
 RECHTECKIGE HALOGENARBEITSSCHEINWERFER 195X96MM
 FARO DE TRABAJO 195X96MM

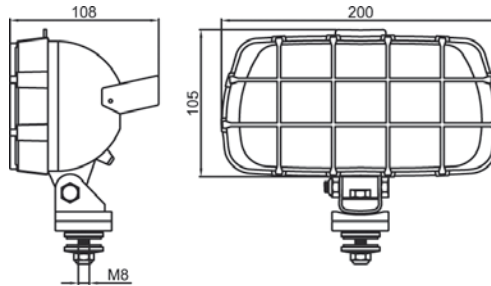

Faro con griglia di protezione, interruttore e maniglia. Staffa orientabile.

Lampadina non inclusa

Art.00299 H3 12V 55W (PK22S)

Art. 00446 H3 24V 70W (PK22S)

Work lamp with grill, switch and handle. Adjustable.

Bulb not included

Pn.00299 H3 12V 55W (PK22S)

Pn. 00446 H3 24V 70W (PK22S)

Art./Ref.	Corpo/Body	Trasparente/Transparent	Flusso luminoso/Luminous flux
01149	ABS	Vetro/Glass	Ad ampio raggio

FARO ALOGENO RETTANGOLARE 156X92MM

PHARE DE TRAVAIL 156X92MM
 HALOGEN WORK LAMP 156X92MM
 RECHTECKIGE HALOGENARBEITSSCHEINWERFER 156X92MM
 FARO DE TRABAJO 156X92MM

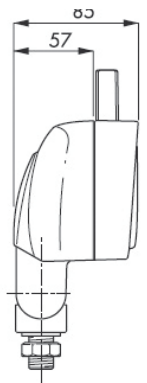
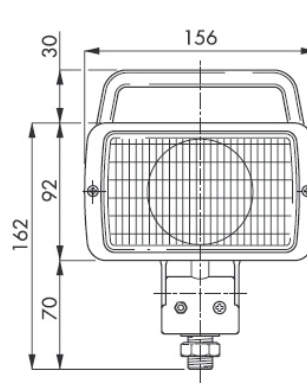

Con interruttore

Orientabile con staffa pivotante

Lampadina non inclusa

art. 00299 H3 12V 55W (PK22S)

art. 00446 H3 24V 70W (PK22S)

With switch

Adjustable with twist and tilt mounting bracket

Bulb not included

Pn 00299 H3 12V 55W (PK22S)

Pn 00446 H3 24V 70W (PK22S)

Art./Ref.	Corpo/Body	Trasparente/Transparent	Flusso luminoso/Luminous flux
03580	Alluminio	Vetro/Glass	Luce ad ampio raggio

FARO LAVORO ALOGENO 169X91 MM CON ATTACCO LATERALE

PHARE DE TRAVAIL 169X91MM LATERAL
 HALOGEN WORK LAMP 169X91MM SIDE CONNECTION
 HALOGENARBEITSSCHEINWERFER 169X91MM MIT SEITLICHER MONTAGE
 FARO DE TRABAJO 169X91MM CON MONTAJE LATERAL

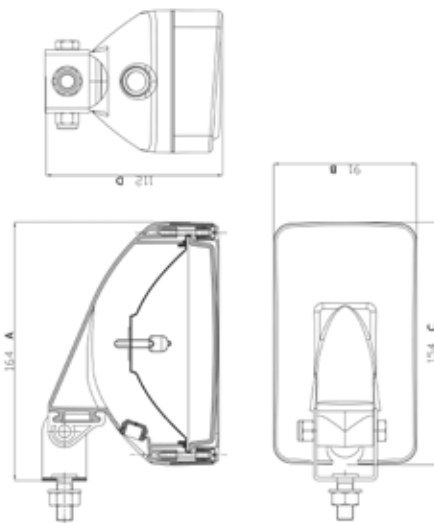

IP45
 Precablato 150 mm,
 Lampadina non inclusa
 Art.00299 H3 12V 55W (PK22S)
 Art. 00446 H3 24V 70W (PK22S)

IP45
 Cable 150mm
 Bulb not included
 Pn.00299 H3 12V 55W (PK22S)
 Pn. 00446 H3 24V 70W (PK22S)

Art./Ref.	Corpo/Body	Trasparente/Transparent	Flusso luminoso/Luminous flux	Modello/Model
0F01081	ABS	Vetro/Glass	Ad ampio raggio/Flood range beam	Manitou, CASE-IH, MF

FARO DA LAVORO ALOGENO Ø 161MM

PHARE DE TRAVAIL Ø 161MM
 HALOGEN WORK LAMPS Ø 161MM
 HALOGENARBEITSSCHEINWERFER Ø 161MM
 FARO DE TRABAJO Ø 161MM

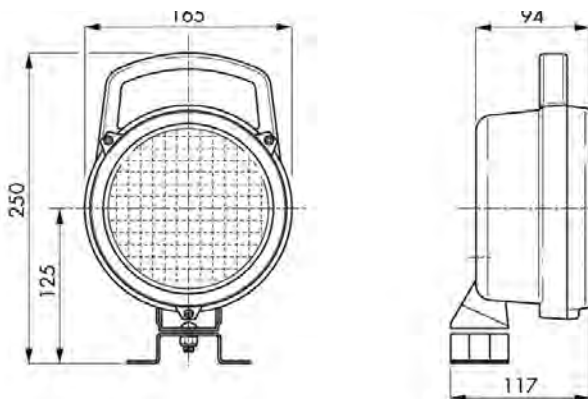

Orientabile
 IP 55
 Ricambi:
 Art. 00299 H3 12V 55W (PK22S)
 Art. 00446 H3 24V 70W (PK22S)
 Art. 02101 Relè 12V 20/30A

Twist and tilt mounting bracket
 IP55
 Replacement:
 Pn.00299 H3 12V 55W (PK22S)
 Pn. 00446 H3 24V 70W (PK22S)
 Pn 02101 Relays 12V 20/30A

Art./Ref.	Modello/Model	Flusso luminoso/Luminous flux	Corpo/Body	Trasparente/Transparent	Note/Note
02084	Con maniglia e interruttore/ With handle and hermetic rocker switch	Ad ampio raggio/Wide beam range	ABS	Vetro/Glass	Lampadina non inclusa/ Bulb not included
02094	Con maniglia, interruttore, base magnetica e cavo spiralato 3,5m/ With handle and hermetic rocker switch	Ad ampio raggio/Wide beam range	ABS	Vetro/Glass	Lampadina art. 00299 H3 12V 55W inclusa /Pn 00299 Bulb H3 12V 55W included

FARO DA LAVORO ALOGENO Ø 135MM

PHARE DE TRAVAIL RONDE Ø 135MM
 HALOGEN WORK LAMP Ø 135MM
 HALOGEN ARBEITSSCHEINWERFER Ø 135MM
 FARO DE TRABAJO Ø 135MM

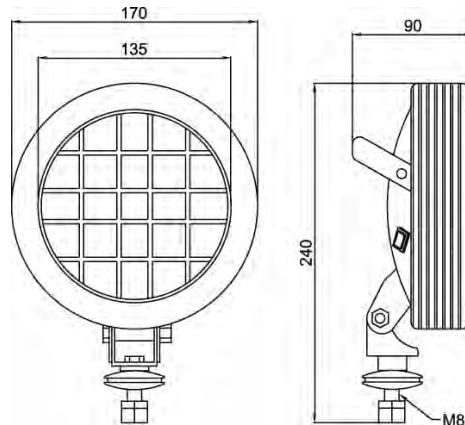

Con interruttore, maniglia e griglia di protezione in plastica
 cavo in uscita
 staffa di fissaggio
 lampadina non inclusa
 art. 00299 H3 12V 55W (PK22S)
 art. 00446 H3 24V 70W (PK22S)

With switch, handle and grill
 Cable
 Twist and tilt mounting bracket Bulb not included
 Pn 00299 H3 12V 55W (PK22S)
 Pn 00446 H3 24V 70W (PK22S)

Art./Ref.	Corpo/Body	Trasparente/Transparent	Flusso luminoso/Luminous flux
02092	Alluminio	Vetro/Glass	Visuale ad ampio raggio

FARI DA LAVORO ALOGENI Ø 118MM

PHARES DE TRAVAIL RONDE Ø 118MM
 HALOGEN WORK LAMPS Ø 118MM
 ARBEITSSCHEINWERFER Ø 118MM
 FAROS DE TRABAJO Ø 118MM

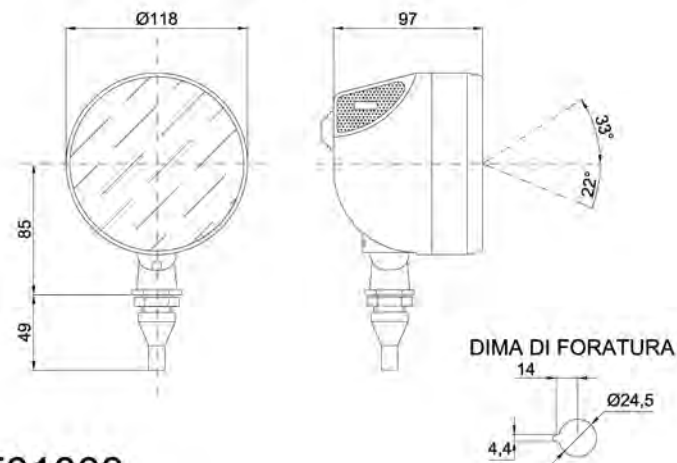

F01003

Orientabili con interruttore
 Cavo in uscita
 Lampadina non inclusa
 art. 00299 H3 12V 55W (PK22S)
 art. 00446 H3 24V 70W (PK22S)
 Twist and tilt mounting bracket With switch
 Cable
 Bulb not include
 Pn 00299 H3 12V 55W (PK22S)
 Pn 00446 H3 24V 70W (PK22S)

Art./Ref.	Modello/Model	Corpo/Body	Trasparente/Transparent	Flusso luminoso/Luminous flux	Brand	Ricambio/Replacement	Rif. Orig./Orig. Ref.
00903	-	ABS	Vetro/Glass	Visuale ad ampio raggio	LANDINI - A.M.A. - SAME - AGRIFULL - MASSEY FERGUSON	01144 - VETRO FANALE / GLASS LIGHT, 02101 - RELE" 12V 20/30 AMP / RELAYS 12 V	73.20.9030.00, 1423870, 1.634.203, 2.8029.300.0
0F01003	Cobo 05.155.000	ABS	Vetro/Glass	Visuale ad ampio raggio	-	-	-

FARO DA LAVORO ALOGENO Ø 110MM IN GOMMA ANTIURTO

MINI-PHARE DE TRAVAIL Ø 110MM CAOUTCHOUC ROND
 HALOGEN WORK LAMP Ø 110MM WITH RUBBER HOUSING
 ARBEITSSCHEINWERFER RUND Ø 110MM GUMMIGEHÄUSE
 FARO DE TRABAJO ALOGENO Ø 110MM EN GOMA ANTICHOQUE

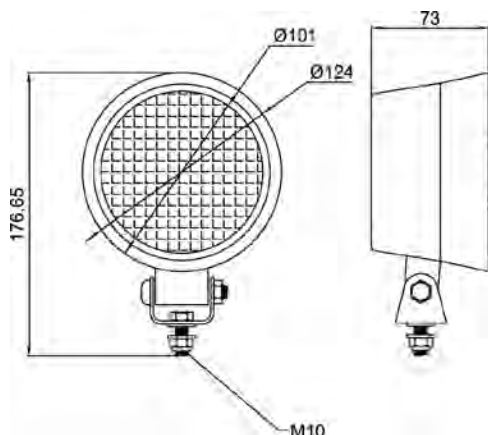

Lampada art. 00299 H3 12V 55W inclusa
 H3 12V 55W bulb included

Art./Ref.	Corpo/Body	Trasparente/Transparent	Flusso luminoso/Luminous flux
02047	Gomma anti-urto	Vetro/Glass	Ad ampio raggio/Wide beam range

FARO LAVORO ALOGENO Ø 80MM

PHARE DE TRAVAIL RONDE Ø 80MM
 HALOGEN WORK LAMP Ø 80MM
 ARBEITSSCHEINWERFER Ø 80MM
 FARO DE TRABAJO Ø 80MM

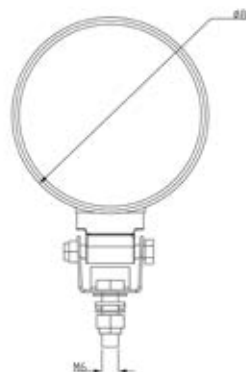
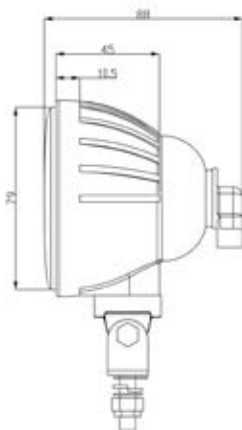

Art. L26065 12V 50W (PGJ13) GE886 inclusa
 Connettore 2 vie Metripack,
 Intercambiabile Cobo 05.0699.000
 Bulb 12V 50W (PGJ13) GE886 included,
 2-Pins connector Metripack,
 Twist and tilt mounting bracket,
 Equivalent of Cobo 05.0699.000

Art./Ref.	Corpo/Body	Trasparente/Transparent	Brand	Ricambio/Replacement	Accessorio/null
0F01079	ABS	Vetro/Glass	A.M.A.	L26065 - LAMP:GE886 12V PGJ13 50W CONN. / LAMP:GE886 12V PGJ13 50W CONN.	AM001

FARO LAVORO Ø 84MM

MINI-PHARE DE TRAVAIL ROND A REFLECTEUR Ø 84MM
 WORK LAMP Ø 84MM
 ARBEITSSCHEINWERFER Ø 84MM
 FARO LAVORO ROTONDO Ø 84MM

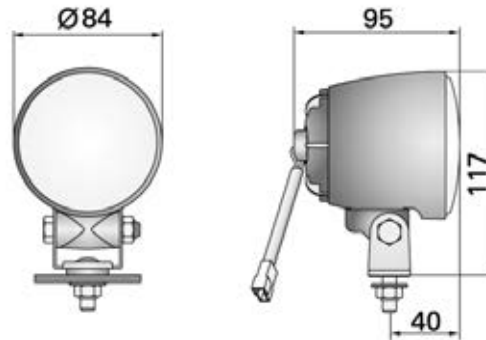

IP68
 Cablaggio 200mm con connettore AMP
 Lampadina non inclusa
 Art. 00299 H3 12V 55W (PK22S)
 Art. 00446 H3 24V 70W (PK22S)
 Intercambiabili Hella 1G0996176001/1G0996176111

IP68
 Cable 200 mm with AMP connector
 Bulb not included
 Pn 00299 H3 12V 55W (PK22S)
 Pn 00446 H3 24V 70W (PK22S)
 Equivalent of Hella 1G0 996 176-001 and 1G0 996 176-111 part number

Art./Ref.	Corpo/Body	Trasparente/Transparent	Flusso luminoso/Luminous flux
76478	ABS	Vetro/Glass	Ad ampio raggio/Wide beam range

FARI DA LAVORO ALOGENI OVALI

PHARE DE TRAVAIL OVALE
 HALOGEN OVAL WORK LAMPS
 HALOGENARBEITSSCHEINWERFER-OVAL
 FARO DE TRABAJO ALOGENO OVALO

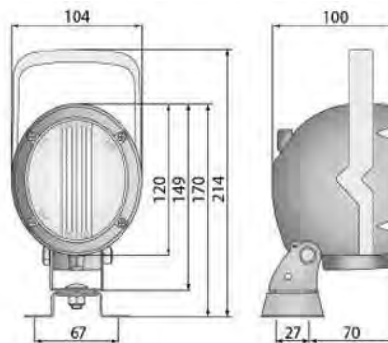

Staffa orientabile
 IP 65
 Connettore AMP 2 pin
 Lampadina non inclusa
 art. 00299 H3 12V 55W (PK22S)
 art. 00446 H3 24V 70W (PK22S)
 Intercambiabile con Hella 1GM996134241 e 1GM996134171

Twist and tilt mounting bracket
 IP 65
 Waterproof AMP faston 2-pin cap connector
 Bulb not included
 Pn 00299 H3 12V 55W (PK22S)
 Pn 00446 H3 24V 70W (PK22S)
 Equivalent of Hella 1GM996134241, 1GM996134171 part number

Art./Ref.	Modello/Model	Flusso luminoso/Luminous flux	Corpo/Body	Trasparente/Transparent
76134	Con maniglia/With handle	Raggio a lunga portata/Long range beam	ABS	Vetro/Glass
76474	Senza maniglia/Without handle	Raggio a lunga portata/Long range beam	ABS	Vetro/Glass

FARI DA LAVORO PRISMATI

PHARES DE TRAVAIL OVAL ECLAIRAGE LARGE
 OVAL WORK LAMPS
 ARBEITSSCHEINWERFER OVAL
 FAROS DE TRABAJO OVAL

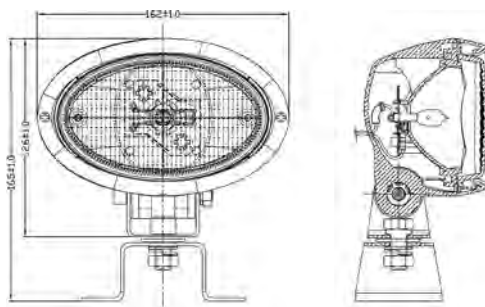

Connettore AMP
 Resistenza agli urti PA6
 IP65
 Lampadina art. 00299 H3 12V 55W (PK22S) inclusa
 External AMP connection
 Impact resistant PA6 housing
 IP65
 Bulb pn 00299 H3 12V 55W (PK22S) included

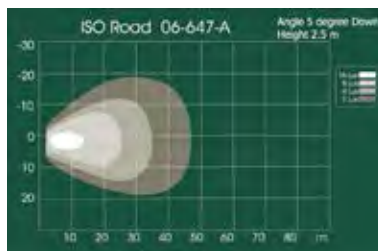

Art./Ref.	Modello/Model	Corpo/Body	Trasparente/Transparent	Flusso luminoso/Luminous flux
84378	Singolo fascio di luce/Single flood beam	ABS	Vetro/Glass	Ad ampio raggio
84379	Doppio fascio di luce/Double flood beam	ABS	Vetro/Glass	Ad ampio raggio

FARI DA LAVORO OVALI

PHARE DE TRAVAIL OVAL AVEC ECLAIRAGE LARGE
 WORK LAMP LONG RANGE BEAM
 ARBEITSSCHEINWERFER OVAL
 FARO DE TRABAJO OVAL CON VISION DE LARGO ALCANCE

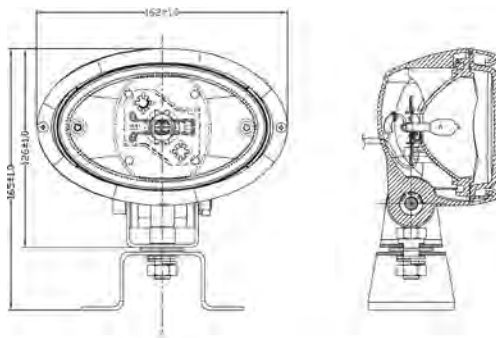

Connettore AMP
 Resistenza agli urti PA6
 IP65
 Lampadina art. 00299 H3 12V 55W (PK22S) inclusa
 External AMP connection
 Impact resistant PA6 housing
 IP65
 Bulb pn 00299 H3 12V 55W (PK22S) included

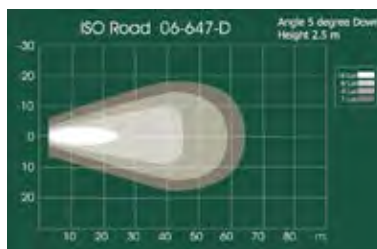

Art./Ref.	Modello/Model	Corpo/Body	Trasparente/Transparent	Flusso luminoso/Luminous flux
84380	Singolo fascio di luce/Single flood beam	ABS	Vetro/Glass	/Raggio a lunga portata
84381	Doppio fascio di luce/Double flood beam	ABS	Vetro/Glass	Raggio a lunga portata

1.8.9 Fanali Anteriori

Work light



Ricambi & accessori per macchine agricole

SPARE PARTS & ACCESSORIES FOR AGRICULTURAL MACHINE

Tutti gli articoli della presente sezione, prodotti da AMA SPA e/o da terzi per conto di AMA, sono adattabili ("non originali") alle marche indicate ai sensi di quanto previsto dal REG. CE n. 1400/2002. I diritti sui marchi citati appartengono ai legittimi proprietari ed il loro uso ha l'esclusiva finalità di consentire all'utilizzatore la comparazione dei diversi prodotti. All items of this section, manufactured by AMA SPA and/or any third party on behalf of AMA, are adaptable ("non-original") to the brands listed under the provisions of the REG. CE n. 1400/2002. The rights on the trademarks belong to their respective owners and their usage is only aimed to allow the user to compare different products.

PROIETTORI 265X120MM CON INDICATORE DI DIREZIONE

PHARES DE ROUTE 265X120MM
 HEADLAMPS 265X120MM WITH INDICATOR LIGHT
 SCHEINWERFER 265X120MM MIT BLINKER
 FAROS DELANTERO 265X120MM CON INTERMITENCIA

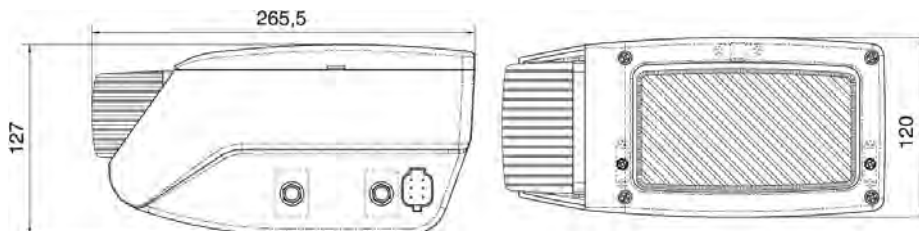

Note: Lampadine 12V incluse
 art. 00451 12V 3W (BA9S) T4W per luce di posizione
 art. 00373 H4 12V 55/60W (P43T) per abbagliante/anabbagliante
 art. 00441 12V 21W (BA15S) per indicatore di direzione
 art. 12491 blocchetto 3 vie per lampada asimmetrica
 Kit connettore: art. 37889

Notes: Bulbs 12V included:
 Pn 00451 12V 3W (BA9S) T4W for position light
 Pn 00373 H4 12V 55/60W (P43T) for high and low beam
 Pn 00441 12V 21W (BA15S) for indicator light
 Pn 12491 3 way connection house for asymmetric bulb
 Connector: pn 37889

Art./Ref.	Lato/Side	Luci/Lights	Modello/Model
12955	Dx	Abbagliante e anabbagliante, posizione e indicatore di direzione/ High and low beam, position and direction light	Merlo, JCB, Genie Terex, Manitou, Ausa, Eurocomach
12956	Sx	Abbagliante e anabbagliante, posizione e indicatore di direzione/ High and low beam, position and direction light	Merlo, JCB, Genie Terex, Manitou, Ausa, Eurocomach

PROIETTORI 235X143MM CON INDICATORI DI DIREZIONE

PHARES DE ROUTE 235X143MM
 HEADLAMPS 235X143MM WITH INDICATOR LIGHT
 SCHEINWERFER 235X143MM MIT BLINKER
 FAROS DELANTERO 235X143MM CON INTERMITENCIA

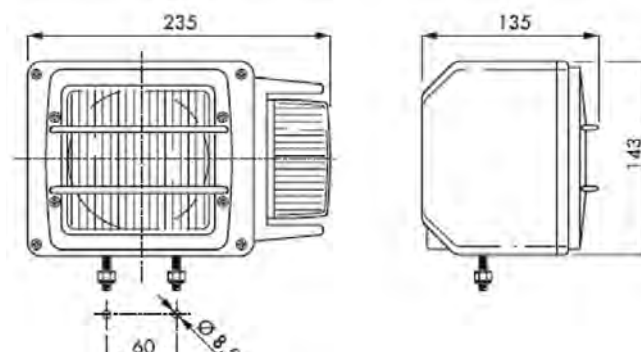

Note: Interasse di fissaggio 60 mm con fori 8.5 mm
 Ricambio connettore gruppo fanale:
 Art. 12491 1 pz blocchetto 3 vie per lampada asimmetrica
 Art. 02582 3 pz faston femmina con ling. 1-2,5
 Kit connettore:
 Art. 12589 1 pz blocchetto connessione 6 vie maschio
 Art. F22039 6 pz faston femmina con gancio 6,3
 Lampadine 12V incluse:
 art. 00451 12V 3W (BA9S) T4W per luce di posizione
 art. 00295 12V 40/45W (P45T)R2 per abbagliante e anabbagliante
 art. 00441 12V 21W (BA15S) per indicatore di direzione
 Omologazione CE

Notes:
 Kit for asymmetric bulb:
 Pn 124911 pcs : 3way connection for asymmetric bulb
 Pn 02582 3 pcs: clip
 Kit for connection:
 Pn 12589 1 pcs: 6way male connection
 Pn F22039 6 pcs: clip
 Bulbs 12V included:
 Pn 00451 12V 3W (BA9S) T4W for position light
 Pn 00295 12V 40/45W (P45T)R2 for high and low beam
 Pn 00441 12V 21W (BA15S) for indicator light
 CE Approval

Art./Ref.	Lato/Side	Luci/Lights
04219	Dx	Abbagliante e anabbagliante, posizione e indicatore di direzione/ High and low beam, position e direction light
05607	Sx	Abbagliante, anabbagliante e luce di direzione

PROIETTORE 150X212MMMM VERTICALE CON INDICATORE DI DIREZIONE

PHARES DE ROUTE 150X212MM AVEC INDICATEUR DE DIRECTION
 HEADLIGHT 150X212MM WITH INDICATOR LIGHT
 SCHEINWERFER 150X212MM MIT BLINKER
 FAROS DELANTERO 150X212MM CON INTERMITENCIA

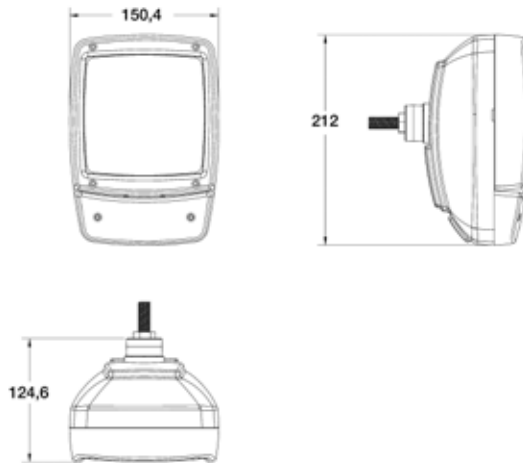

Note: Lampadine non incluse.
 art. 34536: 12V H7 (PX26D) per abbagliante e anabbagliante
 art. 00451: 12V 3W (BA9S) T4W per luce posizione
 art. 00299: 12V 3W (BA9S) T4W
 per fendinebbia
 art. 00441: 12V 21W (BA15S)
 per luce di direzione

Notes: Bulbs not include.
 Pn. 34536: 12V H7 (PX26D) for high and low beam
 Pn. 00451: 12V 3W (BA9S) T4W for position light
 Pn. 00299: 12V 3W (BA9S) T4W
 for foggy light
 Pn. 00441: 12V 21W (BA15S)
 for direction light

Art./Ref.	Lato/Side	Luci/Lights	Modello/Model
69318	Dx/Sx	Abbagliante, anabbagliate, fendinebbia, luce di posizione e luce di direzione/ High and low beam, foggy light, position and direction light	JCB, Volvo, CAT

PROIETTORE 155X212MMMM VERTICALE CON INDICATORE DI DIREZIONE

PHARES DE ROUTE 155X212MM AVEC INDICATEUR DE DIRECTION
 HEADLIGHT 155X212MM WITH INDICATOR LIGHT
 SCHEINWERFER 155X212MM MIT BLINKER
 FAROS DELANTERO 155X212MM CON INTERMITENCIA

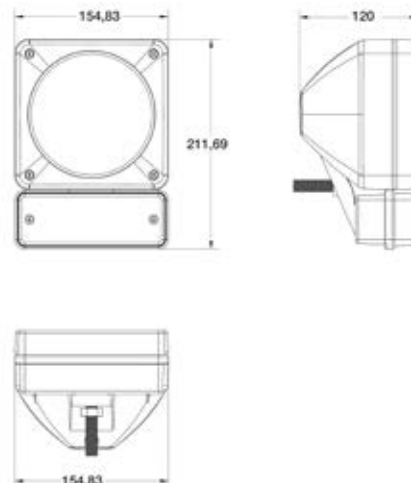

Note: Lampadine non incluse.
 art. 00295 12V 40/45W (P45T)R2
 per abbagliante e anabbagliante
 art. 00441 12V 21W (BA15S)
 per indicatore di direzione

Notes: Bulbs not included.
 Pn. 00295 12V 40/45W (P45T)R2
 for high and low beam
 Pn. 00441 12V 21W (BA15S)
 for direction light

Art./Ref.	Lato/Side	Luci/Lights	Modello/Model
69345	Dx/Sx	Abbagliante, anabbagliante e luce di direzione	JCB, Volvo, CAT

PROIETTORI SIMMETRICI 140X140MM

PHARES DE ROUTE 140X140MM

SYMMETRIC HEADLAMPS 140X140MM

EINBAUSCHEINWERFER 140X140MM

FAROS DELANTERO 140X140MM

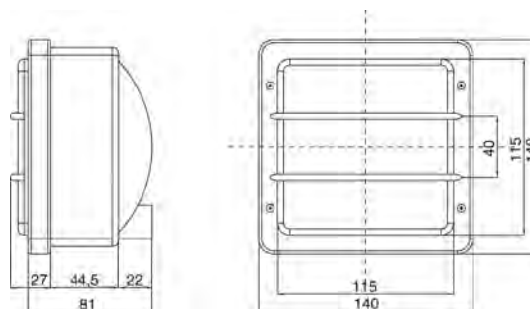
Note: Omologazione: E3 M 33199-33200
 Adattabile MF Landini, Lindner, Same, Deutz-Fahr

Notes: E3 M 33199-33200 Approved
 MF Landini, Lindner, Same, Deutz-Fahr

Art./Ref.	Lato/Side	Luci/Lights	Fissaggio/Fissaggio	Collegamento/Connection	Colore/Color	Modello/Model	Note/Note
01621	Dx/Sx	Luce di posizione, abbagliante e anabbagliante/ Position light, low and high beam	Viti	Pres a bassa	Corpo arancione e cornice cromata/ Orange housing and chromium plated bezel	COBO 05.102.000	art. 00439 12V 45/40W (BA20D) o art.00391 24V 50/45W (BA20D) per luce abbagliante e anabbagliante, art. 00451 12V 3W (BA9S) T4W o art.00525 24V 3W (BA9S) T4W per luce di posizione/ Pn 00439 12V 45/40W (BA20D) or Pn.00391 24V 50/45W (BA20D) for high and low beam, PN 00451 12V 3W (BA9S) T4W or Pn.00525 24V 3W (BA9S) T4W for position light
01468	Dx/Sx	Abbagliante e anabbagliante/ High and low beam	Molla	Pres a bassa	Corpo nero cornice nera/Black housing and bezel	COBO 05.132.000	art. 00439 12V 45/40W (BA20D) o art.00391 24V 50/45W (BA20D) per luce abbagliante e anabbagliante/ Pn 00439 12V 45/40W (BA20D) or Pn.00391 24V 50/45W (BA20D) for high and low beam
01469	Dx/Sx	Abbagliante e anabbagliante/ High and low beam	Molla	Pres a bassa	Corpo arancione e cornice nera/ Orange housing and black bezel	COBO 05.103.000	art. 00439 12V 45/40W (BA20D) o art.00391 24V 50/45W (BA20D) per luce abbagliante e anabbagliante/ Pn 00439 12V 45/40W (BA20D) or Pn.00391 24V 50/45W (BA20D) for high and low beam
01470	Dx/Sx	Luce di posizione, abbagliante e anabbagliante/ Position light, High and low beam	Molla	Pres a alta	Corpo nero e cornice nera/Black housing and bezel	COBO 05.160.000	art. 00295 12V 45/40W (BA20D) per luce abbagliante e anabbagliante, art. 00451 12V 3W (BA9S) T4W o art.00525 24V 3W (BA9S) T4W per luce di posizione/ Pn 00295 12V 45/40W (BA20D) per luce abbagliante e anabbagliante, Pn. 00451 12V 3W (BA9S) T4W or Pn.00525 24V 3W (BA9S) T4W for position light

RICAMBI

RECHANGES

SPARE PARTS

ERSATZTEILE

RECAMBIOS

Note: Modelli Cobo **Notes:** Cobo

Art./Ref.	Tipo/Type	Applicazione/Application
00792	Lente/Len	01468, 01469, 01470, 01621
00791	Cornice nera /Black frame	01468, 01469, 01470
00833	Cornice cromata /Chromed frame	01621

PROIETTORE ASIMMETRICO 152X152MM

PHARE DE ROUTE 152X152MM
 ASYMMETRIC HEADLAMPS 152X152MM
 HAUPTSCHWEINWERFER MIT HALTERUNG 152X152MM
 FARO DELANTERO 152X152MM

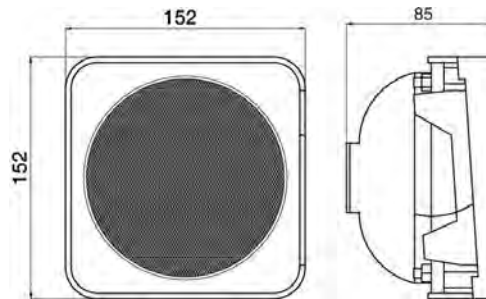

Note: Lampadina non inclusa
 art. 00295 Lampadina 12V 40/45W (P45T)R2

Notes: Bulb not included
 Pn 00295 12V 40/45W (P45T)R2

Art./Ref.	Luci/Lights	Lato/Side	Modello/Model
02811	Abbagliante e anabbagliante/High and low beam	Dx/Sx	Trattore FIAT: 570-670-580-680880-980-1180-1280-1380-1580-1880-855 CING - 955 CING. e AGRIFULL

PROIETTORE ASIMMETRICO 3 ATTACCHI 193X170MM

PHARE DE ROUTE 193X170MM
 ASYMMETRIC HEADLAMPS WITH 3 BASES 193X170MM
 SCHEINWERFEREINSATZ 193X170MM
 FARO DELANTERO 193X170MM

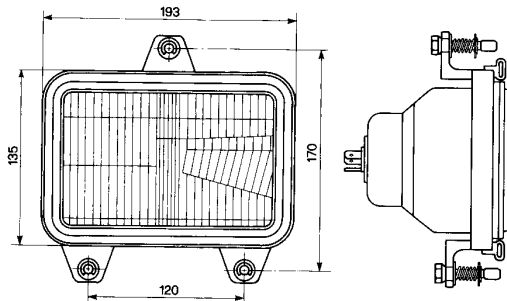

Note: Lampadina: art. 00295 12V 40/45W (P45T) R2
 Materiale riflettore: plastica
 Cuffia di protezione: gomma
 Particolari metallici: resistenti alla nebbia salina norma UNI5687-73
 Omologazione: ECE

Notes: Bulb: pn 00295 12V 40/45W (P45T) R2
 Protection cup: rubber
 Metallic parts: UNI5687-73
 ECE approval

Art./Ref.	Luci/Lights	Lato/Side	Modello/Model	Brand	Applicazione/Application	Rif. Orig./Orig. Ref.
26946	Abbaglianti e anabbaglianti/ High and low beam	Dx/Sx	COBO 05.309.000	FIAT	65-94DT, 65.94, 72-94DT, 72.94, 82-94DT, 82.94, 88-94DT, 88.94, F 100, F 100DT, F 110, F 110DT, F 115, F 115DT, F 120, F 120DT, F 130, F 130DT, F 140, F 140DT	5154453

PROIETTORE 191X135MM

PHARE DE ROUTE 191X135MM

HEADLAMP 191X135MM

HAUPTSCHWEINWERFER MIT HALTERUNG 191X135MM

FARO DELANTERO 191X135MM



Note: Lente in vetro
Lampadine non incluse.
art. 00295 12V 40/45W (P45T)R2
per abbagliante e anabbagliante

Notes: Glass Lens
Bulb not included
Pn 00295 12V 40/45W (P45T)R2
for high and low beam

Art./Ref.	Luci/Lights	Lato/Side	Modello/Model
02860	Abbagliante e anabbagliante/High and low beam	Dx /Sx	FIAT 55-46, FIAT AGRIS 56bis 9959903, CASE-IH 5138350

PROIETTORI ASIMMETRICI 120X110MM A 3 ATTACCHI

PHARES DE ROUTE 120X110MM

ASYMMETRIC HEADLAMPS 120X110MM WITH 3 BASES

SCHEINWERFEREINSATZ 120X110MM

FAROS DELANTERO 120X110MM

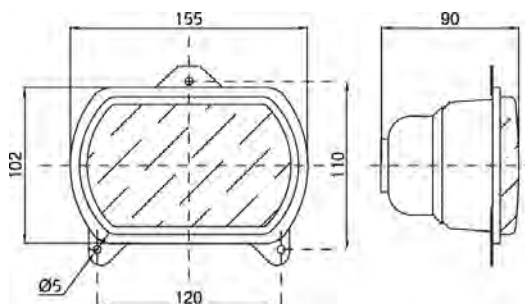

Note: Lampadine non incluse
Lampadina per luce abbagliante e anabbagliante: art. 00295 12V 40/45W (P45T) R2
Lampadina per luce di posizione: art. 00451 12V 3W (BA9S) T4W
Cuffia di protezione: gomma
Particolari metallici: resistenti alla nebbia salina norma UNI5687-73
Omologazione ECE

Notes: Bulb not included
Bulb for high and low beam: pn 00295 12V 40/45W (P45T) R2
Bulb for position light: pn 00451 12V 3W (BA9S) T4W
Protection cup: rubber
Metallic parts: UNI5687-73
ECE approval

Art./Ref.	Lato/Side	Luci/Lights	Modello/Model	Brand	Applicazione/Application	Rif. Orig./Orig. Ref.
01364	Dx/Sx	Abbaglianti e anabbaglianti/ High and low beam	COBO 05.389.000	SAME LAMBOR- GHINI HURLI- MANN - FIAT - NEW HOLLAND - FORD	45-66, 45-66 DT, 45-66S, 45-66S DT, 45-76 V, 50-66, 50-66 DT, 50-66S, 50-66S DT, 55-66 DT LP, 55-66 F, 55-66 LP, 55-66 V, 55-66 V DT, 55-76 F, 55-76 F DT, 55-76 V, 55-76 V DT, 56-66S, 56-66S DT, 60-66 F, 60-66 F DT, 60-66 LP, 60-66 LP DT, 60-76 F, 60-76 F DT, 70-66 F, 70-66 F DT, 70-66 LP, 70-66 LP DT, 70-66 V, 70-76 F, 70-76 F DT, 70-76 LP, 70-76 LP DT, 72-86 F, 72-86 F DT, 80-66 F, 80-66 F DT, 80-76 F, 80-76 F DT, 82-86 F, 82-86 F DT, 3435, 3935, 4135, 4230, 4430, 60-65 V, TK55-65 F, TK55-65 M, TK55-65 V, TK55-75 M, TK55-75 V, TK55-85 F, TK55-85 M, TK55-85 V, TK60-75, TK60-75 M, TK60-75 V, TK60-85 F, TK60-85 V, ANTARES, ARGON, ASTER 60 - 70, EXPLORER II, EXPLORER II SPECIAL, EXPLORER SPECIAL, FRUTTETO II, ROW CROP	5126153, 5177846, 5126153, 5177846, 5126153, 5177846, 2.8029.900.0/10
03988	Dx/Sx	Abbaglianti, ana- bbaglianti e luce di posizione/High and low beam, position light	COBO 05.411.000	-	-	-

PROIETTORI RETTANGOLARI

PHARES DE ROUTE RACNGULAIRES
 RECTANGULAR HEADLAMP
 RECHTECKIGE SCHEINWERFER
 FAROS DELANTERO RECTANGULAR

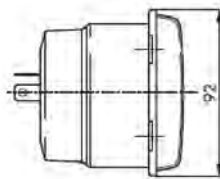
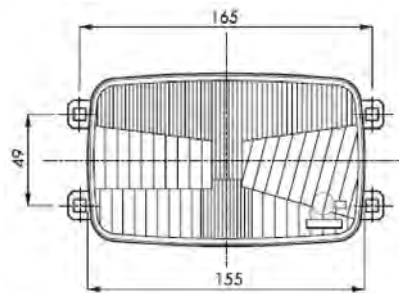
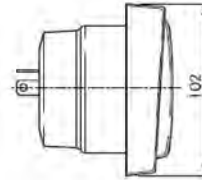
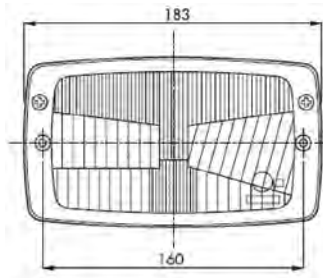

Note: Lente in vetro

Lampadine non incluse Lampadina per abbagliante e anabbagliante:
 art. 00373 H4 12V 55/60W (P43T); art. 0375 H4 24V 70/75W (P43T)
 Lampadine per luce di posizione:
 art. 00451 12V 3W (BA9S) T4W; art. 00525 24V 3W (BA9S) T4W
 Omologazione: E8

Notes: Glass lens Bulb not included

Bulb for high and low beam:
 pn 00373 H4 12V 55/60W (P43T); pn 0375 H4 24V 70/75W (P43T)
 Bulb for parking light:
 pn 00451 12V 3W (BA9S) T4W; pn 00525 24V 3W (BA9S) T4W
 E8 approval

Art./Ref.	Lato/Side	Luci/Lights	Specifiche/Specifications	Modello/Model	Tipo/Type
09860	Dx/Sx	Luci Abbaglianti anabbaglianti e di posizione/ High and low beam, position light	184x102mm	Zetor, Zetor Forterra, Zetor Proxima, Fendt, Fendt Farmer, Fendt Favorit, Ursus, Pronar, John Derre, Farmer, Farmatrac, Ammann, Bomag, Div, Doosan, Hamm, Hyundai	Intercambiabile con Hella 1AB 006 213-011 e COBO 05.522.000/Intercambiabile con Hella 1AB 006 213-011 e COBO 05.522.000/Replacement with Hella 1AB 006 213-011 and COBO 05.522.000/Intercambiabile con Hella 1AB 006 213-011 e COBO 05.522.000/Intercambiabile con Hella 1AB 006 213-011 e COBO 05.522.000
17270	Dx/Sx	Abbagliante anabbagliante e luce di posizione/ High and low beam, position light	165x93mm	-	Intercambiabile con COBO 05.508.000/Intercambiabile con COBO 05.508.000/Replacement with COBO 05.508.000/Intercambiabile con COBO 05.508.000/Intercambiabile con COBO 05.508.000

PROIETTORE 184X102MM FISSAGGIO CON SNODO
PHARE DE ROUTE 184X102MM FIXATION AVEC ARTICULATION
HEADLAMP 184X102MM FIXED ON THE SHAFT
SCHEINWERFER IM GEHAUSE 184X102MM AUF DEM STIEL MONTIERT
FARO DELANTERO 184X102MM FIJACIÓN CON CONJUNTO

Note: Lampadine non incluse

Lampadina per abbagliante e anabbagliante:

art. 00373 H4 12V 55/60W (P43T); art. 0375 H4 24V 70/75W (P43T)

Lampadine per luce di posizione:

art. 00451 12V 3W (BA9S) T4W; art. 00525 24V 3W (BA9S) T4W

Corpo in plastica

Lente in vetro

Omologazione E8

Intercambiabile:

COBO 05.526.000

HELLA 1AB007145007

Notes: Bulb not included

Bulb for high and low beam:

pn 00373 H4 12V 55/60W (P43T); pn 0375 H4 24V 70/75W (P43T)

Bulb for position light:

pn 00451 12V 3W (BA9S) T4W; pn 00525 24V 3W (BA9S) T4W

Plastic housing

Glass len

E8 approval

Replacement:

COBO 05.526.000

HELLA 1AB007145007

Art./Ref.	Luci/Lights	Lato/Side	Modello/Model
27238	Abbagliante, anabbagliante e luce di posizione/High and low beam, position light	Dx/Sx	Zetor Proxima, Zetor Forterra

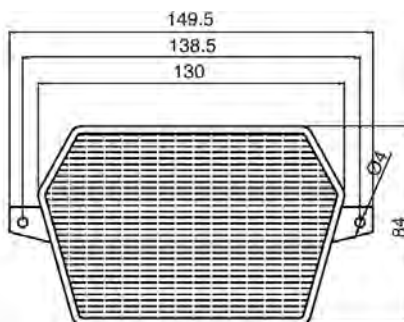
PROIETTORE 138,5X84MM CON DUE ATTACCHI
PHARE DE ROUTE 138,5X84MM
HEADLAMPS WITH 2 BASES 138,5X84MM
SCHEINWERFEREINSATZ 138,5X84MM
FARO DELANTERO 138,5X84MM

Note: Lampadine non incluse

Art.00451 12V 3W (BA9S) T4W

per luce di posizione

Art.00439 12V 45/40W (BA20D) per luce abbagliante a anabbagliante

Notes: Bulbs not included

Pn.00451 12V 3W (BA9S) T4W

for position light

Pn.00439 12V 45/40W (BA20D) for high and low beam

Art./Ref.	Lato/Side	Luci/Lights	Modello/Model
01418	Dx/Sx	Luce di posizione, luce abbagliante anabbagliante/Position light, high and low beam	PASQUALI

PROIETTORE Ø 153MM

PHARE DE ROUTE Ø 153MM
 HEADLAMP Ø 153MM
 SCHEINWERFER RUND Ø 153MM
 FARO DELANTERO Ø 153MM

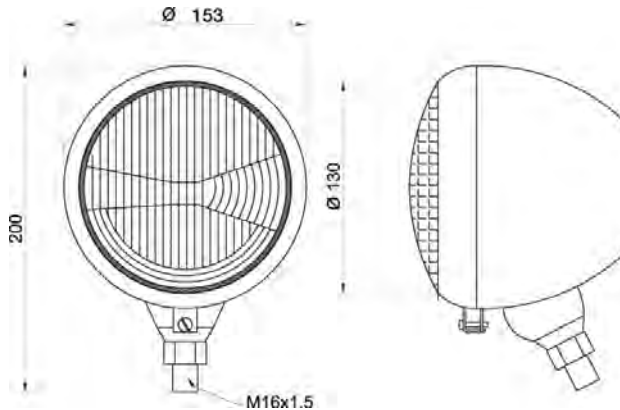

Note: Attacco M16,
 Corpo in alluminio,
 Lente in vetro
 Lampadine non incluse
 Art. 00295 12V 40/45W (P45T)R2 per Abbaglianti e anabbaglianti
 Art. 00451 12V 3W (BA9S) T4W per luce di posizione

Notes: Screw M16
 Aluminum housing
 Glass Lens
 Bulbs not included
 Pn 00295 12V 40/45W (P45T)R2 For High and low beam
 Pn 00451 12V 3W (BA9S) T4W for position light

Art./Ref.	Luci/Lights	Lato/Side
02850	Abbagliante, anabbagliante e luce di posizione/High and low beam, position light	Dx/Sx

PROIETTORE Ø 161MM

PHARE DE ROUTE Ø 161MM
 HEADLAMP Ø 161MM
 SCHEINWERFER Ø 161MM
 FARO DELANTERO Ø 161MM

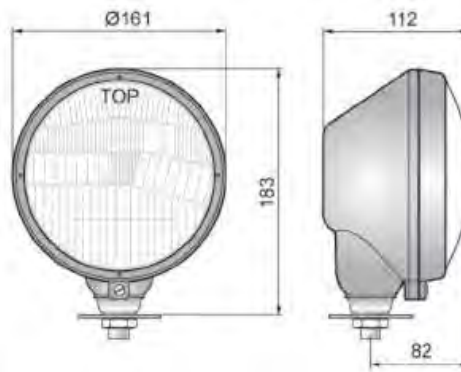

Note: Corpo in plastica e lente in vetro, Lampadine art. 00295 12V 40/45W (P45T)R2 e art. 00451 12V 3W (BA9S) T4W incluse
 Possibilità di montare anche lampadine a 24V
 Omologazione E20

Notes: PC housing Glass len
 Bulb pn 00295 12V 40/45W (P45T)R2 & pn 00451 12V 3W (BA)S T4W included
 E20 approval

Art./Ref.	Lato/Side	Luci/Lights	Modello/Model
02849	Dx/Sx	Abbagliante, anabbagliante, luce di posizione/High and low beam, position light	Zetor: 2011, 3011, 3511,4011,6711

PROIETTORE Ø 154MM BLU

PAHRE DE ROUTE BLUE Ø 154MM
 BLUE HEADLAMP Ø 154MM
 SCHEINWERFER RUND Ø 154MM BLUE
 FARO DELANTERO AZUL Ø 154MM

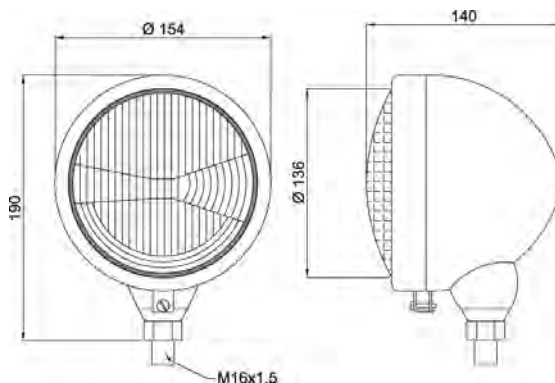

Note: Adattabile a trattore Ford 82003398
 Corpo in alluminio e lente in vetro
 Lampadine non incluse
 Art. 00295 12V 40/45W (P45T)
 per luce abbagliante a anabbagliante
 Art. 00398 12V 3W (T10)
 per luce di posizione
 Art. S14064 portalamпада per luce di posizione

Notes: Adaptable to Ford 82003398, Aluminum housing and glass lens
 Bulbs not included
 Art. 00295 12V 40/45W (P45T)
 for high and low beam
 Art. 00398 12V 3W (T10)
 for position light
 Art. S14064 lamp holder for position light

Art./Ref.	Lato/Side	Colore/Color	Luci/Lights
02859	Dx/Sx	Blu/Blue	Luce di posizione , luce abbagliante e anabbaliante/Position light, low and high beam

FANALE ANTERIORE A 2 LUCI PER TRATTORI FIAT-OM

PHARE AVANT 2 FEUX POUR TRACTEURS FIAT-OM
 HEAD LAMPS FOR FIAT-OM TRACTORS
 VORDERLEUCHTE 2-LEUCHTEN FÜR FIAT-OM TRAKTOREN
 FAROL ANTERIOR CON 2 LUCES PARA TRACTORES FIAT-OM



Note: Lampadine non incluse
 Art. 00439 12V 45/40W (BA20D)
 Art. 00451 12V 3W (BA9S) T4W
 Art. 02810 gruppo ottico

Notes: Bulb not included
 Pn 00295 12V 40/45W (P45T)
 Pn 00451 12V 3W (BA9S) T4W
 Pn 02810 optical unit

Art./Ref.	Lato/Side	Colore/Color	Luci/Lights	Brand	Applicazione/ Application	Rif. Orig./ Orig. Ref.
02805	Dx	Arancio/Orange	Abbagliante, anabbagliante, luce di posizione/ High and low beam, position light	FIAT	1000, 1300, 300, 350, 355, 450, 455, 480, 500, 505, 540, 605, 640, 650, 655, 750, 805, 850	4178214, 5118923, 5118925, 5118926, 5118927, 5118928
02806	Sx	Arancio/Orange	Abbagliante, anabbagliante, luce di pozione/ High and low beam, position light	FIAT	1000, 1300, 300, 350, 355, 450, 455, 480, 500, 505, 540, 605, 640, 650, 655, 750, 805, 850	5118924, 5118925, 5118926, 5118927, 5118928

SUPPORTO PER FANALI FIAT ART. 02805 - 02806

SUPPORT POUR PHARES FIAT ART. 02805 - 02806
 SUPPORT FOR FIAT HEAD LAMPS ART. 02805 - 02806
 TRÄGER FÜR FIAT-VORDERLEUCHTEN ART. 02805 - 02806
 SOPORTE PARA FAROLES FIAT ART. 02805 - 02806



Art./Ref.	Brand	Applicazione/Application	Rif. Orig./Orig. Ref.
03017	FIAT - A.M.A.	02805, 02806	4951145

FANALE DIREZIONE- POSIZIONE 114X76MM

FEU AVANT 114X76MM
 FRONT LAMP 114X76MM
 BLINK-POSITIONSLEUCHTE 114X76MM
 PILOTO DELANTERO 114X76MM

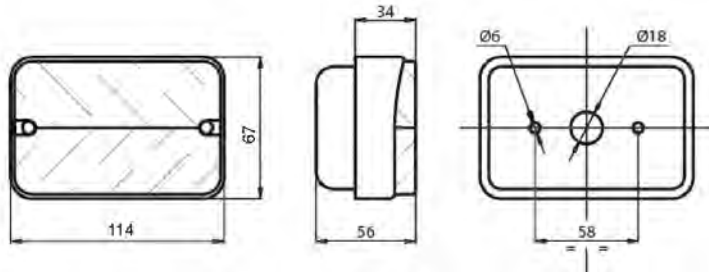

Note: Lampadine non incluse
 Lampadina per luce di direzione: 00441 12V 21W (BA15S)
 Lampadina per luce di posizione: 00397 12V 5W (BA15S)
 Interasse di fissaggio 60mm
 Fori Ø 6 mm

Notes: Bulb not included
 Bulb direction: 00441 12V 21W (BA15S)
 Bulb position light: 00397 12V 5W (BA15S)
 Distance between holes 60mm,
 Holes Ø 6mm

Art./Ref.	Lato/Side	Luci/Lights
00464	Dx/Sx	Direzione e luce di posizione/Direction and position light

FANALI DIREZIONE-POSIZIONE 120X80MM CON ATTACCO LATERALE

FEU AVANT 120X80MM
 FRONT LAMP 120X80MM WITH LATERAL CONNECTION
 BLINK-POSITIONSLEUCHTE 120X80MM
 PILOTO DELANTERO 120X80MM

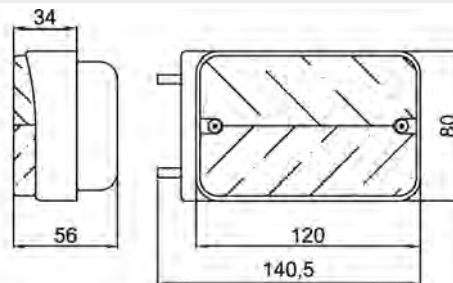

Note: Protezione IP55
 Lampadina per luce di direzione: 00441 12V 21W (BA15S)
 Lampadina per luce di posizione: 00397 12V 5W (BA15S)
 Omologazione CE
 Adatto a: CNH 1-34-173-070 - NEW HOLLAND 320461700 - ARGO GROUP 4202738M92 -
 CNH 303597A1 - CNH 5136373 - LANDINI 4202738M92
 Deutz-Fahr 2.8019.960.0/02

Notes: Waterproof rate: IP55
 Bulb direction: 00441 12V 21W (BA15S)
 Bulb position light: 00397 12V 5W (BA15S)
 CE approved
 Suitable: CNH 1-34-173-070 - NEW HOLLAND 320461700 - ARGO GROUP
 4202738M92 - CNH 303597A1 - CNH 5136373 - LANDINI 4202738M92
 Deutz-Fahr 2.8019.960.0/02

Art./Ref.	Lato/Side	Luci/Lights	Modello/Model
12334	Sx	Luce di direzione e luce di posizione/Direction and position light	COBO 03.212.000
12335	Dx	Luce di direzione e luce di posizione/Direction and position light	COBO 03.213.000

FANALE DIREZIONE- POSIZIONE DX E SX 84X83MM

FEU CLIGNOTANT AVEC FEU DE POSITION 84X83MM
 FRONT LAMP RH & LH 84X83MM
 BLINK-POSITIONSLEUCHTE 84X83MM
 PILOTO DELANTERO 84X83MM

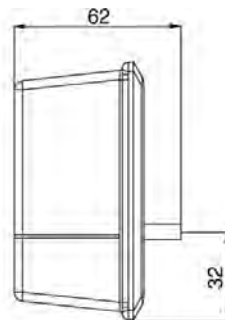
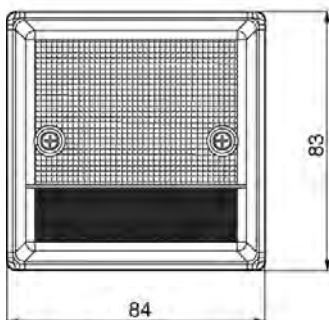

Note: Interasse 45mm
 Lampadine non incluse.
 art. 00441 12V 21W (BA15S)
 per luce di posizione
 art. 00277 12V 5W SILURO 10,5X38 per luce di direzione
 Certificazioni: CE

Notes: Center distance 45mm
 Bulbs not included.
 Pn. 00441 12V 21W (BA15S)
 for position light
 art. 00277 12V 5W 11x35 for direction light
 CE Approved

Art./Ref.	Lato/Side	Luci/Lights	Brand	Ricambio/Replacement
09869	Dx/Sx	Luca di direzione e posizione/Direction and position light	A.M.A.	09859 - rodivetro / front side lamp lens for 09869

FANALE DIREZIONE-POSIZIONE 2 LUCI 188X140MM

FEU CLIGNOTANT AVEC FEU DE POSITION 188X140MM
 FRONT LIGHT WITH 2 FUNCTION 188X140MM
 BLINK-POSITIONSLEUCHTE 188X140MM
 PILOTO DELANTERO 2 FUNCIONES 188X140MM

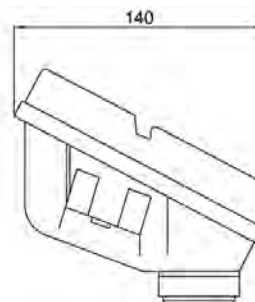
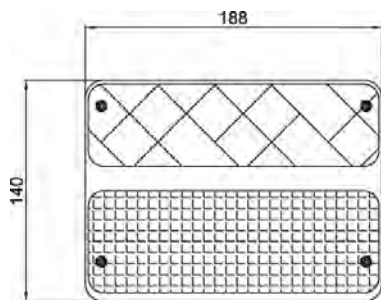

Note: Lampadine non incluse.
 Lampadina per luce di direzione: 00441 12V 21W (BA15S)
 Lampadina per luce di posizione:
 00397 12V 5W (BA15S)
 Omologazione CE
 Adatto a Deutz Fahr 2.8019.180.0

Notes: Bulb not included
 Bulb direction: 00441 12V 21W (BA15S)
 Bulb position light:
 00397 12V 5W (BA15S)
 CE approved
 Suitable Deutz Fahr 2.8019.180.0

Art./Ref.	Lato/Side	Luci/Lights	Modello/Model	Brand	Ricambio/Replacement
00750	Dx/Sx	Luca di direzione e luci di posizione/ Direction and position light	COBO 03.160.000	A.M.A.	00751 - rodivetro fanale art.75o / lens to suit 00750

FANALE DIREZIONE- POSIZIONE 108X103MM

FEU AVANT 108X103MM
 FRONT LAMP 108X103MM
 BLINK-POSITIONSLEUCHTE 108X103MM
 PILOTO DELANTERO 108X103MM

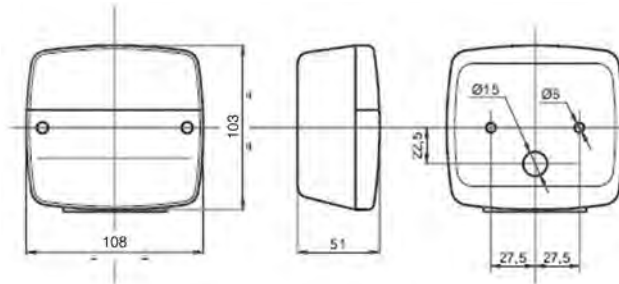

Note: Lampadina per luce di direzione: 00441 12V 21W (BA15S)
 Lampadina per luce di posizione: 00277 12V 5W SILURO 10,5X38
 Interasse di fissaggio 45/55mm fori Ø 5 mm

Notes: Bulb direction: 00441 12V 21W (BA15S)
 Bulb position light: 00277 12V 5W 10,5X38
 Distance between holes 45/55mm Holes Ø 5 mm

Art./Ref.	Lato/Side	Luci/Lights	Brand	Ricambio/Replacement
12531	Dx/Sx	Luce di direzione e luce di posizione/Direction and position light	A.M.A.	12532 - rodovetro x 12531 anterior. / glass for lamp 12531

FANALE DIREZIONE-POSIZIONE 120X75MM CON BASE SAGOMATA

FEU AVANT 120X75MM
 FRONT LAMP 120X75MM
 BLINK-POSITIONSLEUCHTE 120X75MM
 PILOTO DELANTERO 120X75MM



Note: Base sagomata inclinata a 22°, Lampadine non incluse
 Lampadina per luce di direzione: art. 00441 12V 21W (BA15S)
 Lampadina per luce di posizione: art. 00397 12V 5W (BA15S)

Notes: 22° inclined board *Bulb not included*
 Bulb for direction light: pn 00441 12V 21W (BA15S)
 Bulb for position light: pn 00397 12V 5W (BA15S)

Art./Ref.	Lato/Side	Luci/Lights	Brand	Ricambio/Replacement
02862	Dx/Sx	Luce di direzione e luce di posizione/Direction and position light	A.M.A.	00807 - rodovetro adattabile a 1424346m91 / lens for 00464/02862

SUPPORTO IN NYLON STAMPATO CON BASE INCLINATA 22° PER FANALI

SUPPORT EN NYLON INCLINÉ À 22°
 22° INCLINATED SUPPORT NYLON MADE FOR REAR LAMPS
 NYLON - GELENK
 SOPORTE DE NYLON ESTAMPADO CON BASE INCLINATA 22° PARA FAROLES



Art./Ref.	Note/Note	Applicazione/Application
02270	Fanali anteriori/Front lights	00464
04525	Fanali posteriori/Rear lights	02817, 02818

FANALE COMBINATO ANTERIORE/POSTERIORE 120X80MM

FEU AVANTE/ARRIERE 120X80MM

REAR/FRONT LAMP 120X80MM

BLINK-POSITION/SCHLUSS-BREMS-BLINKLEUCHTE 120X80MM

PILOTO DELANTERO Y TRASERO 120X80MM

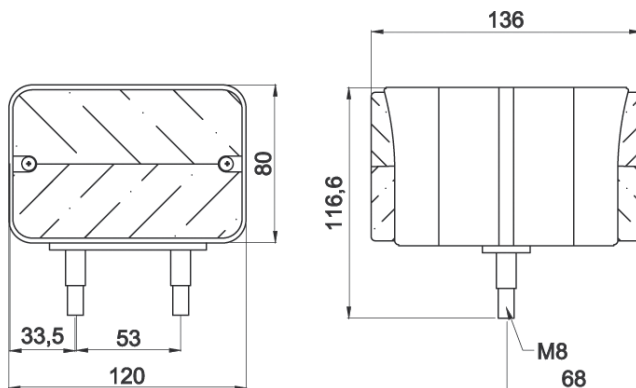
Note: Interasse: 53 mm

Lampadine non incluse.

Art. 00441 2 pz 12V 21W (BA15S)

Per luce di direzione

Art. 00440 1 pz 12V 5/21W (BAY15D) per luce stop

Art. 00397 1 pz 12V 5W SFERICA (BA15S)

per luce di posizione

Certificati: CE

Notes: Centre distance: 53 mm

Bulbs not included

Pn 00441 2 pcs 12V 21W (BA15S)

for direction light

Pn 00440 1 pc 12V 5/21W (BAY15D) for stop light

Pn 00397 1 pc 12V 5W (BA15S)

for position light

CE approved

Art./Ref.	Lato/Side	Luci/Lights	Modello/Model	Ricambio/Replacement
03579	Dx/Sx	Luce di posizione, direzione e stop/Position, direction and stop light	MF 1421316M1	00807 - rodivetro adattabile a 1424346m91 / lens for 00464/02862

FANALE DIREZIONE-POSIZIONE 159X68,5MM

FEU AVANT 159X68,5MM

FRONT LAMP 159X68,5MM

BLINK-POSITIONSLEUCHTE 159X68,5MM

PILOTO DELANTERO 159X68,5MM

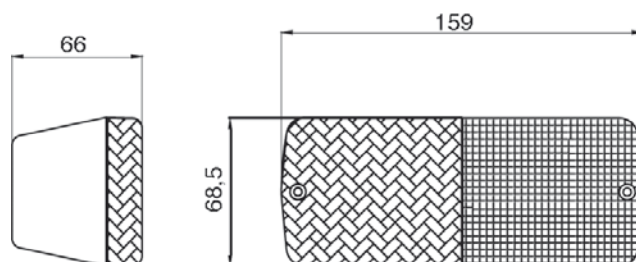
Note: Lente in PC

Lampadine non incluse.

art. 00397 12V 5W SFERICA (BA15S) per luce di posizione

art. 00441 12V 21W (BA15S) per luce di direzione

Notes: PC lens

Bulbs not included

Pn 00397 12V 5W (BA15S) for position light

Pn 00441 12V 21W (BA15S) for direction light

Art./Ref.	Lato/Side	Luci/Lights	Modello/Model	Brand	Ricambio/Replacement
03944	Dx /Sx	Luce di posizione e direzione/Position and direction light	Zetor Antar	A.M.A.	04644 - rodivetro x fanale anteriore / lens for front lights

FANALE ANTERIORE DIREZIONE POSIZIONE 162X70MM

FEU AVANT 162X70MM
 FRONT LAMP 162X70MM
 BLINK-POSITIONSLEUCHTE 162X70MM
 PILOTO DELANTERO 162X70MM



Note: Viti M5
 Lampadine non incluse:
 Art. 00441 12V 21W (BA15S) per luce di direzione
 Art. 00397 12V 5W (BA15S) per luce di posizione
 Certificati: CEE

Notes: M5 screw
Bulbs not included
Pn 00441 12V 21W (BA15S) for direction light
Art. 00397 12V 5W (BA15S) for position light
Certification: ECE

Art./Ref.	Lato/Side	Luci/Lights	Modello/Model	Ricambio/Replacement
02807	Dx /Sx	Luce di posizione, luce di direzione/Position light, direction light	Con base in plastica inclinata	02808 - rodovetro per fanale art.2807 / glass for lamp art. 2807
19799	Dx /Sx	Luce di posizione, luce di direzione /Position light, direction light	-	02808 - rodovetro per fanale art.2807 / glass for lamp art. 2807

FANALE DIREZIONE-POSIZIONE 145X65MM

FEU AVANT 145X65MM
 FRONT LAMP 145X65MM
 BLINK-POSITIONSLEUCHTE 145X65MM
 PILOTO DELANTERO 145X65MM



Note: Lampadina per luce di direzione: art.00441 12V 21W (BA15S)
 Lampadina per luce di posizione: Art. 00397 12V 5W (BA15S)
 Interasse di fissaggio 65mm

Notes: *Bulb direction: Pn 00441 12V 21W (BA15S)*
Bulb position light: Pn 00397 12V 5W (BA15S)
Distance between holes 65mm

Art./Ref.	Lato/Side	Luci/Lights	Brand	Rif. Orig./Orig. Ref.	Ricambio/Replacement
03826	Dx	Luce di direzione e luce di posizione/Direction and position light	FIAT	4247213, 5118463, 5118465	04260 - rodovetro dx per fanale ant.3826 / right lens for lamp 3826
03827	Sx	Direzione e luce di posizione/Direction and position light	FIAT	4247214, 5118464, 5118466	04261 - rodovetro sx per fanale ant.3827 / left lens for lamp 3827

FANALI DIREZIONE-POSIZIONE 160X67MM

FEU AVANT 160X67MM
 FRONT LAMP 160X67MM
 BLINK-POSITIONSLEUCHTE 160X67MM
 PILOTOS DELANTERO 160X67MM

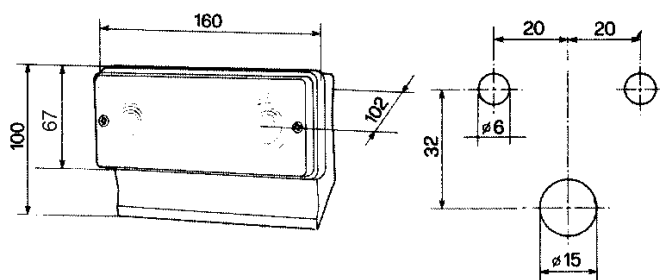

Note: Protezione IP55

Lampadina per luce di direzione: art. 00441 12V 21W (BA15S)

Lampadina per luce di posizione: Art. 00397 12V 5W (BA15S)

Omologazione CE

Notes: Waterproof rate: IP55

Bulb direction: Pn 00441 12V 21W (BA15S)

Bulb position light: Pn 00397 12V 5W (BA15S)

CE approved

Art./Ref.	Lato/Side	Modello/Model	Ricambio/Replacement
02776	Dx	COBO 03.343.000	02858 - rodovetro ant. 2 luci / glass-lamp head 02776
02781	Sx	COBO 03.342.000	02858 - rodovetro ant. 2 luci / glass-lamp head 02776

FANALE DIREZIONE-POSIZIONE 187X83MM

FEU AVANT 187X83MM
 FRONT LAMP 187X83MM
 BLINK-POSITIONSLEUCHTE 187X83MM
 PILOTO DELANTERO 187X83MM

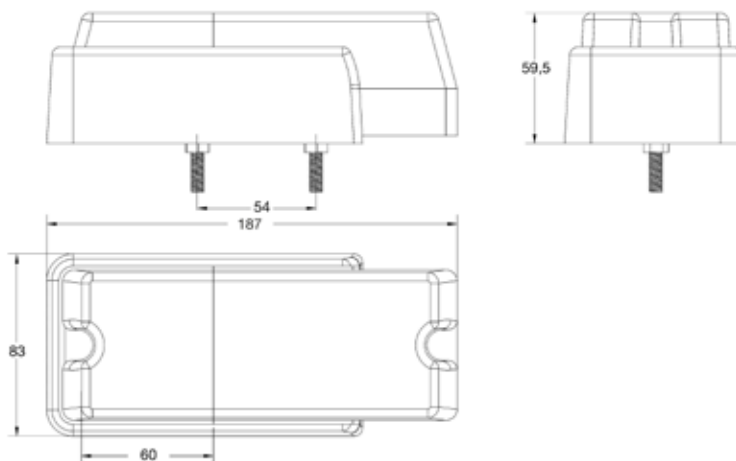

Note: Lente in PC

Lampadine non incluse.

art. 00397 12V 5W SFERICA (BA15S) per luce di posizione

art. 00441 12V 21W (BA15S) per luce di direzione

Notes: PC lens

Bulbs not included

Pn 00397 12V 5W (BA15S) for position light

Pn 00441 12V 21W (BA15S) for direction light

Art./Ref.	Lato/Side	Luci/Lights	Modello/Model
69344	Dx/Sx	Luce di posizione e di direzione/Position light and direction light	Zetor Antar

FANALE DIREZIONE- POSIZIONE 165X60MM

FEU AVANT 165X60MM

FRONT LAMP 165X60MM

BLINK-POSITIONSLEUCHTE 165X60MM

PILOTO DELANTERO 165X60MM



Note: Lampadina per luce di direzione: art. 00441 12V 21W (BA15S)
Lampadina per luce di posizione: art. 00397 12V 5W (BA15S)
Certificato: ECE R6 R7

Notes: Bulb direction: pn 00441 12V 21W (BA15S)
Bulb position light: pn 00397 12V 5W (BA15S)
ECE R6 R7 approved

Art./Ref.	Lato/Side	Luci/Lights	Brand	Applicazione/Application	Rif. Orig./Orig. Ref.	Ricambio/Replacement
02870	Dx	Luca di direzione e luce di posizione/ Direction and position light	LANDINI - FIAT - A.M.A. - NEW HOLLAND	100-90, 110-90 DT, 55-56, 55-66, 55-66 DT, 55-66 DT LP, 55-88 DT, 60-46, 60-46 DT, 60-56 DT, 60-66, 60-66 DT, 60-66 LP, 60-66 LP DT, 60-66S, 60-66S DT, 60-88, 60-90, 60-93 DT, 65-46 DT, 65-66S DT, 65-88 DT, 65-90 DT, 70-56, 70-56 DT, 70-66 LP, 70-66 V, 70-88, 70-90, 70-90 DT, 72-86 LP, 72-86F DT, 72-93, 780, 80-66S, 80-90, 80-90 DT, 82-93, 85-90 DT, 90-90, 90-90 DT, 14500, 5500, 6030, 6500, 6830, 7550, 7830, 9550	5124111, 4999859	02872 - rodovetro dx comp fiat 9933139 / lens for 02870
02871	Sx	Luca di direzione e luce di posizione/ Direction and position light	LANDINI - FIAT - A.M.A. - NEW HOLLAND	100-90 DT, 55-46, 55-46 DT, 55-56 DT, 55-66 LP, 55-66S, 55-66S DT, 55-88, 55-90 DT, 60-90 DT, 60-93, 65-46, 65-56, 65-56 DT, 65-66, 65-66 DT, 65-66S, 65-88, 65-90, 65-93, 65-93 DT, 70-66, 70-66 LP DT, 70-66S, 70-66S DT, 70-76 F DT, 70-76 LP DT, 70-88 DT, 72-86 F, 72-93 DT, 80-66, 80-66 DT, 80-66S DT, 80-88, 80-88 DT, 82-86 LP, 82-93 DT, 88-93 DT, 880, 10000, 12500, 13000, 5830, 8550, 8830	5124114, 4999858, 5124109	02873 - rodovetro sx tip.fiat 9933138* / lens for 02871

1.8.10 Fanali posteriori

Rear light



ama

Ricambi & accessori per macchine agricole

SPARE PARTS & ACCESSORIES FOR AGRICULTURAL MACHINE

Tutti gli articoli della presente sezione, prodotti da AMA SPA e/o da terzi per conto di AMA, sono adattabili ("non originali") alle marche indicate ai sensi di quanto previsto dal REG. CE n. 1400/2002. I diritti sui marchi citati appartengono ai legittimi proprietari ed il loro uso ha l'esclusiva finalità di consentire all'utilizzatore la comparazione dei diversi prodotti. All items of this section, manufactured by AMA SPA and/or any third party on behalf of AMA, are adaptable ("non-original") to the brands listed under the provisions of the REG. CE n. 1400/2002. The rights on the trademarks belong to their respective owners and their usage is only aimed to allow the user to compare different products.

FANALE POSTERIORE A LED 5 FUNZIONI

FEU 5 FONCTIONS LED POUR REMORQUE
LED REAR LIGHT
LED SCHLUSS-BREMS-BLINK LEUCHTE
PILOTO TRASERO LED 5 FUNCIONES



Note: 13,5V · IP67 · Certificato E4 **Notes:** 13,5V · IP67 · E4 approval

Art./Ref.	Lato/Side	Misure/Size	Luci/Lights
75275	Dx/Sx	100x100x40 mm	Luce di posizione, Luce di direzione, Stop, Retro-riflettente, Luce targa/Rear position, Indicator, Stop, Reflector, License plate

FANALE POSTERIORE A LED 12V

FEUX 5 FONCTIONS LED 12V
LED REAR LAMP 12V
SCHLUSS-BREMS-BLINK-LEUCHTE LED 12V
PILOTO TRASERO LED 5 FUNCIONES 12V

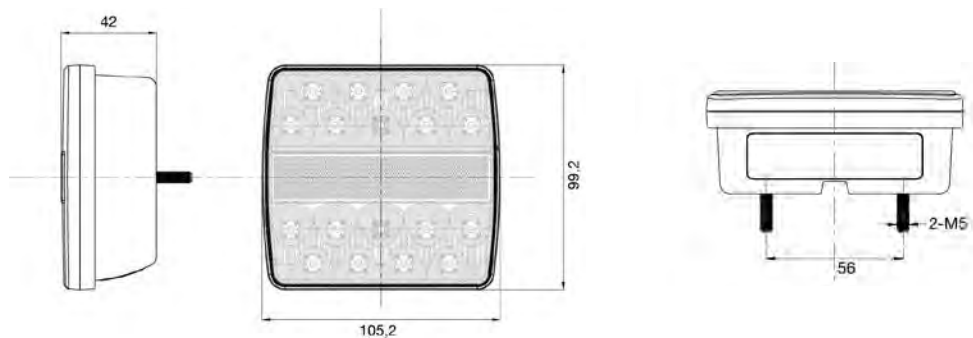

Note: 3W · Lente in PC · Lunghezza cavo 0,35m · Certificazioni: CE ADR **Notes:** 3W · PC lens · Lead lenght 0,35m · ADR E-MARK approval

Art./Ref.	Lato/Side	Luci/Lights
84506	Dx	Luce di direzione, posizione, stop e catarinfrangente/Indicator, tail, stop, reflector
84505	Sx	Luce di direzione, posizione, stop, luce targa e catarinfrangente/Indicator, stop, tail, no. plate, reflector

FANALE POSTERIORE LED 12V

FEUX 4 FONCTIONS LED
LED REAR LAMPS
SCHLUSS-BREMS-BLINK-LEUCHTE LED 12V
PILOTO TRASERO LED 4 FUNCIONES 12V

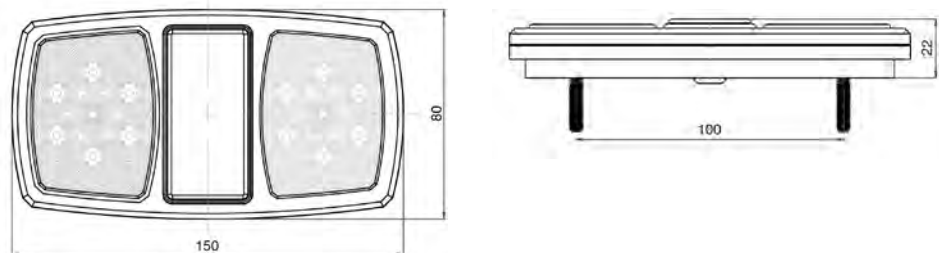

Note: 2,5W · Lunghezza cavo 0,35m · Lente in PC · Certificazioni: CE **Notes:** 2,5W · Lead lenght 0,35m · PC lens · E-MARK Approval

Art./Ref.	Lato/Side	Luci/Lights
84678	Dx	Luce di direzione, posizione, stop e retroriflettente/Indicator, stop, tail, reflector
84679	Sx	Luce di direzione, posizione, stop e catarinfrangente/Indicator, Stop, Tail, Reflector

FANALE POSTERIORE LED DX Ø140MM

FEUX ARRIERE LED DROIT Ø140MM
 RH LED REAR LAMP Ø140MM
 SCHLUSS-BREMS-BLINKLEUCHTE LED Ø140MM
 PILOTO TRASERO LED Ø140MM

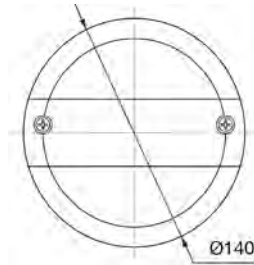

Note: 9-33V · IP67 · Certificati: ECE **Notes:** 9-33V · IP67 · ECE approved

Art./Ref.	Lato/Side	Luci/Lights
76442	Dx	Luce di direzione, Luce di posizione, stop/Postion light, direction light, stop

FANALE POSTERIORE A LED 7 FUNZIONI 10-30V

FEU 7 FONCTIONS LED POUR REMORQUE 10-30V
 LED REAR LIGHT 244X148MM 10-30V
 LED SCHLUSS-BREMS-BLINK LEUCHTE 10-30V
 PILOTO TRASERO LED 7 FUNCIONES 10-30V

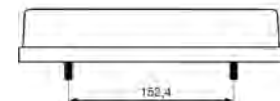
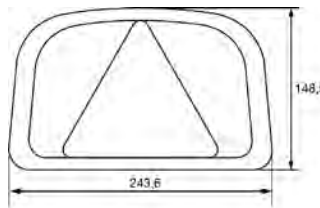

Note: Pre-cablato · IP67 · Interasse 152 mm · Certificato E4 **Notes:** With Cable · IP67 · E4 Approval

Art./Ref.	Lato/Side	Luci/Lights
84494	Dx	Luce di posizione, Luce di direzione, Stop, Retromarcia, Retronebbia, Triangolo riflettente, Luce targa/ Rear position, Direction indicator, Stop, Reversing, Fog, Triangle reflector, Number plate
84495	Sx	Luce di posizione, Luce di direzione, Stop, Retromarcia, Retronebbia, Triangolo riflettente, Luce targa/ Rear position, Direction indicator, Stop, Reversing, Fog, Triangle reflector, Number plate

FANALI POSTERIORI A LED 12V 7 FUNZIONI

FEU 7 FONCTIONS LED POUR REMORQUE 12V
 LED REAR LIGHT 12V
 LED SCHLUSS-BREMS-BLINK LEUCHTE 12V
 PILOTO TRASERO LED 7 FUNCIONES 12V

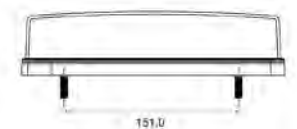
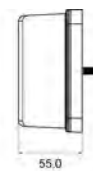
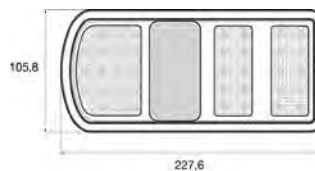

Note: Con connettore · IP67 Certificato · E4 **Notes:** With connector · IP67 E4 · approval

Art./Ref.	Lato/Side	Luci/Lights
84496	Dx	Luce di posizione, Luce di direzione, Stop, Retromarcia, Retronebbia, Catarinfrangente, Luce targa/ Position light, Direction light, Stop, Reversing, Fog, Retro-reflector, License plate
84497	Sx	Luce di posizione, Luce di direzione, Stop, Retromarcia, Retronebbia, Catarinfrangente, Luce targa/ Position light, Direction light, Stop, Reversing, Fog, Retro-reflector, License plate

FANALE POSTERIORE ALOGENO 110X110MM

FEU ARRIERE 4 FONCTIONS 110X110MM
 HALOGEN REAR LAMP 110X110MM
 SCHLUSS-BREMS- BLINKLEUCHTE 110X110MM
 PILOTO TRASERO 4 FUNCIONES 110X110 MM

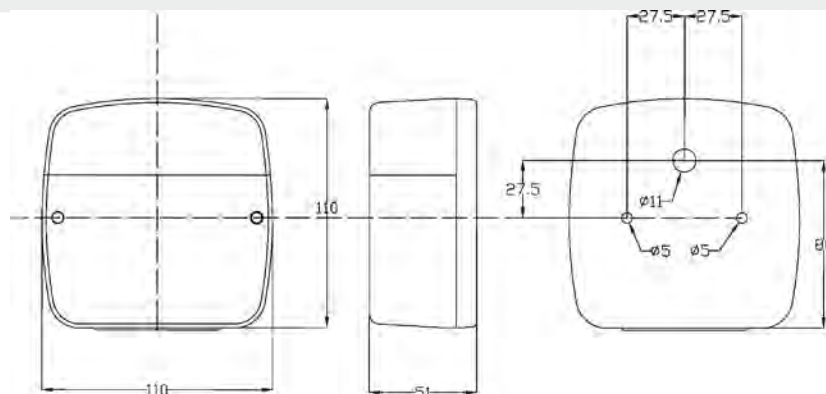

Note: Lampadine non incluse

Art. 00441 2 pz 12V 21W (BA15S) per luce di direzione e stop

Art. 00397 12V 5W (BA15S) per luce di posizione

Fissaggio con viti

Omologato

Notes: Bulbs not included -

Pn. 00441 2 pcs 12V 21W (BA15S) for direction light and stop

Pn. 00397 12V 5W (BA15S) for position light -

Screw fixing

Art./Ref.	Lato/Side	Luci/Lights
84500	Dx	Luce di posizione, luce di direzione, stop/Direction, tail, stop
84501	Sx	Luce di direzione, luce di posizione, luce targa e stop/Direction, tail, no.plate, stop

FANALE ALOGENO POSTERIORE 108X103MM

FEU ARRIERE 4 FONCTIONS 108X103MM
 HALOGEN REAR LIGHT 108X103MM
 SCHLUSS-BREMS- BLINKLEUCHTE 108X103MM
 PILOTO TRASERO IZDO. 4 FUNCIONES 108X103MM

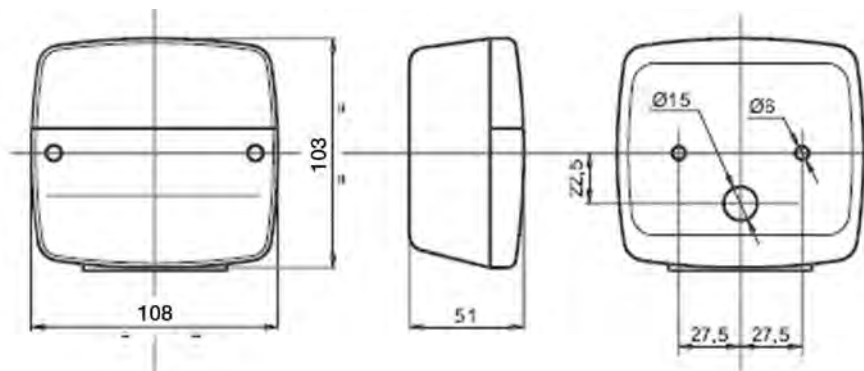

Note: Lampadine non incluse.

art.00441 2 pz 12V 21W (BA15S) per posizione, direzione e stop

art. 00277 12V 5W 10,5X38 per luce targa

Omologazione E3

Notes: Bulbs not included -

pn.00441 2 pcs 12V 21W (BA15S) for position light, stop and direction light

art. 00277 12V 5W 10,5X38dor no. plate light

E3 approval

Art./Ref.	Lato/Side	Luci/Lights	Ricambio/Replacement
02813	Dx	Luce di posizione, luce di direzione e stop/Direction, position and stop	02815 - rodovetro x fan.post 02813/4. / lens to suit 02813/02814/04361
02814	Sx	Luce di posizione, luce di direzione, stop e luce targa/ position light, direction light, stop, no. plate light	02815 - rodovetro x fan.post 02813/4. / lens to suit 02813/02814/04361

FANALE ALOGENO POSTERIORE 100X105MM

FEU ARRIERE 4 FONCTIONS 100X105MM
 HALOGEN REAR LAMP 100X105MM
 SCHLUSS-BREMS-BLINKLEUCHTE 100X105MM
 PILOTO TRASERO 4 FUNCIONES 100X105MM

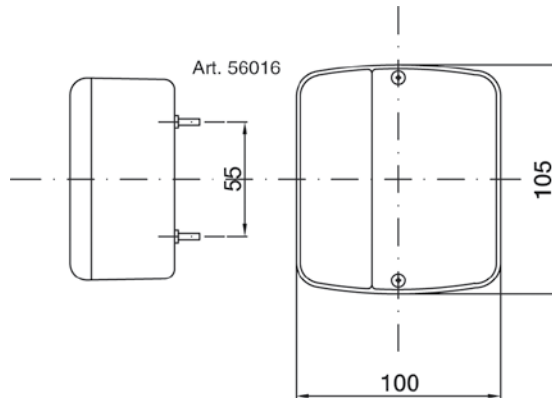

Note: Fissaggio con viti MSX20
 Interasse 45-55mm
 Lampadine non incluse.
 Art. 00441 12V 21W (BA15S) per luce di direzione
 Art. 00440 12V 5/21W (BAY15D) per luce di posizione, luce targa e stop
 Certificati: E3

Notes: M5x20 screw fixing
 Center to center distance 45-55mm
 Bulbs not included -
 Pn. 00441 12V 21W (BA15S) for direction light
 Pn 00440 12V 5/21W (BAY15D) for position light and stop -
 E3 approval

Art./Ref.	Lato/Side	Luci/Lights	Ricambio/Replacement
56016	Dx	Luce di posizione, luce di direzione, stop/ Position light, direction light, stop	39094 - rodov per 56016 e 56017 new / spare part len
56017	Sx	Luce di posizione, luce di direzione, stop, luce targa/ Position light, direction light, stop, no.plate light	39094 - rodov per 56016 e 56017 new / spare part len

FANALE POSTERIORE ALOGENO 100X93MM

FEU ARRIERE 3 FONCTIONS 100X93MM
 HALOGEN REAR LIGHT 100X93MM
 SCHLUSS-BREMS-BLINKLEUCHTE 100X93MM
 PILOTO TRASERO 3 FUNCIONES 100X93MM

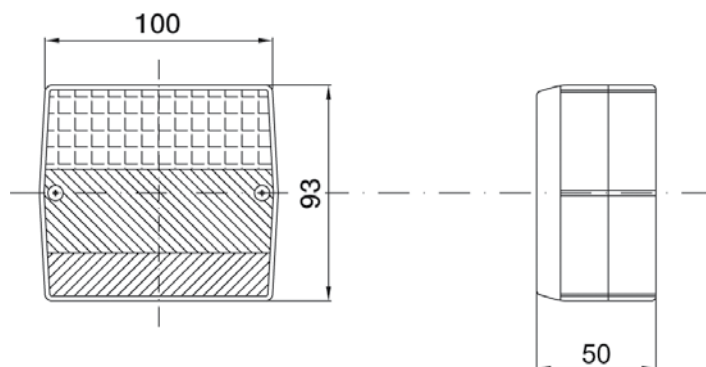
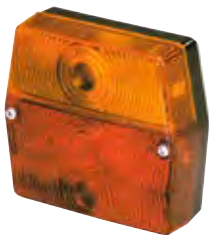

Note: Lampadine non incluse.
 art. 00441 12V 21W (BA15S) per luce di direzione
 art. 00440 12V 5/21W (BAY15D) - per luce di posizione e stop

Notes: Bulb not included
 Pn 00441 12V 21W (BA15S) for direction light
 Pn 00440 12V 5/21W (BAY15D) - for position and stop light

Art./Ref.	Lato/Side	Luci/Lights	Ricambio/Replacement 08643
08641	Dx e Sx	Luce di posizione, luce di direzione, luce targa, stop/Position light, direction light, no. plate light, stop	08643 - rodovetro per fanali / glass for signal light

FANALE ALOGENO POSTERIORE 188X140MM

FEUX 4 FONCTION 188X140MM

HALOGEN REAR LAMP 188X140MM

SCHLUSS-BREMS- BLINKLEUCHTE 188X140MM

PILOTO TRASERO 4 FUNCIONES 188X140MM

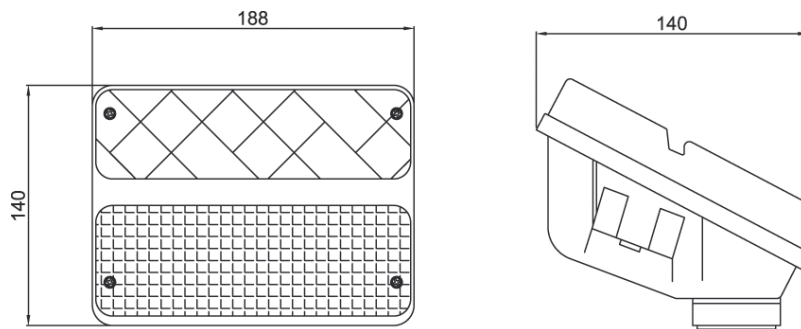
Note: Viti di fissaggio in acciaio

IP65 - Lampadine non incluse.

art. 00441 12V 21W (BA15S) - per Luce di direzione e stop

art. 00397 12V 5W R5W (BA15S) - per luce di posizione e luce targa

Certificati: ECE

Notes: Steel fixing screw

IP65 - Bulbs not included - Pn 00441 12V 21W (BA15S)

for direction light and stop - art. 00397 12V 5W R5W (BA15S)

for position light and no. plate light

ECE approval

Art./Ref.	Lato/Side	Luci/Lights	Tipo/Type	Brand	Applicazione/Application	Rif. Orig./Orig. Ref.	Ricambio/Replacement
02836	Dx	Luce di direzione, luce di posizione, stop/Position light, direction light, stop	COBO 02.285.000	SAME LAMBORGHINI HURLIMANN - A.M.A.	centauro 70 export, centurion 75 export, drago 120, jaguar 100 export, jaguar 95 export, leopard 85, leopard 85 export, leopard 90 turbo, mercury 85 export, panther 90, taurus 60 export, tiger 100, tiger six 105 export, trident 130 export	2.8019.430.0, 2.8019.430.1, 2.8019.740.0	02838 - rodovetro 2/l dx s/l/t / lens to fit 02836
02837	Sx	Luce di direzione, luce di posizione, stop, luce targa/ Position light, direction light, stop, no. plate light	COBO 02.284.000	SAME LAMBORGHINI HURLIMANN - A.M.A.	centauro 70 export, centurion 75 export, drago 120, jaguar 100 export, jaguar 95 export, leopard 85, leopard 85 export, leopard 90 turbo, mercury 85 export, panther 90, taurus 60 export, tiger six 105 export, trident 130 export	2.8019.420.0, 2.8019.420.1, 2.8019.490.0	02839 - rodovetro 2/l sx c/l/t / lens to fit 02837

FANALE ALOGENO POSTERIORE 120X80MM

FEU ARRIERE 3 FONCTIONS 120X80MM

HALOGEN REAR LAMP 120X80MM

SCHLUSS-BREMS- BLINKLEUCHTE 120X80MM

PILOTO TRASERO 3 FUNCIONES 120X80MM

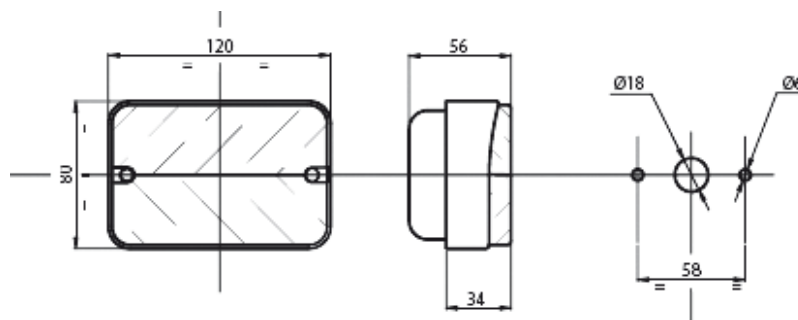
Note: Interasse di montaggio 58mm

Lampadine non incluse

art. 00440 12V 5/21W (BAY15D) per luce di posizione e stop

Art. 00441 12V 21W (BA15S) per luce di direzione

Certificazioni: CEE

Notes: Attachment center to center 58mm

Bulbs not included

Pn 00440 12V 5/21W (BAY15D) for position light and stop

Pn 00441 12V 21W (BA15S) for direction light

CEE approval

Art./Ref.	Lato/Side	Luci/Lights	Brand	Applicazione/Application	Rif. Orig./Orig. Ref.	Ricambio/Replacement
02950	Dx /Sx	Luce di posizione, Luce di direzione, stop/ Position light, direction light, stop	SAME LAMBORGHINI HURLIMANN - LANDINI - A.M.A.	advantage 3 cyl, advantage 4 cyl, advantage vigneti, alpine, alpine tier 3, cingolati meccanici, frutteti 530 f-l-v, frutteti 560 f-l-v, globus, legend, rex foot step, technofarm, trekker, trekker new, explorer 65 c, explorer 70 c ergonomic, explorer c, fox 35, fox 45, krypton, krypton com 3, krypton f, rock, solar 55 c, solar 60 c, solar 60 compact hd, solaris, solaris com 3	3310349M91, 2.8019.800.0	02951 - rodovetro x fanale 2950-3579 / lens to suit 02950

FANALE ALOGENO POSTERIORE 120X79MM

FEUX 3 FONCTIONS 120X79MM
 HALOGEN REAR LAMP 120X79MM
 SCHLUSS-BREMS- BLINKLEUCHTE 120X79MM
 PILOTO TRASERO 3 FUNCIONES 120X79MM

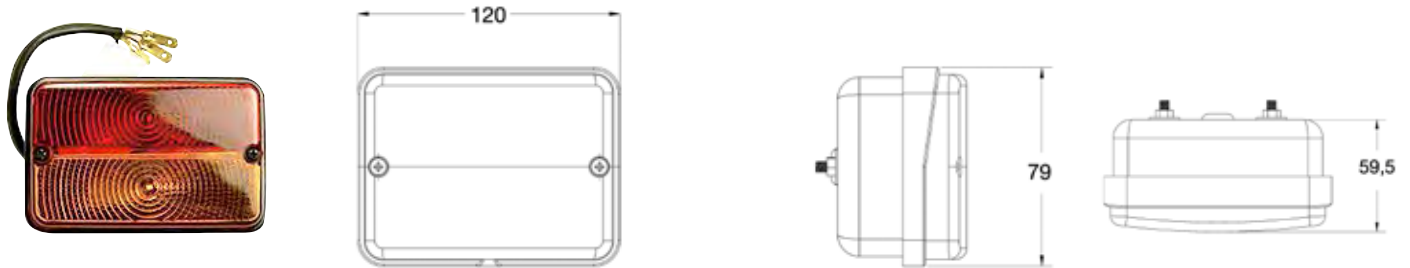

Note: Interasse di fissaggio 58,5mm
 Viti M5
 Lampadine non incluse
 Art. 00441 12V 21W (BA15S) - per luce di direzione
 Art. 00440 12V 5/21W (BAY15D) - per luce di posizione e stop

Notes: Center to center distance 58,5mm
 M5 screw
 Bulbs not included
 Pn 00441 12V 21W (BA15S) - for direction light
 Pn 00440 12V 5/21W (BAY15D) - for position light and stop

Art./Ref.	Lato/Side	Luci/Lights	Ricambio/Replacement
69340	Dx /Sx	Luce di posizione, luce di direzione, stop/ Position light, direction light, stop	02951 - rodovetro x fanale 2950-3579 / lens to suit 02950

FANALI POSTERIORI ALOGENI ROTONDI

PHARE ARRIERE 4 FONCTIONS
 HALOGEN REAR LIGHTS
 SCHLUSS-BREMS- BLINKLEUCHTE
 PILOTO TRASERO 4 FUNCIONES

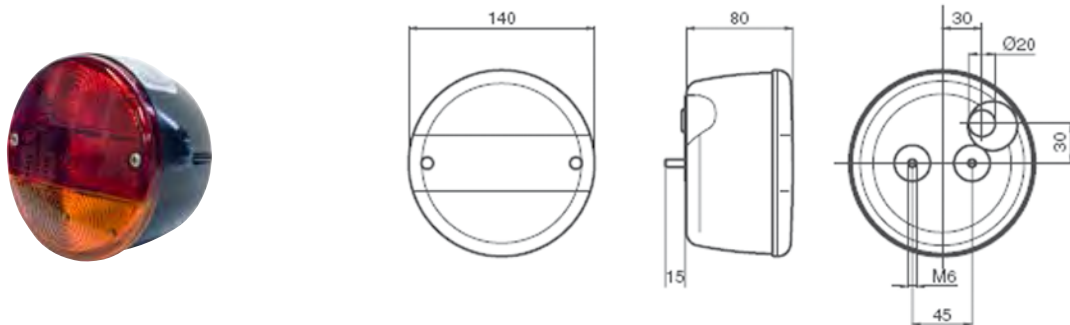

Note: Lampadine non incluse
 art.00441 2 pz 12V 21W (BA15S) per luce di direzione e stop
 art. 00397 1 pz 2V 5W (BA15S) per luce di posizione

Notes: Bulbs not included
 Pn.00441 2 pcs 12V 21W (BA15S) for direction light and stop
 Pn. 00397 1 pc 2V 5W (BA15S) for position light

Art./Ref.	Lato/Side	Luci/Lights	Specifiche/Specifications	Tipo/Type	Ricambio/Replacement
02906	Dx	Luce di posizione, luce di direzione, stop/ Position light, direction light, stop	Ø140mm		02909 - rodovetro x fanali 2906/2907 / lens for 02906/02907
02907	Sx	Luce di direzione, luce di posizione, stop, luce targa/ Direction light, position light, stop, no. plate light	Ø140mm		02909 - rodovetro x fanali 2906/2907 / lens for 02906/02907
02932	Dx	Luce di posizione, luce di direzione, stop/ Position light, direction light, stop	ø115 mm	COBO 02.261.000	02934 - rodovetro x fanali 2932/2933 / glass for lamp
02933	Sx	Luce di direzione, luce di posizione, stop, luce targa/ Direction light, position light, stop, no. plate light	ø115 mm	COBO 02.260.000	02934 - rodovetro x fanali 2932/2933 / glass for lamp

FANALE ALOGENO POSTERIORE 185X75MM

FEUX ARRIERE 185X75MM

HALOGEN REAR LIGHT 185X75MM

SCHLUSS-BREMS- BLINKLEUCHTE 185X75MM

PILOTO TRASERO 185X75MM

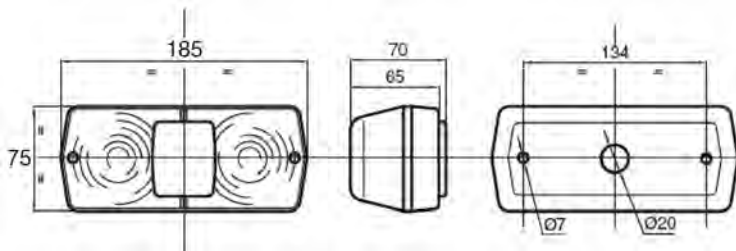
Note: Interasse 55 mm

Lampadine non incluse

art. 00440 12V 5/21W (BAY15D) - per luce di posizione e stop

art. 00441 12V 21W (BA15S) - per luce di direzione

Notes: Center to center distance 55 mm

Bulbs not included

Pn 00440 12V 5/21W (BAY15D) for position light and stop

Pn 00441 12V 21W (BA15S) for direction light

Art./Ref.	Lato/Side	Luci/Lights	Ricambio/Replacement
03976	Dx /Sx	Luce di posizione, luce di direzione, stop/Position light, direction light, stop	04658 - rodivetro dx x fan.post.s/cat. / r ight lens for rear lamp
03942	Dx /Sx	Luce di posizione, luce di direzione, stop, catarinfrangente/Position light, direction light, stop, reflector	04633 - rodivetro dx x fan.post.c/cat. / lens for 03942

FANALE POSTERIORE

PHARE ARRIERE

REAR LIGHT

RÜCKLEUCHTEN

FAROL POSTERIOR

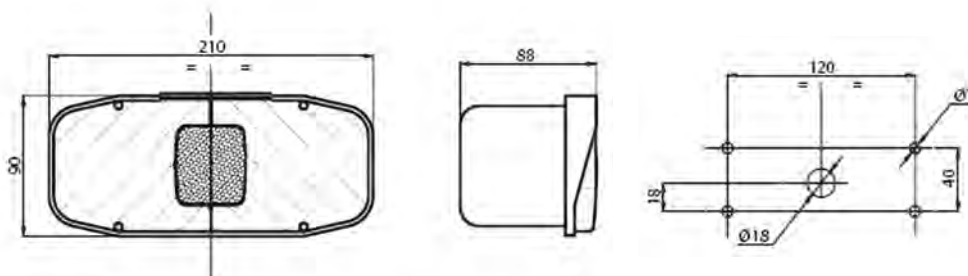
Note:

Art. 00440 1 pz 12V 5/21W (BAY15D) per luce di posizione, stop e luce targa -

Art. 00441 1 pz 12V 21W (BA15S) per luce di direzione

Notes:

Pn. 00440 1 pz 12V 5/21W (BAY15D) for position light, no.plate light and stop

Pn. 00441 1 pz 12V 21W (BA15S) for direction light

Art./Ref.	Lato/Side	Luci/Lights	Fissaggio/Fissaggio	Brand	Applicazione/Application	Rif. Orig./Orig. Ref.	Ricambio/Replacement
16165	Dx	Luce di direzione, luce di posizione, stop/Direction light, position light, stop	Viti/Screw	FIAT - A.M.A.	3300al mietitrebbie laverda, 3400 mietitrebbie laverda, 3400r mietitrebbie laverda, 3500 mietitrebbie laverda, 3500r mietitrebbie laverda, 3550 mietitrebbie laverda, 3550al mietitrebbie laverda, 3550r mietitrebbie laverda, 3650 mietitrebbie laverda, 3650r mietitrebbie laverda, 3750 mietitrebbie laverda, 3750r mietitrebbie laverda, 3790 mietitrebbie laverda, 3790r mietitrebbie laverda, 3850 mietitrebbie laverda, 3850r mietitrebbie laverda, 3890 mietitrebbie laverda, 3890r mietitrebbie laverda	311282300, 311282700, 311531000, 321204900	16167 - corpo luminoso adattabile a 321205150 / revolution-counter cable
16166	Sx	Luce di direzione, luce di posizione, stop, luce targa/Direction light, position light, stop, no. plate light	Viti /Screw	FIAT - A.M.A.	3300al mietitrebbie laverda, 3400 mietitrebbie laverda, 3400r mietitrebbie laverda, 3500 mietitrebbie laverda, 3500r mietitrebbie laverda, 3550 mietitrebbie laverda, 3550al mietitrebbie laverda, 3550r mietitrebbie laverda, 3650 mietitrebbie laverda, 3650r mietitrebbie laverda, 3750 mietitrebbie laverda, 3750r mietitrebbie laverda, 3790 mietitrebbie laverda, 3790r mietitrebbie laverda, 3850 mietitrebbie laverda, 3850r mietitrebbie laverda, 3890 mietitrebbie laverda, 3890r mietitrebbie laverda	311282301, 311282701, 313782800, 321205000	16167 - corpo luminoso adattabile a 321205150 / revolution-counter cable

FANALE ALOGENO POSTERIORE 184X79MM

FEUX 3 FONCTIONS 184X79MM
 HALOGEN REAR LAMP 184X79MM
 SCHLUSS-BREMS- BLINKLEUCHTE 184X79MM
 PILOTO TRASERO 3 FUNCIONES 184X79MM

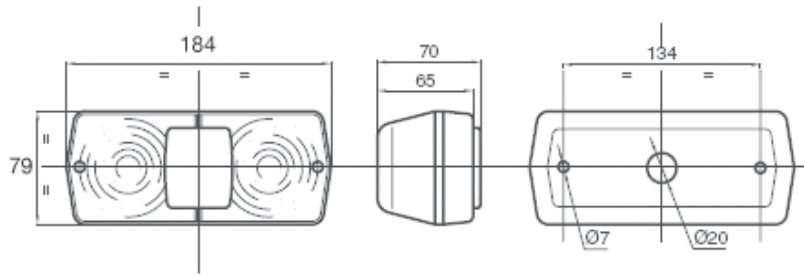

Note:
 Interasse di fissaggio 51mm
 Viti M5
 Lampadine non incluse
 Art. 00441 12V 21W (BA15S) per luce di direzione
 Art. 00440 12V 5/21W (BAY15D) per luce di posizione e stop

Notes:
 Center to center distance 51mm
 M5 screw
 Bulbs not included
 Pn 00441 12V 21W (BA15S) for direction light
 Pn 00440 12V 5/21W (BAY15D) for position light and stop

Art./Ref.	Lato/Side	Luci/Lights	Brand	Applicazione/Application	Rif. Orig./Orig. Ref.	Ricambio/Replacement
02953	Dx	Luce di posizione, luce di direzione, stop/Position light, direction light, stop	LANDINI - A.M.A. - MASSEY FERGUSON	FRUTTETI 530: 6530L, FRUTTETI 530: 8530F, FRUTTETI 530: 8530L, 174 F, 194 F, 230, 240, 243, 250, 253/263, 265, 275, 275/375 E, 290, 290/390 E, 298, 340, 374 F - H, 374 SP - FP - AP - GE, 375 E, 390 E, 394 F - H, 394 SP - FP - AP - GE	1678869M91, 1678869M91, 1678869M92	02955 - rodovetro x fanale 2953-2954 / lens for lamp no.02953/02954
02954	Sx	Luce di posizione, luce di direzione, stop/Position light, direction light, stop	LANDINI - A.M.A. - MASSEY FERGUSON	FRUTTETI 530: 6530L, FRUTTETI 530: 8530F, FRUTTETI 530: 8530L, 174 F, 194 F, 230, 240, 243, 250, 253/263, 265, 275, 275/375 E, 290, 290/390 E, 298, 340, 374 F - H, 374 SP - FP - AP - GE, 375 E, 390 E, 394 F - H, 394 SP - FP - AP - GE	1678868M91, 1678868M91, 1678868M92	02955 - rodovetro x fanale 2953-2954 / lens for lamp no.02953/02954

FANALE ALOGENO POSTERIORE 160X68MM

FEUX 3 FONCTIONS 160X68MM
 HALOGEN REAR LAMP 160X68MM
 SCHLUSS-BREMS- BLINKLEUCHTE 160X68MM
 PILOTO TRASERO 3 FUNCIONES 160X68MM

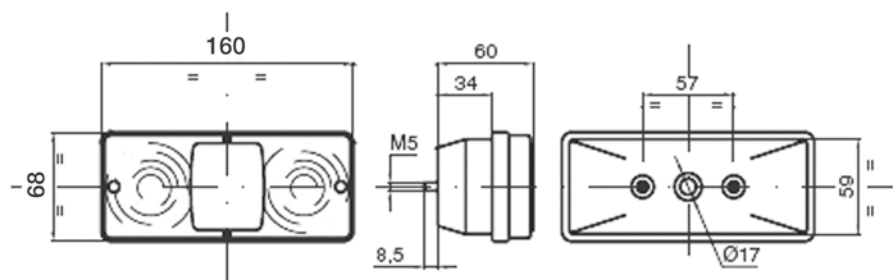

Note:
 Interasse di fissaggio 57,5 mm
 Viti M5
 Lampadine non incluse
 Art. 00441 12V 21W (BA15S) per luce di direzione
 Art. 00440 12V 5/21W (BAY15D) per luce di posizione e stop

Notes:
 Center to center distance 57,5mm
 M5 screw
 Bulbs not included
 Pn 00441 12V 21W (BA15S) for direction light
 Pn 00440 12V 5/21W (BAY15D) for position light and stop

Art./Ref.	Lato/Side	Luci/Lights	Ricambio/Replacement
06112	Dx-Sx	Luce di posizione, luce di direzione, stop/ Position light, direction light, stop	02856 - rodovetro 3 luci dx / glass-lamp 3-lights right

FANALE POSTERIORE ALOGENO 162X70MM

FEU ARRIERE 4 FUNCTION 162X70MM
 HALOGEN REAR LAMP 162X70MM
 SCHLUSS-BREMS- BLINKLEUCHTE 162X70MM
 PILOTO TRASERO 4 FUNCIONES 162X70MM

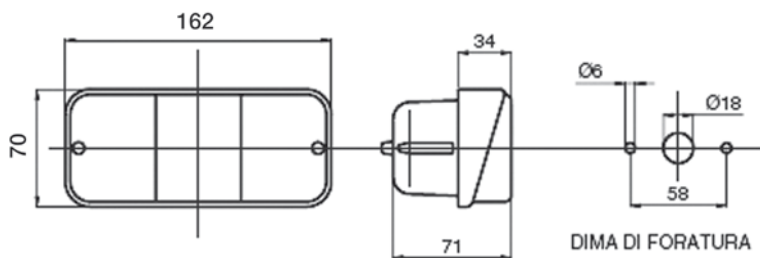
Note:

Viti M4
 Lampadine non incluse.
 art. 00441 2 pz 12V 21W (BA15S) per luce di direzione e stop
 art. 00397 1 pz 12V 5W (BA15S) per luce di posizione
 Certificazioni: CEE

Notes:

M4 screw
 Bulbs not included
 Pn. 00441 2 pcs 12V 21W (BA15S) for direction light and stop
 Pn. 00397 1 pc 12V 5W (BA15S) for position light
 CEE approval

Art./Ref.	Lato/Side	Luci/Lights	Specifiche/Specifications	Ricambio/Replacement
02817	Dx	Luce di posizione, Luce di direzione, stop/ Direction light, position light, stop		02819 - rodivetro post.3/l dx x 02822 / rear lens r/h suit 02817/02822
02818	Sx	Luce di posizione, Luce di direzione, stop. luce targa/ Position light, direction light, stop, no. plate light		02820 - rodivetro post.3/l sx x 02823 / l/h lens suit 02823/02818
02822	Dx	Luce di posizione, Luce di direzione, stop/ Direction light, position light, stop	Con base inclinata in plastica - art. 04525	02819 - rodivetro post.3/l dx x 02822 / rear lens r/h suit 02817/02822
02823	Sx	Luce di posizione, Luce di direzione, stop. luce targa/ Position light, direction light, stop, no. plate light	Con base inclinata in plastica - art. 04525	02820 - rodivetro post.3/l sx x 02823 / l/h lens suit 02823/02818

FANALE POSTERIORE ALOGENO 158X51MM

FEUX 3-4 FONCTIONS 158X51MM
 HALOGEN REAR LAMP 158X51MM
 SCHLUSS-BREMS- BLINKLEUCHTE 158X51MM
 PILOTO TRASERO 3-4 FUNCIONES 158X51MM

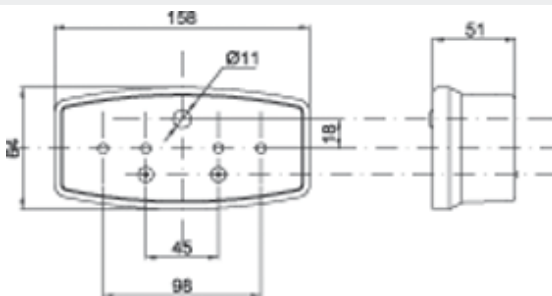
Note:

Fanale 12-24V
 Lampadine non incluse
 art. 03874 2 pz 12V 10W BA15S
 art. 00441 2 pz 12V 21W (BA15S)
 Certificazioni: E1 130, E1 22831, E1 53253

Notes:

Voltage: 12-24V
 Bulbs not included
 Pn 03874 2 pcs 12V10W BA15S
 Pn 00441 2 pcs 12V 21W (BA15S)
 E1 130, E1 22831, E1 53253 Approval

Art./Ref.	Lato/Side	Luci/Lights	Tipo/Type	Brand	Applicazione/Application
37337	Dx	Luce di posizione, Luce di direzione, stop/Position light, direction light, stop	HELLA 2SD0031840041	DAF - LANDINI - DEUTZ - NEOPLAN - JOHN DEERE - KASSBOHRER - FAUN - MAN - AUWARTER - FENDT - KUBOTA - HELLA - FORD - SCHMITZ CARGOBULL	11025268, 11025300, 1503.208.00, 1503.232.00, 086 7487, 043 49207/10, 5231-599, F231GT, F265GT, F275 GT, F345GT, F345GTA, F360 GHA, 3 227 655 0, 50 51 70, 7 526 123 000, 7.525.123.000, 7.526.123.000.0, TA04930010, GT, N1.01102-5268, 1503.208.00, 1503.232.00, 36.25225-6009, 060974, 1094
36572	Sx	Luce di posizione, luce di direzione, stop, luce targa/Position light, direction light, stop, no. plate light	HELLA 2SE003184011	FENDT- DEUTZ	043 49205/10, 102 S, 103 S, 104 S, 105 S, 106 S, 108 S, 200 S, 201S, 303 LS

FANALE ALOGENO POSTERIORE 209X73,5MM

FEUX 3 FONCTIONS 209X73,5MM
 HALOGEN REAR LAMP 209X73,5MM
 SCHLUSS-BREMS- BLINKLEUCHTE 209X73,5MM
 PILOTO TRASERO 3 FUNCIONES 209X73,5MM

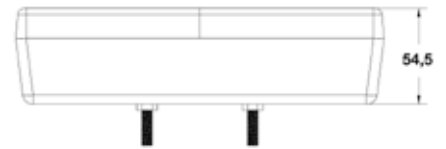
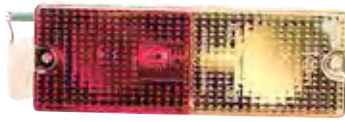

Note:
 Interasse di fissaggio 60 mm
 Viti M6
 Lampadine non incluse
 Art. 00441 12V 21W (BA15S) per luce di direzione
 Art. 00440 12V 5/21W (BAY15D) per luce di posizione e stop

Notes:
 Center to center distance 60 mm
 M6 screw
 Bulbs not included
 Pn 00441 12V 21W (BA15S) for direction light
 Pn 00440 12V 5/21W (BAY15D) for position light and stop

Art./Ref.	Lato/Side	Luci/Lights
69342	Dx-Sx	Luce di posizione, luce di direzione, stop/Position light, direction light, stop

FANALE POSTERIORE 145X65MM

FEUX ARRIERE 145X65MM
 REAR LAMP 145X65MM
 SCHLUSS-BREMS- BLINKLEUCHTE 145X65MM
 PILOTO TRASERO 145X65MM

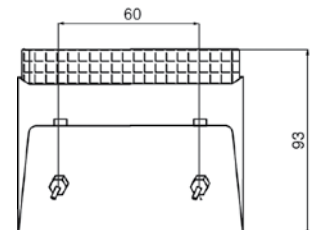
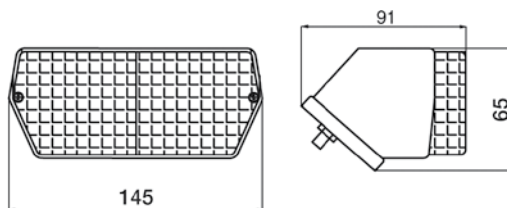

Note:
 Lampadine non incluse
 Art. 00441 12V 21W (BA15S) per luce di direzione
 Art. 00440 12V 5/21W (BAY15D) per luce di posizione, luce targa e stop
 Certificazioni: ECE

Notes:
 Bulbs not included
 Pn. 00441 12V 21W (BA15S) for direction light
 Pn. 00440 12V 5/21W (BAY15D) for position light, number plate light, stop
 ECE approval

Art./Ref.	Lato/Side	Luci/Lights	Brand	Applicazione/ Application	Rif. Orig./ Orig. Ref.	Ricambio/ Replacement
12015	Dx	Luce di posizione, luce di direzione, stop/ Position light, direction light, stop	FIAT		4247208	
12014	Sx	Luce di posizione, luce di direzione, stop, luce targa/ Position light, direction light, stop, no. plate light	FIAT		4243629	
02880	Dx	Luce di posizione, luce di direzione, stop e catarinfrangente 3.0/ Position light, direction light, stop and reflector 3.0	FIAT - A.M.A.	1000, 1300, 420, 470, 480, 640, 650, 750, 850, 855, 905, 955	4247207, 4270426, 4270427, 5118454	02883 - rodivetro dx / replacemet lens
02881	Sx	Luce di posizione, luce di direzione, stop, luce targa e catarinfrangente 3.0/ Position light, direction light, stop, number plate lighe and reflector 3.0	FIAT - A.M.A.	1000, 1300, 420, 470, 480, 640, 650, 750, 850, 855, 905, 955	4247203, 4270477, 4270478, 5118468	02884 - rodivetro sx / replacement lens

FANALE ALOGENO POSTERIORE 160X67MM

FEUX 4 FONCTION 160X67MM

HALOGEN REAR LAMP 160X67MM

SCHLUSS-BREMS- BLINKLEUCHTE 160X67MM

PILOTO TRASERO 4 FUNCIONES 160X67MM

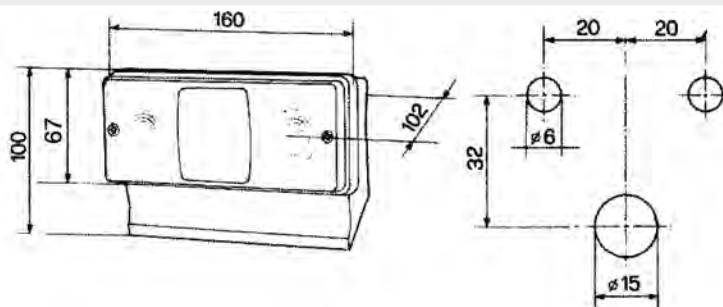
Note:

Viti di fissaggio M5 acciaio zincato

IP55

Lampadine non incluse

art. 00440 12V 5/21W (BAY15D) per luce di posizione e stop

art. 00441 2V 21W (BA15S) per luce di direzione

Certificazioni: ECE

Notes:

M5 zinc-plated steel fixing screw

IP55

Bulbs not included

Pn. 00440 12V 5/21W (BAY15D) for position light and stop

Pn. 00441 2V 21W (BA15S) for direction light

ECE approval

Art./Ref.	Luci/Lights	Lato/Side	Tipo/Type	Ricambio/Replacement
02851	Luce di direzione, luce di posizione, stop e catarinfrangente/ Direction light, position light, stop and reflector	Dx	COBO 02.753.000	02856 - rodivetro 3 luci dx / glass-lamp 3-lights right
02852	Luce di direzione, luce di posizione, stop e catarinfrangente/ Direction light, position light, stop and reflector	Sx	COBO 02.754.000	02856 - rodivetro 3 luci dx / glass-lamp 3-lights right

FANALE ALOGENO POSTERIORE 185X85MM

FEUX 3 FONCTION 185X85MM

HALOGEN REAR LAMP 185X85MM

SCHLUSS-BREMS- BLINKLEUCHTE 185X85MM

PILOTO TRASERO 3 FUNCIONES 185X85MM

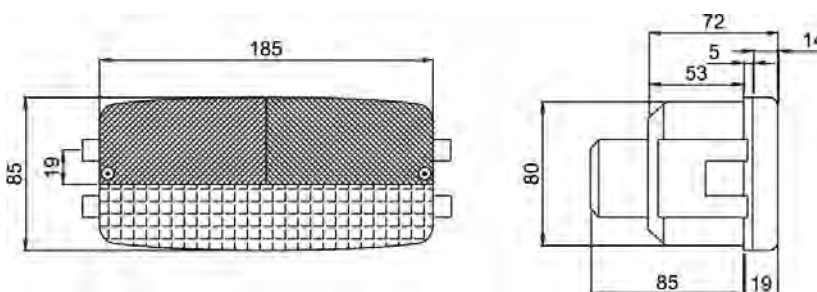
Note:

Viti di fissaggio M5 acciaio zincato

IP55

Lampadine non incluse

00440 12V 5/21W (BAY15D) per luce di posizione

art. 00441 2V 21W (BA15S) per luce di direzione e stop

Certificazioni: ECE

Notes:

M5 zinc-plated steel fixing screw

IP55

Bulbs not included

Pn. 00440 12V 5/21W (BAY15D) - for position light

Pn. 00441 2V 21W (BA15S) for direction light and stop

ECE approval

Art./Ref.	Lato/Side	Luci/Lights	Tipo/Type	Brand	Applicazione/Application	Rif. Orig./Orig. Ref.	Ricambio/Replacement
06573	Dx	Luce di direzione, luce di posizione, stop/Direction light, position light, stop	COBO 02.487.000	SAME LAMBORGHINI HURLIMANN	antares, explorer, explorer com 3, explorer ii, explorer ii special, explorer special, explorer t-tb, explorer t-tb com 3, laser, row crop, silver	2.8059.090.0	06575 - rodivetro dx same 2.8059.090.01 / right glass/ light art.06573
06572	Sx	Luce di direzione, luce di posizione, stop/Direction light, position light, stop	COBO 02.486.000	SAME LAMBORGHINI HURLIMANN - A.M.A.	antares, explorer, explorer 55 - 60, explorer com 3, explorer ii, explorer ii special, explorer special, explorer special 65, explorer special 70, explorer special 75, explorer special 80, explorer t-tb, explorer t-tb com 3, laser, row crop, silver, solar 60	2.8059.080.0	06574 - rodivetro sx same 2.8059.080.01 / left glass for light art. 6572

FANALE ALOGENO POSTERIORE 303X130MM

FEUX 4 FONCTION 303X130MM
 HALOGEN REAR LAMP 303X130MM
 SCHLUSS-BREMS- BLINKLEUCHTE 303X130MM
 PILOTO TRASERO 4 FUNCIONES 303X130MM

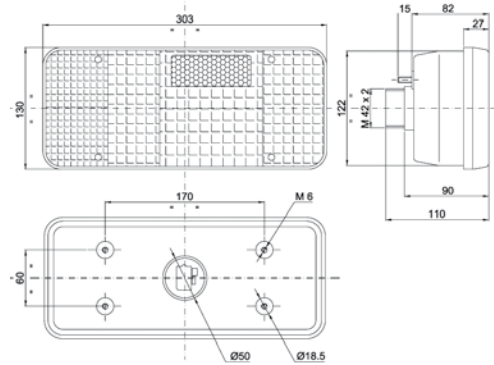

Note:
 Interasse 170mm, viti M6
 Lampadine non incluse
 Art. 00441 3 pz 12V 21W (BA15S) - per luce di direzione, stop, retromarcia/retronebbia
 Art. 00397 1 pz 12V 5W (BA15S) per luce di posizione
 Certificazioni: CEE

Notes:
 Center to center distance 170mm, M6 screw
 Bulbs not included
 Pn 00441 3 pcs 12V 21W (BA15S) for direction light, stop, reversing/fog light
 Pn 00397 1 pcs 12V 5W (BA15S) - for position light
 Certification: CEE

Art./Ref.	Lato/Side	Luci/Lights	Ricambio/Replacement
27230	Dx	Luce di posizione, luce di direzione, stop, retromarcia/ Position light, direction light, stop, reversing light	27231 - rodivetro per 27230 / lens for 27230 lamp
27232	Sx	Luce di direzione, luce di posizione, stop, retronebbia/ Direction light, position light, stop, fog	27233 - rodivetro per 27232 / rear lens

FANALE POSTERIORE ALOGENO 305X62MM

FEUX 4 FONCTIONS 305X62MM
 HALOGEN REAR LAMPS 305X62MM
 SCHLUSS-BREMS- BLINKLEUCHTE 305X62MM
 PILOTO TRASERO 3 FUNCIONES 305X62MM

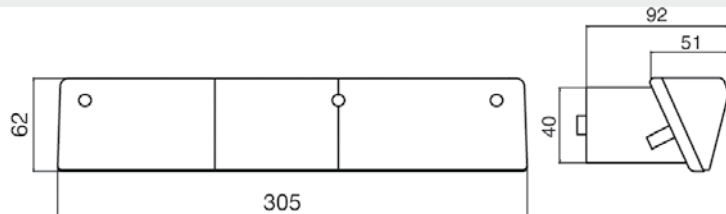

Note:
 Lampadine non incluse
 Art. 00441 2 pz 12V 21W (BA15S) per luce di direzione e stop
 Art. 00397 12V 5W (BA15S) per luce di posizione
 Certificazioni: ECE R6 R7

Notes:
 Bulbs not included
 Pn. 00441 2 pcs 12V 21W (BA15S) for direction light and stop
 Pn. 00397 12V 5W (BA15S) for position light
 Certifications: CEE, R6 R7

Art./Ref.	Lato/Side	Luci/Lights	Brand	Applicazione/Application	Rif. Orig./Orig. Ref.	Ricambio/Replacement
02891	Dx	Luce di posizione, luce di direzione, stop/Position light, direction light, stop	LANDINI - FIAT - A.M.A. - MASSEY FERGUSON - FORD	100-90, 110-90, 115-90 DT, 130-90 DT, 140-90 DT, 160-90, 160-90 DT, 180-90, 180-90 DT, 45-66, 45-66 DT, 50-66, 50-66S DT, 55-46, 55-46 DT, 55-56S DT, 55-66 DT LP, 55-88, 55-90, 55-90 DT, 56-66S, 60-46, 60-46 DT, 60-56 DT, 60-66 LP, 60-66 LP DT, 60-88, 60-88 DT, 60-90, 60-93, 60-93 DT, 65-46, 65-66 DT, 65-66S, 65-66S DT, 65-90 DT, 65-93 DT, 65-94 DT, 70-66 DT, 70-66 V, 70-76 LP, 70-88, 70-90 DT, 72-86 F, 72-86F DT, 72-94, 72-94 DT, 80-66, 80-66 DT, 80-66S DT, 80-88, 80-88 DT, 80-90, 80-90 DT, 82-86 LP, 82-94, 85-90, 880, 90-90 DT, 8830, 10000, 12500, 13000, 5500, 6500, 7830, 8550, 1004 T-1004, 1024, 264, 273, 283, 294 S - 294, 675, 690, 698 T - 698, 699	4997267, 5124117	02893 - rod dx compati tibi fiat 9929835 / lens for 02891
02892	Sx	Luce di posizione, luce di direzione, stop, luce targa/ Position light, direction light, stop, no. plate light	LANDINI - FIAT - A.M.A. - MASSEY FERGUSON	100-90 DT, 110-90 DT, 115-90, 130-90, 140-90, 45-66S, 45-66S DT, 50-66 DT, 50-66S, 55-56, 55-56 DT, 55-56S, 55-66, 55-66 DT, 55-88 DT, 60-66, 60-66 DT, 60-66S, 60-66S DT, 60-90 DT, 65-46 DT, 65-56, 65-56 DT, 65-66, 65-88, 65-88 DT, 65-90, 65-93, 65-94, 70-56, 70-56 DT, 70-66, 70-66 LP, 70-66 LP DT, 70-66S, 70-66S DT, 70-76 LP DT, 70-88 DT, 70-90, 72-86 LP, 72-93, 72-93 DT, 80-66S, 82-93, 82-93 DT, 82-94 DT, 85-90 DT, 88-93, 88-93 DT, 88-94, 88-94 DT, 90-90, 14500, 5830, 6030, 6550, 6830, 7550, 8830, 9550, 1014, 1114, 1134, 154, 174, 233, 253, 254, 263, 274 SK - 274, 284 S - 284	-	02894 - rod sx compati tib.fiat 9929834* / lens lh for 02892

FANALI ALOGENI POSTERIORI

FEUX 3 FONCTIONS
 HALOGEN REAR LAMPS
 SCHLUSS-BREMS- BLINKLEUCHTE
 PILOTO TRASERO 3 FUNCIONES

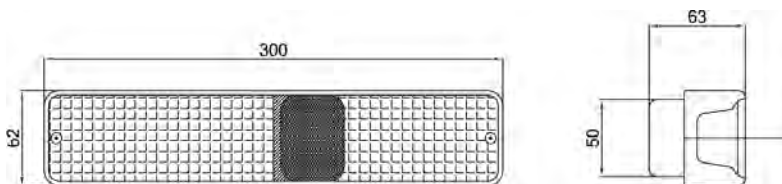
Note:

Lampadine non incluse
 Art. 00441 12V 21W (BA15S) per luce di direzione
 Art. 00440 12V 5/21W (BAY15D) per luce di posizione e stop

Notes:

Bulbs not included
 Pn 00441 12V 21W (BA15S) for direction light
 Pn 00440 12V 5/21W (BAY15D) for position light and stop

Art./Ref.	Lato/Side	Luci/Lights	Fissaggio/Fissaggio	Montaggio/Montaggio	Brand	Rif. Orig./Orig. Ref.	Ricambio/Replacement
27227	Dx-Sx	Luce di posizione, luce di direzione, stop 3.0/Position light, direction light, stop 3.0	Con viti M5/ With M5 screw	296x62mm	A.M.A. - MASSEY FERGUSON	3536200M91	27229 - rodivetro dx-sx x 27227+27228 / rodivetro dx-sx x 27227+27228
27228	Dx-Sx	Luce di posizione, luce di direzione, stop 3.0/Position light, direction light, stop 3.0	Con molle/ With springs	295x60mm	A.M.A.	-	27229 - rodivetro dx-sx x 27227+27228 / rodivetro dx-sx x 27227+27228

FANALE ALOGENO POSTERIORE 184X76MM

FEUX 4 FONCTIONS 184X76MM
 HALOGEN REAR LAMPS 184X76MM
 SCHLUSS-BREMS- BLINKLEUCHTE 184X76MM
 PILOTO TRASERO 4 FUNCIONES 184X76MM

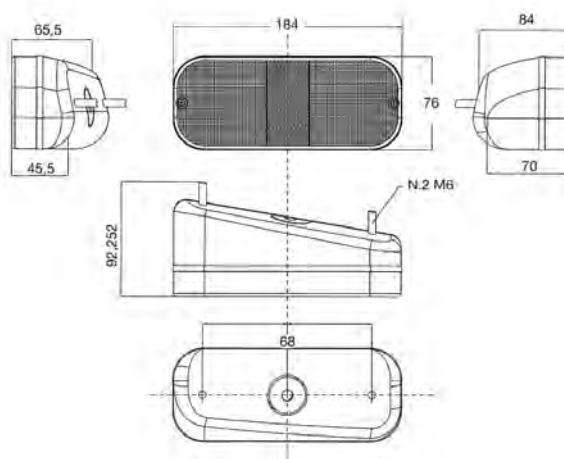
Note:

Interasse 134mm
 Viti M6
 Pre-cablato
 Lampadine non incluse
 Art. 00441 12V 21W (BA15S) per luce di direzione
 Art. 00440 12V 5/21W (BAY15D) per luce di posizione e stop
 Certificazioni: ECE R3 R6 R7

Notes:

Center to center distance 134mm
 M6 screw
 Pre-cable
 Bulbs not included
 Pn. 00441 12V 21W (BA15S) for direction light -
 Pn. 00440 12V 5/21W (BAY15D) for position light and stop
 Certification: ECE R3 R6 R7

Art./Ref.	Lato/Side	Luci/Lights	Brand	Applicazione/Application	Rif. Orig./Orig. Ref.	Ricambio/Replacement
58020	Sx	Luce di posizione, luce di direzione, Stop, catarinfrangente/ Position light, Direction light, stop, reflector	FIAT - A.M.A. - NEW HOLLAND	TD5010, TD5020, TD5030, TD5040, TD5050, TD55D, TD60D, TD65D, TD70D, TD75D, TD80D, TD85D, TD90D, TD95D	5091429, 5091429	58024 - rodivetro per fan 58020-58021 / spare glass for 58020-58021
58021	Dx	Luce di posizione, luce di direzione, Stop, catarinfrangente/ Position light, Direction light, stop, reflector	FIAT - A.M.A. - NEW HOLLAND	TD5010, TD5020, TD5030, TD5040, TD5050, TD55D, TD60D, TD65D, TD70D, TD75D, TD80D, TD85D, TD90D, TD95D	5091434, 5091434	58024 - rodivetro per fan 58020-58021 / spare glass for 58020-58021

FANALE ALOGENO POSTERIORE 350X133MM

FEUX 7 FONCTIONS 350X133MM
 HALOGEN REAR LAMP 350X133MM
 SCHLUSS-BREMS- BLINKLEUCHTE 350X133MM
 PILOTO TRASERO 7 FUNCIONES 350X133MM

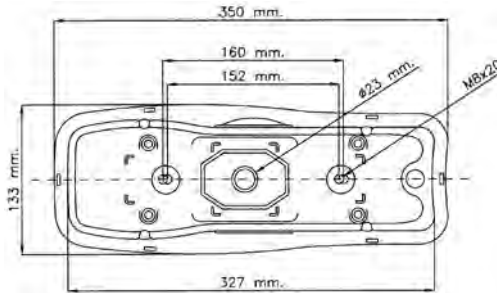

Note:

Interasse 152-160mm
 Connettore a 6 pin
 Art. IME.151 Kit completo connettore e terminali
 Lampadine non incluse: Art. 00441 4 pz 12V 21W (BA15S) per luce di direzione, stop, retromarcia e retronebbia
 Art. 00397 2 pz per luce di posizione

Notes:

Center to center distance 152-160mm
 Pn IME.151 kit connector Bulbs not included
 Pn 00441 4 pcs 12V 21W (BA15S) for direction light, stop, reversing light and fog light
 Pn. 00397 2 pcs for position light

Art./Ref.	Lato/Side	Luci/Lights	Brand	Ricambio/Replacement
59772	Dx /Sx	Luce di posizione, luce di direzione, stop, retromarcia, retronebbia, luce targa, catarinfrangente/ Position light, direction light, stop, reversing light, fog, no plate light, reflector	A.M.A.	59773 - rodivetro per art 59772 / lens to suit 59772

SET 2 FANALI POSTERIORI ALOGENI DX E SX 237X137MM

SET 2 FEU 7 FONCTIONS DROIT & GAUCHE 237X137MM
 SET 2 HALOGEN REAR LAMP RH & LH 237X137MM
 SATZ HALOGEN-RUECKLEUCHTEN RS + LS 237X137MM
 SET 2 PILOTOS TRASERO DCHO & IZDO 7 FUNCIONES 237X137MM

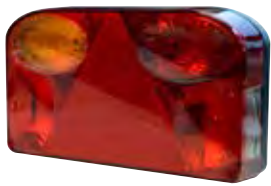

Note:

Interasse di fissaggio: 150mm
 Con connettore e terminali compresi
 Lampadine incluse:
 art. 00441 12V 21W (BA15S)
 art. 00440 12V 5/21W (BAY15D)
 Certificazioni E11

Notes:

Attachment center to center distance: 150mm
 With connector included
 Bulbs included
 Pn 00441 12V 21W (BA15S)
 Pn 00440 12V 5/21W (BAY15D)
 E11 Approval

Art./Ref.	Lato/Side	Luci/Lights
76477	Dx e Sx	Luce di posizione, luce di direzione, stop, retromarcia, retronebbia, luce targa, catarinfrangente triangolare/ Position light, direction light, stop, reversing light, fog, no. plate light, reflector

FANALE POSTERIORE ALOGENO 220X140MM
FEUX 6 FONCTIONS 220X140MM
REAR LAMP 220X140MM
SCHLUSS-BREMS- BLINKLEUCHTE 220X140MM
PILOTO TRASERO 6 FUNCIONES 220X140MM

Note:

Fissaggio con viti M5x20

Lampadine non incluse

Certificato E3

Art. 00440 1 pz: 12V 5/21W (BAY15D) per retromarcia, luce targa, luce di posizione e stop

Art. 00441 3 pz 12V 21W (BA15S) per luce di direzione, retronebbia

Notes:

M5x20 screw fixing

Bulbs not included

E3 approval

Pn. 00440 1 pc: 12V 5/21W (BAY15D) Reversing light, no. plate light, position and stop light

Pn. 00441 3 pcs 12V 21W (BA15S) for direction light, fog light

Art./Ref.	Lato/Side	Luci/Lights	Ricambio/Replacement
59794	Dx	Luce di posizione, Luce di direzione, stop, luce targa, retromarcia, catadiottro triangolare/ Position light, direction light, no. plate light, stop, reversing light, trianglr reflector	59796 - RODOVETRO PER 59794 / RH LENS FOR 59794
59793	Sx	Luce di posizione, Luce di direzione, stop, luce targa, retronebbia, catadiottro triangolare/ Position light, direction light, no. plate light, stop, fog light, trianglr reflector	59795 - RODOVETRO ART 59793 / LH LENS FOR 59793

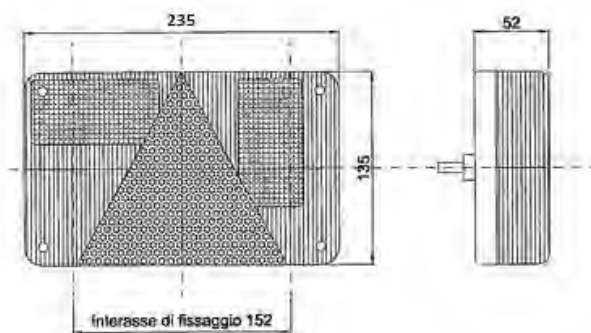
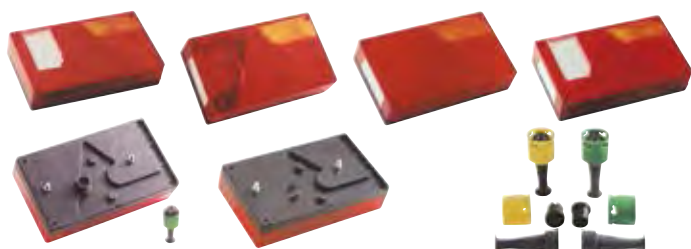
FANALE ALOGENO POSTERIORE 235X135MM
FEUX ARRIERE 235X135MM
HALOGEN REAR LAMP 235X135MM
SCHLUSS-BREMS- BLINKLEUCHTE 235X135MM
PILOTO TRASERO 6 FUNCIONES 235X135MM

Note: Lampadine incluse • Certificati: E3 **Notes:** Bulbs included • E3

Art./Ref.	Lato/Side	Luci/Lights	Montaggio/Montaggio	Ricambio/Replacement
17660	Sx	Luce di posizione, luce di direzione, stop, retronebbia, catarinfrangente triangolare	Art.17673 Presa a innesto rapido	00440 - LAMPADA 12V 5/21W (BAY15D) / 12V S/T BULB 21/5W, 00441 - LAMPADA 12V 21W (BA15S) / 12V S/C FLASHER BULB 21W, 17671 - RODOVETRO X 17660+17664+17668 / LENS FOR 17760+17764+17668
17664	Sx	Luce di posizione, luce di direzione, stop, luce targa, retronebbia e catarinfrangente triangolare/Position light, direction light, stop, no. plate light, rear fog light, reflecto	Art.17673 Presa a innesto rapido	00440 - LAMPADA 12V 5/21W (BAY15D) / 12V S/T BULB 21/5W, 00441 - LAMPADA 12V 21W (BA15S) / 12V S/C FLASHER BULB 21W, 17671 - RODOVETRO X 17660+17664+17668 / LENS FOR 17760+17764+17668,
17679	Sx	Luce di posizione, luce di direzione, stop, luce targa, retronebbia e catarinfrangente triangolare/Position light, direction light, stop, no. plate light, rear fog light, reflector	Con passafilo	00440 - LAMPADA 12V 5/21W (BAY15D) / 12V S/T BULB 21/5W, 00441 - LAMPADA 12V 21W (BA15S) / 12V S/C FLASHER BULB 21W, 17671 - RODOVETRO X 17660+17664+17668 / LENS FOR 17760+17764+17668

Art./Ref.	Lato/Side	Luci/Lights	Montaggio/Montaggio	Ricambio/Replacement
17661	Dx	Luce di posizione, luce di direzione, stop, catarinfrangente triangolare /Position light, direction light, stop, reflector	Art.17674 Presa a innesto rapido	00440 - LAMPADA 12V 5/21W (BAY15D) / 12V S/T BULB 21/5W, 00441 - LAMPADA 12V 21W (BA15S) / 12V S/C FLASHER BULB 21W, 17670 - RODOV.X17661+17663+17665+17667 / LENS FOR17661+1763+17665+17667,17674 - INNESTO RAPIDO DX VERDE X FAN. / NO LONGER AVAILABLE
17666	Dx	Luce di posizione, luce di direzione, stop, luce targa, retromarcia, catarinfrangente triangolare /Position light, direction light, stop, no. plate light, reversing light, reflector	Art.17674 Presa a innesto rapido	00440 - LAMPADA 12V 5/21W (BAY15D) / 12V S/T BULB 21/5W, 00441 - LAMPADA 12V 21W (BA15S) / 12V S/C FLASHER BULB 21W, 17672 - RODOVETRO X 17662+17666+17669 / LENS FOR 17662+17666+17669, 17674 - INNESTO RAPIDO DX VERDE X FAN. / NO LONGER AVAILABLE
17676	Dx	Luce di posizione, luce di direzione, stop, catarinfrangente triangolare /Position light, direction light, stop, reflector	Con passafilo	00440 - LAMPADA 12V 5/21W (BAY15D) / 12V S/T BULB 21/5W, 00441 - LAMPADA 12V 21W (BA15S) / 12V S/C FLASHER BULB 21W, 17670 - RODOV.X17661+17663+17665+17667 / LENS FOR17661+1763+17665+17667
17677	Dx	Luce di posizione, Luce di direzione, stop, retromarcia, catarinfrangente triangolare/Position light, direction light, stop, reversing light, reflector	Con passafilo	00440 - LAMPADA 12V 5/21W (BAY15D) / 12V S/T BULB 21/5W, 00441 - LAMPADA 12V 21W (BA15S) / 12V S/C FLASHER BULB 21W, 17672 - RODOVETRO X 17662+17666+17669 / LENS FOR 17662+17666+17669
17681	Dx	Luce di posizione, luce di direzione, stop, luce targa, retromarcia, catarinfrangente triangolare /Position light, direction light, stop, no. plate light, reversing light, reflector	Con passafilo	00440 - LAMPADA 12V 5/21W (BAY15D) / 12V S/T BULB 21/5W, 00441 - LAMPADA 12V 21W (BA15S) / 12V S/C FLASHER BULB 21W, 17672 - RODOVETRO X 17662+17666+17669 / LENS FOR 17662+17666+17669
17682	Dx	Luce di posizione, luce di direzione, stop, luce targa, retronebbia e catarinfrangente triangolare/Position light, direction light, stop, no. plate light, rear fog light, reflector	Con passafilo	00440 - LAMPADA 12V 5/21W (BAY15D) / 12V S/T BULB 21/5W, 00441 - LAMPADA 12V 21W (BA15S) / 12V S/C FLASHER BULB 21W, 17670 - RODOV.X17661+17663+17665+17667 / LENS FOR17661+1763+17665+17667

1.8.11 Fanali ingombro

Side lights



Ricambi & accessori per macchine agricole

SPARE PARTS & ACCESSORIES FOR AGRICULTURAL MACHINE

Tutti gli articoli della presente sezione, prodotti da AMA SPA e/o da terzi per conto di AMA, sono adattabili ("non originali") alle marche indicate ai sensi di quanto previsto dal REG. CE n. 1400/2002. I diritti sui marchi citati appartengono ai legittimi proprietari ed il loro uso ha l'esclusiva finalità di consentire all'utilizzatore la comparazione dei diversi prodotti. All items of this section, manufactured by AMA SPA and/or any third party on behalf of AMA, are adaptable ("non-original") to the brands listed under the provisions of the REG. CE n. 1400/2002. The rights on the trademarks belong to their respective owners and their usage is only aimed to allow the user to compare different products.

FANALI DI INGOMBRO A LED 12-30V
FEUX DE GABARIT 12-30V
LED MARKING LAMP 12-30V
SEITENMARKIERUNGSLEUCHTE LED 12-30V
LUZ DE POSICION LED 12-30V

Note:

Misure: 130x32mm

Cavo 0,5m 2x0,75mm

4 Led

Connettore rapido a tenuta ermetica QS 150

Notes:

Size: 130x32mm

 Wire: 0,5m 2x0,75mm²

4 Led

Hermetically sealed quick connector QS 150

Art./Ref.	Colore/Color
85461	Bianco/White
85462	Aranzone/Amber
85463	Rosso/Red

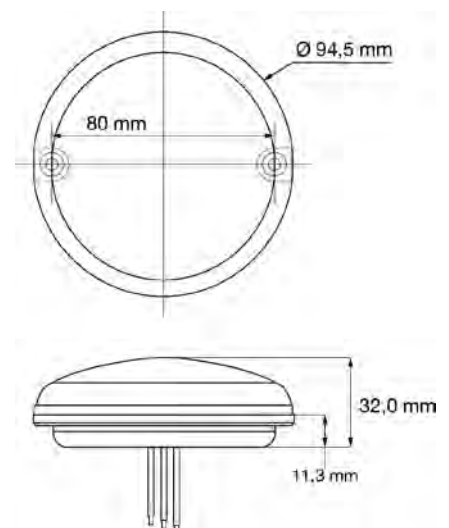
FANALI DI INGOMBRO A LED Ø 95MM
FEUX DE GABARIT Ø 95MM
LED SIDE LIGHTS Ø 95MM
SCHLUSS BEGRENZUNGSLEUCHTE Ø 95MM
PILOTOS Ø 95MM

Note:

Con cablaggio in uscita

Certificazioni E4

IP67

Notes:

With cable

E4 approval

IP67

Art./Ref.	Tipo/Type	Funzioni/Functions	Volt/Volt	LED/LED
84673	Lente rossa/Red len	Posione e stop/Tail and stop lamp	9-33V	15
84675	Lente Ambra /Amber Len	Indicatore di direzione/Indicator lamp	9-33V	15
84676	Lente rossa/Red len	Fanale retronebbia/Fog lamp	9-33V	15
84674	Lente Trasparente /Clear Len	Fanale retromarcia/Reversing lamp	9-33V	15

FANALE RETRONEBBIA E RETROMARCIA A LED Ø 140MM

FEU ARRIERE ANTI-BROUILLARD ET FEU DE REcul LED Ø 140MM
 LED FOG LIGHT & LED REVERSING LIGHT Ø 140MM
 ANBAU-NBELSCHLUSSLEUCHTE LED UND ANBAU-RUCKFAHRSCHEINWRFER LED Ø 140MM
 FARO TRASERO ANUTINIEBLA LED Y FARO DE MARCHA ATRAS LED Ø 140MM

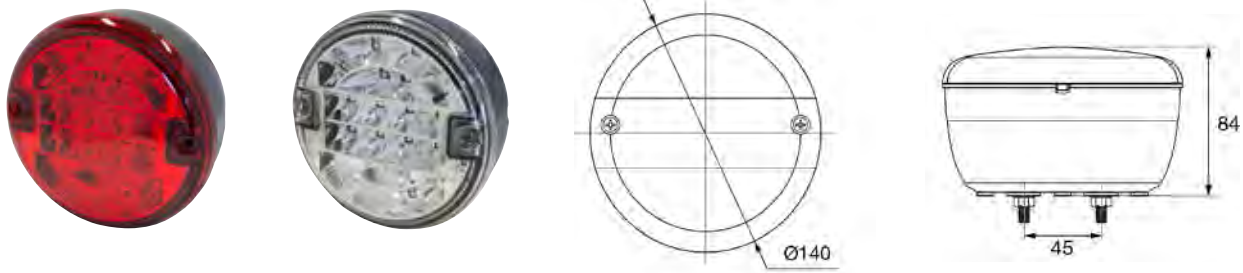

Note: Con cablaggio in uscita
 Certificazioni: E4
 IP67

Notes: With cable
 E4 approval
 IP67

Art./Ref.	Tipo/Type	Funzioni/Functions	Volt/Volt	LED/LED
84671	Lente rossa/Red len	Retronebbia/Fog light	9-34 V	20
84672	Lente Trasparente /Clear Len	Retromarcia/Reversing light	9-34 V	20

FANALE LED RETRONEBBIA 101X81MM

FEUX ANTI-BROUILLARD LED 101X81MM
 LED FOG LIGHT 101X81MM
 NEBELSCHLUSSLEUCHTE LED 101X81MM
 LUZ ANTINIEBLA LED 101X81MM



Note: Interasse 65mm
 Cavi in uscita
 Certificazioni: E4

Notes: Center to center distance 65mm
 With cable
 E4 approval

Art./Ref.	Volt/Volt	Watt/Watt	IP/IP
84499	12V	3W	IP67

FANALE LED RETROMARCIA 101X81MM

FEU DE REcul LED 101X81 MM
 LED REVERSING LIGHT 101X81MM
 RÜCKFAHRLEUCHTE WEIB LED 101X81MM
 LUZ MARCHA ATRAS LED 101X81MM



Note: Interasse 65mm
 Cavi in uscita
 Certificazioni: E4

Notes: Center to center distance 65mm
 With cable
 E4 approval

Art./Ref.	Volt/Volt	Watt/Watt	IP/IP
84498	12V	3W	IP67

FANALI DI POSIZIONE, DIREZIONE, INGOMBRO 54X83MM

FEUX DEGABARIT 54X83MM
 MARKER DIRECTION LAMPS 54X83MM
 BLINKLEUCHTE 54X83MM
 PILOTOS LATERALES 54X83MM



Note: IP55
 Lampadina non inclusa
 Art. 00277 12V 5W C5W
 Certificazioni: ECE

Notes: IP55
 Bulb not included
 Pn 00277 12V 5W C5W
 ECE approval

Art./Ref.	Descrizione/Description	Ricambio/Replacement
27234	Fanale di posizione posteriore (rosso)/Marker direction lamp (red)	27169 - rodovetro rosso x 27234 / red len
27235	Fanale di posizione anteriore (bianco)/Marker direction lamp (White)	27168 - rodovetro bianco x 27235 / white len
27236	Fanale laterale (arancio)/Direction light (amber)	27167 - rodovetro arancio x 27236 / orange len

FANALE RETRONEBBIA E RETROMARCIA 87X77MM

FEU ARRIERE ANTI-BROUILLARD ET FEU DE RECU 87X77MM
 REAR REVERSING AND REAR FOG LIGHT 87X77MM
 ANBAU-NBELSCHLUSSLEUCHTE UND ANBAU-RUCKFAHRSCHEINWRFER 87X77MM
 FARO TRASERO ANUTINEBLA Y FARO DE MARCHA ATRAS 87X77MM

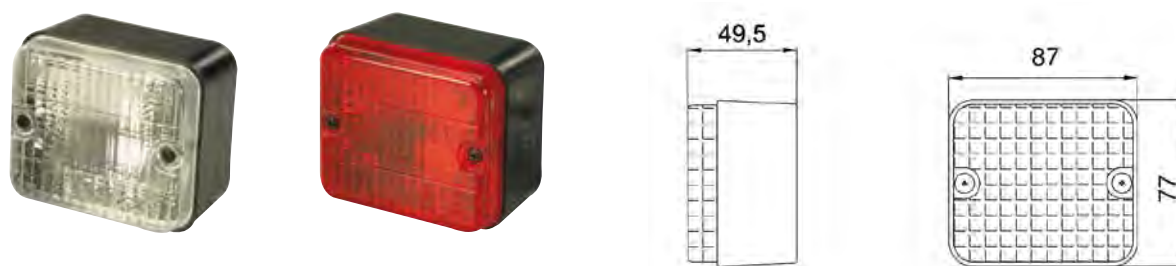

Note: Lampadina non inclusa
 Art. 00441 12V 21W (BA15S)
 Certificazioni: E3

Notes: Bulb not included
 Pn 00441 12V 21W (BA15S)
 E3 approval

Art./Ref.	Colore/Color	Descrizione/Description	Ricambio/Replacement
04356	Rosso/Red	Fanale retronebbia /Fog light	04358 - rodovetro per art. 4356 / lens for art. 4356
04357	Bianco/White	Fanale retromarcia /Rear reversing ight	04359 - rodovetro per art. 4357 / lens for art.4357

LUCE ANTERIORE DI POSIZIONE CON CATARINFRANGENTE

FEU DE POSITION BLANC AVEC CATADIOPTRE
 WHITE POSITION LIGHT WITH REFLECTOR
 BEGRENZUNGLEUCHTE MIT RUCKSTRAHLER
 PILOTO DELANTERO CON CATADIOPTRICO

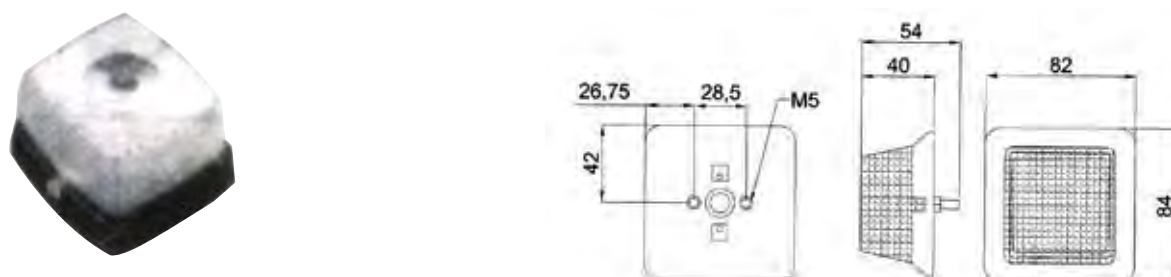

Note: Lampadina non inclusa
 Art. 00277 12V 5W SV8,5
 Certificazioni: CE

Notes: Bulb not included
 Pn 00277 12V 5W SV8,5
 CE Approval

Art./Ref.	Colore/Color
51687	Bianco/White

FANALE D'INGOMBRO 48X84MM

FEU DE GABARAIT LATERAL 48X84MM
 SIDE MARKER LIGHT 48X84MM
 BLINKLEUCHTE 48X84MM
 PILOTO LATERAL 48X84MM



Note: IP54
 Lampadina non inclusa
 Art. 00397 12V 5W R5W (BA15S)
 Certificazioni: ECE

Notes: IP54
 Bulb not included
 Pn 00397 12V 5W R5W (BA15S)
 ECE approval

Art./Ref.	Descrizione/Description	Ricambio/Replacement
27237	Fanale laterale arancio/Amber side marker light	27178 - rodovetro arancio x 27237 /orange len
27176	Fanale d'ingombro bianco e rosso/White and red side marker light	27177 - rodovetro bianco-rosso x 27176 / white-red len

LUCE DI INGOMBRO A LED 12-30V

FEU DE GABARAIT A POSER 12-30V
 12-30V SIDE LED LIGHT
 SCHLUSS-BEGRENZUNGSLEUCHTE LED 12-30V
 LUZ DE GALIBO LED 12-30V

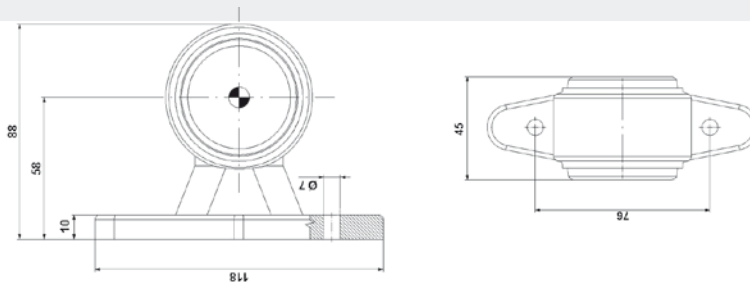

Note: Interasse di fissaggio 78mm
 Cablaggio 2x0,75mm²
 Corpo in gomma

Notes: Center to center distance 78mm
 2x0,75mm² cable
 Rubber bracket

Art./Ref.	Descrizione/Description	Colore/Color
75433	2 Led	rosso e bianco/red and white

LUCE DI INGOMBRO A LED 12-30V

FEU DE GABARIT LED INCLINES 12-30V
 12-30V SIDE LED LIGHT
 SCHLUSS-BEGRENZUNGSLEUCHTE LED 12-30V
 BRAZO DE GALIBO LED RECTO 12-30V



Note: Interasse di fissaggio 78mm
 Cablaggio 2x0,75mm²
 Corpo in gomma

Notes: Center to center distance 78mm
 2x0,75mm² cable
 Rubber bracket

Art./Ref.	Descrizione/Description	Colore/Color
75434	2 Led	rosso e bianco/red and white

LUCE DI INGOMBRO A LED 12-30V
FEU DE GABARIT LED COUDES 12-30V
12-30V SIDE LED LIGHT
SCHLUSS-BEGRENZUNGSLEUCHTE LED 12-30V
BRAZO DE GALIBO LED CURVO 12-30V

Note: Interasse di fissaggio 78mm
Cablaggio 2x0,75mm²
Corpo in gomma

Notes: Center to center distance 78mm
2x0,75mm² cable
Rubber bracket



Art./Ref.	Descrizione/Description	Colore/Color
75435	2 Led	rosso e bianco/red and white

LUCE DI INGOMBRO 97X90MM
FEU DE GABARIT 97X90MM
SIDE LIGHT 97X90MM
SCHLUSS-BEGRENZUNGSLEUCHTE 97X90MM
LUZ DE GALIBO 97X90MM

Note: Cavo per 2x0,75mm²
Interasse di fissaggio 77mm
Staffa in gomma con rinforzo in metallo
Lampadina non inclusa
art. 00397 12V 5W (BA15S)
art. 00524 24V 5W (BA15S)
Certificazioni: E9

Notes: 2x0,75mm² cable with 6/3 joints
Center to center distance 77mm
Rubber bracket with sheetmetal reinforced
Bulb not included
Pn. 00397 12V 5W (BA15S)
Pn. 00524 24V 5W (BA15S)
E9 Approval



Art./Ref.	Colore/Color	Ricambio/Replacement
00745	Bianco e rosso/White-Red	00738 - rodivetro rosso per luci ing. / red lense to suit 00745,00739 - rodivetro bianco per luci ing. / white lense to suit 00745

LUCE DI INGOMBRO 97X175MM
FEU DE GABARIT 97X175MM
SIDE LIGHT 97X175MM
SCHLUSS-BEGRENZUNGSLEUCHTE 97X175MM
BRAZO DE GALIBO CURVO 97X175MM

Note: Cavo per 2x0,75mm²
Interasse di fissaggio 77mm
Staffa in gomma con rinforzo in metallo
Lampadina non inclusa
art. 00397 12V 5W (BA15S)
art. 00524 24V 5W (BA15S)
Certificazioni: E9

Notes: 2x0,75mm² cable with 6/3 joints
Center to center distance 77mm
Rubber bracket with sheetmetal reinforced
Bulb not included
Pn. 00397 12V 5W (BA15S)
Pn. 00524 24V 5W (BA15S)
E9 Approval



Art./Ref.	Colore/Color	Ricambio/Replacement
00746	Bianco e rosso/White/Red	00738 - rodivetro rosso per luci ing. / red lense to suit 00745,00739 - rodivetro bianco per luci ing. / white lense to suit 00745

3LUCE TARGA A LED

ECLAIREUR DE PLAQUE LED
NUMBER PLATE LED LIGHT
KENNZEICHENLEUCHTE LED
LUZ DE MATRICULA LED

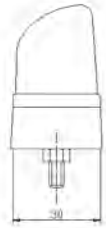
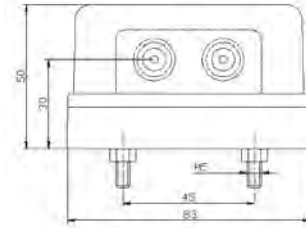
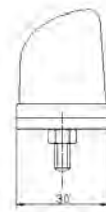
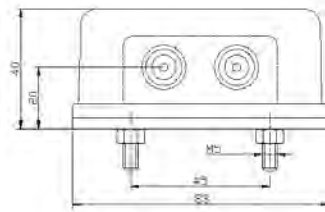

Art./Ref.	Posizione/Position	Descrizione/Description	Dimensioni/Sizes	Note/Note
81218	12V	2 led	84x30,5x33,5 mm	lunghezza cablaggio 0,2 m/cable 0,2 m
81219	10-30V	2 led	83x30,5x40 mm	Lunghezza cablaggio 0,5 m/Cable 0,5 m

FANALE TARGA

ECLAIREUR DE PLAQUE
NUMBER PLATE LIGHTS
KENNZEICHENLEUCHTE
LUZ DE MATRICULA



Note: Lampadina non inclusa
art. 00277 12V 5W CSW SV8.5-8

Notes: Bulb not included
Pn 00277 12V 5W CSW SV8.5-8

Art./Ref.	Dimensioni/Sizes	Descrizione/Description	Note/Note	Posizione/Position
00405	83 x 33 mm	Fissaggio: 2 viti M6x20 interasse 45mm/ 2 Screw M6x20, Center to center distance 45mm	Certificazioni: E3/E3 approval	Universale
15861	80 x 31 mm	Fissaggio 2 viti M6 Interasse 45mm/ 2 Screw M6 Cenetr to center distance 45mm	Certificazioni: E1 12815/E1 12815 approval	HELLA 2KA 001 389-107
26166	237x109 mm	Fissaggio 2 viti M5/2 Screw M5	Certificazioni: ECE/ECE Approval	COBO 02.246.000

FANALE LATERALE 108X57MM

FEU DE GABARIT LATERAL 108X57MM
SIDE MARKER LIGHT 108X57MM
BLINKLEUCHTE 108X57MM
PILOTO LATERAL 108X57MM

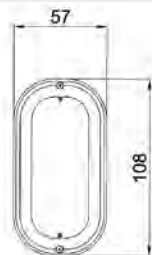

Note: Interasse di fissaggio 93mm
Lampadina non inclusa
Art. 00397 12V 5W (BA15S)
Certificazioni: ECE

Notes: Center to center distance: 93mm
Bulb not included
Pn 00397 12V 5W (BA15S)
CEE approval

Art./Ref.
00412

FANALE LATERALE 82X29MM

FEU DE GABARAIT LATERAL 82X29MM
SIDE MARKER LIGHT 82X29MM
BLINKLEUCHTE 82X29MM
PILOTO LATERAL 82X29MM

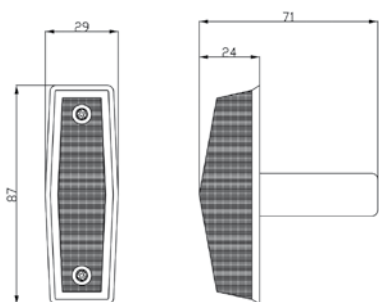

Note: Lampadina non inclusa
art. 00451 12V 3W (BA9S) T4W
Certificazioni: ECE

Notes: Bulb not included
Pn 00451 12V 3W (BA9S) T4W
ECE approval

Art./Ref.	Ricambio/Replacement
00461	00451 - lampada 12v 3w spia (ba9s) / bulb 12v 3w dash bulb

FANALE LATERALE 42X39MM

FEU DE GABARAIT LATERAL 42X39MM
SIDE MARKER LIGHT 42X39MM
BLINKLEUCHTE 42X39MM
PILOTO LATERAL 42X39MM

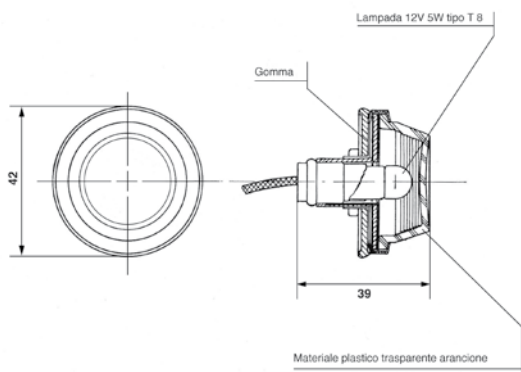

Note: Lampadina non inclusa
art. 00451 12V 3W (BA9S) T4W
Certificazioni: ECE

Notes: Bulb not included
Pn 00451 12V 3W (BA9S) T4W
ECE approval

Art./Ref.
00696

FANALE LATERALE ARANCIO 88,5X24,5MM

FEU DE GABARAIT LATERAL 88,5X24,5MM
SIDE MARKER LIGHT 88,5X24,5MM
BLINKLEUCHTE 88,5X24,5MM
PILOTO LATERAL 88,5X24,5MM

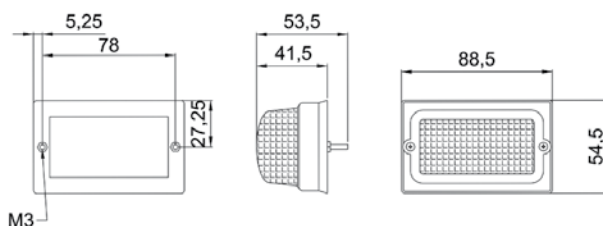

Note: Viti M3
Interasse 78mm
Lampadina non inclusa:
Art. 00277 12V 5W 10,5X38
Certificazione: ECE

Notes: M3 Screw
Distance center to center 78mm
Bulbs not included
PN 00277 12V 5W 10,5X38
ECE Approval

Art./Ref.	Ricambio/Replacement
02867	02868 - rodovetro per fanale art.2867 / glass for lamp

FANALE FRECCIA 89X55MM

FEU CLIGNOTANT 89X55MM
DIRECTION LIGHT 89X55MM
BLINKLEUCHTE 89X55MM
INTERMITENTE 89X55MM



Note: Lampadina non inclusa
art. 00441 12V 21W (BA15S)
Certificazioni: ECE

Notes: Bulb not included
Pn 00441 12V 21W (BA15S)
ECE approval

Art./Ref.	Lato/Side	Ricambio/Replacement
05538	Dx	05585 - rodovetro dx per fanalino 5538 / lens for lamp 05538
05539	Sx	05586 - rodovetro sx per fanalino 5539 / lens for lamp 05539

1.8.12 Lampadine

Bulbs



Ricambi & accessori per macchine agricole

SPARE PARTS & ACCESSORIES FOR AGRICULTURAL MACHINE

Tutti gli articoli della presente sezione, prodotti da AMA SPA e/o da terzi per conto di AMA, sono adattabili ("non originali") alle marche indicate ai sensi di quanto previsto dal REG. CE n. 1400/2002. I diritti sui marchi citati appartengono ai legittimi proprietari ed il loro uso ha l'esclusiva finalità di consentire all'utilizzatore la comparazione dei diversi prodotti. All items of this section, manufactured by AMA SPA and/or any third party on behalf of AMA, are adaptable ("non-original") to the brands listed under the provisions of the REG. CE n. 1400/2002. The rights on the trademarks belong to their respective owners and their usage is only aimed to allow the user to compare different products.

















LAMPADINE PER VEICOLI OSRAM





LAMPES POUR VEHICULES

LAMPS FOR VEHICLES

LAMPE FÜR FAHRZEUGE

LAMPARAS PARA VEHICULOS

Art./Ref.	ECE/ECE	Volt/Volt	Watt/Watt	Attacco/Connection	Blister/Packaging	Immagine/Image
34505	P21W	12	21	BA15s	-	
34507	P21/5W	12	21/5	BAY15d	-	
34508	R5W	12	5	BA15s	-	
34509	R10W	12	10	BA15s	-	
34510	-	12	3	BA9s	-	
34511	W3W	12	3	W2,1x9,5d	-	
34514	C5W	12	5	SV8,5-8	-	
34517	H3	12	55	P43t	-	
34518	H4	12	60/55	P43t	-	
34516	H1	12	55	P14,5s	-	
34536	H7	12	55	PX26d	-	
34523	R5W	24	5	BA15s	-	
34528	H3	24	70	PK22s	-	
38904	H1	12	55	P14,5s	1 Pz.	
38905	H3	12	55	P43t	1 Pz.	
38906	-	12	60/55	P43t	1 Pz.	
38907	H7	12	55	PX26d	1 Pz.	

Art./Ref.	ECE/ECE	Volt/Volt	Watt/Watt	Attacco/Connection	Blister/Packaging	Immagine/Image
38908	P21W	12	21	BA15s	2 Pz.	
38909	P21/5W	12	21/5	BAY15d	2 Pz.	
38910	R5W	12	5	BA15s	2 Pz.	
38911	R10W	12	10	BA15s	2 Pz.	
38912	W3W	12	3	W2,1x9,5d	2 Pz.	
38913	C5W	12	5	SV8.5-8	2 Pz.	

LAMPADE PER VEICOLI OSRAM



LAMPES POUR VEHICULES

LAMPS FOR VEHICLES

















LAMPE FÜR FAHRZEUGE

LAMPARAS PARA VEHICULOS









Art./Ref.	Volt/Volt	Watt/Watt	ECE/ECE	Attacco/Connection	Blister/Packaging	Immagine/Image
85454	H1	12	55	P14.5s	Box 2 pz	
85455	H4	12	60/55	P43t	Box 2 pz	
85456	H7	12	55	PX26d	Box 2 pz	

LAMPADE AUTOMOTIVE
LAMPES POUR VEHICULES
LAMPS FOR VEHICLES
LAMPE FÜR FAHRZEUGE
LAMPARAS PARA VEHICULOS

Art./Ref.	Volt/Volt	Watt/Watt	ECE/ECE	Attacco/Connection	Blister/Packaging	Immagine/Image
L26049	12	1	-	Faston maschio 6,3x0,8mm	-	
00451	12	3	-	BA9s	-	
00451C	12	3	-	BA9s	2 pz	
00398	12	3	W3W	W2,1X9,5d	-	
00397	12	5	R5W	BA15s	-	
00397C	12	5	R5W	BA15s	2 pz	
00277	12	5	C5W	SV8,5-8	-	
00277C	12	5	C5W	SV8,5-8	2 pz	
03874	12	10	R10W	BA15s	-	
03874C	12	10	R10W	BA15s	2 pz	
12581	12	10	C10W	SV8,5-8	-	
58129	12	20	-	G4	-	
00441	12	21	P21W	BA15s	-	
00440	12	21/5	P21/5W	BAY15d	-	
00440C	12	21/5	P321/5W	BAY15d	2 pz	
00295	12	45/40	R2	P45t	-	

Art./Ref.	Volt/Volt	Watt/Watt	ECE/ECE	Attacco/Connection	Blister/Packaging	Immagine/Image
00295C	12	45/40	R2	P45t	1 pz	
00439	12	45/40	S2	BA20d		
00439C	12	45/40	S2	BA20d	1 pz	
00278	12	50	-	BA20s	-	
L26065	12	50	-	GE886	-	
00299	12	55	H3	P43t	-	
00299C	12	55	H3	P43t	1 pz	
08048	12	55	H1	P14,5s	-	
08048C	12	55	H1	P14,5S	1 pz	
00373	12	60/55	H4	P43t	-	
12629	12	60/55	H5 H4	P45t	-	
L26050	24	1	-	Faston maschio 6,3x0,8mm	-	
00525	24	3	-	BA9s	-	
00524	24	5	R5W	BA15s	-	
00526	24	5	C5W	SV8,5-8	-	
04019	24	21	P21W	BA15s	-	
00501	24	21/5	P21/5W	BAY15d	-	

Art./Ref.	Volt/Volt	Watt/Watt	ECE/ECE	Attacco/Connection	Blister/Packaging	Immagine/Image
00409	24	50	-	BA20s	-	
00391	24	50/45	R2	BA20d	-	
L26012	24	55	R2	P45t	-	
08049	24	70	H1	P14,5s	-	
00446	24	70	H3	PK22s	-	
00446C	24	70	H3	PK22s	1 Pz.	
00375	24	70/75	H4	P43t	-	

1.8.13 Accessori cablaggio elettrico

Electric wiring spare parts and accessories



Ricambi & accessori per macchine agricole SPARE PARTS & ACCESSORIES FOR AGRICULTURAL MACHINE

Tutti gli articoli della presente sezione, prodotti da AMA SPA e/o da terzi per conto di AMA, sono adattabili ("non originali") alle marche indicate ai sensi di quanto previsto dal REG. CE n. 1400/2002. I diritti sui marchi citati appartengono ai legittimi proprietari ed il loro uso ha l'esclusiva finalità di consentire all'utilizzatore la comparazione dei diversi prodotti. All items of this section, manufactured by AMA SPA and/or any third party on behalf of AMA, are adaptable ("non-original") to the brands listed under the provisions of the REG. CE n. 1400/2002. The rights on the trademarks belong to their respective owners and their usage is only aimed to allow the user to compare different products.

FUSIBILI A LAMELLA

FUSIBLES A LAMELLE
CONTINENTAL FUSES
SCHMELZSICHERUNGEN
FUSIBLES



Art./Ref.	Ampere/AMP	Colore/Color
11910	5	Giallo/Yellow
02358	8	Nero/Black
11911	10	Bianco/White
01381	16	Verde/Green
02397	25	Marrone/Brown
01694	40	Rosso/Red

ASSORTIMENTO FUSIBILI A LAMELLA 75 PZ

COFFRET 75 FUSIBLES A LAMELLE
75 PCS CONTINENTAL FUSES ASSORTMENT
SICHERUNGSSORTIMENT 75 STK
ASSORTIMENTO FUSIBILI A LAMELLA 75 PZ



Note: Portafusibili incluso

Notes: Portafusibili incluso

Art./Ref.	Descrizione estesa/ Descrizione estesa	Note/Note
85429	assortimento fusibili a siluro 75 pezzi da 2A a 25A più portafusibili.	Assortimento: 2A 10 pz, 5A 15 pz, 8A 20 pz, 16A 15 pz, 25A 15 pz e portafusibile 3 pz. Assortment: 2A 10 pcs, 5A 15 pcs, 8A 20 pcs, 16A 15 pcs, 25A 15 pcs and fuse holder 3 pcs.

FUSIBILI BILAMA 19X20MM

FUSIBLES ENFICHABLES
BLADE FUSES
FLACHSTECKSICHERUNGEN
FUSIBLES CON DOS HOJAS

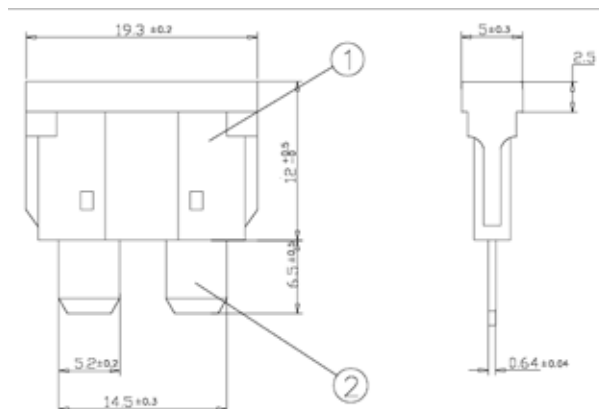

Note: FIAT 9.91815 - DIN 72581 - SAE J 1284

Notes: FIAT 9.91815 - DIN 72581 - SAE J 1284

Art./Ref.	Ampere/AMP	Colore/Color	Blister/Packaging
F17181	1	Nero/Black	-
F17089	2	Grigio/Grey	-
F17002	3	Viola/Vaiiolet	-
F17003	4	Rosa/Pink	-
F17004	5	Beige/Beige	-
03879	7,5	Marrone/Brown	-
03879C	7,5	Marrone/Brown	10 Pz.
03875	10	Rosso/Red	-
03875C	10	Rosso/Red	10 Pz.
03876	15	Blu/Blue	-
03876C	15	Blu/Blue	10 Pz.
03884	20	Giallo/Yellow	-
03884C	20	Giallo/Yellow	10 Pz.
03880	25	Bianco/White	-
03880C	25	Bianco/White	10 Pz.
03885	30	Verde/Green	-

ASSORTIMENTO FUSIBILI BILAMA 97 PZ

COFFRET 97 FUSIBLES ENFICHABLES
 BLADE FUSES ASSORTMENT 97 PZ
 SCHACHTEL 97 STK FLACHSTECKSICHERUNGEN
 FUSE SURTIDO 97 PZ



Art./Ref.	Descrizione estesa/ Descrizione estesa	Note/Note
85428	assortimento fusibili 96 pezzi da 3A a 30A più estrattore.	Assortimento: 3A 12 pz, 5A 12 pz, 7.5A 12 pz, 10A 12 pz, 15A 12 pz, 20A 12 pz, 25A 12 pz, 30A 12 pz e estrattore 1 pz Assortment: 3A 12 pcs, 5A 12 pcs, 7.5A 12 pcs, 10A 12 pcs, 15A 12 pcs, 20A 12 pcs, 25A 12 pcs, 30A 12 pcs and fuse puller 1 pcs

BLISTER 10 PZ FUSIBILI BILAMA

CARTES BLISTER 10 PCS FUSIBLES ENFICHABLES
 BLISTER CARD 10 PCS BLADE FUSES
 BLISTER 10 SK FLACHSTECKSICHERUNGEN
 BLISTER 10 PZ FUSIBLES



Art./Ref.	Note/Note
75748	Art. F17002 3A 1 pz, Art. F17004 5A 1 pz, Art. 03879 7,5A 1 pz, Art. 03875 10A 2 pz Art. 03876 15A 1 pz Art. 03884 20A 2 pz Art. 03880 25A 1 pz Art. 03885 30A 1 pz

BLISTER 10 FUSIBILI BILAMA 19X20MM

BLISTER DE 10 FUSIBLES ENFICHABLES 19X20MM
 10 PCS BLISTER BLADE FUSES 19X20MM
 BLISTER FLACHSTECKSICHERUNGEN MIDI 10 STK 19X20MM
 BLISTER 10 PZ FUSIBLES CON DOS HOJAS 19X20MM



Art./Ref.	Note/Note
1001828	Art. F17004 5A 1 pz, Art. 03879 7,5A 1 pz, Art. 03875 10A 2 pz, Art. 03876 15A 2 pz, Art. 03884 20A 2 pz, Art. 03880 25A 1 pz, Art. 03885 30A 1 pz

MINI FUSIBILI BILAMA

MINIFUSIBLES
 MINI FUSE
 MINI FLACHSTECKSICHERUNGEN
 MINI FUSIBLE



Note: SAE J 2077
 Notes: SAE J 2077

Art./Ref.	Ampere/AMP	Colore/Color
F17169	2	Grigio/Grey
F17170	3	Viola/Violet
58599	5	Beige/Beige
58600	7,5	Marrone/Brown
58601	10	Rosso/Red
58602	15	Blu/Blue
58603	20	Giallo/Yellow
58604	25	Naturale/Natural
58605	30	Verde/Green

BLISTER 10 MINI FUSIBILI BILAMA 11X15MM

BLISTER DE 10 FUSIBLES MINI ENFICHABLES 11X15MM
 10 PCS BLISTER MINI BLADE FUSES 11X15MM
 BLISTER FLACHSTECKSICHERUNGEN 10STK 11X15MM
 BLISTER 10 PZ FUSIBLES CON DOS HOJAS 11X15MM



Art./Ref.	Note/Note
1001827	Art. 58599 5A 1 pz, Art. 58560 7,5A 1 pz, Art. 58601 10A 2 pz, Art. 58602 15A 2 pz, Art. 58603 20A 2 pz, Art. 58604 25A 1 pz, Art. 58605 30A 1 pz

MAXI FUSIBILI BILAMA

FUSIBLES ENFICHABLES MAXI
 MAXI BLADE FUSES
 MAXI FLACHSTECKSICHERUNGEN
 MAXI FUSIBLES

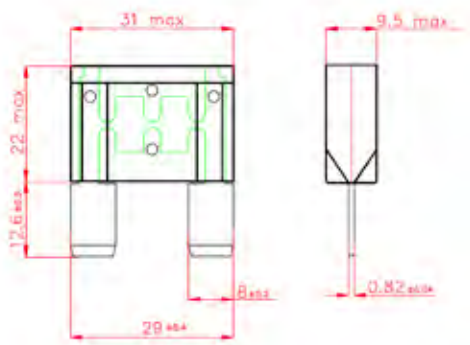

Note: Art. F17187: portafusibile maxi 1 via
Notes: Pn F17187: 1way maxi fuse box

Art./Ref.	Ampere/AMP	Colore/Color
59809	20	Giallo/Yellow
59810	30	Verde/Green
59811	40	Arancio/Orange
59812	50	Rosso/Red
59813	60	Blu/Blue
59814	70	Naturale/Natural
59815	80	Beige/Beige
59816	100	Viola/Vaiiolet

BLISTER 2 PZ FUSIBILI MAXI 29X34MM

2 PC CARTES BLISTER FUSIBLES MAXI ENFICHABLES 29X34MM
 2 PCS BLISTER CARD MAXI BLADE FUSES 29X34MM
 BLISTER 2STK MAXI STECKSICHERUNGEN 29X34MM
 BLISTER 2PZ FUSIBLES CON DOS HOJAS 29X34MM



Art./Ref.	Note/Note
75749	Art. 59812 50A 1 pz, Art. 59813 60A 1 pz

ART. 00263 CONFEZIONE FUSIBILI A LAMELLA E BILAMA ASSORTITI 600 PZ

CONFECTION EN BOITE 600PCS FUSIBLES A LAMELLE ET FUSIBLES ENFICHABLES
 BOX WITH 600 CONTINENTAL FUSES AND BLADE FUSE
 SCHACHTEL 600 STK SCHMELZSICHERUNGEN UND FLACHSTECKSICHERUNGEN
 SURTIDO FUSIBLES CON ESPOSITOR



Art./Ref.	Tipo/Type	Ampere/AMP	Colore/Color	Note/Note
02358	Lamella	8	Nero/Black	150 pz
01381	Lamella	16	Verde/Green	150 pz
01694	Lamella	40	Rosso/Red	100 pz
03879	Bilama	7,5	Marrone/Brown	50 pz
03875	Bilama	10	Rosso/Red	50 pz
03876	Bilama	15	Blu/Blue	50 pz
03880	Bilama	25	Bianco/White	50 pz

FUSIBILI A NASTRO

FUSIBLES À RUBAN
 STRIP FUSES
 STREIFENSICHERUNG
 FUSIBLES A CINTA



Art./Ref.	Ampere/AMP
F17018	30
F17019	40
F17020	50
F17021	60
F17022	80
F17023	100

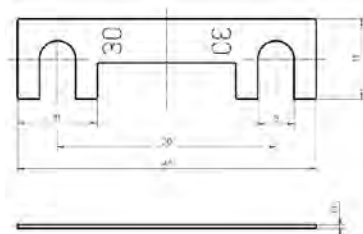

FUSIBILI TIPO MEGA

FUSIBLES TYPE MEGA
 FUSES TYPE MEGA
 SICHERUNGEN TYP MEGA
 FUSIBLES TIPO MEGA

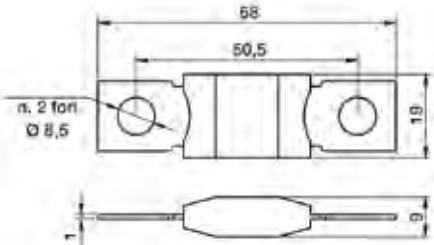

Art./Ref.	Ampere/AMP
F17105	100
F17106	125
F17107	150
F17109	175
F17110	200
F17112	250
F17153	300

PORTAFUSIBILE A TENUTA STAGNA

PORTE FUSIBLE ETANCHE
 WATERPROOF FUSE HOLDER
 WASSERDICHTER SICHERUNGSHALTER
 PORTAFUSIBILES ESTANCOS



Art./Ref.	Tipo/Type	Note/Note
58608	Per mini fusibili/For mini blade fuses	Cavo 4 mm ² x 120mm
58609	Per fusibile bilama/For fuse holder	Cavo 4 mm ² x 120mm

TERMINALE ISOLATO TERMORETRAIBILE

COSES BOUT-A-BOUT THERMORETRACTABLES
 INSULATED TERMINAL HEAT SHRINK
 SCHRUMPF LOTVERBINDER
 TERMINAL TUBO TERMO RETRACTIBLE



Art./Ref.	Sezione/Section	Colore/Color
58611	0,75- 1,25 mm ²	Rosso/Red
58612	1,25 - 2,5 mm ²	Blu/Blue
58613	2,5 - 6 mm ²	Giallo/Yellow

SCATOLA PORTAFUSIBILI A 8 VIE

BOITE A 6 FUSIBLES STANDARD, COSSES LATERAL
 6 WAYS FUSE BOXES LATERLA EXITS
 SICHERUNGSDOSE 6-POLIG
 CAJA PORTAFUSIBLES CON 8 VIAS



Art./Ref.	Modello/Model	Tipo/Type	Note/Note
03883	8 Vie	Per fusibile bilama/ For fuse holder	Con coperchio/ With cover

PORTAFUSIBILE PREDISPOSTO PER 6 FUSIBILI A SILURO

PORTE FUSIBLES
 FUSE BOX FOR 6 DUSES
 SICHERUNGSKASTEN FÜR 6 SICHERUNGEN
 PORTAFUSIBILE



Art./Ref.	Note/Note	Brand	Rif. Orig./Orig. Ref.
15563	Complete di coperchio. Montano esclusivamente fusibili a siluro. With cap. Only for torpedo fuses.	FIAT	4176846, 4216867, 5118445, 5118446

PORTAFUSIBILE 1 VIA PER FUSIBILI A NASTRO

PORTE-FUSIBLES 1 VOIE POUR FUSIBLES A RUBAN
 1 WAY FUSE HOLDER FOR STRIP FUSES
 1 POLIG SICHERUNGSHALTER FUR STREIFENSICHERUNGEN
 PORTAFUSIBLES

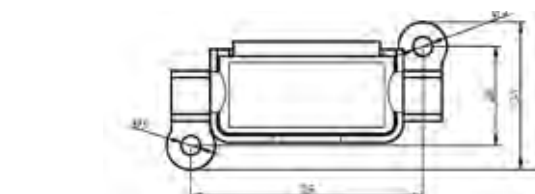
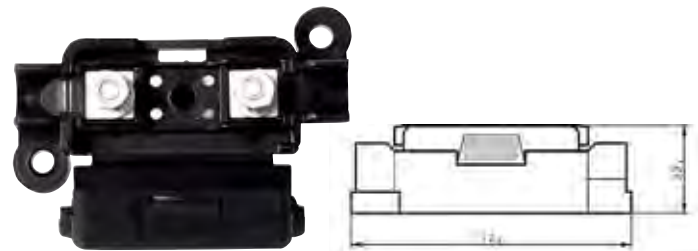

Art./Ref.	Modello/Model
F17025	1 via

PORTAFUSIBILE 1 VIA PER MAXI FUSIBILI BILAMA

PORTE-FUSIBLE 1 VOIE POUR FUSIBLES ENFICHABLES MAXI
 1 WAY FUSE HOLDER FOR MAXI BLADE FUSES
 1 POLIG SICHERUNGSDOSE FÜR MAXI FLACHSTECKSICHERUNGEN
 PORTAFUSIBLES

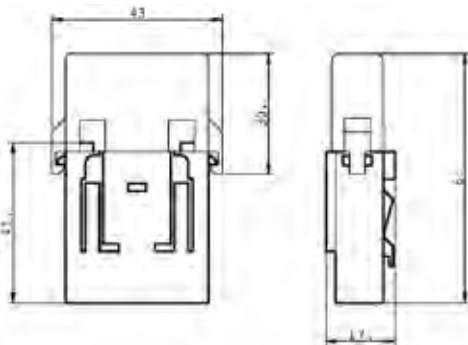

Note: Art. F22096.S staffa

Notes: Pn F22096.1 fixing plate

Art./Ref.	Modello/Model	Note/Note
F17187	1 via	Con coperchio e terminali/ With cover and terminal

PORTAFUSIBILI 1 VIA PER FUSIBILI TIPO MEGA

PORTE FUSIBLE POUR FUSIBLES MEGA
 1 WAY FUSE HOLDER FOR MEGA FUSES
 SICHERUNGSHALTER FÜR MEGASICHERUNGEN
 PORTAFUSIBLES

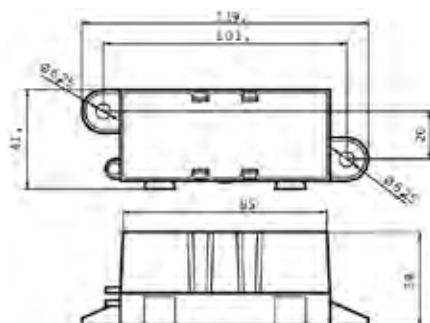

Art./Ref.	Modello/Model	Note/Note
F17113	1 via	Con coperchio/With cover

PORTAFUSIBILE 1 VIA PER FUSIBILI A LAMELLA

PORTA-FUSIBLE POUR FUSIBLES A LAMELLE
 1 WAY FUSE HOLDER FOR CONTINENTAL FUSES
 1 POLIG SICHERUNGSHALTER FÜR SCHMELZSICHERUNGEN
 PORTAFUSIBLES A LEGUITA



Note: Art. 02358 Fusibili a lamella 8A incluso

Notes: Pn 02358 8A continental fuse included

Art./Ref.	Modello/Model	Note/Note	Brand	Rif. Orig./Orig. Ref.
02842	1 via	Attacco a faston	FIAT	5112515

PORTAFUSIBILE 1 VIA PER FUSIBILI A LAMELLA

PORTA-FUSIBLE POUR FUSIBLES A LAMELLE
 1 WAY FUSE HOLDER FOR CONTINENTAL FUSES
 1 POLIG SICHERUNGSHALTER FÜR SCHMELZSICHERUNGEN
 PORTAFUSIBLES A BAYONETA



Note: Art. 02358 Fusibili a lamella 8A incluso

Notes: Pn 02358 8A continental fuse included

Art./Ref.	Modello/Model	Note/Note
01372	1 via	Con viti

PORTAFUSIBILE COMPONIBILE PER FUSIBILI BILAMA

PORTE FUSIBLE COMPOSABLE POUR FUSIBLES ENFICHABLES
 MODULAR FUSE HOLDER FOR BLADE FUSES
 STECKBARER SICHERUNGSHALTER/SICHERUNGSHALTER FÜR STANDARD STECKSICHERUNGEN
 PORTAFUSIBLE COMPONIBLE

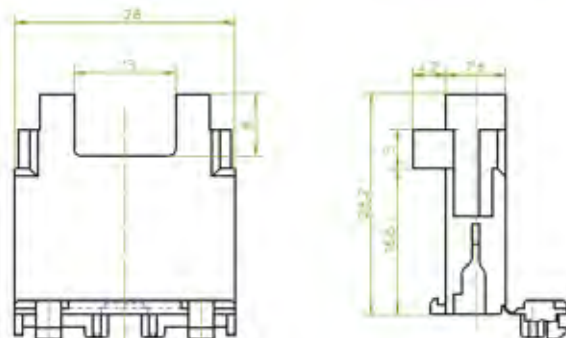

Art./Ref.	Tipo/Type
11912	Corpo portafusibile/In line fuseholder without terminals
11913	Coperchio di protezione /Cover
11914	Terminale da agganciare per cavo 0,5÷1,5 mm ² / Clip on terminal for cable 0,5÷1,5 mm ²

SCATOLE PORTAFUSIBILI PER FUSIBILI BILAMA

PORTE FUSIBLES POUR FUSIBLES ENFICHABLES

FUSE HOLDER FOR BLADE FUSES

SICHERUNGSHALTER FÜR STD STECKSICHERUNGEN

CAJAS PORTAFUSIBLES



Note: Completi di coperchio e viti di fissaggio UNI5923 M4X30

Notes: Cover and screw UNI5923 M4X30 included

Art./Ref.	N° Poli/N° Poli
03881	6 vie
03882	12 vie

TERMINALI

COSES

TERMINALS

RINGZUNGENENDVERSCHLUSSEN

EXTREMIDADES DEL CABLE

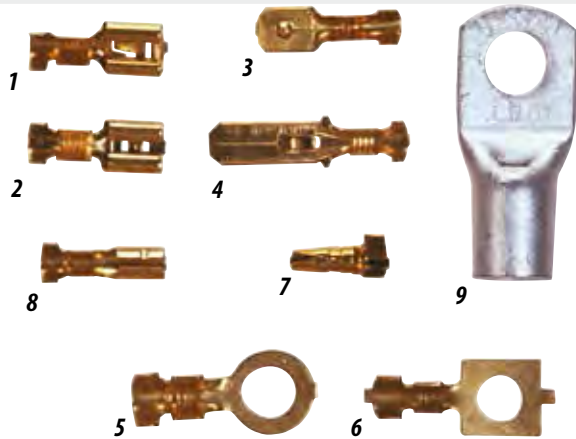

Art./Ref.	Pos.	Modello/Model	Tipo/Type	Sezione/Section	Note/Note	Blister/Packaging
01880	2	Terminale	Femmina/Female	0,5 ÷ 1,5mm ²	Ottone/Brass	-
01880C	2	Terminale	Femmina/Female	0,5 ÷ 1,5mm ²	Ottone/Brass	10 pz
02582	1	Terminale per connettori multipli	Femmina/Female	1,0 ÷ 2,5mm ²	Ottone/Brass	-
02582C	1	Terminale per connettori multipli	Femmina/Female	1,0 ÷ 2,5mm ²	Ottone/Brass	10 pz
01881	3	Terminale	Maschio/Male	1,0 ÷ 2,5mm ²	Ottone/Brass	-
02583	4	Terminale	Maschio/Male	0,75 ÷ 2,0mm ²	Ottone/Brass	-
02583C	4	Terminale	Maschio/Male	0,75 ÷ 2,0mm ²	Ottone/Brass	10 pz
02588	5	Terminale ad occhiello	Foro ø 6 mm/Hole ø 6	3,0 ÷ 6,0mm ²	Ottone/Brass	-
02589	6	Terminale ad occhiello quadrato	Foro ø 6 mm/Hole ø 6 mm	1,0 ÷ 2,5mm ²	Ottone/Brass	-
01882	7	Terminali con innesto a spina maschio	Foro ø 4 mm/Hole ø 4 mm	0,75 ÷ 2,0mm ²	Ottone/Brass	-
01882C	7	Terminali con innesto a spina maschio	Foro ø 4 mm/Hole ø 4 mm	0,75 ÷ 2,0mm ²	Ottone/Brass	10 pz
01883	8	Terminali con innesto a spina femmina	Foro ø 3,9 mm/Hole ø 3,9 mm	0,8 ÷ 2,5mm ²	Ottone/Brass	-
01883C	8	Terminali con innesto a spina femmina	Foro ø 3,9 mm/Hole ø 3,9 mm	0,8 ÷ 2,5mm ²	Ottone/Brass	10 pz
09182	9	Terminali tubolari L 47mm	Vite M8/M8 Screw	35 mm ²	Bronzo stagnato	-
09183	9	Terminali tubolari L 47mm	Vite M10/M10 screw	35 mm ²	Bronzo stagnato	-

TERMINALI PREISOLATI

COSES PLATES ISOLEES
INSULATED TERMINALS
FLACHSTECKHULSE
TERMINAL PREAISLANTE



Note: PVC 300V

Notes: PVC 300V

Art./Ref.	Tipo/Type	Sezione/Section	Misure/Sizes	Colore/Color
51750	Femmina/Female	0,25÷1,65 mm ²	6,4x0,8mm	Rosso/Red
51751	Femmina/Female	1,04÷2,63 mm ²	4,8x0,5mm	Blu/Blue
51752	Femmina/Female	1,04÷2,63 mm ²	6,4x0,8 mm	Blu/Blue
51753	Femmina/Female	2,63÷6,64 mm ²	6,4x0,8mm	Giallo/Yellow
51754	Femmina/Female	2,63÷6,64 mm ²	9,4x1 mm	Giallo/Yellow

TERMINALI TOTALMENTE ISOLATI

COSES ISOLEES
FULLY INSULATED TERMINALS
FLACHSTECKHULSE
TERMINAL TOTALMENTE AISLANTE



Note: PVC 300V

Notes: PVC 300V

Art./Ref.	Tipo/Type	Sezione/Section	Misure/Sizes	Colore/Color
51755	Femmina/Female	0,25÷1,65 mm ²	6,4X0,8 mm	Rosso/Red
51756	Femmina/Female	1,04÷2,63 mm ²	6,4x0,8 mm	Blu/Blue
51757	Maschio/Male	0,25÷1,65 mm ²	6,35x0,8 mm	Rosso/Red
51758	Maschio/Male	1,04÷2,63 mm ²	6,35x0,8 mm	Blu/Blue

TERMINALI DOPPIA TENUTA

CLIP MIXTES
PIGGY-BACK TERMINALS WITH COPPER SLEEVE
STECKVERTEILER
TERMINAL FASTON 6,3 MM. PARA CABLE



Note: PVC

Notes: PVC

Art./Ref.	Sezione/Section	Misure/Sizes	Colore/Color
51759	0,25÷1mm ²	6,3x0,8mm	Rosso/Red
51760	1÷2,5mm ²	6,3x0,8mm	Blu/Blue

TERMINALI PREISOLATI AD OCCHIELLO

COSES RONDES
INSULATED RING TERMINALS
KABELRING
TERMINAL FASTON REDUNDO



Note: PVC 600V

Notes: PVC 600V

Art./Ref.	Sezione/Section	Diametro mm/Diameter mm	Colore/Color
51761	1,04÷2,63mm ²	ø 3,7 mm	Blu/Blue
51762	1,04÷2,63mm ²	ø 5,3 mm	Blu/Blue
51763	1,04÷2,63mm ²	ø 6,4 mm	Blu/Blue
51764	1,04÷2,63mm ²	ø 8,4 mm	Blu/Blue
75940	1,5÷2,5mm ²	ø 10mm	Blu/Blue
51765	2,63÷6,64mm ²	ø 8,4 mm	Giallo/Yellow
51766	2,63÷6,64mm ²	ø 10,5 mm	Giallo/Yellow

TERMINALI CILINDRICI TOTALMENTE ISOLATI

COSES CYLINDRIQUES 100% ISOLEES
FULLY INSULATED BULLET TERMINALS
RUNDSTECKER UND RUNDSTECKHULSE
TERMINAL PRE-AISLADO



Note: PVC 300V

Notes: PVC 300V

Art./Ref.	Tipo/Type	Sezione/Section	Colore/Color
51767	Femmina/Female	1,04÷2,63mm ²	Blu/Blue
51768	Maschio/Male	1,04÷2,63mm ²	Blu/Blue

PINZA PER CAPICORDA

PINCES A SERTIR POUR COSES ISOLEES
CRIMPING TOOLS
ZANGE FÜR KABELSCHUH
ALICATE PARA EXTREMIDADES DEL CABLE



Art./Ref.	Sezione/Section	Note/Note
06299	0,25÷6,0mm ²	Impugnatura in nylon isolante - tacche per spelatura fili / Isolating nylon hand grip - notches for cable skiving

COPRITERMINALI

COUVRE COSSES
 TERMINAL COVERS
 ISOLIERENDE GEHAUSE
 TAPAS COPRIFASTON



Art./Ref.	Tipo/Type	Note/Note
02581	Copritermine per femmina da 6,35mm/ Terminal cover for 6,35mm female	Polietilene (PE)
02146	Copritermine per maschio da 6,35mm/ Terminal cover for 6,35mm male	Polietilene (PE)

CONNETTORI MULTIPLI

CONNECTORS MULTIPLES
 MULTIPLE CONNECTORS
 STECKGEHAUSE
 CONECTOR - FASTON

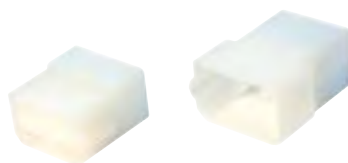

Art./Ref.	Tipo/Type	Modello/Model
12492	Femmina/Female holder	1 via
12493	Maschio/Male holder	1 via
12582	Femmina/Female holder	2 vie
12583	Maschio/Male holder	2 vie
12584	Femmina/Female holder	3 vie
12585	Maschio/Male holder	3 vie
12586	Femmina/Female holder	4 vie
12587	Maschio/Male holder	4 vie
12588	Femmina/Female holder	6 vie
12589	Maschio/Male holder	6 vie
12590	Femmina/Female holder	8 vie
12591	Maschio/Male holder	8 vie
12592	Femmina/Female holder	11 vie
12593	Maschio/Male holder	11 vie

MORSETTI DI DERIVAZIONE

BORNES DE DERIVATION
 SHUNT CABLE CLAMPS
 ABZWEIG-VERBINDER
 MORDAZAS



Note: Materiale: polietilene (PA) 600V

Notes: Materiale: polietilene (PA) 600V

Art./Ref.	Sezione/Section	Colore/Color	Dimensioni/Sizes
11915	0,25 ÷ 1,65 mm ²	Rosso/Red	20x27 mm
11916	1,04 ÷ 2,63mm ²	Blu/Blue	20x27 mm

CONNETTORI BIPOLARI 50A 600V

CONNECTEURS BIPOLAIRE 50A 600V
 2 POLE CONNECTOR 50A 600V
 KUPPLUNGSTUECKE SB-SBX UL/CSA-ZUGELASSEN
 CONECTORES SB-SBX CON CERTIFICACIÓN UL-CSA



Art./Ref.	Sezione/Section	Colore/Color
17421	13,5 mm	Grigio/Grey
17422	13,5 mm	Rosso/Red

CONNETTORI MASCHIO CONNEX CON PIASTRINA

CONNECTEURS CONNEX
 CONNEX CONNECTOR WITH PLATE
 STECKGEHAUSE CONNEX
 CONEXIONES CONNEX

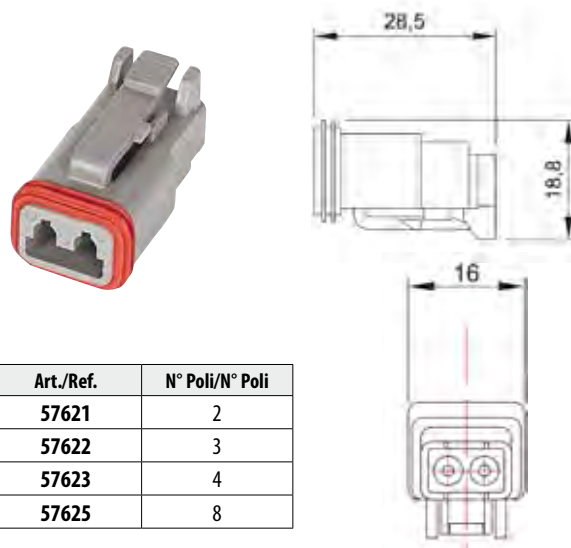

Art./Ref.	N° Poli/N° Poli
57621	2
57622	3
57623	4
57625	8

CONNETTORI FEMMINA CONNEX CON PIASTRINA

CONNECTEURS CONNEX
 FEMALE CONNEX PLUGS WITH PLATE
 STECKGEHAUSE CONNEX
 CONEXIONES CONNEX

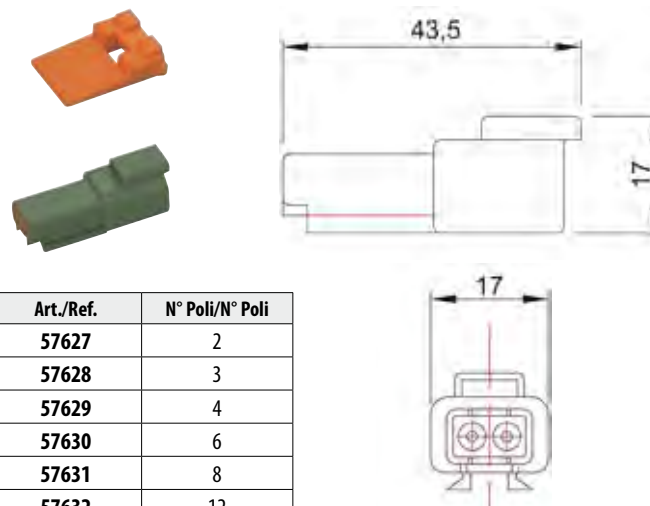

Art./Ref.	N° Poli/N° Poli
57627	2
57628	3
57629	4
57630	6
57631	8
57632	12

TERMINALE FEMMINA

TERMINAL FEMELLE CONNEX
 CLIP FEMALE CONNEX
 STECKHÜLSE (FEMALE)
 TERMINAL HEMBRA



Art./Ref.	Ampere/AMP
57683	15

TERMINALE MASCHIO CONNEX

TERMINAL MALE CONNEX
 CLIP MALE CONNEX
 STECKHÜLSE (MALE) CONNEX
 TERMINAL MACHO

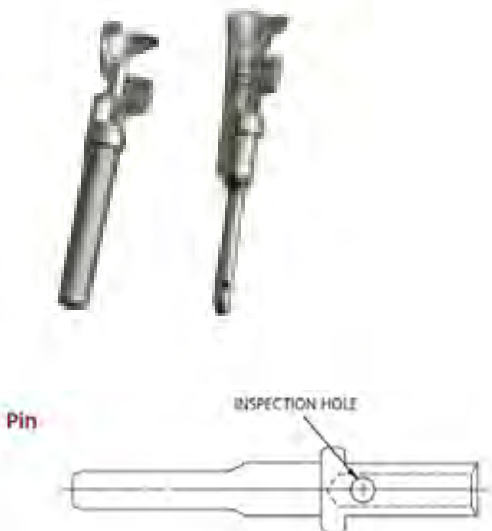

Art./Ref.	Ampere/AMP
57684	15

1.8.14 Intermittenze e Relays

Relays and flashing units



Ricambi & accessori per macchine agricole SPARE PARTS & ACCESSORIES FOR AGRICULTURAL MACHINE

Tutti gli articoli della presente sezione, prodotti da AMA SPA e/o da terzi per conto di AMA, sono adattabili ("non originali") alle marche indicate ai sensi di quanto previsto dal REG. CE n. 1400/2002. I diritti sui marchi citati appartengono ai legittimi proprietari ed il loro uso ha l'esclusiva finalità di consentire all'utilizzatore la comparazione dei diversi prodotti. All items of this section, manufactured by AMA SPA and/or any third party on behalf of AMA, are adaptable ("non-original") to the brands listed under the provisions of the REG. CE n. 1400/2002. The rights on the trademarks belong to their respective owners and their usage is only aimed to allow the user to compare different products.

CENTRALINA PRERISCALDO 12 V PER MOTORI LOMBARDINI

RELAIS DE PRECHAUFFAGE 12 V POUR MOTEUR LOMBARDINI
 PREHEATING RELAYS DIESEL 12 V FOR LOMBARDINI'S ENGINE
 GLÜHZEITRELAIS DIESEL 12 V FÜR MOTOREN LOMBARDINI
 RELAIS DE PRECALENTAMIENTO 12 V PARA MOTORES LOMBARDINI

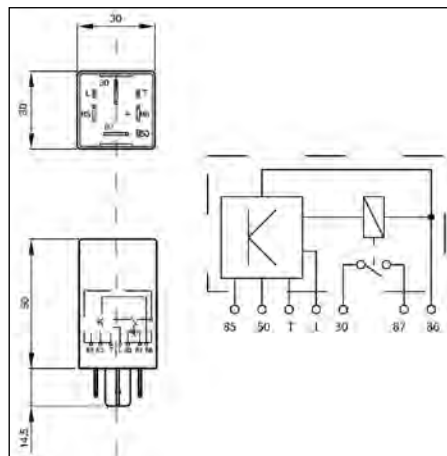
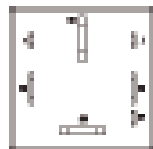
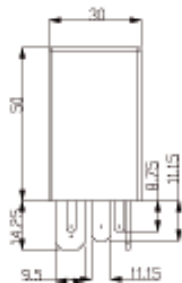
Note:

Art. 57689: base per relè
 Art. F22025 3pz.: terminale 2,8
 Art. F22039 2pz.: terminale 6,3
 Art. F22047 2pz.: terminale 9,5

Notes:

Pn. 57689: bracket
 Pn. F22025 3 pcs.: 2,8 clip
 Pn. F22039 2 pcs.: 6,3 clip
 Pn. F22047 2 pcs.: 9,5 clip

Art./Ref.	Volt/Volt	Note/Note	Brand	Rif. Orig./Orig. Ref.
09179	12 V	Senza staffa/Without bracket	LOMBARDINI	2193.111

INTERMITTENZE UNIVERSALI PER MACCHINE OPERATRICI E RIMORCHI

CENTRALE CLIGNOTEUR
 FLASHER UNIT
 BLINKREGLER
 INTERMITENCIA UNIVERSAL PARA MÁQUINAS OMBRADORAS Y REMOLQUES

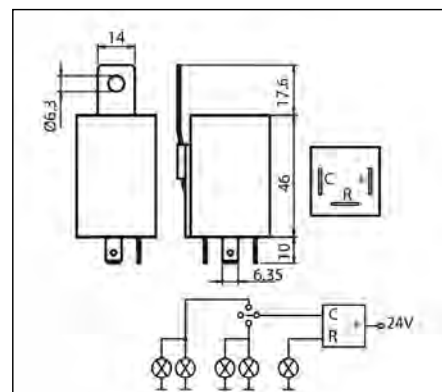
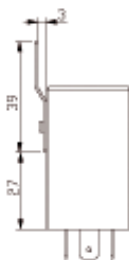
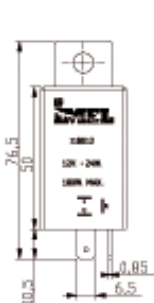
Note:

Art. I18006: base per relè
 Art. F22039 3pz.: terminale 6,3

Note:

Pn. I18006: bracket
 Pn. F22039 3pcs.: 6,3 clip

Art./Ref.	Volt/Volt	Watt/Watt	Modello/Model
00707	12 V	47W-180W max	Con spia e supporto
I18013	24 V	47W-180W max	Con spia e supporto

INTERMITTENZA ELETTRONICA A 6 POLI

CENTRALE CLIGNOTEUR ELECTRONIQUE 6 VOIES
 6-POLES ELECTRONIC INTERMITTENCE
 6-POLE ELEKTRONIK INTERMITTENZ
 INTERMITENCIA ELECTRÓNICA CON 6 POLOS

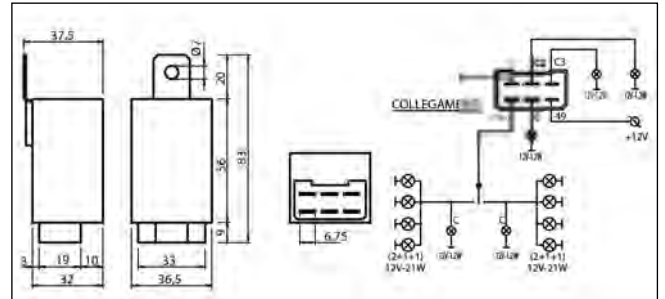

Note:
 Art. F22075: base per relè
 Art. F22039 6pz.: terminale 6,3

Note:
 Pn.F22075: bracket
 Pn. F22039 6pcs.: 6,3 clip

Art./Ref.	Volt/Volt	Watt/Watt	Modello/Model	Note/Note	Brand	Rif. Orig./Orig. Ref.
00708	12 V	(2+1+1)x 21(8x21)W	Con spia e supporto	6 Terminali/6 Terminals	FIAT - MASSEY FERGUSON	5154278, 1672755M1

INTERMITTENZA

CLIGNOTEUR
 FLASHER
 INTERMITTENZ
 INTERMITENCIA

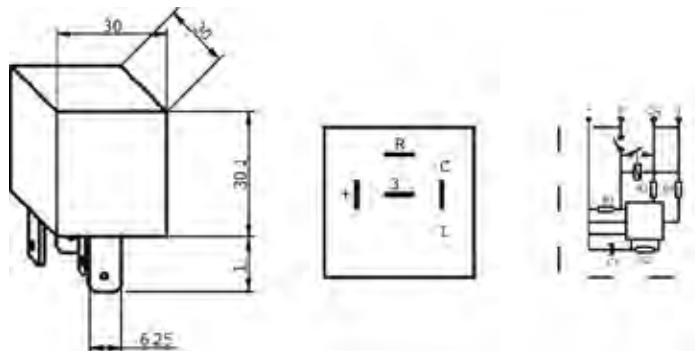

Note: Art. I18006: supporto
 Art. F22039 4pz.: terminali
 Certificati:
 ISO 7588
 ISO 8092
 DIN 46244
 DIN 40050: IP54
 10 ECE-ONU/02
 2002/95/EC RoHS

Notes: Pn. I18006: bracket
 Pn. F22039 4 pcs.: terminals
 In conformity with:
 ISO 7588
 ISO 8092
 DIN 46244
 DIN 40050: IP54
 10 ECE-ONU/02
 2002/95/EC RoHS

Art./Ref.	Volt/Volt	Watt/Watt	Modello/Model	Note/Note
L18082	12	2(4)x21W	Con spia	4 Terminali/4 Terminals

RELAYS

RELAIS
RELAYS
EINSCHALTERRELAIS
RELAIS

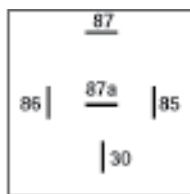
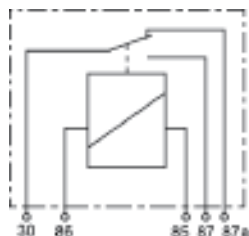

Note:
Art. I8006: base per relè
Art. F22039 5 pz. terminale 6,3,

Notes:
Pn. I8006: bracket
Pn. F22039 5 pcs. 6,3 clip

Art./Ref.	Volt/Volt	Watt/Watt	Brand	Rif. Orig./Orig. Ref.
02101	12 V	20/30	FIAT	5117800, 5155317, 5168572
02102	24 V	10/20	-	-

RELAYS

RELAIS
RELAYS
EINSCHALTERRELAIS
RELÉS

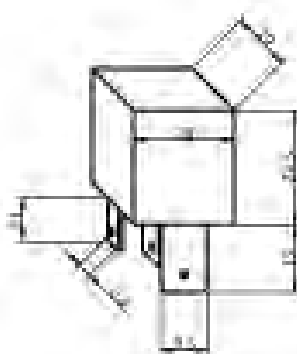
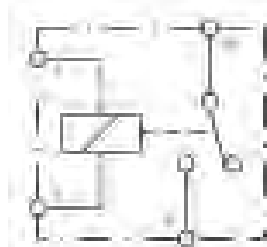

Note:
Art. 57689: base
Art. F22047 2pz. terminale 9,5
Art. F22039 2pz. terminale 6,3

Note:
Pn. 57689: bracket
Pn. F22047 2pcs. 9,5 clip
Pn. F22039 2pcs. 6,3 clip

Art./Ref.	Volt/Volt	Ampere/AMP
57688	12 V	70
60064	24 V	40

MICRO-RELAYS

MICRO-RELAIS
MICRO-RELAY
MIKRORELAIS
MICRO-RELÈ

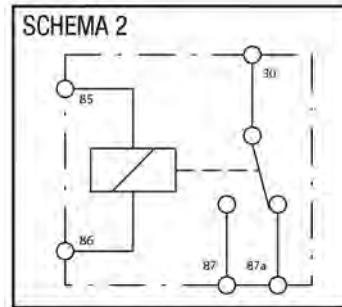
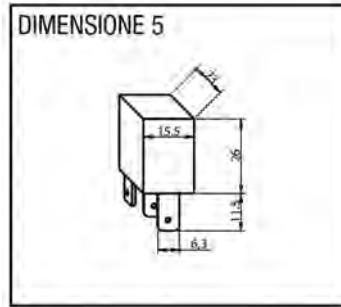

Note:

Art. I18099: base
Art. F22039 2pz. terminale 6,3
Art. F22041 3pz. terminale 4,8

Note:

Art. I18099: bracket
Art. F22039 2pcs. 6,3 clip
Art. F22041 3pcs. 4,8 clip

Art./Ref.	Volt/Volt	Ampere/AMP
60061	12V	15/25
60062	24V	5/10

BLOCCHETTO PORTA RELAIS A CROCE

BOÎTIER PORTE RELAIS
HOUSING RELAYS
RELAISHALTER
PORTARELAIS A CRUZE



1



2



3

Art./Ref.	Pos.	Applicazione/Application
12490	1	02101, 02102
57689	2	57688
I18006	3	02101, 02102, I18082, 00707, I18013

ANTIFURTO PER TRATTORE E MACCHINA MOVIMENTO TERRA DA 24V.

ANTIVOL POUR TRACTEURS ET MACHINES TRAVAIL DU SOL 24 V.
24 ALARM SUITABLE FOR TRACTORS & EARTH MOVING MACHINES
DIEBSTAHLSICHERUNG 24 V FÜR LANDMASCHINEN
ANTI-ROBO PARA TRACTORES Y MÁQUINAS MOVIMIENTO TIERRA DE 24 V.



Art./Ref.
34594

RICEVITORE DI POTENZA 2/4 RELÈ 16A ALIM. 12/24 VAC/DC P/N

RÉCEPTEUR 2/4 RELÈ 16A ALIM. 12/24 VAC/DC P/N

RECEIVERS 2/4 RELAYS 16A ALIM. 12/24 VAC/DC P/N

LEISTUNGSEMPFÄNGER 2/4 RELÈ 16A ALIM. 12/24 VAC/DC P/N

RECEPTOR DE POTENCIA 2/4 RELÈ 16A ALIM. 12/24 VAC/DC P/N

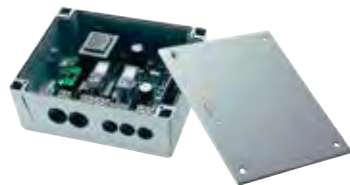

Note: Il ricevitore è un ricevitore supereterodina. È concepito per comandare automatismi generici, grazie a una codifica ad altissima sicurezza (KeeLoq Hopping code). La frequenza e le tecnologie impiegate lo rendono conforme alle regolamentazioni europee in termini di radiofrequenza e di compatibilità elettromagnetica (CE). Il codice ricevuto dal trasmettitore cambia a ogni attivazione, evitando il rischio della copia e successiva riproduzione. Un sistema interno permette di mantenere sempre sincronizzati ricevitore e trasmettitore. Il ricevitore, dispone di 2 o 4 relè di uscita con contatti puliti del tipo NA e di uno con contatti NA /NC; può essere perciò collegato a un qualsiasi tipo di meccanismo (fino a 4 dispositivi differenti). La memorizzazione dei trasmettitori si effettua sia mediante i tasti del ricevitore sia a distanza, per autoapprendimento, per mezzo dei tasti del trasmettitori. Tutti i ricevitori sono in grado di apprendere e conservare in EEPROM il codice di serie e l'algoritmo di sincronizzazione di più trasmettitori.

Notes: The receivers are superheterodyne. The product has been designed for the control of automatic systems, thanks to its very high security coding system (KeeLoq® Hopping code). The operating frequency is among the European harmonised frequencies; the product fully complies with the EMC European Regulations (CE). The code sent by the transmitter changes at every activation, avoiding any scanning and copying risk. A special algorithm allows to keep synchronised transmitter and receiver. The receiver, which makes the activation, once received the transmitter code, has to be connected during the installation to the device to control. The receiver has 2/4 output relays, with NO (Normally open) and NO/NC (Normally open and normally closed) contacts. It can be connected to any type of appliance. The user codes can be memorised both with the receiver buttons and, via radio, in self-learning, using the transmitter keys. All the receivers Series can manage the serial number and the synchronisation algorithm of many transmitters.

Tipo ricevitore Supereterodina

Frequenza portante 433,92 MHz

Frequenza oscillatore locale 6,6128 MHz

Modulazione AM/ASK - FM/FSK

Impedenza d'ingresso 50 Ohm

Larghezza di canale > 25 KHz

Frequenza intermedia 10,7 MHz

Sensibilità d'ingresso -115 dBm

Emissione dell'oscillatore locale < -57 dBm

Tensione di alimentazione 12 - 24 Vac-dc

Consumo max 200 mA @24 Vac 260 mA @12 Vac

Potenza massima applicabile ai contatti dei relè 3,5 KW / 230 Vac

N° max codici utente 85

Temperatura di funzionamento -20°/+70°C

Grado di protezione IP44

Peso 300 gr

Dimensioni (mm) 140 x 115 x 52

Receiver type Superheterodyne

Carrier frequency 433.92 MHz

Local oscillator frequency 6,6128 MHz

Modulation AM/ASK - FM/FSK

Input impedance 50 Ohm

Channel length > 25 KHz

Intermediate frequency 10,7 MHz

Input sensitivity -115 dBm

Local oscillator emissions < -57 dBm

Power supply 12 - 24 Vac-dc

Consumption 200 mA @ 24 Vac 260 mA @12 Vac

Max applicable power at relay contacts 3,5 KW / 230 Vac

User codes max 85

Operating temperature -20°/+70°C

IP Grade IP44

Weight 300 gr

Overall dimensions (mm) 140 x 115 x 52

Selflearning radio memorization yes

Art./Ref.	Note/Note
1001806	RICEVITORE 4 CH, AM, 12/24 Vac/dc/RECEIVERS 4 CH, AM, 12/24 Vac/dc
1001807	RICEVITORE 2 CH, FM, 12/24 Vac/dc/RECEIVERS 2 CH, FM, 12/24 Vac/dc
1001809	RICEVITORE 4 CH, FM, 12/24 Vac/dc/RECEIVERS 4 CH, FM, 12/24 Vac/dc

1.8.15 Avvisatori Acustici

Horns



Ricambi & accessori per macchine agricole

SPARE PARTS & ACCESSORIES FOR AGRICULTURAL MACHINE

Tutti gli articoli della presente sezione, prodotti da AMA SPA e/o da terzi per conto di AMA, sono adattabili ("non originali") alle marche indicate ai sensi di quanto previsto dal REG. CE n. 1400/2002. I diritti sui marchi citati appartengono ai legittimi proprietari ed il loro uso ha l'esclusiva finalità di consentire all'utilizzatore la comparazione dei diversi prodotti. All items of this section, manufactured by AMA SPA and/or any third party on behalf of AMA, are adaptable ("non-original") to the brands listed under the provisions of the REG. CE n. 1400/2002. The rights on the trademarks belong to their respective owners and their usage is only aimed to allow the user to compare different products.

AVVISATORE ELETTROMAGNETICO

KLAXON
WARNING SIGNAL
HUPE
CLAXON 12V

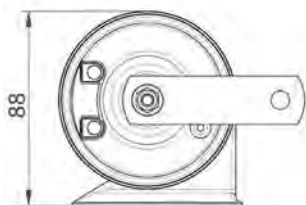

Note: Art. 02101 relay 12V 20/30A

Certificazioni: CEE 70/388 - R.28 ECE/ONU - CEE 93/30, RoHS

Notes: Pn 02101 relay 12V 20/30A

CEE 70/388 - R.28 ECE/ONU - CEE 93/30, RoHS approval

Art./Ref.	Volt/Volt	DB/DB	Corrente assorbita/Current consumption	Frequenza/Frequency	Intensità suono/Sound intensity
01354	12 V	109dB(A)	4A	500 +/- 5%	Acuto

AVVISATORE ACUSTICO ELETTROMAGNETICO A DISCO

AVVERTISSEUR SONORE
HORN
HUPE
AVISADOR ACÚSTICO



Note: Certificazioni: CEE 70/388 - R.28 ECE/ONU - CEE 93/30, RoHS

Notes: CEE 70/388 - R.28 ECE/ONU - CEE 93/30, RoHS approval

Art./Ref.	Volt/Volt	DB/DB	Corrente assorbita/Current consumption	Frequenza/Frequency	Intensità suono/Sound intensity	Brand	Rif. Orig./Orig. Ref.
00437	12V	114 dB(A)	4A	430+/-5% Hz	Acuto	FIAT	4117018, 5100341, 5107692, 5169413
04508	24V	114 dB(A)	1,5A	430+/-5% Hz	Acuto	-	-
04509	36/48V	114 dB(A)	1A	430+/-5% Hz	Acuto	-	-

AVVISATORE ACUSTICO RETROMARCIA CON STAFFA PER FISSAGGIO

AVERTISSEUR
WARNING
RÜCKWÄRTSGANG
ZUMBADOR

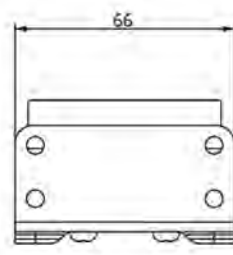
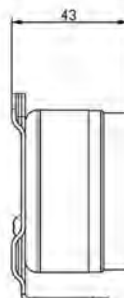
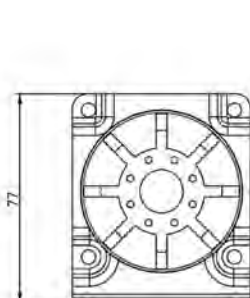
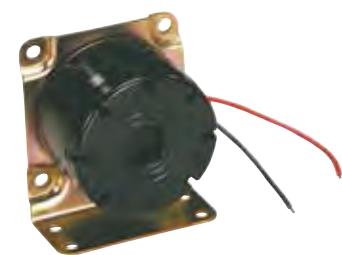

Note: Art. 15282: vite di fissaggio **Notes:** Pn 15282: fixing screw

Art./Ref.	Volt/Volt	DB/DB	Intensità suono/Sound intensity	Frequenza/Frequency	Note/Note
27244	12V	112 dB	Intermittente	300mA	IP54

CICALINO RETROMARCIA

AVERTISSEUR MARCHE ARRIERE

REVERSE WARNING

SUMMER RÜCKWÄRTSGANG

ZUMBADOR MARCHA ATRÁS

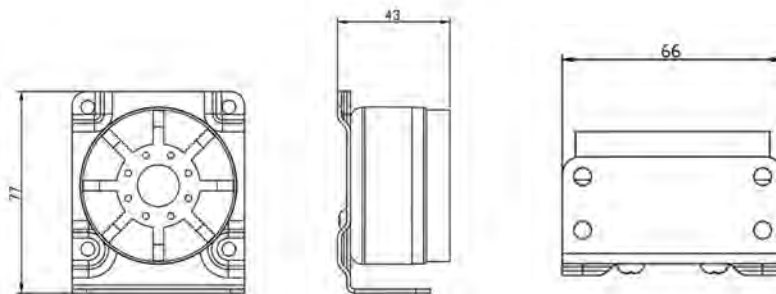
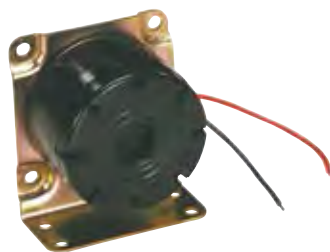

Art./Ref.	Volt/Volt	DB/DB	Intensità suono/Sound intensity	Frequenza/Frequency	Corrente assorbita/Current consumption	Note/Note
19732	10-100V	min.90dB	Tono a impulsi	2,800±0,2Hz	200mA	IP 67 Certificati: EMC Compliance, CE
09865	12V	108dB	Intermittente	2.8± 0.4kHz	300mA	IP54
09866	24V	108dB	Intermittente	2.8± 0.4kHz	300mA	-

CICALINO DA PANNELLO BITONALE

AVERTISSEUR

WARNING

RÜCKWÄRTSGANG

ZUMBADOR

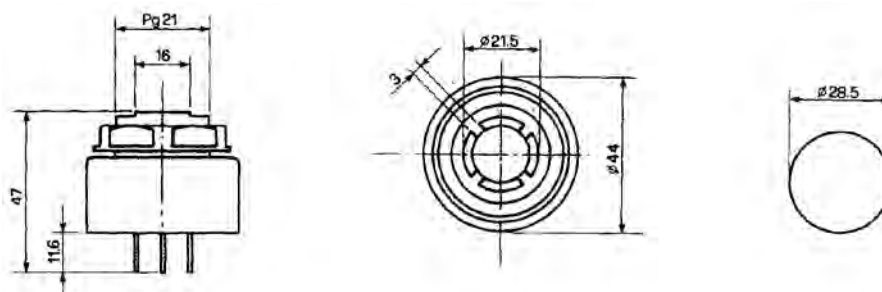
**Note:**

IP 65 Grado di protezione

Temperatura di esercizio: -30 °C + 80 °C

Protetto contro l'inversione di polarità

Notes:

IP 65 protection grade

Working temperature: -30°C +80°C

Protected against polarity inversion

Art./Ref.	Volt/Volt	Intensità suono/ Sound intensity	Frequenza/ Frequency	Corrente assorbita/ Current consumption	Note/Note
27243	5-32	(5V -70 dB) (32V -80 dB)	2400 ± 500 Hz	3 -18 mA	Intermittente 2 ±10 % Continuo / Intermittent 2 ±10 % Continuous Protetto da inversioni di polarità/ Protected against polarity inversion

1.8.16 Accessori cabina

Cabin accessories



Ricambi & accessori per macchine agricole

SPARE PARTS & ACCESSORIES FOR AGRICULTURAL MACHINE

Tutti gli articoli della presente sezione, prodotti da AMA SPA e/o da terzi per conto di AMA, sono adattabili ("non originali") alle marche indicate ai sensi di quanto previsto dal REG. CE n. 1400/2002. I diritti sui marchi citati appartengono ai legittimi proprietari ed il loro uso ha l'esclusiva finalità di consentire all'utilizzatore la comparazione dei diversi prodotti. All items of this section, manufactured by AMA SPA and/or any third party on behalf of AMA, are adaptable ("non-original") to the brands listed under the provisions of the REG. CE n. 1400/2002. The rights on the trademarks belong to their respective owners and their usage is only aimed to allow the user to compare different products.

KIT VIDEORETRO 7" LCD
KIT VIDEO RETRUISEUR 7" LCD
KIT RETRO-SCREEN LCD 7
KONTROLLSATZ RUECKWAERTSGANG
SISTEMA DE CAMERAS LCD

Art./Ref.	Pos.	Tipo/Type	Volt/Volt	Note/Note
80819		Kit completo videoretro	12-24 V	-
84693	2	Monitor a colori	-	Accensione automatica con inserimento retromarcia . Risoluzione monitor: 800 R.G.B x480 . Selezione lingua (EN, IT, GE, RA, SP, FR, Deutch) . Protezione voltaggio . Ampio angolo di visualizzazione (>10): (Superiore/inferiore/Sx/Dx): 40/40/60/60 . Alimentazione: 75W . Temperatura di esercizio: -20°C~+50°C . /Automatically switch on when we put the reverse in the machines . Monitor resolution: 800 R.G.B x480 . 7 languages (EN, IT, GE, RA, SP, FR, Deutch) . Low e high voltage self-protection . Wide-angle viewing (>10): (Top/Bottom/Left/Right): 40/40/60/60 .Power: 75W .Working temperature: -20°C~+50°C/
84694	3	Camera con microfono	12V	La telecamera utilizza un sensore SHARP/ CCD che fornisce un'alta qualità delle immagini . Corpo in alluminio . Risoluzione PAL: 512(H)×582(V) NTSC: 512(H)×492(V) . Cavo: 420 fili . Visione notturna . Raggi infrarossi a led: 18 . Distanza visiva: 10-50m . Angolo di visione 120° . Temperatura di esercizio: -20°C~70°C . IP67 . /SHARP/ CCD camera . Aluminum house . Resolution: PAL: 512(H)×582(V) NTSC: 512(H)×492(V) . Cable: 420 wires . Night vision . Infrared ray LED: 18PCS . Viewing distance: 10-50m . Viewing angle: 120° . Working temperature: -20°C~70°C . Water-proof: IP67
84689	4	Cavo	-	Lunghezza cavo: 20 mt

KIT VIDEORETRO LCD 7" A COLORI WIRELESS CH3

SYSTEME DE CAMERA SANS FIL LCD 7"
 7" LCD WIRELESS SECURITY CAMERA SYSTEM
 WIRELESS-SICHERHEIT KAMERA-SYSTEM
 SISTEMA DE CAMERAS INALAMBIRICA LCD 7"



Art./Ref.	Descrizione/Description	Volt/Volt	Descrizione estesa/Descrizione estesa
88103	Kit completo videoretro	10-32 V	Kit videoretro wireless a colori 10-32 V in grado di supportare 4 telecamere. Risoluzione monitor 800x480. Immagine regolabile. Visione notturna: 22 m (28 m con infrarossi). wireless security camera syste
85446	Monitor LCD a colori	-	Monitor lcd 7" wireless a colori, risoluzione 800x3 (RGB)x480. Angolo di visualizzazione (superiore/inferiore/dx/sx) 50/60/70/70. Temperatura di esercizio -20°/+50° C. Alimentazione 6 W
85447	Camera con microfono CH3	-	Camera CH3 Con microfono Pixel: 728x488 Risoluzione: 500TV linee Visione notturna Angolo di visione 120° Temperatura di esercizio: -40°C + 70°C
85464	Camera con microfono aggiuntiva CH1	-	Camera aggiuntiva CH1 Con microfono Pixel: 728x488 Risoluzione: 500TV linee Visione notturna Angolo di visualizzazione 120° Temperatura di esercizio: -40°C + 70°C

KIT VIDEORETRO LCD 7" WIRELESS E CON FUNZIONE DI REGISTRAZIONE IMMAGINI

SYSTEM DE CAMERA SANS FIL AVEC IMAGE RECORDER
 WIRELESS RV SYSTEM WITH RECORD
 WIRELESS-UEBERWACHUNGS-KAMERA-SYSTEM
 SISTEMA DE CÁMARAS INALAMBIRICA CON IMAGEN GRABADORA



Art./Ref.	Descrizione/Description	Volt/Volt	Descrizione estesa/Descrizione estesa
85556	Kit completo videoretro	10 - 32V	Kit videoretro LCD 7" wireless e registrazione immagini Micro SD per registrazione non inclusa Può supportare 4 Telecamere Risoluzione monitor 800x3 (RGB)x480 A colori Immagine regolabile Visione notturna: 10m (12 luci infrarossi)
85557	Monitor LCD a colori	-	Monitor LCD 7" Risoluzione: 800x3 (RGB)x 480 Angolo di visualizzazione: (Superiore/inferiore /dx e sx) 50/70/70 Distanza di trasmissione: 120 m Proporzioni 16: 9 Temperatura di esercizio: -20°C +70°C Alimentazione: 6W SD CARD: Max 32G
85558	Camera CH3 con microfono	-	Camera CH3 con microfono Pixel: 728x488 Risoluzione: 500TV lines Zona di rilevamento: 4.6228mmx36112mm Distanza di trasmissione: 120M Alimentazione: DC10 - 32V Tempertaura di esercizio: -20°C + 70°C

ACCENDISIGARI 12V

ALLUME-CIGARE 12V
12V CIGAR LIGHTER
ZIGARETTENANZÜENDER 12V
ENCENDEDOR 12V



Art./Ref.	Volt/Volt	Dima mm/Dima
58568	12V	28 mm

SPINOTTO PER ACCENDISIGARI

FICHE POUR ALLUME CIGARE 5A
PLUG FOR CIGARETTE LIGHTER 5A
ANSCHLUSSTECKER FÜR ZIGARETTENANZÜNDER 5A
ENCHUFE PARA MECHERO 5 A

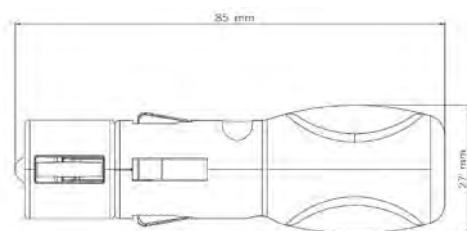

Art./Ref.	Specifiche/Specifications
60069	5A

BRACCI PER TERGICRISTALLO

BRAS ESSUIE - GLACE
WIPER ARMS
SCHEIBENWISCHERARM
BRAZOS PARA LIPIAPARABRIASAS

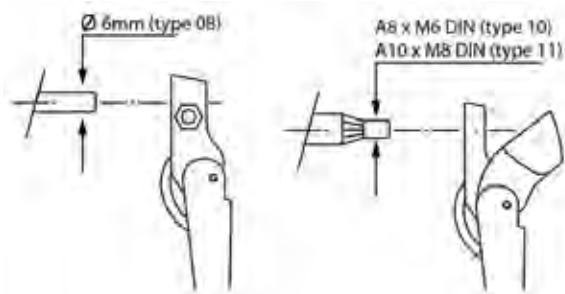

Art./Ref.	Tipo/Type	Lunghezza mm/Lenght mm	Attacco/Connection	Specifiche/Specifications	Applicazione/Application	Ricambio/Replacement
01308	Regolabile/ Adjustable	300-400 mm	Attacco cilindrico con grano 6mm/ Cylindrical connection	Sezione 8x3.0/Section 8x3.0	-	12459 - motore x tergicristalli 12v / 12v wiper motor 110 deg.
01304	Regolabile/ Adjustable	300-400mm	A8xM6	Sezione 7.1x2.5/ Section 7.1x2.5	01340, 01344	-
01311	Regolabile/ Adjustable	400-500 mm	A8xM6	Sezione 7.1x2.5/ Section 7.1x2.5	01340, 01344	-

BRACCI PER TERGICRISTALLO ATTACCO CURVO

BRAS ESSUIE - GLACE
WIPER ARMS
SCHEIBENWISCHERARM
BRAZOS PARA LIPIAPARABRIASAS



Art./Ref.	Lunghezza mm/Lenght mm	Tipo/Type	Attacco/Connection	Ø braccio/Ø arm
12465	382 mm	Curvo: piega negativa/bend negative	Att. gancio/ Hook connection C10XM8	Braccio 9x3

BRACCI PARALLELI PER TERGICRISTALLO

BRAS ESSUIE - GLACE
WIPER ARMS
SCHEIBENWISCHERARM
BRAZOS PARA LIPIAPARABRIASAS

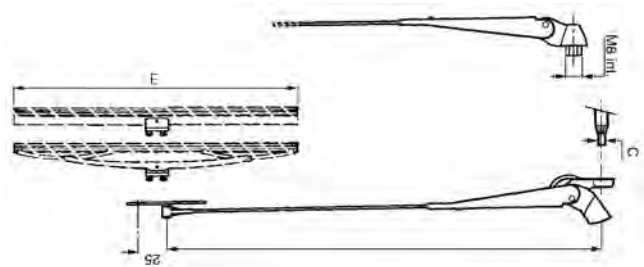

Art./Ref.	Lunghezza mm/Lenght mm	Attacco/Connection	Ø braccio/Ø arm	Note/Note
12467	453-533 mm	Forcella/Fork T i=57,5 2 viti C10XM8-B/M8	9x3 pantografo/pantograph	-
12468	475-525,5 mm	Forcella/Fork T i=57,5 2viti C10xM8-B/M8	9x3 pantografo/pantograph	Con spruzzatore lato sx/Whit sprayer on left side

MOTORI TERGICRISTALLI AD ATTACCO CONICO

MOTEURS D'ESSUIE-GLACE
WINDSCREEN WIPER MOTORS
SCHEIBENWISCHERMOTOREN
MOTORES LIMPIAPARABRISAS

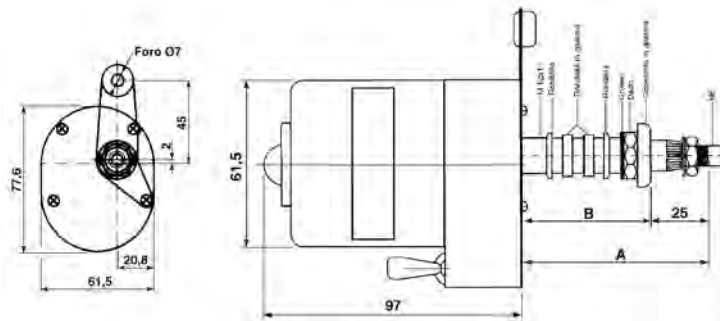

Note: Modelli con interruttore, senza posizione di arresto automatico, con fissaggio a due punti, singola velocità (40 cicli /minuto)
Bracci compatibili: art. 01304 e art. 01311

Notes: Conical type, with switch, without automatic stop position, 2 holes for fixing, single speed (40 rpm)
Wiper arms: pn 01304 and pn 01311

Art./Ref.	Volt/Volt	Angolo/Angle	A mm	B mm	Lunghezza bracci max mm/Max arm lenght mm	Attacco/Connection	Ø braccio/Ø arm	Specifiche/Specifications
12723	12V	85°	67	42	575 mm	A8xM6	M12x1	Consumo corrente/Current cons. a 12V: 0,8A
01340	12V	105°	67	42	575 mm	A8xM6	M12x1	Consumo corrente/Current cons. a 12V: 0,8A
01344	12V	105°	119	94	575 mm	A8xM6	M12x1	Consumo corrente/Current cons. a 12V: 0,8A

MOTORI TERGICRISTALLI

MOTEURS D'ESSUIE-GLACE
WINDSCREEN WIPER MOTORS
SCHEIBENWISCHERMOTOREN
MOTORES LIMPIAPARABRISAS

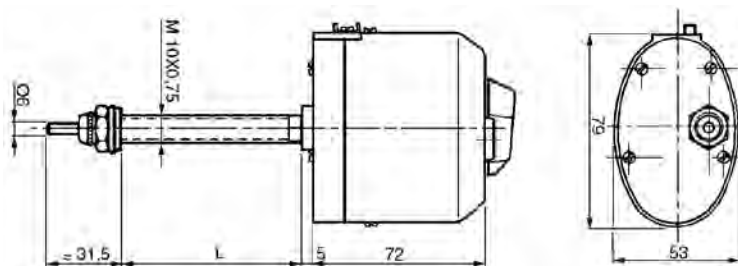

Note: Interruttore sul coperchio posteriore
Coppia di spunto a freddo 4,5 Nm
Torsione massima a regime 0,8 Nm
Tutti questi motori sono provvisti di un cuscinetto intercambiabile che permette di togliere il perno.

Notes: Switch on the rear bottom
Peak cold Torque 4,5 Nm
Max. running torision 0,8 Nm
These motors are equipped with interchangeable bearing, allowing to remove the pin.

Art./Ref.	Volt/Volt	Angolo/Angle	Attacco/Connection	Ø braccio/Ø arm	Lunghezza mm/Lenght mm	Specifiche/Specifications	Note/Note	Lunghezza bracci max mm/Max arm lenght mm
12459	12V	110°	M10x75mm	Ø 6mm cilindrico	Lunghezza albero 120mm Lunghezza di bloccaggio 84mm	40 cicli al minuto	Posizione di parcheggio non inclusa/Without parking position	500 mm

MOTORI PER TERGICRISTALLI PARALLELI

MOTEURS D'ESSUIE-GLACE
WINDSCREEN WIPER MOTORS
SCHEIBENWISCHERMOTOREN
MOTORES LIMPIAPARABRISAS

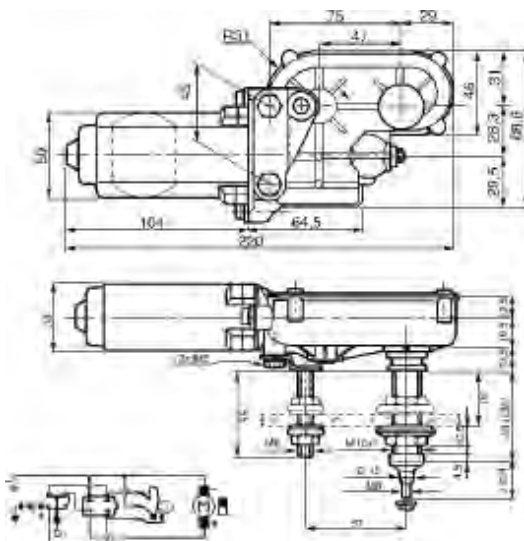

Dimensioni massime del braccio/Max. arm size

Note: Bracci tergi: Art. 12465 - 12467 - 12468

Notes: Wiper arms: Pn. 12465 - 12467 - 12468

Art./Ref.	Volt/Volt	Angolo/Angle	Tipo/Type	Attacco/Connection	Specifiche/Specifications	Lunghezza mm/Lenght mm	Connettore/Connettore
12461	12V	Angolo di oscillazione 90°	1 Velocità	A10XM8	Frequenza di oscillazione 45 Rpm	Lunghezza cavo 280mm	Connettore AMP
12462	24V	Angolo di oscillazione 90°	1 Velocità	A10xM8	Frequenza di oscillazione 60 Rpm	Lunghezza cavo 280mm	Connettore AMP

KIT UNIVERSALE LAVACRISTALLO CON ELETTROPOMPA 12 V - CAPACITA' 2 LT.

KIT UNIVERSEL ESSUIE-GLACE AVEC ELECTRO POMPE 12V CAPACITE' 12 LT.

WINDSCREEN-WIPER UNIVERSAL KIT WITH ELECTRO PUMP

SCHEIBENWASCHERKIT MIT ELEKTROPUMPE 12V - 2 LT

KIT UNIVERSAL LIMPIA CRISTAL CON ELECTRO BOMBA 12V



Art./Ref.	Volt/Volt	Blister/Packaging
57687	12 Volt	2 Lt

SPAZZOLE PER TERGICRISTALLO

BALAI POUR ESSUIE - GLACE

WIPER SPINDLES

SCHEIBENWISCHERBLATT

CEPILLO PARA LIMPIAPARABRISAS



Note: Bracci per tergicristalli compatibili art. 01308, art. 01304, art. 01311 **Notes:** Bracci per tergicristalli compatibili art. 01308, art. 01304, art. 01311

Art./Ref.	Lunghezza mm/Lenght mm
01283	400
01284	500

SPAZZOLE PER TERGICRISTALLO

BALAI POUR ESSUIE - GLACE

WIPER SPINDLES

SCHEIBENWISCHERBLATT

CEPILLO PARA LIMPIAPARABRISAS

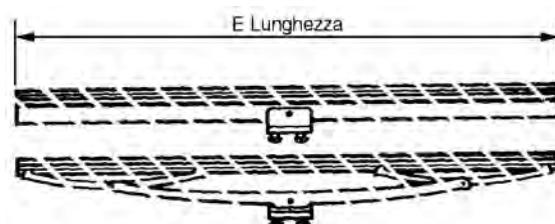

Note: Per bracci: art. 12467 e art. 12468 **Notes:** For arms: pn 12467 and pn. 12468

Art./Ref.	Lunghezza mm/Lenght mm	Attacco/Connection
12471	400 mm	Attacco a 2 viti l=14,5 (8x2,7/Forcella T)

MOLLE A GAS

RESSORTS A GAZ

GAS SPRINGS

GASDRUCKFEDERN

RESORTES A GAS



Art./Ref.	Corsa/ Stroke	Lunghezza bracci max mm/Max arm lenght mm	Newton/ Newton	Attacco/ Connection	Ø braccio/ Ø arm	Brand	Applicazione/ Application	Rif. Orig./ Orig. Ref.	Disegno/Drawing
05379	145 mm	360 mm	190 N	Terminale asta sfera Ø 10 mm, M8x1,25; ; Terminale tubo: foro Ø 6,2 mm	Asta: Ø 8 mm; Tubo: Ø 18 mm	BRIEDA	VETRO POSTERIORE / REAR WINDOW		
05381	150 mm	400 mm	200 N	Sfera Ø 10 mm, M8x1,25	Asta: Ø 8 mm; Tubo: Ø 18 mm		VETRI ANTERIORI / FRONT WINDOW		
05382	150 mm	400 mm	100 N	Sfera Ø 10 mm, M8x1,25	Asta: Ø 8 mm; Tubo: Ø 18 mm		SPORTELLI LATERALI/ SIDE DOORS		
05384	210 mm	510 mm	380 N	Sfera in plastica Ø 10 mm, M8x1,25	Asta: Ø 8 mm; Tubo: Ø 18 mm	DEUTZ		4357779	
05386	300 N	500 mm	300 N	Sfera Ø 10 mm, M8x1,25	Asta: Ø 8 mm; Tubo: Ø 18 mm		PORTIERA/DOOR DX3.10SC, PORTIERA/ DOOR DX3.30SC, POR- TIERA/DOOR DX3.60SC, PORTIERA/DOOR DX3.65SC	4373761	
05387	209 mm	500 mm	350 N	Sfera Ø 10 mm, M8x1,25	Asta: Ø 8 mm; Tubo: Ø 18 mm		PORTIERA/DOOR DX3.50SC, PORTIERA/ DOOR DX3.70SC, PORTIE- RA/DOOR DX3.90SC	4357776	
05389	170 mm	610 mm	140 N	Sfera Ø 10 mm, M8x1,25	Asta: Ø 8 mm; Tubo: Ø 18 mm		TUTTI I TRATTORI DOPO 10/87	4373763	

MOLLE A GAS

RESSORTS A GAZ
GAS SPRINGS
GASDRUCKFEDERN
RESORTES A GAS



Art./Ref.	Corsa/ Stroke	Lunghezza bracci max mm/Max arm length mm	New- ton/ Newton	Attacco/Connec- tion	Ø braccio/Ø arm	Brand	Applicazione/Application	Rif. Orig./ Orig. Ref.	Disegno/Drawing
05390	195 mm	490 mm	200 N	Terminali: Ø foro 8,2 mm	Asta: Ø 8 mm; Tubo: Ø 18 mm	FIAT	115.90DT, 1180DT, 1280DT, 130.90DT, 1380DT, 55.90DT, 60.90DT, 680DT, 80.90DT, VETRO POSTERIORE/REAR WINDOW	5113767, 5129427	
05391	200 mm	500 mm	250 N	Sfera Ø 10 mm, M8x1,25	Asta: Ø 8 mm; Tubo: Ø 18 mm	JOHN DEERE - FIAT - MASSEY FERGUSON	1180/DT, 1880/DT, 580/DT, 680/DT, 780/DT, 980/DT	9933355, AL 33170, 3384671M1	
05392	210 mm	495 mm	150 N	Terminale asta: sfera in plastica Ø 10 mm, M8x1,25; Terminale tubo: Ø foro 8,2 mm	Asta: Ø 8 mm; Tubo: Ø 18 mm	JOHN DEERE		AL 58521	
05393	75 mm	225 mm	150 N	Terminali: Ø foro 6,2 mm	Asta: Ø 8 mm; Tubo: Ø 18 mm		TETTuccio/ROOF 1040, TETTuccio/ROOF 1140, TETTuccio/ROOF 1550, TETTuccio/ROOF 1640, TETTuccio/ROOF 1750, TETTuccio/ROOF 1850, TETTuccio/ROOF 2040, TETTuccio/ROOF 2040S, TETTuccio/ROOF 2250, TETTuccio/ROOF 2450, TETTuccio/ROOF 2650, TETTuccio/ROOF 2850, TETTuccio/ROOF 940	AL 57248	
05394	200 mm	500 mm	200 N	Sfera in plastica Ø 10 mm, M8x1,25	Asta: Ø 8 mm; Tubo: Ø 18 mm		PORTIERA/DOOR 1040, PORTIERA/DOOR 1140, PORTIERA/DOOR 1550, PORTIERA/DOOR 1640, PORTIERA/DOOR 1750, PORTIERA/DOOR 1850, PORTIERA/DOOR 2040, PORTIERA/DOOR 2040S, PORTIERA/DOOR 2250, PORTIERA/DOOR 2450, PORTIERA/DOOR 2650, PORTIERA/DOOR 2850, PORTIERA/DOOR 940	AL 63124	

MOLLE A GAS

RESSORTS A GAZ

GAS SPRINGS

GASDRUCKFEDERN

RESORTES A GAS

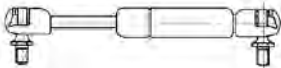
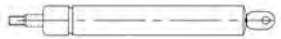

Art./Ref.	Corsa/ Stroke	Lunghezza bracci max mm/Max arm length mm	Newton/ Newton	Attacco/Con- nection	Ø braccio/Ø arm	Brand	Applicazione/Application	Rif. Orig./ Orig. Ref.	Disegno/Drawing
05391	200 mm	500 mm	250 N	Sfera Ø 10 mm, M8x1,25	Asta: Ø 8 mm; Tubo: Ø 18 mm	JOHN DEERE - FIAT - MASSEY FERGUSON	1180/DT, 1880/DT, 580/ DT, 680/DT, 780/DT, 980/DT	9933355, AL 33170, 3384671M1	
05396	350 mm	780 mm	150 N	Terminali: M8x1,25	Asta: Ø 8 mm; Tubo: Ø 18 mm	JOHN DEERE - MASSEY FERGUSON		3389556 M1, 3389556M1	
05398	90 mm	255 mm	300 N	Terminali: M8x1,25	Asta: Ø 8 mm; Tubo: Ø 18 mm	LANDINI - MASSEY FERGUSON	PORTIERA/DOOR 16500, PORTIERA/DOOR 3050, PORTIERA/DOOR 3060, PORTIERA/DOOR 3065, PORTIERA/DOOR 3070, PORTIERA/DOOR 3080, PORTIERA/DOOR 3090, PORTIERA/DOOR 3610, PORTIERA/DOOR 3630, PORTIERA/DOOR 3650, PORTIERA/DOOR 3680	3385316M91	
05397	65 mm	210 mm	180 N	Terminale asta: M6x1; terminale tubo	Asta: Ø 8 mm; Tubo: Ø 18 mm	LANDINI, MASSEY FERGUSON	TETTUCCIO/ROOF 16500, TETTUCCIO/ROOF 3050, TETTUCCIO/ROOF 3060, TETTUCCIO/ROOF 3065, TETTUCCIO/ROOF 3070, TETTUCCIO/ROOF 3080, TETTUCCIO/ROOF 3090, TETTUCCIO/ROOF 3610, TETTUCCIO/ROOF 3630, TETTUCCIO/ROOF 3650, TETTUCCIO/ROOF 3680	1897726M91, 3303021M91, 3303021M92	

MOLLE A GAS



RESSORTS A GAZ

GAS SPRINGS

GASDRUCKFEDERN

RESORTES A GAS

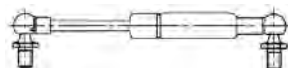
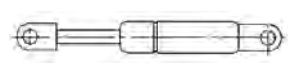

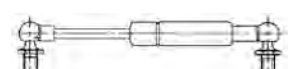
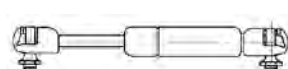
Art./Ref.	Corsa/ Stroke	Lunghezza bracci max mm/Max arm lenght mm	New- ton/ Newton	Attacco/Connection	Ø braccio/Ø arm	Note/Note	Brand	Rif. Orig./ Orig. Ref.	Disegno/Drawing
05399	215 mm	520 mm	350 N	Sfera Ø 10 mm, M8x1,25	Asta: Ø 8 mm; Tubo: Ø 18 mm	Per portiera/For door	SAME	9208.140.3	
05400	210 mm	515 mm	360 N	Sfera Ø 10 mm, M8x1,25	Asta: Ø 8 mm; Tubo: Ø 18 mm	Per portiera/For door		9241.140.4	
05401	215 mm	520 mm	170 N	Sfera Ø 10 mm, M8x1,25	Asta: Ø 8 mm; Tubo: Ø 18 mm	Per vetri/For windows		9233.166.4	
05402	215 mm	520 mm	270 N	Sfera Ø 10 mm, M8x1,25	Asta: Ø 8 mm; Tubo: Ø 18 mm	Per vetri/For windows		9233.167.4	
05403	225 mm	715 mm	350 N	Sfera Ø 10 mm, M8x1,25	Asta: Ø 8 mm; Tubo: Ø 18 mm	Per vetri/For windows		007.5407.0	
05404	140 mm	390 mm	570 N	Sfera Ø 10 mm, M8x1,25	Asta: Ø 8 mm; Tubo: Ø 18 mm	Per vetri/For windows		008.2089.4120	
05405	115 mm	330 mm	110 N	Terminale asta: sfera Ø 10 mm, M8x1,25; Terminale tubo: Ø foro 8,2 mm	Asta: Ø 8 mm; Tubo: Ø 18 mm	Per TETTuccio e VETRI / For ROOF e WINDOWS	SAME	9234.373.4	
05406	90 mm	260 mm	250 N	Terminali: Ø foro 8,2 mm	Asta: Ø 8 mm; Tubo: Ø 18 mm	Per tettuccio/For roof		9206.194.4	
09222	250 mm	585 mm	100 N	Sfera in plastica Ø 10 mm, M8x1,25	Asta: Ø 8 mm; Tubo: Ø 18 mm	Per Trattori serie 80 con cabina - vetro anteriore/ For Tractor series 80 with SK2 cabin - front window	STEYR	99-976-047	
09223	95 mm	275 mm	100 N	Sfera in plastica Ø 10 mm, M8x1,25	Asta: Ø 8 mm; Tubo: Ø 18 mm	Per Trattori serie 80 - tettuccio/For Tractor series 80 - roof		99-976-036	

MOLLE A GAS A MISURA

RESSORTS A GAS SUIVANT PLAN

CUSTOMISED GAS STRUTS

GASDRUCKFEDERN(NACH MASS)

MUELLES A GAS A MEDIDA



Art./Ref.	Corsa/ Stroke	Lunghezza bracci max mm/ Max arm lenght mm	Newton/ Newton	Attacco/Connection	Ø braccio/Ø arm	Disegno/Drawing
36381	109 mm	300 mm	200 N	Terminale asta: foro Ø 8,1 mm ; Terminale tubo: sfera in plastica Ø 10 mm, M8x1,25	Asta: Ø 8 mm; Tubo: Ø 18 mm	
36382	109 mm	300 mm	350 N	Terminale asta: foro Ø 8,1 mm ; Terminale tubo: sfera in plastica Ø 10 mm, M8x1,25	Asta: Ø 8 mm; Tubo: Ø 18 mm	
36383	134 mm	350 mm	200 N	Terminale asta: foro Ø 8,1 mm ; Terminale tubo: sfera in plastica Ø 10 mm, M8x1,25	Asta: Ø 8 mm; Tubo: Ø 18 mm	
36384	134 mm	350 mm	350 N	Terminale asta: foro Ø 8,1 mm ; Terminale tubo: sfera in plastica Ø 10 mm, M8x1,25	Asta: Ø 8 mm; Tubo: Ø 18 mm	
36385	164 mm	410 mm	200 N	Terminale asta: foro Ø 8,1 mm ; Terminale tubo: sfera in plastica Ø 10 mm, M8x1,25	Asta: Ø 8 mm; Tubo: Ø 18 mm	
36386	164 mm	410 mm	350 N	Terminale asta: foro Ø 8,1 mm ; Terminale tubo: sfera in plastica Ø 10 mm, M8x1,25	Asta: Ø 8 mm; Tubo: Ø 18 mm	
36387	184 mm	450 mm	200 N	Terminale asta: foro Ø 8,1 mm ; Terminale tubo: sfera in plastica Ø 10 mm, M8x1,25	Asta: Ø 8 mm; Tubo: Ø 18 mm	
36388	184 mm	450 mm	350 N	Terminale asta: foro Ø 8,1 mm ; Terminale tubo: sfera in plastica Ø 10 mm, M8x1,25	Asta: Ø 8 mm; Tubo: Ø 18 mm	
36389	214 mm	510 mm	200 N	Terminale asta: foro Ø 8,1 mm ; Terminale tubo: sfera in plastica Ø 10 mm, M8x1,25	Asta: Ø 8 mm; Tubo: Ø 18 mm	
36390	214 mm	510 mm	350 N	Terminale asta: foro Ø 8,1 mm ; Terminale tubo: sfera in plastica Ø 10 mm, M8x1,25	Asta: Ø 8 mm; Tubo: Ø 18 mm	

Art./Ref.	Corsa/ Stroke	Lunghezza bracci max mm/ Max arm length mm	Newton/ Newton	Attacco/Connection	Ø braccio/Ø arm	Disegno/Drawing
36391	234 mm	550 mm	200 N	Terminale asta: foro Ø 8,1 mm ; Terminale tubo: sfera in plastica Ø 10 mm, M8x1,25	Asta: Ø 8 mm; Tubo: Ø 18 mm	
36392	234 mm	550 mm	350 N	Terminale asta: foro Ø 8,1 mm ; Terminale tubo: sfera in plastica Ø 10 mm, M8x1,25	Asta: Ø 8 mm; Tubo: Ø 18 mm	
36393	264 mm	610 mm	200 N	Terminale asta: foro Ø 8,1 mm ; Terminale tubo: sfera in plastica Ø 10 mm, M8x1,25	Asta: Ø 8 mm; Tubo: Ø 18 mm	
36394	264 mm	610 mm	350 N	Terminale asta: foro Ø 8,1 mm ; Terminale tubo: sfera in plastica Ø 10 mm, M8x1,25	Asta: Ø 8 mm; Tubo: Ø 18 mm	
36395	264 mm	610 mm	450 N	Terminale asta: foro Ø 8,1 mm ; Terminale tubo: sfera in plastica Ø 10 mm, M8x1,25	Asta: Ø 8 mm; Tubo: Ø 18 mm	
36396	264 mm	610 mm	500 N	Terminale asta: foro Ø 8,1 mm ; Terminale tubo: sfera in plastica Ø 10 mm, M8x1,25	Asta: Ø 8 mm; Tubo: Ø 18 mm	
36397	264 mm	610 mm	700 N	Terminale asta: foro Ø 8,1 mm ; Terminale tubo: sfera in plastica Ø 10 mm, M8x1,25	Asta: Ø 8 mm; Tubo: Ø 18 mm	
36398	284 mm	650 mm	200 N	Terminale asta: foro Ø 8,1 mm ; Terminale tubo: sfera in plastica Ø 10 mm, M8x1,25	Asta: Ø 8 mm; Tubo: Ø 18 mm	
36399	284 mm	650 mm	350 N	Terminale asta: foro Ø 8,1 mm ; Terminale tubo: sfera in plastica Ø 10 mm, M8x1,25	Asta: Ø 8 mm; Tubo: Ø 18 mm	
36403	309 mm	700 mm	200 N	Terminale asta: foro Ø 8,1 mm ; Terminale tubo: sfera in plastica Ø 10 mm, M8x1,25	Asta: Ø 8 mm; Tubo: Ø 18 mm	
36404	309 mm	700 mm	350 N	Terminale asta: foro Ø 8,1 mm ; Terminale tubo: sfera in plastica Ø 10 mm, M8x1,25	Asta: Ø 8 mm; Tubo: Ø 18 mm	
36406	309 mm	700 mm	500 N	Terminale asta: foro Ø 8,1 mm ; Terminale tubo: sfera in plastica Ø 10 mm, M8x1,25	Asta: Ø 8 mm; Tubo: Ø 18 mm	
36407	309 mm	700 mm	700 N	Terminale asta: foro Ø 8,1 mm ; Terminale tubo: sfera in plastica Ø 10 mm, M8x1,25	Asta: Ø 8 mm; Tubo: Ø 18 mm	

TERMINALI PER MOLLA A GAS

PARTIE AVEC VIS POUR RESSORT GAS
 CLIP FOR GAS SPRING
 KONTAKT MIT SCHRAUBE FÜR GASFEDER
 TERMINAL CON TORNILLO PARA MUELLE GAS



Art./Ref.	Specifiche/Specifications
58562	Con vite
58563	Con occhiello

RETROVISORE COMPLETO CON ASTA TELESCOPICA

RETROVISEUR COMPLET AVEC BRAS REGLABLE
 REAR-VIEW MIRROR COMPLETE WITH TELESCOPIC SHAFT
 RÜCKBLICK SPIEGEL KOMPLETT MIT TELESKOPISCHER STANGE
 ESPEJO RETROVISOR COMPLETO CON VARILLA TELESCÓPICA

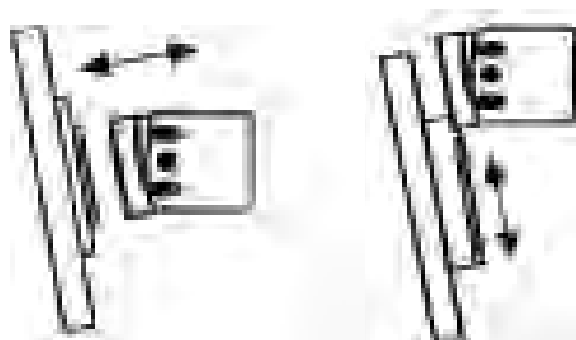
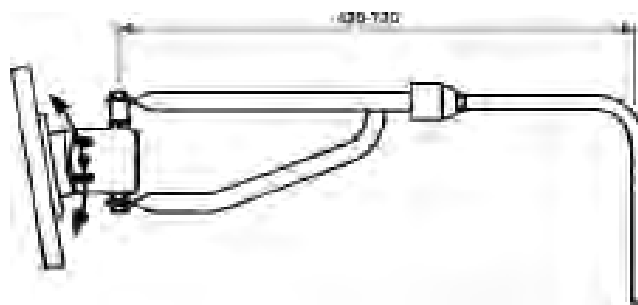

Note: Art. 34531: Coppa
 Art. 00743: Piastra fissa per asta telescopica
 Art. 00744: Piastra sfilabile per asta telescopica

Notes: Pn 34531: Rear view mirror spare part
 Pn 00743: Fixed plate for telescopic rod
 Pn 00744: Removable plate for telescopic rod

Art./Ref.	Descrizione/Description	Lunghezza mm/Lenght mm	Ø braccio/Ø arm	Specifiche/Specifications	Attacco/Connection
00741	Dx - sx	Asta telescopica: 443-709 mm	20 mm	Coppa: 230x180 mm	Vite M8x21mm

SPECCHI RETROVISORI PER TRATTORI

RETROVISEUR POUR TRACTEUR
TRACTOR REAR VIEW MIRROR
SCHLEPPERRÜCKSPIEGEL
ESPEJOS RETROVISOR PARA TRACTOR



Note: Art. 00742: Coppa
Art. 57828: Braccio dx
Art. 57829: Braccio sx

Notes: Pn. 00742: Mirror head
Pn 57828: Right arm
Pn.57829: Left arm

Art./Ref.	Attacco/Connection	Lunghezza mm/Lenght mm	Ø braccio/Ø arm	Specifiche/Specifications	Descrizione/Description
03746	Dx	240 mm	18 mm	Coppa 230x180 mm	Specchio con vetro curvo e regolazione manuale
03747	Sx	240 mm	18 mm	Coppa 230x180mm	Specchio con vetro curvo e regolazione manuale

SPECCHIO RETROVISORE PER TRATTORI

RETROVISEUR POUR TRACTEUR
TRACTOR REAR VIEW MIRROR
SCHLEPPERRÜCKSPIEGEL
ESPEJOS RETROVISOR PARA TRACTOR



Note: Art. 00742: Coppa
Art. 57826: Braccio dx
Art. 57827: Braccio sx

Notes: Pn. 00742: Head mirror
Pn. 57826: Right arm
Pn 57827: Left arm

Art./Ref.	Attacco/Connection	Lunghezza mm/Lenght mm	Ø braccio/Ø arm	Specifiche/Specifications	Descrizione/Description
27125	Dx	210 mm	18 mm	Coppa 230x180 mm	Specchio con vetro curvo e regolazione manuale
27126	Sx	210 mm	18 mm	Coppa 230x180 mm	Specchio con vetro curvo e regolazione manuale

SPECCHIO RETROVISORE

RETROVISEURS
TRACTOR REAR VIEW MIRROR
RÜCKSPIEGEL
ESPEJOS RETROVISORES



Note: Art. 34531: coppa
Art. 57798: braccio sx
Art. 57799: braccio dx

Notes: Pn 34531: Rear view mirror spare part
Pn 57798: Left arm
Pn 57799: Right arm

Art./Ref.	Attacco/Connection	Lunghezza mm/Lenght mm	Ø braccio/Ø arm	Specifiche/Specifications	Note/Note	Brand	Rif. Orig./Orig. Ref.
03116	Dx	250 mm	20 mm	Coppa: 230x180 mm	Vetro curvo / Rounded glass Vetro argentato / Silvered glass Regolazione manuale / Manual adjustment	FIAT	101735, 5108721, 6541132
03117	Sx	250 mm	20 mm	Coppa 230x180 mm	Vetro curvo / Rounded glass Vetro argentato / Silvered glass Regolazione manuale / Manual adjustment/	FIAT	101736, 5108722, 6541142

SPECCHIO RETROVISORE PER TRATTORI

RETROVISEUR POUR TRACTEUR
TRACTOR REAR VIEW MIRROR
SCHLEPPERRÜCKSPIEGEL
ESPEJOS RETROVISOR PARA TRACTOR



Note: Art. 03114: Coppa **Notes:** Pn 03114: Mirror head

Art./Ref.	Attacco/Connection	Lunghezza mm/Lenght mm	Ø braccio/Ø arm	Specifiche/Specifications	Descrizione/Description
03112	Dx	240 mm	18 mm	Coppa 235x140 mm	Specchio con vetro curvo e regolazione manuale
03113	Sx	240 mm	18 mm	Coppa 235x140 mm	Specchio con vetro curvo e regolazione manuale

SPECCHI RETROVISORI ADATTABILI A TRATTORI FIAT

RETROVISEUR POUR TRACTEUR
FIAT TRACTOR REAR VIEW MIRROR
SCHLEPPERRÜCKSPIEGEL
ESPEJOS RETROVISOR PARA TRACTOR



Note: Art. 34607: Coppa **Notes:** Pn 34607: Head mirror

Art./Ref.	Attacco/Connection	Lunghezza mm/Lenght mm	Ø braccio/Ø arm	Specifiche/Specifications	Brand	Applicazione/Application	Rif. Orig./Orig. Ref.
19064	Dx	210 mm	18 mm	Coppa 235x180 mm	FIAT	TN 90F, TN55V, TN65F, TN65N, TN65V, TN70F, TN75F, TN75N, TN75V, TN80F, TN95F	5177581, 5194637
34609	Sx	210 mm	18 mm	Coppa 235x180 mm	FIAT	TN 90F, TN55V, TN65F, TN65N, TN65V, TN70F, TN75F, TN75N, TN75V, TN80F, TN95F	5177582, 5194636

SPECCHI RETROVISORI

RETROVISEURS
REAR VIEW MIRRORS
RÜCKSPIEGEL
ESPEJOS RETROVISORES



Note: Art. 03122: Coppa **Notes:** Pn 03122: Mirror head

Art./Ref.	Attacco/Connection	Lunghezza mm/Lenght mm	Ø braccio/Ø arm	Specifiche/Specifications	Descrizione/Description	Brand	Applicazione/Application
03118	Dx	270 mm	18 mm	Coppa: 346x162 mm	Vetro curvo Vetro argentato Regolazione manuale	DEUTZ - FIAT - SOVEMA	90M5.3, 100F13, 50NC, 65F10, 70F10, 80NC, 90NC, F10, F13, F9, OM 100, OM 55, OM 60, OM 65, OM 70, OM 75, OM 80, OM 90, OM50, CABINE
03119	Sx	270 mm	18 mm	Coppa 346x162 mm	Vetro curvo Vetro argentato Regolazione manuale	DEUTZ - FIAT - SOVEMA	90M5.3, 100F13, 50NC, 65F10, 70F10, 80NC, 90NC, F10, F13, F9, OM 100, OM 55, OM 60, OM 65, OM 70, OM 75, OM 80, OM 90, OM50, CABINE

SPECCHI RETROVISORI

RETROVISEURS

REAR VIEW MIRRORS

RÜCKSPIEGEL

ESPEJOS RETROVISORES

**Note:** Per macchinario ortofrutticolo**Art. 60291:** Coppa**Notes:** For fruit end vegetable machinery**Pn 60291:** Mirror head

Art./Ref.	Attacco/Connection	Ø braccio/Ø arm	Specifiche/Specifications
58564	Dx	20 mm	Coppa 160x250 mm
58565	Sx	22 mm	Coppa 160x250 mm

RICAMBI PER SPECCHI RETROVISORI

RECHANGES POUR RETROVISEURS

REAR VIEW MIRRORS SPARE PARTS

RÜCKSPIEGEL ERSATZTEILE

RECAMBIOS ESPEJOS RETROVISORES



Art./Ref.	Specifiche/Specifications	Attacco/Connection	Brand	Applicazione/Application	Rif. Orig./Orig. Ref.
03122	344x163 mm	20 mm	DEUTZ - SIAC - ITALCAB - FIAT - A.M.A.	03118, 90M5.3, 100F13, 50NC, 6FS10, 70F10, 80NC, 90NC, F10, F13, F9, OM 100, OM 50, OM 55, OM 60, OM 65, OM 70, OM 75, OM 80, OM 90, CABINE, CABINE	4697662
03123	359x209 mm	20 mm	MERLO - ITALCAB - FIAT - A.M.A.	03119, 130NC, 150N520, 159NC20, 170/NT35, 190/F35T, 682N4, OM 110, OM 150/20, OM 190/35, OM170/35, CABINE	4723931, 5165633, 042848
76424	295x215 mm	16 - 18 - 20 mm	JOHN DEERE	6000, 6010, 6100, 6110, 6120, 6200, 6205, 6210, 6220, 6300, 6310, 6320, 6400, 6410, 6420, 6505, 6510, 6520, 6600, 6610, 6620, 6800, 6810, 6820, 6900, 6910, 6920, 7200, 7400, 7600, 7610, 7700, 7710, 7800, 7810, 8100, 8110, 8120, 8200, 8210, 8220, 8300, 8310, 8320, 8400, 8420, 8520, 8570, 8770, 8870, 8970	AL78021

COPPA A RICAMBIO

RETROVISEUR

HEAD MIRROR

RÜCKSPIEGEL ERSATZTEILE

RECAMBIOS ESPEJOS RETROVISORES



Art./Ref.	Specifiche/Specifications	Attacco/Connection	Brand	Applicazione/Application	Rif. Orig./Orig. Ref.
34531	230x180 mm	20 mm	MERLO - LANDINI - DEUTZ - FIAT - CASE IH - A.M.A. - STEYER - SAME - RENAULT - MASSEY FERGUSON	03116, 03117	5126233, 71408392, 9975396, D.9233.183.3, 5126233, 9958752, 3557565M91, 3557565M91, 032887, 6005022753, 0.9233.183.3, 5126233, 71408392, 9968878

COPPA A RICAMBIO

RETROVISEUR
HEAD MIRROR
RÜCKSPIEGEL ERSATZTEILE
RECAMBIOS ESPEJOS RETROVISORES

Art./Ref.	Specifiche/ Specifications	Attacco/ Connection	Brand	Applicazione/Applic- ation	Rif. Orig./ Orig. Ref.
00742	230X180 mm	18 mm	FIAT - A.M.A.	00741, 03746, 03747, 27125, 27126	5126233, 9958752

COPPA A RICAMBIO

RETROVISEUR
HEAD MIRROR
RÜCKSPIEGEL ERSATZTEILE
RECAMBIOS ESPEJOS RETROVISORES

Art./Ref.	Specifiche/ Specifications	Attacco/ Connection	Brand	Applicazione/ Application
03114	235X140 mm	18 mm	A.M.A.	03112, 03113

COPPA A RICAMBIO

RECHANGES POUR RETROVISEURS
REAR VIEW MIRRORS SPARE PARTS
RÜCKSPIEGEL ERSATZTEILE
RECAMBIOS ESPEJOS RETROVISORES

Art./Ref.	Specifiche/ Specifications	Attacco/ Connection	Brand	Applicazione/ Application	Rif. Orig./ Orig. Ref.
34607	235x180 mm	18 mm	FIAT - A.M.A.	19064, 34609, TN 90F, TN55V, TN65F, TN65N, TN65V, TN70F, TN75F, TN75N, TN75V, TN80F, TN95F	5126233, 5186849

COPPA A RICAMBIO

RETROVISEUR
MIRROR HEAD
RÜCKSPIEGEL ERSATZTEILE
RECAMBIOS ESPEJOS RETROVISORES

Art./Ref.	Specifiche/ Specifications	Attacco/ Connection	Brand	Applicazione/ Application	Rif. Orig./Orig. Ref.
60291	250X160 mm	20 mm	CARRARO-AGRITALIA - CASE IH - A.M.A. - RENAULT - BOBCAT	58564, 58565	147404061, 047966, 1344062C1, 001130811, 6005022753



1.8.17 Alternatori e Regolatori

Regulator and alternator



Ricambi & accessori per macchine agricole
SPARE PARTS & ACCESSORIES FOR AGRICULTURAL MACHINE

Tutti gli articoli della presente sezione, prodotti da AMA SPA e/o da terzi per conto di AMA, sono adattabili ("non originali") alle marche indicate ai sensi di quanto previsto dal REG. CE n. 1400/2002. I diritti sui marchi citati appartengono ai legittimi proprietari ed il loro uso ha l'esclusiva finalità di consentire all'utilizzatore la comparazione dei diversi prodotti. All items of this section, manufactured by AMA SPA and/or any third party on behalf of AMA, are adaptable ("non-original") to the brands listed under the provisions of the REG. CE n. 1400/2002. The rights on the trademarks belong to their respective owners and their usage is only aimed to allow the user to compare different products.

ALTERNATORI VOLANO

ALTERNATEURS
ALTERNATORS
ALTERNATOREN
ALTERNADORES



Art./Ref.	Watt/Watt	Note/Note
01456	180W - 12V	Luce (2 fari) con batteria/Light (2 lamps) with battery

CONNETTORE PER REGOLATORE

MORCEAU POUR REG.60288-60289
CONNECTOR
BANDSCHELLE F/60288 UND 60289
CONNETTORE PER REGOLATORE



Art./Ref.	Note/Note
60290	Per regolatori di tensione Saprisa 7155 e 7255 (art. AMA 60289)/For voltage regulator: Saprisa 7155 e 7255 (Pn. AMA 60289)

RICAMBI ACCENSIONE

PIECES DEMARRAGES
IGNITION SPARES
ZÜNDUNG ERSATZTEI
REPUESTOS ARRANQUE



Art./Ref.	Pos.	Tipo/Type	Brand	Applicazione/Application	Rif. Orig./Orig. Ref.
00558	1	Contatto/Contact	ACME	AL65, AL70, AL75, FE82, VT88	1002, 101.300, 717.101.300
00768	1	Contatto/Contact	COTIEMME - ACME	AL215, AL290, AL330, CA150, CA250, CA295, CA340, CA350, CA450, CA550	005.300, 3186, 711.005.300, 5/3319.00
00560	1	Contatto/Contact	MARELLI - COTIEMME - LOMBARDINI	MCR 12, LA60, LA65, LA80, LA90, MCR 12, MCR 12	718.097.01
01298	1	Contatto/Contact	LOMBARDINI - INTERMOTOR		70.5040.06, 70.5040.06/5, 70.51180, 70.5040.06, 70.5040.06/5, 70.51180
01289	2	Condensatore/Condenser	ACME	AL65, AL70, AL75, FE82, VT88	1498
03450	2	Condensatore/Condenser	COTIEMME - ACME	AL215, AL290, AL330, CA150, CA250, CA295, CA340, CA350, CA450, CA550	1498/10, 372337.00
01297	2	Condensatore/Condenser	LOMBARDINI	-	70.2522.10, 70.74.02

1.8.18 Colonnette

Steering columns



Ricambi & accessori per macchine agricole

SPARE PARTS & ACCESSORIES FOR AGRICULTURAL MACHINE

Tutti gli articoli della presente sezione, prodotti da AMA SPA e/o da terzi per conto di AMA, sono adattabili ("non originali") alle marche indicate ai sensi di quanto previsto dal REG. CE n. 1400/2002. I diritti sui marchi citati appartengono ai legittimi proprietari ed il loro uso ha l'esclusiva finalità di consentire all'utilizzatore la comparazione dei diversi prodotti. All items of this section, manufactured by AMA SPA and/or any third party on behalf of AMA, are adaptable ("non-original") to the brands listed under the provisions of the REG. CE n. 1400/2002. The rights on the trademarks belong to their respective owners and their usage is only aimed to allow the user to compare different products.

CL 2000 LUNGA

CL.2000 LONG

CL.2000 LONG VERSION

CL.2000 LONG

CL.2000 LARGO

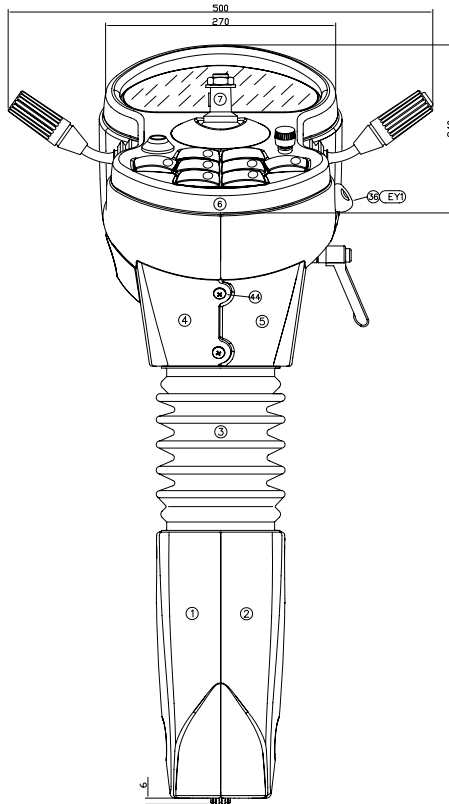

POSITION	CODE	DESCRIPTION	POSITION	CODE	DESCRIPTION
1	DIS.2070	LEFT FOOT OF COLUMN	31	F32010	NUT UN2473 M4 65 ZB
2	DIS.2071	RIGHT FOOT OF COLUMN	32	0012162	SPEED SWITCH
3	DIS.1099	BELLOWS	33	0012160	LIGHT SWITCH
4	DIS.2076	LEFT SIDE OF THE COLUMN	34	F32126	SCREW TCE1 UN25X38 M5X38 8.8 ZB
5	DIS.2118	RIGHT SIDE OF THE COLUMN	35	DIS.2235-01	BRACKET
6	DIS.2113	FRONT COLUMN	36	013062	START ENGINE KEY
7	041.000.464	GROUP TLT	37	135066	CAP 8 ZB
8	S14151	GENERATOR WARNING LIGHT	38	F17047.4	COVER FUSE BOX
9	S14152	OIL PRESSURE WARNING LIGHT	39	F32121	SCREW TCB T1/2X12 M5X8 4.8 ZN
10	S14153	WATER TEMPERATURE WARNING LIGHT	40	F17003	FUSE 4 AMP
11	S14154	OIL FILTER WARNING LIGHT	41	F17005	FUSE 7.5 AMP
12	S14155	AIR FILTER WARNING LIGHT	42	F17006	FUSE 10 AMP
13	S14156	PARKING WARNING LIGHT	43	F17007	FUSE 15 AMP
14	S14157	FUEL WARNING LIGHT	44	F32147	SCREW M5X6 1.4X5 ZN
15	S14158	GLOW PLUG WARNING LIGHT	45	F32148	SCREW M5X6 8.8 ZN
16	S14161	DIRECTION LIGHTS WARNING LIGHT	46	F32165	SCREW TCB T1/2X12 M5X8 ZN
17	S14162	SEDLIGHTS WARNING LIGHT	47	DIS.1548	STOKEE LIGHT
18	S14163	LOW BEAM WARNING LIGHT	48	115134	ROKER SWITCH LIGHT
19	S14165	HIGH BEAM WARNING LIGHT	49	136006	EMERGENCY SWITCH
20	S14168	OIL PRESSURE WARNING LIGHT	50	137721	CAP ROKER SWITCH
21	S14170	NEUTRAL WARNING LIGHT	51	137701	ROKER SWITCH CAP
22	S14179	BRAKE WARNING LIGHT	52	137724	ROKER SWITCH CAP
23	S14188	OIL TEMPERATURE WARNING LIGHT	53	137719	ROKER SWITCH CAP
24	L26049	LAMP FOR INDICATOR 12V	54	137707	ROKER SWITCH CAP
25	IMEL.053.1	HARNES	55	137731	ROKER SWITCH CAP
26	ATS21001	INSTRUMENT TACH HOURMETERS	56	137715	ROKER SWITCH CAP
27	S21002P-12V	INSTRUMENT FUEL LEVEL	57	137733	ROKER SWITCH CAP
28	S21062P-12V	INSTRUMENT WATER TEMPERATUR	58	137003	ROKER SWITCH
29	DIS.2303	INSTRUMENT PANEL	59	137007	ROKER SWITCH
30	DIS.1739	BRACKET PANEL	60	137050	ROKER SWITCH

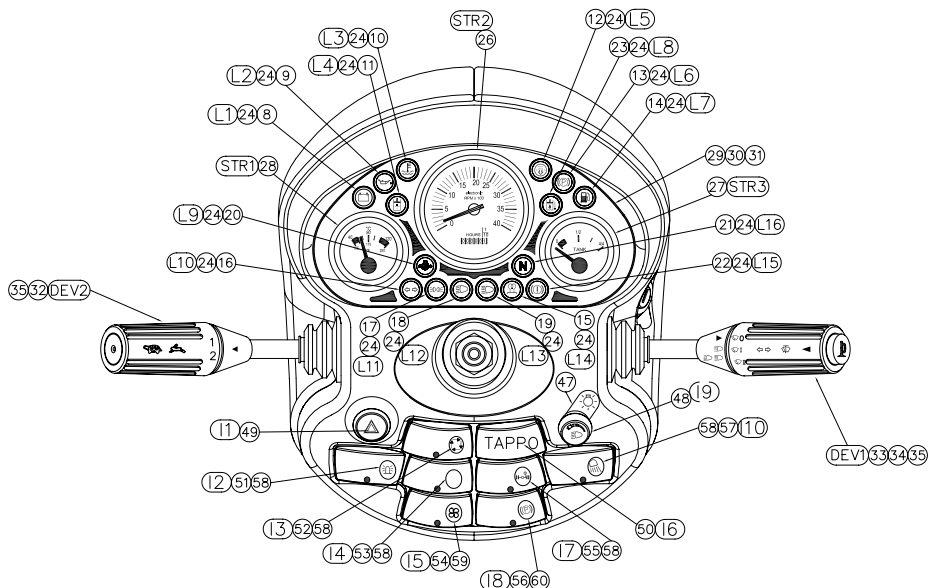
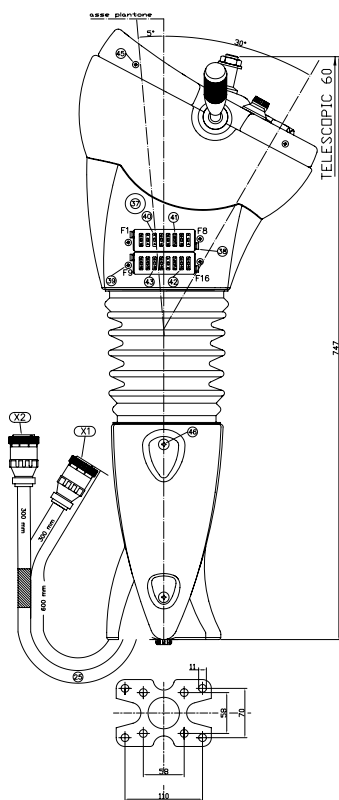

Art./Ref.	Note/Note	Volt/Volt	Materiale/Material	Colore/Color	Regolazione/Regolazione	Volante/Volante	Cablaggio/Cablaggio	Corredo/Corredo
IMEL.053	Altezza 747 mm	12V	ABS	Nero/Black	Manuale Telescopica 60 mm e inclinabile (30° verso operatore, 5° verso il vetro)	Volanete 360 Pomello serie 6	lunghezza 600 mm	Connettori controparte
IMEL.054	Altezza 747 mm	24V	ABS	Nero/Black	Manuale telescopica 60 mm e inclinabile (30° verso l'operatore, 5° verso il vetro)	Volante 360 con pomello serie 6	Lunghezza 600 mm	Connettori controparte

CL.2000 CORTA

- CL.2000 COURT
- CL.2000 SHORT VERSION
- CL.2000 SHORT
- CL.2000 CORTO

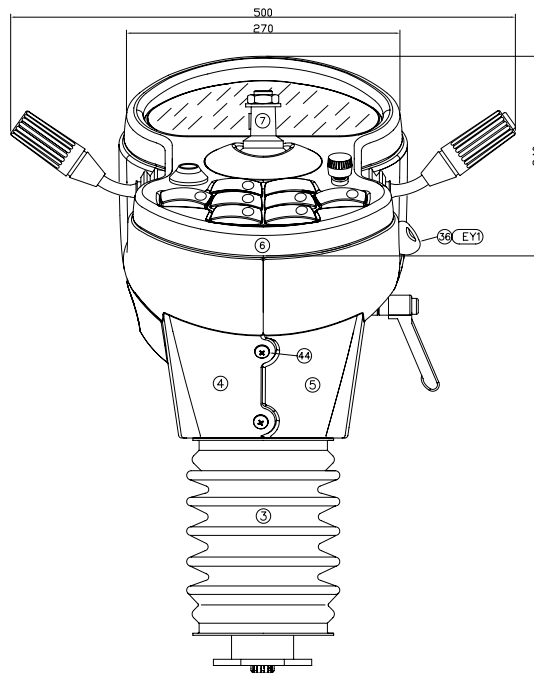

POSITION	CODE	DESCRIPTION	POSITION	CODE	DESCRIPTION
1	-----	-----	31	F30010	RAI (METHA) M4 G2 IN
2	-----	-----	32	002162	SPEED SWITCH
3	D01099	BELLRING	33	002260	LIGHT SWITCH
4	D010976	LEFT SIDE OF THE COLUMN	34	F30226	SOEVEY TEEZ UNDER MOSE 88 IN
5	D010918	RIGHT SIDE OF THE COLUMN	35	D012029-01	BRACKET
6	D012113	FRONT COLUMN	36	002062	START ENGINE KEY
7	041000495	GROUP FILT	37	130566	CAP IN IN
8	S14121	GENERATOR WARNING LIGHT	38	F17047.4	COVER FUSE BOX
9	S14120	OIL PRESSURE WARNING LIGHT	39	F30212	SOEVEY TEEZ FLUTE MOSE 48 IN
10	S14133	WATER TEMPERATURE WARNING LIGHT	40	F17003	FUSE 4 AMP
11	S14154	OIL FILTER WARNING LIGHT	41	F17005	FUSE 7.5 AMP
12	S14125	AIR FILTER WARNING LIGHT	42	F17006	FUSE 10 AMP
13	S14156	PARKING WARNING LIGHT	43	F17007	FUSE 15 AMP
14	S14157	FUEL WARNING LIGHT	44	F30147	SOEVEY MOSE 14x5 IN
15	S14158	GLW PLUG WARNING LIGHT	45	F30148	SOEVEY MOSE 88 IN
16	S14161	DIRECTION LIGHTS WARNING LIGHT	46	-----	-----
17	S14162	SIGNALS LIGHTS WARNING LIGHT	47	D011548	STEERER LIGHT
18	S14163	LOW BEAM WARNING LIGHT	48	135134	ROKER SWITCH LIGHT
19	S14165	HIGH BEAM WARNING LIGHT	49	136096	EMERGENCY SWITCH
20	S14168	OIL PRESSURE WARNING LIGHT	50	137721	CAP ROKER SWITCH
21	S14170	NEUTRAL WARNING LIGHT	51	137701	ROKER SWITCH CAP
22	S14179	BRAKE WARNING LIGHT	52	137724	ROKER SWITCH CAP
23	S14188	OIL TEMPERATURE WARNING LIGHT	53	137719	ROKER SWITCH CAP
24	L86649	LAMP FOR INDICATOR 2V	54	137707	ROKER SWITCH CAP
25	IMEL0531	HANDLES	55	137731	ROKER SWITCH CAP
26	A052100	INSTRUMENT HIGH HEADLIGHTS	56	137733	ROKER SWITCH CAP
27	S02060P-12V	INSTRUMENT FUEL LEVEL	57	137732	ROKER SWITCH CAP
28	S02060P-12V	INSTRUMENT WATER TEMPERATURE	58	137003	ROKER SWITCH
29	D012093	INSTRUMENT PANEL	59	137007	ROKER SWITCH
30	D011739	BRACKET PANEL	60	137000	ROKER SWITCH

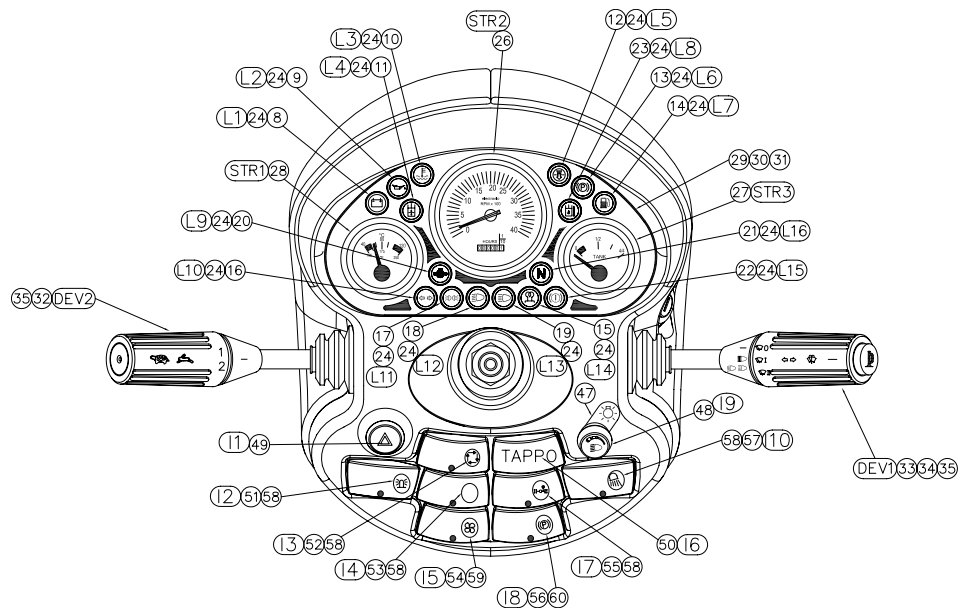
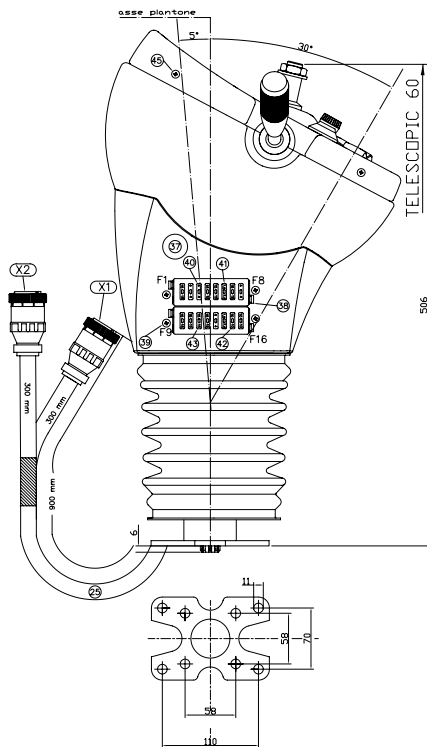

Art./Ref.	Note/Note	Volt/Volt	Materiale/Material	Colore/Color	Regolazione/Regolazione	Volante/Volante	Cablaggio/Cablaggio	Corredo/Corredo
IMEL.055	Altezza 506 mm	12V	ABS	Nero/Black	Manuale telescopica 60 mm e inclinabile (30° verso l'operatore, 5° verso il vetro)	Volante 360 con pomello serie 6	Lunghezza 600 mm	Connettori controparte
IMEL.056	Altezza 560 mm	24V	ABS	Nero/Black	Manuale telescopica 60 mm e inclinabile (30° verso l'operatore, 5° verso il vetro)	Volante 360 con pomello serie 6	Lunghezza 600 mm	Connettori controparte

