

BYTE

the small systems journal

AUGUST 1983 Vol. 8, No. 8
\$3.95 in Canada/£2.10 in U.K.
A McGraw-Hill Publication
0360-5280



The C Language

How to quickly re

If you'd like to turn the agony of small business bookkeeping into the ecstasy of total control, you've come to the right place.

Because even if you're starting with a shoe box full of invoices or a pile of checks hiding under a pile of deposit slips, we can tell you how to centralize, organize and monitor all that information, and manipulate it in ways that will make your business a

pleasure—all with an Apple® III Personal Computer.

Attain instant financial status.

An Apple III, teamed with the BPI General Accounting Package, can put every basic accounting function right at your fingertips.

Technically, that means

General Ledger, Accounts Payable, Accounts Receivable and Payroll—all in one package.

Meaningfully, that means you can turn numbers into answers.

With BPI, your Apple III can give you a snapshot of your company's financial condition,

an up-to-the-instant balance sheet. It

can also generate instant and detailed reports

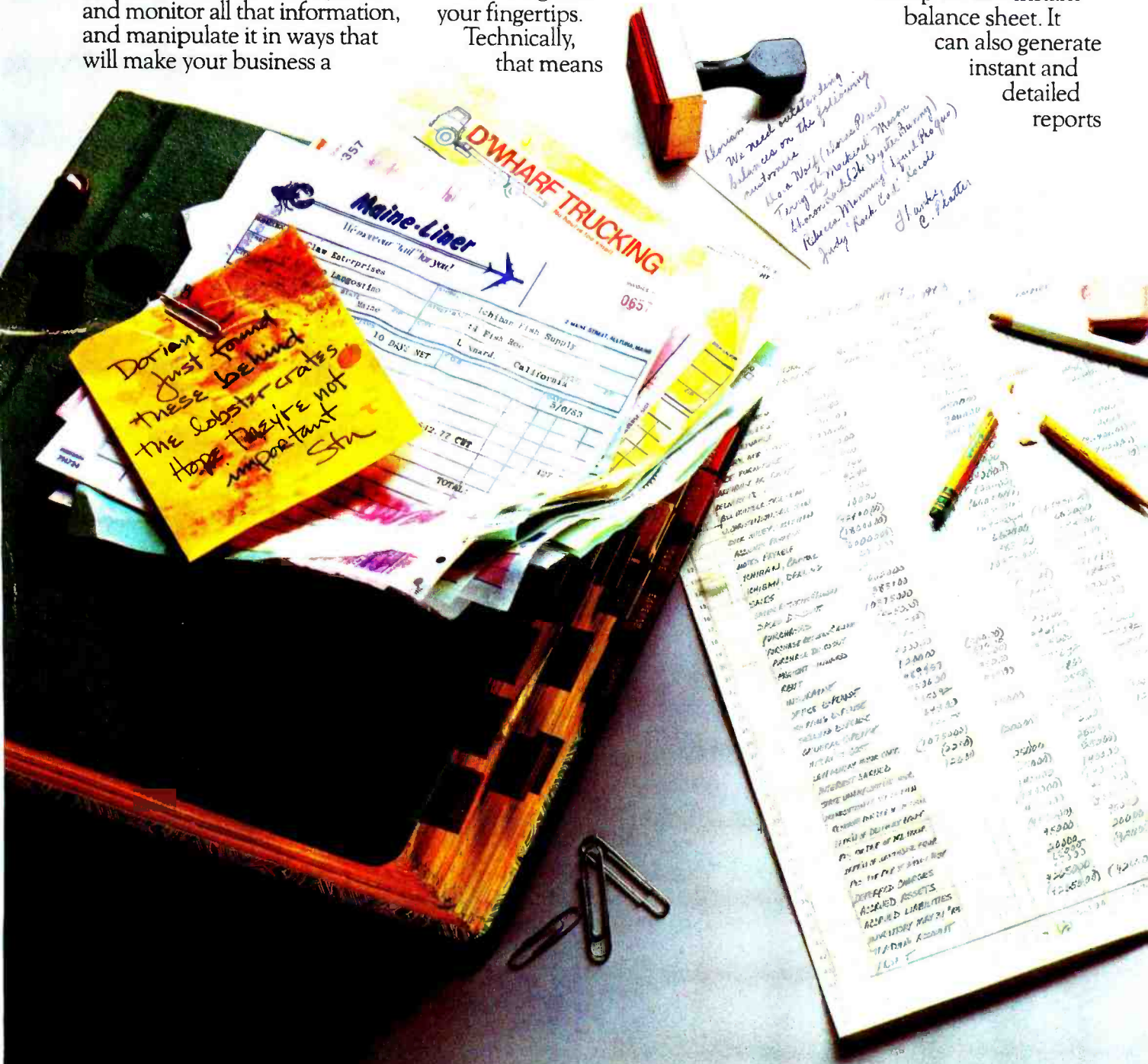

gain your balance.

on your customers and vendors.

So you know who owes whom, how much, and how come.

And just how well your cash flow is flowing.

And where to give credit where credit is due (a customer inquiry

The BPI General Accounting Package also lets your income statements be coded by location, department or product line. So you know where your money's coming from.

And where it's not.

results will make an important statement to everyone you deal with—including your banker.

More ways Apples pay.

There are more people in more places doing more things with

Ichiban Fish Supply Company Consolidated Income Statement Current Comparative Periods Ending May 31, 1983 and May 31, 1982				
	May 31, 1983	%	May 31, 1982	%
Income				
Contract Sales	52,818.82	91.3	44,126.52	92.7
Retail Sales	3,816.88	8.7	3,588.86	
Total Income	57,834.90	100.0	47,676.52	100.0
Cost of Sales				
Cost of Contract Sales	37,338.88	64.6	31,886.55	66.7
Cost of Retail Sales	4,879.85	8.4	3,489.35	7.2
Total Cost of Sales	42,288.95	73.0	35,215.98	73.9
Gross Profit	15,625.05	27.0	12,460.62	26.1

Your Apple can generate instant income statements (with expense ratios) or balance sheets, and let you compare them to last month's or year's, then print them out to suit your banker.

feature allows you to make credit decisions based on the most current information).

You can also list your purchases by discount dates. And take advantage of them in no uncertain net terms. You can even keep payroll records without paying more, because it's part of the same package.

Profit from history.

In business as in life, experience is the best teacher. And the Apple/BPI system can provide you with instant comparisons of this-month-this-year vs. this-month-last-year, or this-year-to-date vs. last-year-to-date.

So you can quickly spot changing expense ratios and make decisions with 20/20 foresight.

Ichiban Fish Supply Company Merchandise Purchased By Due (Date As Of 05/31/83)					
Date	Vendor No. Name	Invoice Number	Acct No.	Detail	Net Amt
05/02/83	1 Herring World Due 05/03/83	35278532	5010-01		501.23
05/05/83	2 Consolidated Cod Due 06/05/83	4562	5010-01		289.36
05/05/83	3 Lewy South Farm Due 06/05/83	212	5010-01		459.00
05/05/83	4 Russel Men. Inc Due 06/05/83	657	5010-01		68.26
	Total				1,277.85

It can also allow you to take full advantage of merchandise discounts. So you'll know whom to pay when to pay, how much to pay—and save a lot of clams in the process.

Make a timely statement.

Add an Apple Dot Matrix or Daisywheel printer to your Apple III, and you can print out your entire balance sheet in minutes.

Or any number of reports, from cash receipts to payroll ledger to income. You can even print checks and customer statements.

The impressively professional



Ichiban Fish Supply Company Accounts Receivable Ledger Page 1				
As of 05/31/83	Customer No. Name	Folio	Balance Forward	Current Month
	1 Moser's Sole Food		892.79	
	Invoice 1124	IR		212.23
	Invoice 1159	IR		138.36
	Invoice 1326	IR		542.00
	05/15/83	CR		250.00
				1,831.58

To avoid fishy transactions, you can instantly display customer's payments, charges and current balance. In this case, a few more cans of tuna would put Mr. Moser over his \$2,000 limit.

Apples than with any other personal computer in the world.

Because for one thing, there's more software for Apples than for any other personal computer in the world. So the same Apple that handles all your accounting needs can also handle financial spreadsheets, word processing and electronic filing.

You'll also find programs that are designed specifically for your kind of business. Be it dentistry, architecture or swine herding.

Of course, the best way to learn all the ways Apples can help you make better business decisions is to visit any one of over 1500 authorized Apple dealers.

So drop in. For a full account.



The most personal computer

Call (800) 538-9696 for the location of the authorized Apple dealer nearest you, or for information regarding our National Academic Program. Or write Apple Computer Inc., Advertising Department, 20525 Mariani Avenue, Cupertino, CA 95014. © 1983 Apple Computer, Inc.

Circle 28 on inquiry card.



Page 46

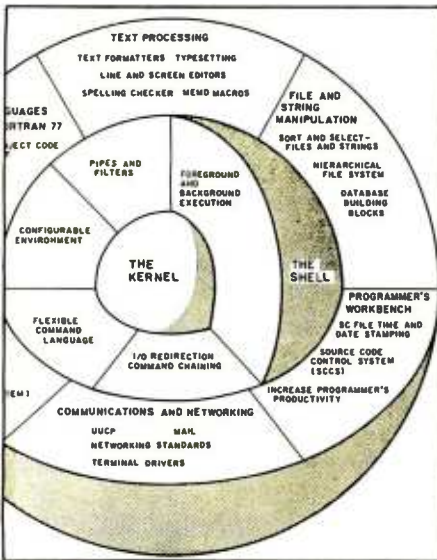

Page 186

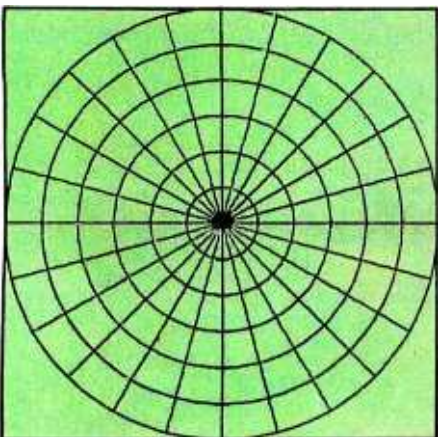

Page 386

Themes

46 The C Language by Bruce Roberts / Designed to make programs portable, fast, and compact, C is the language of choice for many programmers. This month's theme articles survey the reasons why.

48 The C Language and Models for Systems Programming by Stephen C. Johnson and Brian W. Kernighan / A happy medium between low- and high-level languages, C provides a model for efficient programming.

64 A C Language Primer, Part 1: Constructs and Conventions by James Joyce / A guided tour through C's keywords and functions.

82 Comparing C Compilers for CP/M-86 by Jerry Houston, Jim Brodrick, and Les Kent / A look at which compilers for CP/M-86 systems are best suited to particular purposes, most cost-effective, and easiest to use.

110 Five C Compilers for CP/M-80 by Christopher O. Kern / How C compilers for the CP/M-80 operating system stack up.

134 Nine C Compilers for the IBM PC by Ralph A. Phraner / A discriminating look at the C compilers available for this lucrative software market.

172 Managing Software Development with C by Jason Linhart / Choosing a good programming environment can affect programming ease and code quality more than you might imagine.

186 The Unix Tutorial, Part 1: An Introduction to Features and Facilities by David Fiedler / An overview of Bell Laboratories' Unix operating system and its toolbox of utilities.

212 A Survey of C and Unix Resources by Walter Zintz / A guide to materials, courses, and on-line instruction in C.

222 What Is a Software Tool? by Rebecca Thomas / How to use Unix and C to design programs that in turn will help you to design other programs.

243 The Unix C Compiler in a CP/M Environment by Matthew Halfant / A look at how compatible the standard C compiler is when it's used under CP/M.

268 Annotated C: A Bibliography of the C Language by Terry A. Ward / Where to find books, articles, and reviews on C.

Features

36 Build a Power-Line Carrier-Current Modem by Steve Ciarcia / Now your computer can communicate over electrical power wiring.

BYTE is published monthly by McGraw-Hill, Inc., with offices at 70 Main St. Peterborough NH 03458, phone (603) 924-9281. Office hours: Mon—Thur 8:30 AM — 4:30 PM. Friday 8:30 AM — Noon. Eastern Time. Address subscriptions, change of address, USPS Form 3579, and fulfillment questions to BYTE Subscriptions, POB 590, Martinsville NJ 08836. Second class postage paid at Peterborough, N.H. 03458 and additional mailing offices. USPS Publication No. 528890 (ISBN 0360-5280). Postage Paid at Winnipeg, Manitoba. Registration number 9321. Subscriptions are \$21 for one year, \$38 for two years, and \$55 for three years in the USA and its possessions. In Canada and Mexico, \$23 for one year, \$42 for two years, \$61 for three years, \$53 for one year air delivery

286 Chisel Your Code with a Profiler by Dennis Leas and Paul Wintz / Execute compiler programs at the rate of assembly-language programs, but at a fraction of the effort and cost.

292 A New Shape Subroutine for the Apple by Richard T. Simoni Jr. / A flicker-free animation scheme for the Apple II.

312 The Debate Goes On. . . by Jerry Pournelle / Jerry looks at programming languages, from APL to Modula-2.

331 The IBM PC and the Intel 8087 Coprocessor, Part 1: Overview and Floating-Point Assembly-Language Support by Tim Field / This software utility makes it easy to add powerful floating-point, integer, and BCD arithmetic operations from assembly language.

386 Curious Coordinates for Computer Graphics by Roger Millikan / Cartesian coordinates are not always the best choice for all plotting tasks.

401 BYTE West Coast: The Future of Software Design by William Gates / Microsoft's chairman of the board analyzes today's software issues and predicts the directions software will take tomorrow.

404 The 8086—An Architecture for the Future, Part 3: Instruction Set Continued by Stephen A. Heywood / In the last article of this series, the author discusses program transfers, string manipulations, and processor-control instructions.

434 User's Column: Epson QX-10, Zenith Z-29, CP/M-68K, and More by Jerry Pournelle / Our resident user reviews new products and answers some old mail.

456 Voice Lab, Part 2, Menu-Driven Routines for Digital Speech Synthesis and Analysis by John E. Hoot / Modular routines are well suited to speech synthesis and analysis.

477 Help In Apple III Pascal by Al Evans / Adding on-line instructions that will come to your aid anywhere in application software.

Nucleus

- | | |
|---|---------------------------|
| 4 Editorial: DEC, IBM, and Athena | 483 Books Received |
| 7 MICROBYTES | 484 Ask BYTE |
| 10 Letters | 490 Clubs and Newsletters |
| 378 Programming Quickie: A Cross-Reference Utility for IBM PC BASIC | 492 Software Received |
| 394 Technical Forum: A Gauss-Jordan Elimination Method Program | 495 Event Queue |
| 430 Book Reviews: CBASIC User Guide; An Assembly Language Course | 503 What's New? |
| | 572 Unclassified Ads |
| | 574 BOMB, BOMB Results |
| | 575 Reader Service |

Cover Painting by Robert Tinney

to Europe, 17,100 yen for one year surface delivery to Japan. \$37 surface delivery elsewhere. Air delivery to selected areas at additional rates upon request. Single copy price is \$3.50 in the USA and its possessions, \$3.95 in Canada and Mexico, \$4.50 in Europe, and \$5.00 elsewhere. Foreign subscriptions and sales should be remitted in United States funds drawn on a US bank. Printed in United States of America.

Subscription questions or problems should be addressed to:
BYTE Subscriber Service, P.O. Box 328, Hancock, NH 03449

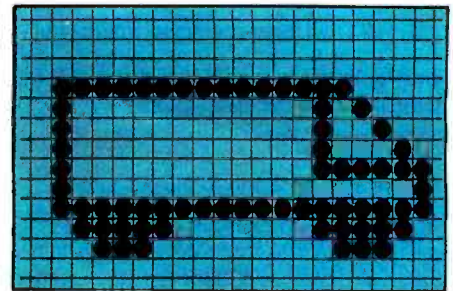

Page 292

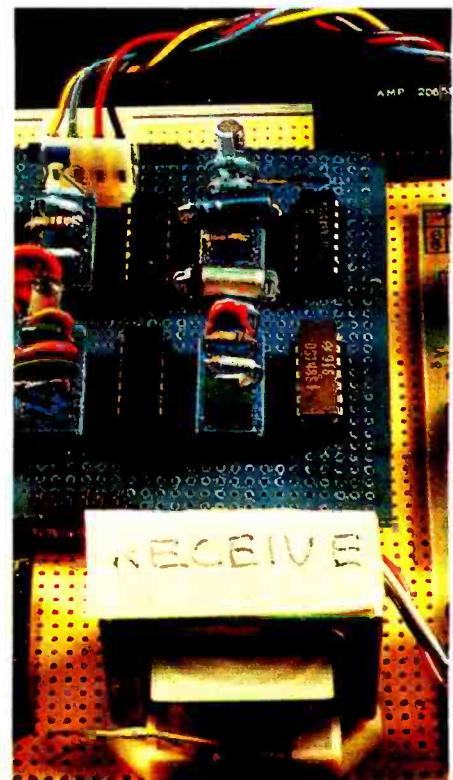

Page 36



Page 503

Editor In Chief: Lawrence J. Curran

Managing Editor: Pamela A. Clark

Senior Technical Editors: Gregg Williams,
Richard Malloy

Technical Editors: Richard S. Shuford, Curtis P. Feigel, Arthur A. Little, Stanley Wszola, Bruce Roberts, Mark Welch; Anthony J. Lockwood, New Products Editor; Steve Ciarcia, Consulting Editor; Alan Easton, Drafting Editor.

West Coast Editors: Philip Lemmons, Bureau Chief; Barbara Robertson, Technical Editor. McGraw-Hill, 425 Battery Street, 4th Floor, San Francisco, CA 94111 (415) 398-7990

Copy Editors: Beverly Cronin, Chief; Faith Hanson, Warren Williamson, Hilary Selby Polk, Elizabeth Kepner, Nancy Hayes, Joan Vigneau Roy; Margaret Cook, Junior Copy Editor

Assistants: Faith Kluntz, Beverly Jackson, Lisa Jo Steiner, Jeanann Waters

Production: David R. Anderson, Assoc. Director; Jan Muller, Virginia Reardon, Michael J. Lonsky; Sherry McCarthy, Chief Typographer; Debi Fredericks, Donna Sweeney, Valerie Horn

Advertising: Deborah Porter, Supervisor; Marion Carlson, Rob Hannings, Cathy A. R. Drew, Lisa Wozmak, Jeanne Cilley, Jeanna Reenstierna; Patricia Akerly, Reader Service Coordinator; Wai Chiu Li, Advertising/Production Coordinator; Linda J. Sweeney

Advertising Sales: J. Peter Huestis, Sales Manager; Sandra Foster, Administrative Assistant

Circulation: Gregory Spitzfaden, Manager; Andrew Jackson, Asst. Manager; Agnes E. Perry, Barbara Varnum, Louise Menegus, Jennifer Price, Mary Emerson; James Bingham, Dealer Sales; Deborah J. Cadwell, Asst.; Carol Aho, Linda Turner

Marketing Communications: Horace T. Howland, Director; Vicki Reynolds, Coordinator; Timothy W. Taussig, Graphics Arts Manager; Michele P. Verville, Research Manager

Business Manager: Daniel Rodrigues

Controller's Office: Kenneth A. King, Asst. Controller, Mary E. Fluhr, Acct. & DIP Mgr.; Karen Burgess, Linda Fluhr, Vicki Bennett, Vern Rockwell, Lyda Clark, Janet Pritchard, JoAnn Walter, Julie Ferry

Traffic: N. Scott Gagnon, Manager; Brian Higgins, Cynthia Damato

Receptionist: Linda Ryan

Personnel/Office Manager: Cheryl A. Hurd

Publisher: Gene W. Simpson; John E. Hayes, Associate Publisher/Production Director; Doris R. Gamble, Publisher's Assistant

Editorial and Business Office: 70 Main Street, Peterborough, New Hampshire 03458 (603) 924-9281

Officers of McGraw-Hill Publications Company: John G. Wrede, President; Executive Vice President: Paul F. McPherson; Senior Vice President-Editorial: Ralph R. Schulz; Vice Presidents: Kemp Anderson, Business Systems Development, Shel F. Asen, Manufacturing; Harry L. Brown, Special Markets; James E. Hackett, Controller; Eric B. Herr, Planning and Development; H. John Sweger, Jr., Marketing.

Officers of the Corporation: Harold W. McGraw, Jr., Chairman; Joseph L. Dionne, President and Chief Executive Officer; Robert N. Landes, Senior Vice President and Secretary; Ralph J. Webb, Treasurer.

DEC, IBM, and Athena

Lawrence J. Curran, Editor in Chief

Forward-looking computer manufacturers are wise enough to understand that aiding education today can help computer sales tomorrow. IBM and Digital Equipment Corp. are two such companies. In an effort called Project Athena—after the Greek goddess of wisdom—DEC and IBM personal computers could become the tools of wisdom in the hands of undergraduate students at the Massachusetts Institute of Technology.

Both DEC and IBM will contribute goods and services valued at \$50 million over the five-year span of the project, which is aimed at exploring how advanced computers and computer graphics can change the ways in which college students learn. The idea is to create a "coherent" network of computers that will enable students and faculty to share resources—hardware, software and ideas—so that together they can solve problems in creative ways.

MIT officials should be applauded for using the project to seek ways to make dissimilar computers work with the same languages and operating systems. At the same time, the two companies deserve recognition for agreeing to contribute computers and talent. It's conceivable that the project will take steps toward standardizing languages and operating systems, and anything that fosters standardization in the computer business is to be encouraged.

DEC will donate more than 300 display terminals, 1600 personal computers, 63 minicomputers, and the full-time services of five employees to Project Athena. Similarly, IBM will contribute the services of five employees, 500 personal computers, 500 single-user work stations, software, maintenance, and research grants.

While DEC and IBM merit recognition for their philanthropy, the fact that today's students are tomorrow's computer buyers must have appealed to the marketing departments of both companies, which stand to reap brand-recognition and loyalty benefits from the experiment. Lest we be accused of complete cynicism, however, it should be pointed out that DEC founder and president Kenneth Olsen is an MIT alumnus who has demonstrated his company's commitment to the community. Project Athena is evidence of this, as is DEC's decision to locate a plant in Boston's heavily black Roxbury district.

DEC and IBM recognize that an investment in education is worthwhile for its own sake, and certainly won't hurt future sales. Another company with the same approach is Apple Computer Inc., which recently donated \$21 million worth of personal computers to 9250 public and private schools in California. We applaud these companies and would like to hear about others. ■

How to buy a computer by the numbers.

Introducing the Cromemco C-10 Personal Computer. Only \$1785, including software, and you get more professional features and performance for the price than with any other personal computer on the market. We've got the numbers to prove it.

The C-10 starts with a high-resolution 12" CRT that displays 25 lines with a full 80 characters on each line. Inside is a high-speed Z-80A microprocessor and 64K bytes of on-board memory. Then there's a detached, easy-to-use keyboard and a 5 1/4" disk drive with an exceptionally large 390K capacity. That's the C-10, and you won't find another ready-to-use personal computer that offers you more.

But hardware can't work alone. That's why every C-10 includes software—word processing, financial spread sheet, investment planning and BASIC. Hard-working, CP/M[®]-based software that meets your everyday needs. Software that could cost over \$1000 some-

where else. FREE with the C-10. There's really nothing else to buy.

But the C-10's numbers tell only part of the story. What they don't say is that Cromemco is already known for some of the most reliable business and scientific computers in the industry. And now for the first time, this technology is available in a personal computer.

One last number. Call **800 538-8157 x929**

for the name of your nearest Cromemco dealer, or to request literature. In California call 800 672-3470 x929. Or write Cromemco, Inc., 280 Bernardo Avenue, P.O. Box 7400, Mountain View, CA 94039. In Europe, write Cromemco A/S, Vesterbrogade 1C, 1620 Copenhagen, Denmark.

CP/M[®] is a registered trademark of Digital Research, Inc. All Cromemco products are serviced by TRW.

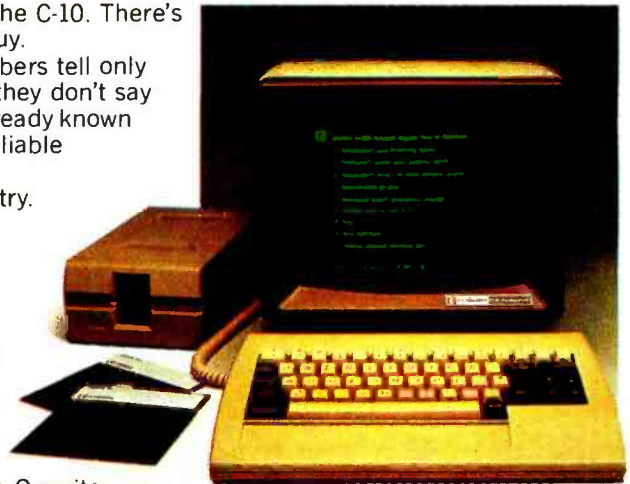

Cromemco

Tomorrow's computers today

Circle 119 on Inquiry card.

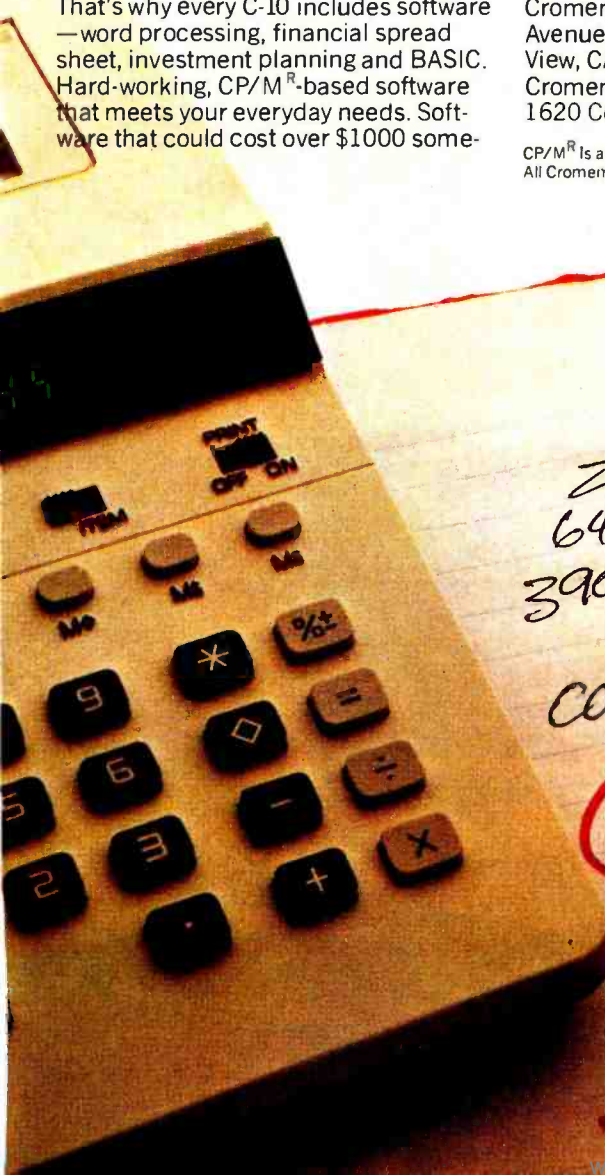

Z-80A
64K RAM
390K DISK DRIVE
12" CRT
COMPLETE SOFTWARE

\$1785

CROMEMCO

CHAMELEON BY SEEQUA... TWICE THE COMPUTER FOR \$1995 (Introductory Offer).

BOTH WORLDS OF PROCESSING

16 bit 8086 IBM compatible software runs under MS-DOS and industry standard 8 bit Z80A software runs under CP/M.

TWICE THE MEMORY

128K bytes RAM are standard, internally expandable to 256K. And dual IBM PC compatible 5 1/4" disks with 160K formatted each are included.

The following are registered trademarks:
CP/M-80 — Digital Research Inc.
MS-DOS — Microsoft
PC-DOS — IBM
Perfect Writer — Perfect Software
Perfect Calc — Perfect Software
MBasic — Microsoft

SOFTWARE INCLUDED

Your computer is delivered with SEEQUA's MS-DOS, compatible with the IBM standard 16 bit PC-DOS operating system. It includes Perfect Writer for word processing and Perfect Calc for financial analysis. And it has MBasic to let you write your own routines. Chameleon comes standard with 640 x 200 resolution black and white graphics and 320 x 200 resolution color graphics.

EXPANDABLE

Chameleon has both serial and parallel ports standard. You can add an additional serial port or the IEEE-488 port. You can even use IBM PC compatible add-on boards in our optional expansion interface package.

FITS IN YOUR ENVIRONMENT

Chameleon is at home in your office. But it's compact packaging makes it easy to carry elsewhere.

To learn more about Chameleon's power, call us at 800-638-6066. We'll put you in touch with our closest dealer.

CHAMELEON

by



**SEEQUA
COMPUTER
CORPORATION**

209 West Street
Annapolis, MD 21401
(301) 268-6650
(800) 638-6066



Staff-written highlights of late developments in the microcomputer industry.

DIGITAL RESEARCH PLANS ALTERNATIVE TO MICROSOFT HARDWARE STANDARD

The proposed MSX standard announced by Microsoft, Spectravideo, and 14 Japanese computer manufacturers won't be the only attempt to define standard hardware and software parameters in the low-cost computer market. Digital Research is also backing a proposal to unify software standards and is talking with a number of Japanese manufacturers.

To meet the MSX standard, manufacturers must use a Zilog Z80 microprocessor, a Texas Instruments TMS9918A video processor, a General Instrument AY-8910 sound processor, a Nippon Electric Co. (NEC) cassette interface chip, an Atari joystick interface, 64K bytes of RAM, and Microsoft's 32K-byte ROM-based extended BASIC. Some of the components can be purchased from other suppliers.

NEC, one of the Japanese companies that Microsoft said supported the MSX format, plans to look at any and all attempts to standardize hardware and software for low-cost game computers and plans to remain neutral until all possibilities are considered.

Both Microsoft and Spectravideo expect the standard to have the greatest impact in Japan, where the lack of a standard has held the home computer market back.

In addition to NEC, the following companies were reported by Microsoft and Spectravideo to have supported the MSX standard: Matsushita (Panasonic), Sony, Sanyo, Hitachi, Canon, Mitsubishi, Toshiba, Fujitsu, Kyocera, General, Yamaha, Pioneer, and JVC.

Specifications for the bus, I/O addresses, and game cartridge were not complete at the time of the announcement but will be included in the standard. Disk-size and operating-system specifications will not be included, but any disk system or auxiliary processors can be added onto the bus.

This fall, Spectravideo, which began shipments of its two home computers in early June, will offer a \$50 MSX adapter for its computers, one of which retails for \$300. Microsoft, Spinnaker, Sierra On-Line, and Sirius have pledged software support for the MSX standard.

COLECO'S ADAM SHAKES UP THE LOW-COST COMPUTER MARKET

Coleco's Adam has stirred up the home computer market in more ways than one. The \$600 machine was the talk of the summer Consumer Electronics Show because of its aggressively low price. Shortly afterward, however, Logical Business Machines sued Coleco and insisted that LBM owns the Adam name because it sells a much more expensive business computer called Adam. Coleco argues that it bought the trademark rights to the name from a firm that registered the name in 1976.

Coleco's Adam includes a 10-character-per-second letter-quality daisywheel printer, two Coleco Vision game controllers with numeric keypads, a ROM-based word processor, Applesoft-compatible Smart BASIC, and 80K bytes of RAM, all for less than \$600. The Adam will also be available as an expansion unit for the Coleco Vision game system for less than \$400. A "digital data pack" drive, which uses cassette-sized cartridges, is included, but Coleco would not discuss its specifications.

SOFTREND UNVEILS AURA, AN INTEGRATED SOFTWARE PACKAGE

Softrend, Wyndham, NH, announced that it will soon offer an integrated software package similar to Lotus's 1-2-3. Designed for the IBM PC and XT, Aura is built around a database manager whose various components are scheduled for release over the next few months.

Aura, the central database manager, will be released this month for \$250. In November, Aura 3, which also includes a Multiplan-like spreadsheet program and a Wang-like word processor, will be available for \$395. Aura 4, which has graphics capabilities, will also be introduced in November for \$495. Aura 5, which is scheduled for a December release, will add IBM mainframe communications and will sell for \$995. Aura will not use a mouse, but Softrend is considering voice input.

SMITH-CORONA UPDATES PRINTER, OFFERS COMPUTER-COMPATIBLE TYPEWRITER

Smith-Corona has released an updated version of its TP-1 daisywheel printer. The TP-2, a smaller and quieter printer, includes both serial and parallel ports and has DIP switches to select various print options. The TP-2 will list for \$895. The list price of the TP-1, which has been offered by some dealers for less than \$500, will drop from \$895 to \$695.

Smith-Corona also announced the Memory Correcting 3 Messenger, a computer-compatible daisywheel typewriter. It will include either a serial or parallel interface for \$599. Like the TP-1 and TP-2, the typewriter prints 12 characters per second.

IBM EMBRACES CONCURRENT CP/M-86 THROUGH DIRECT SALES

IBM's domestic sales force is now selling Digital Research's Concurrent CP/M-86 for the IBM PC and PC-XT. IBM's 9000 sales representatives will also offer Micropro's Wordstar, Ashton-Tate's dBase II, Chang Labs' Microplan financial planner, and Digital Marketing's Microlink communications program and Milestone project planner. The programs can run concurrently and can transfer data through text files. IBM's announcement, which may signal a shift in operating systems for the PC in office use, comes amid reports that IBM will emphasize direct sales of the PC at the expense of current retailers and distributors.

APPLE PRESENTS A NEW OPERATING SYSTEM FOR THE APPLE II

Apple Computer has announced ProDOS, a hierarchical, Unix-like operating system for the Apple II that is compatible with the Apple III's Sophisticated Operating System (SOS). ProDOS is now being supplied to qualified software developers and will be generally available in early 1984.

COMMODORE ANNOUNCES 70 SOFTWARE PACKAGES, INCLUDING MULTIPLAN AND MAGIC DESK

Commodore Business Machines has announced 70 new software packages for the Commodore 64, including a version of Microsoft's Multiplan spreadsheet for less than \$100. Magic Desk, an integrated software package priced under \$100, is intended to compete with Apple's Lisa and Visicorp's Visi On.

Magic Desk is actually a series of cartridges. The first, Type and File, will offer word processing and limited data management using pictures of a typewriter and file drawers and folders.

GAMELINE OFFERS ON-LINE VIDEO GAMES FOR THE ATARI VCS

Gameline, a new telecommunication system for owners of the Atari Video Computer System 2600 (VCS), is available from Control Video Corp., Vienna, VA. CVC will offer video games and information services to VCS owners who buy a Master Module cartridge, which includes an autodial modem and memory to store downloaded games or text.

Founded by William von Meister, who created The Source, Gameline will be priced at about \$1 per game, after the initial \$50 to \$60 charge for the Master Module and a one-time \$15 membership fee.

NANOBYTES

Jon Shirley, who was vice-president of computer merchandising for Tandy Corp. (Radio Shack), has left after 25 years at Tandy to become president of Microsoft Corp. . . . **Harris Semiconductor and Intel** jointly announced that both will produce a CMOS version of the Intel 8086 microprocessor and related support peripheral chips. Harris's 80C86 will be the first 16-bit CMOS microprocessor when it becomes available in the fall. Because CMOS chips require less power than regular NMOS microprocessors, the 80C86 will probably be used first in portable computers. National Semiconductor is working on a CMOS version of its 16-bit 16032 processor to be available in 1984. . . . **Microsoft** is developing Logo for Spectravideo computers. Priced at \$49.95, Microsoft Logo for Spectravideo will be available by the fourth quarter of 1983 and for the MSX standard by early 1984. No additional peripherals are needed to run Logo on the \$300 SV-318 or the SV-328. . . . **The Atari 1027**, a 20-character-per-second letter-quality printer for \$349.95, will be available this fall. Bundled with the Atari 600XL computer and the Atariwriter word processor, the printer will sell for \$599.95. . . . **Texas Instruments**, which cited the turbulent home computer market as the reason for a projected \$100-million second-quarter loss, has cancelled its plans to produce the low-cost 99/2 computer announced in January. TI said it has shipped more than one million units of its 99/4A home computer and plans to introduce the 99/8, an "advanced home computer," in the fall. . . . **Microcom**, of Norwood, MA, has announced it will license the protocol used in its hardware and software communications products. Visicorp, Apple, and GTE Telenet have agreed to support the protocol as a standard, which simplifies file transfers between microcomputers. . . . **Softyme Inc.** of San Francisco, CA, will test its Softyme Express system in an El Cerrito, CA, Computerland store. The system includes a computer with a database of available programs. When a customer decides what software package to buy, the program is transmitted to the machine and copied onto single- or double-sided disks in IBM PC-DOS 1.1 or 2.0 format. . . . In November, **Radio Shack** will release a Videotex and Office Information System based on its Model 16B multiuser system. As many as 64 terminals at a time can access up to 256 databases on the system, priced at \$12,000 and up. . . . **Digital Equipment Corp.** (DEC) announced a Winchester hard disk for its Professional Computer as well as changes to its operating system. DEC will soon begin selling its personal computers through its Business Centers.

ONE



FOR ALL

IE • IBM-PC • APPLE II • TRS-80 • R

Percom Data Corporation has one hard disk drive system for just about ALL personal computers . . . including of course . . . IBM®-PC, APPLE® II, and TRS-80®. Percom Data's innovations with 5¼" Winchester technology mean that for most personal computers . . . having a reliable hard disk system is as easy as hooking up a cable.

A Percom Data PHD™ will interface with your present system . . . and your future system . . . so if you do change computers, you can still keep your most important investment . . . your Percom Data Hard Disk Drive.

Because Percom Data helped create the industry standards of today . . . new designs in software and hardware will make your selection of a Percom Data Hard Disk Drive pay off tomorrow through system compatibility.

A Percom Data PHD works to capacity because we take the time to correctly develop interface software to your computer which leaves no performance holes for you to fall into. Percom Data knows software functionality is the key to hardware performance.

Today, Percom Data PHD supports a variety of software to match your computer:

IBM®-PC, PC DOS™ 1.1 OR 1.0

CP/M-86™, CONCURRENT CP/M-86™

APPLE®, DOS 3.3, CPM™

TRS-80® MODELS III & I, DOPLUS, LDOS

IMAGINE . . . Percom Data Winchester 5¼" technology . . . for today's computers . . . and tomorrow's.

To receive an informational booklet describing Percom Hard Disk Systems, or to determine if we have a system for your computer call our **Hard-Line Hot-Line at 1-800-527-1222.**

We will also give you the name of a nearby authorized Percom Data Dealer. Dealer inquiries are welcome.

PERCOM DATA
CORPORATION

Expanding Your Peripheral Vision

DRIVES • NETWORKS • SOFTWARE

(214) 340-7081 • 1-800-527-1222 • TELEX: 73-0401 (PERCOM)

IBM is a registered trademark of International Business Machines. APPLE is a registered trademark of Apple Computer, Inc. TRS-80 is a registered trademark of Tandy Radio Shack Corp. PHD is a registered trademark of Percom Data Corporation. COPYRIGHT 1983 PERCOM DATA CORPORATION

MILESTONE® WHEN TIME IS MONEY



As a project manager, you know the value of meticulous planning. Oversights and miscalculations can cost you crucial time and money.

Milestone is a project management and time scheduling program. It is a powerful "critical path" program for planning and analyzing virtually any project, from a cost estimate for a construction project to a schedule for installing a computer system. The applications are unlimited.

Milestone uses PERT, Performance Evaluation and Review Technique, and CPM, Critical Path Method, to plan a project, yet Milestone is one of the easiest software packages to use.

The Milestone user can change a variable and instantly Milestone will display the effect on the entire project. For instance, the estimated completion date of a particular time-crucial task may be changed. All scheduling, manpower costs and associated reports will be re-tabulated.

TIME IS MONEY. SAVE BOTH WITH MILESTONE.

The price is \$295. CP/M® and CP/M-86™ versions require 64K and 128K RAM respectively. Manual alone is \$30.

For more information see your local computer dealer or contact Digital Marketing directly.

DIGITAL MARKETING
DIGITAL MARKETING™



DIGITAL MARKETING CORPORATION

(800) 826-2222

2363 BOULEVARD CIRCLE • WALNUT CREEK • CA 94595
(415) 947-1000 • TELEX 17-1852 (DIGMKTG WNCK)

Milestone is a registered trademark of Organic Software.
CP/M is a registered trademark of Digital Research, Inc.
CP/M-86 is a trademark of Digital Research, Inc.

Letters

Is Radiation Harmful?

Edward M. Gogol's letter (April, p. 14) presented some excellent thoughts about radiation. But I have one correction. He states, "Radiation levels decrease as the square of the distance from the screen." This is true for a point source of radiation. It is not true for a 12-inch screen.

To illustrate, consider a video screen the size of a movie theater screen. A person standing one foot from the screen then moving to a distance of two feet would receive almost identical radiation, not one-quarter the radiation, as the formula for point sources would indicate.

The radiation, I believe, would be proportional to the angular area subtended by the screen at one distance compared with the angular area of the second distance. This presumes equal radiation from all areas of the screen. As you can see, it starts to become complex.

Obe O. Doan
14710 Parthenia St.
Panorama City, CA 91402

Edward Gogol's letter does not belong in a magazine of BYTE's caliber.

1. Contrary to his claims, no variety of radiation can be eliminated completely.
2. A properly designed video display does not emit significant X-radiation when operated within its design limits.
3. The claim that "with radiation, there is no threshold" is a statement that nobody can make with certainty. There is evidence pointing in all directions, including evidence that more radiation extends life (Pearson and Shaw, *Life Extension*. Warner Books, 1982, p. 516).
4. The implication that microwave exposure below a level that causes significant heating in the body is harmful is a lie that would be funny if so many people did not believe it. Fear of microwaves is a much greater health hazard than microwaves.
5. On most terminals, turning down the brightness does not reduce the electron beam acceleration voltage but increases the voltage by a small amount due to the finite resistance of the high-voltage supply and the decrease of beam current. (Total high-energy radiation is likely to decrease, as Gogol claims.)

6. The claim that a light-emitting diode display emits no radiation is stupid. It radiates waste heat, it radiates very small amounts of "nuclear" radiation from impurities in the package, and it radiates light.

7. Gogol's references are highly suspicious. The Sierra Club is a well-known Luddite organization, and Gofman's public stance suggests that he is interested in advancing his prejudices rather than finding the truth. An earlier Gofman book was described by Peter Beckman as "grotesquely biased." *The Zapping of America* is a sensationalistic book of no more scientific merit than *The Chariots of the Gods*.

Christopher M. Maple
Chief Engineer
Ingrid's Computers
8377 Capistrano Ave.
Canoga Park, CA 91304

I read with interest the letter by Edward M. Gogol critical of Dr. John Villforth of the U.S. Bureau of Radiological Health on his assurances of the near-zero present risk from ionizing radiation from video displays. The irony of this attack is amazing: in the more than 10 years that I have known Villforth, he has conducted a one-man crusade against the hazards of dental x-ray machines in particular. In this he is supported by the National Health Physics Society, which consists of 5500 people nationwide engaged in protecting mankind from the effects of ionizing radiation.

The average natural radiation background in the United States is about 100 mR per year with a large deviation from the mean, which I will discuss later. However, the average black-and-white (includes single colors like green) display tubes, including TV tubes, have an accelerating potential of 12 to 16 kilovolts (kV). The 16-kV maximum x-rays produced by this type of tube are virtually unmeasurable at the faceplate because of its thickness of $\frac{3}{8}$ to $\frac{1}{2}$ inches of glass, which is necessary to protect the near-flat surface from the crushing pressure of the air outside. The full-color display, like its TV counterpart, requires an accelerating potential of about 25 kV and is capable of producing 25-kV maximum x-rays. Because the glass faceplate is of similar thickness to that of the single-color tube, there is a greater risk for the escape of x-rays. Very sensitive devices are required

THE NEW AMPLOT-II IS ALL BUSINESS.

PLOTTER APPLICATIONS

Analytical data display • Mathematical functions • Geometric patterns • System/component characteristic display • Statistical charts • Workflow diagrams • Performance graphs • Organization charts • Creative graphics • Personal achievement charts • Instructional/reference diagrams.

The new AMPLOT-II, on computer command, can automatically produce hard-copy, 6-color business or engineering graphics in minutes. Designed for the end-user and OEM applications, its high pen speed, automatic pen retrieval and high resolution assure fast, accurate 10" x 14" plots. Compatible with most personal computers, the AMPLOT-II is economically priced at only \$1299.00 retail. Just circle the reader service number for complete engineering details.

2201 Lively Blvd. • Elk Grove Village, IL 60007

(312) 364-1180 TLX: 25-4786

REGIONAL OFFICES: Calif. (714) 662-3949 • Texas (817) 498-2334

AMDEK

Amdetek . . . your guide to innovative computing!

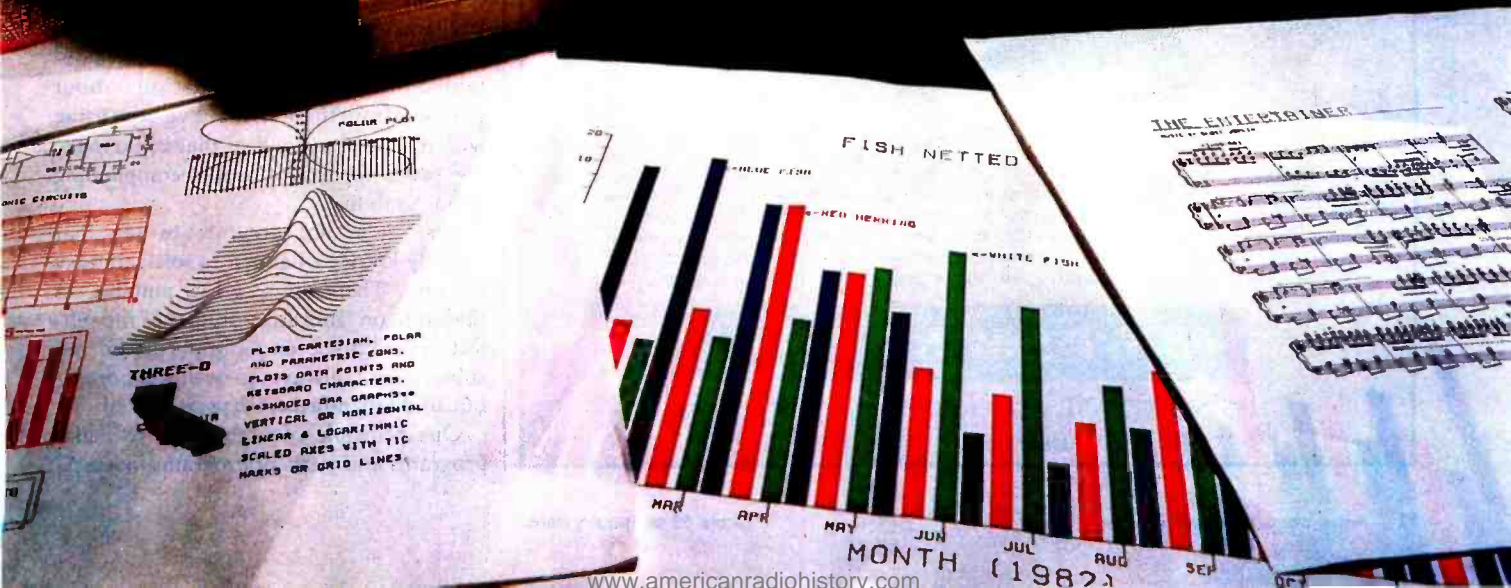

Letters.

to measure these low-energy x-rays for the equivalent of 10 to 12 hours of use per day for a full year, at levels a small fraction of the 100 mR average annual dose. It is the function of the Bureau of Radiological Health to make such measurements and issue warnings if the background level is increased.

Surprisingly, the ionizing radiation potential of the video display and its counterpart, the TV screen, is not from its x-ray potential but from its efficiency as an electrostatic precipitator. In the air of all buildings there is a radioactive noble gas called radon. When radon decays, the radioactive daughters formed are positively charged and are attracted to the glass surfaces of the display tube, adhering to the glass until the daughter's decay. We have used this phenomenon for some years to estimate the amount of radon in homes. When the TV set is turned off and an alpha counter is applied to the screen, a rapid count indicates the need for especially careful radon daughter measurements. This buildup of radiation on the viewing screen may disturb Gogol, but I for one would rather have these radon daughters on the screen than in my lungs.

While the national average background

is about 100 mR/year, there are wide variations. The area south of Chicago has water wells and radium-bearing soil that can increase this average by as much as 10 times. Similarly, the New England states have areas of granite rock in the ground that can increase the natural background 10 to 50 times. However, epidemiological studies indicate these states to be as healthy as any in the U.S. When actual measurements are substituted for assumptions, no correlation between radiation and health can be shown (Beck and Krey in *Science*, April 1983, pp. 18-24).

Gogol has quoted Dr. John Gofman's book *Radiation and Human Health* as the authority on ionizing radiation. Gofman and about 10 others have taken the position that the radiation dose below 10 mR/year is more harmful than the linear model will predict. However, most authorities have agreed that health effects cannot be scientifically verified below 10 mR/year. The linear model was chosen by the NCRP and the BEIR committees not because it could be scientifically verified but because the levels produced were considered safe and allowed dose calculations to be made relatively easier. This model extrapolates radiation effects from the 10

mR area to 0, where no radiation effects are assumed to be produced. In this no-man's-land below 10 mR, Dr. L. D. Luckey has also written a book called *Hormesis with Ionizing Radiation*, published by Chemical Rubber Press (the book costs \$60, so it might be advisable to check it out of a library). Hormesis is a neologism that, loosely translated from the Greek, means "beneficial effects." Dr. Luckey has listed more than a thousand experiments with plants and animals that exhibit beneficial effects in the 10 to 50 mR/year region. He would be the first to point out that there is still no absolute proof. However, the total biological evidence is not helping the case of increased health effects/mR in the region below 10 mR/year, the position taken by Dr. Gofman and several others.

The second authority Gogol quotes is Paul Brodeur's *The Zapping of America*. The only review I have seen of this book is a short one in the *Health Physics Newsletter* warning that the book is long on claims and short on proof. Because the subject is radio frequency and microwaves, most readers of BYTE have enough background to deal with it.

This nation has enough troubles with the economy and displaced or discarded energy without taking sides in a scientific debate about whether or not harm exists. The readers of BYTE will agree with me when I say it pays to believe almost nothing that you hear and to be very critical of what you see.

P.T. Perdue
103 Oak Lane
Oak Ridge, TN 37830

Enhancing Usability

I am writing in response to Gregg Williams' editorial (April, p. 6). Recently I purchased a microcomputer and have obtained first-hand information about usability from the software I've been using with it. I have some ideas that could make life easier for many people complaining about usability.

First, it is not accurate to say that nobody knows what makes software easy to use. There is a great amount of literature on laboratory studies of the subject. There are even more papers on the subject—not always so well supported, but by human-factors experts.

One principle of usability is to make programs and parts of programs indepen-

BYTEWRITER®

DAISY WHEEL PRINTER

- Full Olivetti typewriter warranty
- U.L. Listed



\$695
plus shipping

FEATURES

- Typewriter operation with nothing to disconnect • 10, 12 or 15 characters per inch switch selectable • Portable with carrying case • Entire interface mounted internally in the Olivetti Praxis 30 typewriter • Underlining • Cables available for most computers • Service from Olivetti dealers • Centronics compatible parallel input • Built in self test • Cartridge ribbon • 2nd keyboard switch selectable.

BYTEWRITER

125 NORTHVIEW RD., ITHACA, N.Y. 14850
(607) 272-1132

EE/EPROM PROGRAMMERS & UV ERASERS

INTRODUCING OUR NEW GANGPRO-8 & PROMPRO-8



GANGPRO-8™ MULTIPROGRAMMER\$1295.00

GANGPRO-8™ allows user to program up to 8 EE/EPROMS simultaneously using the latest state of the art programming algorithms. It can test and duplicate a wide variety of devices from 16K to 256K. There are no personality modules to buy, 8 digit alphanumeric display prompts user with messages. This unit is extremely easy to operate and is ideally suited for a production environment.

QUV-T8™ series UV EPROM ERASERS

QUV-T8/2T (\$97.50) is an industrial quality eraser, designed in a steel enclosure with a 5" wide tray, UV indicator lens, antistatic pad, 60 minute rugged timer and safety interlock switch are standard. Capacity is 24 EPROMS, 15-20 minutes erase time for 15 EPROMS.

QUV-T8/Z (\$124.95) Similar to QUV-T8/2T (with 40% faster Erase Time).

QUV-T8/2N (\$68.95) Same as the QUV-T8/2T version without the timer and safety interlock switch.

QUV-T8/1 (\$49.95) Economy model in a molded two part plastic case. Erases 15 EPROMS in 20 minutes.

PROMPRO-7™ SERIAL RS-232 STAND-ALONE \$489.00

MCS-48* FAMILY PROGRAMMING WITH PROMPRO-7

PROMPRO-7™ is an intelligent self-contained unit ideally suited for engineering development, field service, or production. It can program and verify a wide variety of 8K to 128K EPROMS. This unit has a 32K (4K BYTES), internal RAM Buffer that could be accessed by the user through a computer or terminal. This unit can also program the micro chips such as the 8478, 8749, 8751, 8741, 8742, 8755. The price includes all modules up to 32K EPROMS & The 8748 & 8749H Micros. Upload/download is done by either Motorola or Intel Hex format.

PROMPRO-8™ SERIAL RS-232 STAND-ALONE \$689.00

This extremely versatile programmer has as much as 128K (16K x 8) of internal RAM dedicated to the EE/EPROMS. This RAM buffer can be accessed either through a computer terminal, or by user target system (EPROM emulation). PROMPRO-8 8 digit alphanumeric display prompts user with the system messages. A keypad option is available for standalone editing. An impressive range of devices are programmed (as standard feature).

*MCS-48 is a registered trademark of Intel Co.

AVAILABLE SOFTWARE DRIVERS

- | | |
|-------------|--------------------|
| 1. IBM PC | 5. TEKTRONICS 8002 |
| 2. APPLE II | 6. ATARI |
| 3. MDS-ISIS | 7. TRS-80 COLOR |
| 4. CPM | 8. FLEX |

LOGICAL

*The Right Equipment for Your
Eproms at the Right Price!*

LOGICAL DEVICES, INC.

1321-E N.W. 65th PLACE · FT. LAUDERDALE, FL 33309
(305) 974-0967

DISTRIBUTORS WELCOME FOR QUALIFICATION

Circle 239 on inquiry card.

Intertec Offers The Warranty Your First Computer Should've Offered.

One-Year Factory Warranty.



The rationale behind the conventional 90-day warranty is that anything likely to go wrong will go wrong in the first 3 months.

But it can take 3 months just to get comfortable with a new system. That's the honeymoon-period, when you treat your equipment with the delicacy of a safecracker.



CompuStar can network up to 255 intelligent terminals and give each of them access to common or restricted databases.

Ah, but now it's 5 months down the road, the honeymoon is over, your equipment has finally begun to justify its cost, and that's the afternoon your processor's fan succumbs to fatigue.

Or maybe the malfunction is more gradual, like a disk-head drifting increasingly out of alignment.

Or more elusive, like an intermittent failure due to borderline components.

When You Build Them Stronger, You Can Back Them Longer.

And that's why all Intertec terminals, computer networks and disk storage systems come with a full year of coverage. Not because you'll need it, but to assure you that you won't.

See—unlike other makers, we know what we're standing behind.

We don't slap Intertec nameplates on other people's parts. We build virtually all our equipment ourselves.

And we assemble it ourselves. And we test and re-test it ourselves.

More Bytes For Your Buck.

That's also why we can offer you flatly superior dollar-values.

In single-user desk tops, for example, our SuperBrain offers twin Z80s, standard;

64 kbytes of dynamic ram, standard; up to 1.5 mbytes of disk storage, standard; CP/M 2.2* and MBasic† standard.

And compared to conventional multi-user systems, our CompuStar systems can give you many more hours of productive labor every day—because, instead of depending on a central processor for data manipulation, each workstation in a CompuStar network has its own processor and its own 64 kbytes of ram.

As a result, you can have anywhere from 2 to 255 workstations working simultaneously without suffering noticeable declines in execution-time.

Why Just Expand When You Can Up-Grade?

In fact, if you assess your expansion alternatives in terms of relative payback potential,

you're very likely to find that up-grading with Intertec equipment from scratch would be more cost-effective than burdening your existing installation with add-on's.

Dollar for dollar, the Intertec system is apt to be not only faster, more powerful and more versatile, but more reliable and better supported.

Service On Site? Within 4 Hours?

In addition to our one-year warranty, and the carry-in service provided by authorized Intertec dealers, we also have 600 factory-trained technicians to provide service on-site in 120 U.S. cities, often within 4 hours.

To arrange for that service

Since we build our equipment from scratch, we can afford to do it right and still hold down our prices.



just call our Customer Services Department at 803/798-9100. At the same time we'll be happy to give you the name of your nearest Intertec dealer.

Or write on your letterhead to Intertec Data Systems Corporation, 2300 Broad River Road, Columbia, SC 29210.

intertec

*CP/M is a registered trademark of Digital Research.
†Microsoft Basic is a registered trademark of Microsoft Corporation.



"Why on Earth would you want any other compiler?"

C86 - For Professional Programmers

Complete C Tight Code No Royalties Library Source

- **C - The Language for Professional Programmers:** C combines full control of the machine with the best productivity features. C is used by:
IBM Bell VisiCorp Digital Research MicroPro Wang Microsoft
- **A Complete Implementation -** C86 includes all of the features described by Kernigan and Ritchie. C86 delivers portability, consistency, FULL C.
- **Extensions** include long identifiers and additional data types.
- **Tight code is produced** by C86. Only needed code is linked from the library. The January 1983 Byte benchmark shows C86 as the fastest.
- **No Royalties** are payable to us on C programs you sell.
- **Library Source** provided includes UNIX I/O support, interface with and control of the Operating System and of hardware, all functions described in K & R, a Mathematics Library, and a Trigonometry Library.
- **Overlay Support** allows development of large programs.
- **Assembler** may be used to write a function. **Macro support** can increase productivity. Programs are **ROMable**.
- **Our Update Policy** helps you to keep the **Best Personal Computer C Compiler** for the 8086 as the technology improves.

See your Dealer for:

- Free Information: "C86 Product Description"..... NC
- "The C Programming Language" by K & R\$ 25.00
- "The C86 User Manual"..... 35.00
- C86 Compiler Diskette and Manual 395.00

We support **all common formats** under PC-DOS, CPM-86, MSDOS and MPM-86.

VISA and Master Card accepted. They Say It All... We Do It ALL



Computer Innovations
10 Mechanic Street
Suite J-104
Redbank, NJ 07701
201-530-0995



C86 is a trademark of Computer Innovations, Inc. CPM-86 and MPM-86 are trademarks of Digital Research. MSDOS is a trademark of Microsoft. PCDOS is a trademark of International Business Machines.

Prices subject to change without notice.

Letters

dent. In other words, an editor edits; a word-processing program processes a file to produce text output. The future does not lie along the path of integrating these two functions, as with 1-2-3 or MBA, but in separating the functions.

For example, in my editor, when I want to end a line, I should be able to press Enter. There should be no implication to a coupled word processor that Enter signifies the end of a paragraph. If I want to signal the end of a paragraph, I'll signal that in the file I'm editing, using a word-processor command, as a separate step.

There is no magic in being able to include spreadsheet output into a memo or book chapter. I should be able to copy it into the file I'm creating with my editor, or to point to it, in the file, by means of some imbedded command.

The structure of the editor output, the word-processor input, and the spreadsheet output should not imply among them any native relationships or coupling. I use such uncoupled software in my job; there is no reason that it cannot be developed for microcomputers.

In this light, the new advances may signal greater sophistication but not necessarily greater ease of use. A desktop manager is only a sophisticated analog for being able to copy one file into another.

Robert C. Maegerlein
218 Watchung Ave.
Upper Montclair, NJ 07043

On Structured Programming

As a professional programmer and a structured-programming maven as well as the owner of an S-100, 8-inch CP/M personal computer, I have watched the language diatribes fly back and forth with great interest. Although I realize my status as a high priest will leave my opinions open to suspicion, I wish to make a few points about programming and languages in general.

Despite anything else that may have been uttered in haste about structured programming, the primary lessons of a structured approach are to figure out what you want your program to do, what type and form of data it is intended to input and output, and how your program will interact with its user, *before* you write a single line of code.

The software designer usually uses some kind or combination of hierarchical tree chart, Verner-Orr diagram, and/or

Before you buy a printer look at the fine print.

There's a big difference in printers, and the proof is right before your eyes.

This is an actual printout from Digital's Letterprinter 100. As you can see, it's good enough to send out to customers.

But that's not all the Letterprinter 100 can do. Suppose, for instance, you're in a hurry.

JUST PUSH A BUTTON AND YOU CAN PRINT OUT A WHOLE PAGE OF DRAFT COPY IN LESS THAN TEN SECONDS.

There are other fine points. You can see how the Letterprinter 100 can print multiple typefaces. It can also print in **BOLD**, **double-width** and condensed. And do all these styles automatically, without stopping. And with its wide range of graphics capabilities, you can even draw your own conclusions.

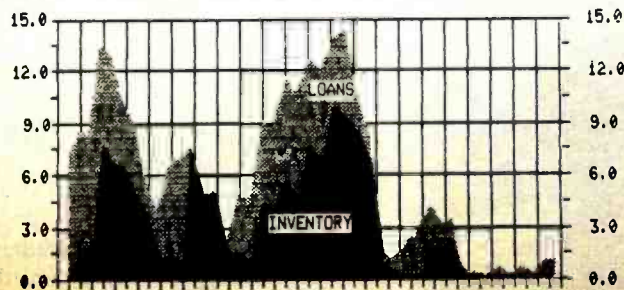

You simply can't find a more versatile printer than the Letterprinter 100. And it's just one of a family of printers we offer for Digital's personal computers and video terminals. Including a daisy-wheel printer, the LQP02, and a low-cost Personal Printer, the LA50, that still make you look good on paper.

So now that you've read the fine print, see our fine printers. Call 1-800-DIGITAL, extension 700, for the distributor near you. Or write Digital Equipment Corporation, Terminals Product Group, 2 Mt. Royal Avenue, UP01-5, Marlboro, Ma. 01752.

digital

flow chart to develop program function, and these very high-level, abstract designs are then translated to pseudocode that describes in detail the operation of the program in English, Latin, an arbitrary mixture of C and Pascal, or however you desire. This includes logic, mathematics, and I/O in any form. These steps are iterative—that is, the high-level designs are modified according to the needs discovered by the pseudocode, and the pseudocode is redefined by new, more elegant approaches that become obvious

from the tree/flow charts. So the pseudocode starts as a simplistic statement of functions that quickly evolves into a detailed list that will greatly resemble a usable computer language.

From this point, it is easy to translate the pseudocode to any computer language that is appropriate to the functions to be performed, the speed/memory requirements of the target computer, and the fluency of the programmer. This approach even allows for structured BASIC.

Is this a lot of work? Yes, but it is plac-

ing the burden at the front, so much less time is necessary to test and debug the final result. The structured approach also allows for another benefit rarely considered by hackers or even by a lot of my fellow high priests: documentation.

A program for strictly in-house use will be difficult to use after the coding is no longer fresh in your mind, and even more difficult to modify. With structured programming, when you fix your program, you can be aware of all the ramifications.

As for languages, my preference is for any language that allows me to maintain my logic structure easily within the code, a natural for all the ALGOL descendants (PL/I, Pascal, C, Ada, etc.). However, due to my work, I find myself quite often running afoul of these strongly typed languages and have to resort to good old FORTRAN. At least it runs fast, is good at math, and has mixed-record I/O. FORTRAN 77 allows something of both worlds, although it doesn't have data structures.

BASIC also has its place. Although not prone to informational error messages, BASIC is easy for a beginner to learn and get instant gratification from. With the advent of compilers, BASIC can also generate code that executes at a reasonable speed, although I need separately compiled subroutines.

Compilers that examine all of your code let you see all of your programming errors at once, an enormous advantage when dealing with related variables and functions that may have been confused somewhere along the way (built-in cross-references are a great help, too).

Curtis W. Rendon
Syntax Constructs Inc.
14522 Hiram Clarke
Houston, TX 77045

Editor's Note: For further discussion of languages, see Jerry Pournelle's article, "The Debate Goes On," on page 312.



The Data Defenders.

Once you've stored important information on full size or mini-diskettes, the trick is to keep it there the way you stored it.

That calls for a rugged first line of defense against dirt and grit, sharp objects, bending or pressure and all the other enemies of magnetic media.

And your best defense is Ring King. You get full protection for every disk, easy retrieval, ready label reference for fast searches, and maximum storage in minimum space.

For the full story on all the Ring King Data Defenders, see your Ring King Dealer or write for our Magnetic Media Filing Systems Catalog, showing our full line of storage and retrieval systems. Ring King Visibles, Inc., 215 W. Second St., Muscatine, IA 52761. (319) 263-8144.

Diskette filing systems by



Mouse: Not So Mighty

In response to Gregg Williams' editorial ("The New Generation of Human-Engineered Software," April, p. 6), the mouse of Lisa, Visi On, and their predecessor, the Xerox Star, is a truly fascinating hardware device, and on those few occasions that I have seen these devices in use, I have been impressed. But the mouse is not revolutionary, and, as its

OPEN YOUR APPLE TO A WORLD OF COMMUNICATION

Videx' new PSIO Dual Function Interface Card gives you a whole new world of communication... with a whole new ease of operation.

The PSIO allows you to use a printer (parallel output) and a modem (serial I/O port) simultaneously, through use of just one card! But best of all, the PSIO makes communicating through either method worlds easier than it's ever been before.

The PSIO lets you choose from among an unmatched range of software-selectable options, including variable baud rate selection, form width, form length, auto linefeed, linefeed mask, Xon/Xoff protocol, lowercase masking, shift wire mod support, duplex mode, parity, data format, video echo mode and a slot echo mode.

PSIO can also open up new worlds for graphics, since it can reproduce your picture on any graphics printer. Rotate your picture, enlarge it, change it as you wish.

Once you've chosen your options, the PSIO's highly sophisticated NOVRAM (non-volatile RAM) will remember and permanently save them. That means you won't have to give the same configurations over and over again... your PSIO will do it for you. And if you want to *change* those configurations, you can do it through software instead of through the confusing array of switches that other cards use.

The PSIO will work with any printer/modem you now happen to own... and it will work with any printer/modem you happen to purchase in the future. Adaptable? Definitely!

The PSIO is completely compatible with BASIC, Pascal and CP/M® systems.

The PSIO from Videx... how in the world can you do without it?!



Letters

name suggests, it is really nothing more than a rodent. Its functional predecessor was the light pen. Some years ago, light pens were fashionable devices for selecting a particular function, and they are still in use. But displays attaching light pens had to have an appropriate phosphor, and they were not as easy to program as function keys. About the same time, touch-sensitive screens were introduced, and they are still used in applications such as online catalogs in libraries; here, too, however, programming appears to be the chief stumbling block.

If the name of the game is "ease of use," the industry would be far wiser to develop touch-sensitive displays than mice. Because a display has no moving parts, it is likely to prove more durable than a mouse. And a finger placed on a display screen does not require additional desk space, as a mouse does. If an executive were having an office conference, don't you think he might rather touch his screen a couple of times than roll a mouse around his desk pressing buttons on it?

There are, obviously, many considerations at work in the development of new products. My bet, simply stated, is that the mouse is not a viable product. At best, it will limp along like bubble memory.

John P. Rash
President
Acorn Data Ltd.
611 W. 111th St., Box 57
New York, NY 10025

The High Cost of Software

I certainly don't pretend to be in favor of the theft of software, but I believe that software piracy is being fought with the wrong weapons. Perhaps software vendors need to reevaluate their marketing strategies. Simply keeping the price high because the market appears willing to support it is both a greedy and naive approach.

Vendors are not solely to blame for high prices. I believe that the average consumer pays the exorbitant prices demanded because he simply does not know the worth of a piece of software. If someone tried to sell that same person a textbook for, say, \$300, he would laugh. Yet the textbook may easily represent more hours of labor and may require more years of experience on the subject area to write. In addition, the book may not en-

joy as large a market as a good piece of software does.

I don't begrudge companies a fair profit, but I do object to exploitation. I think that if anybody is being "ripped off" in this industry it is we the consumers, not the software companies. Perhaps they are the pirates.

P. J. Lenk
2505 David Ave.
Pacific Grove, CA 93950

New, Improved Compiler

Jay Freeman's letter (April, p. 20) in regard to Intel's FORTRAN-86 version 1.0 points up some known difficulties with that past version of our compiler. The release of the FORTRAN-86 Compiler, version 2.1, that is currently being shipped to customers corrects bugs found in the previous version as well as provides new features.

Kenneth A. Pomper
Development Systems Operation
Intel Corporation
3065 Bowers Ave.
Santa Clara, CA 95051

Algorithm Amended

I recently read Timothy G. Corrigan's "Add Dimensions to Your BASIC" (March, p. 307). The idea of indexing multidimensioned arrays with a single dimension index is sound and useful. However, the algorithm introduced is in error. For instance, for a two-dimensional array with a dimension X having a maximum index of XM, and Y having a maximum of YM, the formula given for the index is

$$I = X \times YM + Y$$

Considering X to be the row dimension and Y to be the column dimension, you can see that this formula produces indices I from 0 to YM associated with the first row (X = 0) of the matrix, as it should. However, the next element I that is produced (for the second row, first column, such that X = 1, and Y = 0) is also YM. In every case, the formula repeats the last index I for the last row element for the element that is first in the next row. Ob-

Now Attractive Industrial Quality Mainframes Enclosures as low as \$200

Dual LED Display
Shock Mounted 6 Slot
Motherboard/Card Cage
PS-101 Power Supply
Power & Reset Switches, A/C Filter,
Fan, Etc.



SDS-S100-SL
8" Floppy Drive Enclosure/System
Special Lift Out Drive Rack
Fits all Regular and Slim-Line 8" Drives
Also Will Support 5-1/4" Hard Disk



SDS-S100-MFL
5-1/4" Floppy and/or Hard Drive
Enclosure/System



SDS-MF2 SDS-MIC
12 Slot S100 Computer Chassis or
8" Hard Disk Cabinet



PS-101 Power Supply
This solid supply gives you the capability of running any variety of 8" floppy or 5-1/4" floppy or hard disk drive as well as provides power for a full S100-Buss Motherboard.

Regulated:	Unregulated:
8V @ 8 amp	+16V @ 1 amp
+5V @ 5 amp	-16V @ 1 amp
+12V @ 5 amp	
+24V @ 5 amp	
-5 or -12V @ 1 amp	

SIERRA DATA SCIENCES
Fresno, California/
Product Support Division
25700 First Street, Westlake, Ohio 44145
(216) 892-1800 TELEX 980131 WDMR

Circle 355 on Inquiry card.



On the Threshold of 8-Bit Hyperspeed

At 8MHz, Sierra Data Sciences' new Z80 single-board computers are the first—and the fastest—microcomputers in their class.

Under CP/M™ they perform like single user minis. Teamed with networking TurboDOS™ their 16-bit-buss-transfers amaze the demanding 16-bit multiuser world. And at Sierra Data's production-oriented price, they bring an ever-expanding universe of CP/M compatible software into a whole new realm of price/performance reality.

Solve your need for speed. Only a reliable manufacturer with Sierra Data's undisputed technical lead and established reputation for support can deliver these features—all on board our new slave/satellite single-board computers.

HARDWARE
SOFTWARE



SIERRA DATA SCIENCES

Fresno, California/
Product Support Division
25700 First St., Westlake, Ohio 44145
(216) 892-1800 TELEX: 980131 WDMR



- Meets IEEE 696/S-100 Standards • Z80H (8MHz) Z80B (6MHz), or Z80A (4MHz), • 64K/128K*/256K*/512K* bank-selectable RAM in 4K incre-

- ments • High speed integer or Floating-point math chip* • 2 Serial ports • 2 Parallel ports • 4 Counter timers • 4K CMOS cache buffer, buss addressable in 16-bit or 8-bit increments • 4K/8K/16K EPROM • Operates under Sierra Data supported CP/M 2.2**, CP/M 3.0** and TurboDOS 1.2**

Make Sierra Data the heart of your advanced system or discover one of Sierra Data's cost-effective, turnkey systems. Sierra Data's single or multiuser 20M byte hard disk system with 8 inch slimline floppy-disk backup is shown above. Other popular configurations are shown on the previous page. Ask for Sierra Data's product catalog today.

*Optional

**TurboDOS is a Registered Trademark of Software 2000 Inc.

**CPM is a Registered Trademark of Digital Research

GUESS W MICRO

If you guessed that a Practical Peripherals Microbuffer™ printer buffer saves time, you're right. For the way it works, this inexpensive product is the most practical addition to your microcomputer system ever.

With Microbuffer, you don't have to wait for your printer to finish before you resume using your computer.

Data is received and stored at fast speeds, then released from Microbuffer's memory to your printer.

This is called buffering. The more you print, the more productive it makes your workflow.

Depending on the version of Microbuffer, these buffering capacities range from a useful 8K of random access memory — big enough for 8,000 characters of storage — up to a very large 256K — enough for 256,000 characters of storage.

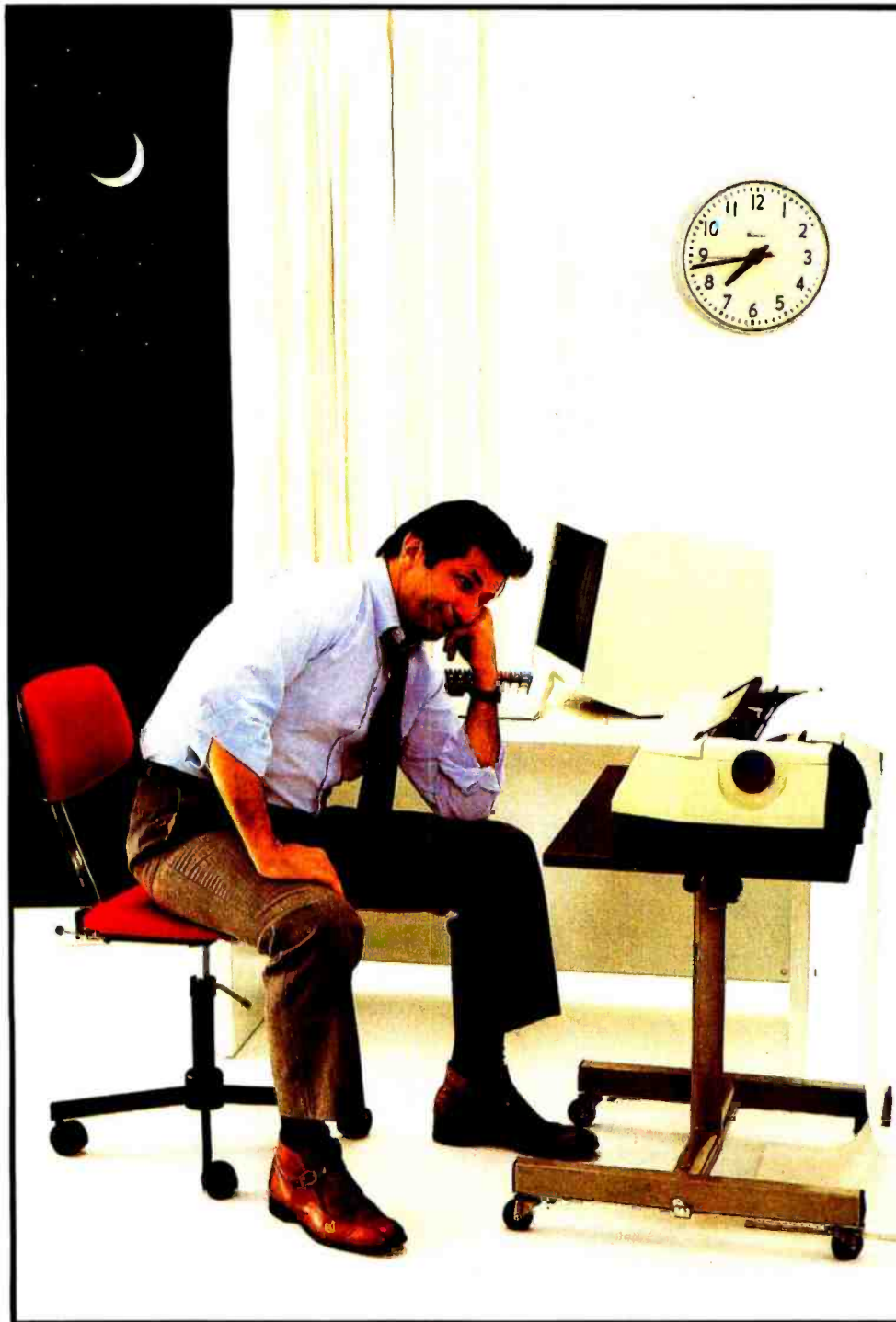

WHO HAS BUFFER.™



Practical Peripherals makes stand-alone Microbuffers for any computer and printer combination, including add-on units especially for Apple II computer and/or Epson printers.

Each has different features like graphics dumps and text formatting besides its buffering capabilities. You can choose one that's just right for your system.

Best of all, they're built to last and work exactly like they're supposed to.

If you're still guessing whether you can afford to have one, talk with any computer dealer. That's the best way to find out how practical a Practical Peripherals Microbuffer is.

**PRACTICAL
PERIPHERALS**

Practical Peripherals, Inc.
31245 La Baya Drive, Westlake Village,
California 91362. (213) 991-8200

Circle 319 on inquiry card.

viously the index I must refer to a unique array element to be of use. Perhaps an even simpler way to show that the formula is in error is to consider the two-dimensional problem of a $10(X = 0 \text{ to } 9)$ by $5(Y = 0 \text{ to } 4)$ array, for which Corrigan provided a BASIC program. You can immediately see that the maximum I obtainable from the prescribed formula occurs when X and Y are maximum and is 40, yet there are 50 elements in the array. The corresponding correct formula for the two-dimensional case is

$$I = X \times (YM + 1) + Y$$

The algorithm can be extended to a third dimension, Z , by modifying the procedure described by Corrigan. You must enclose the two-dimensional expression for I in parentheses and multiply by 1 plus the maximum value of Z , ZM , and add Z as

$$I = (X \times (YM + 1) + Y) \times (ZM + 1) + Z$$

This same algorithm can be used for any number of array dimensions just by re-

peating the process.

In addition, it might be mentioned that in many applications, especially in statistics, many square two-dimensional matrices that are encountered are symmetric, that is, the same elements are contained above and below the diagonal. An example is an intercorrelation matrix, which expresses the degrees of relationship between all possible pairs of variables. Traditional statistical software for mainframes has ignored this fact and stored the whole redundant array in memory; there was plenty of memory to spare. With matrices of even modest size, this is undesirable with the limited RAM available to most microcomputers. An index similar to that introduced above can be created to index only the nonredundant information in such a matrix. Again, assuming X as the row dimension and Y as the column dimension, the appropriate two-dimensional formula is

$$I = (X \times (X + 1)) / 2 + Y$$

Using this formula, the appropriate indices will be created for all the elements of the "bottom" nonredundant portion of

such a square symmetric matrix.

John D. Morris, Associate Professor
 Box 8143
 Educational Leadership & Research
 Georgia Southern College
 Statesboro, GA 30458

"A More Powerful Pencil"

In his letter on "the myth of computer literacy" (March, p. 16), Dr. E. J. Neiburger hit the nail right on the head. One of the nails, that is. There are several more nails to be hit before we hammer down the lid on this argument.

In one basic sense Dr. Neiburger is totally right. If you want to use a computer for certain strictly defined, limited applications, you need know nothing more than how to turn it on, load the programs, and follow the prompts on the screen. If all you ever intend to use a computer for is these predefined applications, then there is no such thing as computer literacy. To fill out a form you need to know how to read and write but not how

**AZTEC C — 'C' PROGRAM DEVELOPMENT SYSTEM
 PORTABLE SOFTWARE APPLE CP/M IBM**

WHY PROFESSIONALS CHOOSE AZTEC C

SOFTWARE SYSTEMS

- AZTEC C is the most complete implementation of UNIX V7 'C' available for microcomputers.
- AZTEC C is portable. 'C' code can be freely moved between UNIX V7 and microcomputer systems. AZTEC C is available for PC DOS (MSDOS), CP/M 86 (MP/M 86), CP/M 80 (MP/M 80), APPLE DOS, MODEL III (IV), COMMODORE 64, and ATARI. All versions of AZTEC C are source compatible.
- AZTEC C is a complete development system that includes relocating assembler, linkage editor, library utility, debugging aids, overlay support, interfaces to Microsoft and Digital Research development software, and run time routines for I/O, utility, and scientific functions. Source for all library routines is provided.
- AZTEC C generates fast native code for the 6502, 8080, Z80, 8088, and 8086.
- Cross compilers are available from PDP-11, 8086, 8080, and 6502 processors.
- Since its release in 1981, AZTEC C has been acquired by several thousand users. Commercial applications include a wide variety of business, scientific, word processing, database, entertainment and financial applications.

PRICE LIST

AZTEC C86	PC DOS (MSDOS)	\$249
AZTEC C83	CP/M 86 (MP/M 86)	249
AZTEC C80	CP/M 80 (MP/M 80)	199
AZTEC C65	APPLE DOS	199
AZTEC C65	COM 64 OR ATARI	199
AZTEC Cross Compilers	PDP-11	2,000
AZTEC Cross Compilers	Other	500

MANNA SOFTWARE SYSTEMS
 Box 55, Shrewsbury, NJ 07701
 Order by phone or mail. Specify product and disk format.
 Check Money Orders, COD, VISA, MC, and purchase orders
 and acceptable NJ add.6% sales tax.

Order phone: (201) 780-4004
 Tech information: (201) 530-7997
 Tech support: (201) 530-7708

Shipping: COD, 2nd day delivery, or Canada, add \$5. Canada 2nd day or US next day delivery, add \$20. Outside North America, add \$20, and for 2nd day add \$75



ADAM B. GREEN



Taught by the nation's leading dBASE II expert, Adam B. Green, whose dBASE II User's Guide has sold over 30,000 copies.

"Green doesn't just teach dBASE syntax, he establishes the fundamental terminology and organization behind data-base management systems."

dNEWS - Ashton-Tate

Teach your computer who's BOSS!

Attend a dBase II or 1-2-3 SoftwareBanc Seminar

Here are just a few of SoftwareBanc Seminars' clients:

ABC	Digital Research	Price Waterhouse
Arthur Anderson	Dunn & Bradstreet	RCA
Boeing Aerospace	E.F. Hutton	Shell Oil
CBS	Fox & Geller	Smithsonian Institute
Chase Manhattan Bank	IBM	U.S. Air Force
Citibank	Internal Revenue Service	U.S. Navy
Computerland	Laventhol & Horwath	U.S. Postal Service
Cornell University	Merrill Lynch	Victor Business Products
Digital Equipment Corp.	Osborne Computer Corp.	Westinghouse
	Polaroid Corp.	Xerox

1983 Schedule of Classes

Anchorage August 11-12 Sheraton Anchorage	New York September 19-23 New York Hilton	Dallas November 14-18 AMFAC
Washington, D.C. August 29-September 2 Marriott Crystal Gateway	Chicago October 17-21 Hyatt Regency	San Diego December 12-16 Hyatt Islandia

4 Days of Instruction

9:00 A.M. to 5:00 P.M.
dBASE II Fundamentals
dBASE II Programming
Advanced dBASE II
Problem Solving with 1-2-3

State of the Art Presentation

- Video and sound system
- Buffet Lunch/Coffee Breaks
- Video tapes of program authors
- Portfolio of Comprehensive Seminar Notes

\$175 Per Day of Instruction
Pre-payment may be made by:
MasterCard, VISA or Check.
Call or write to register



SoftwareBanc Seminars
661 Massachusetts Avenue
Arlington, MA 02174
(800) 451-2502
(617) 641-1241 in MA

to think. Using a computer only for pre-defined applications is similar to filling out forms.

I think that using a microcomputer this way misses the whole point of the personal computer "revolution." In considering personal computers, I prefer the analogy of pencil literacy to telephone literacy. Intrinsically the pencil is one of the simplest of human artifacts, and yet it takes great skill and creativity to realize the full potential of a pencil as a personal tool. With a pencil I can write, draw, calculate, communicate, and remember. The things I can do with a pencil are limited to what I can imagine and the skill I have in carrying through my imaginings. A personal computer for me is a more powerful pencil.

My point is that there is such a thing as computer literacy. I don't propose that to be computer literate all of us need to become programmers. I do believe that we need to learn to understand the scope of the tool we are dealing with and how to use it creatively, not by rote. And to "use" means just that, to invest the time and effort to learn the commands and procedures of packages such as database-management systems, spreadsheets, and word processors.

Computer literacy means learning how to use and exploit the tool that a personal computer is. If you use your pencil just to copy over the accounts, you'll be the clerk, not the boss. The same is true with a personal computer.

Douglas F. Yriart
1005 Bayview Overlook
Stafford, VA 22554

**Are Computers Like
Telephones?**

Dr. Neiburger's contention that computer literacy is overrated (Letters column, March, p. 16) is well taken and almost convincing. Those of us who work with microcomputers and spend a lot of time thinking about them do seem to be caught up in an imbroglia of expensive gadgetry and words that have capital letters stuck oddly in their middles. Like any new toy, personal computers have been subject to an intense media hype that tends to throw the whole issue out of perspective.

But computers aren't like telephones at all, and to reduce operating a computer to merely turning it on and following the in-

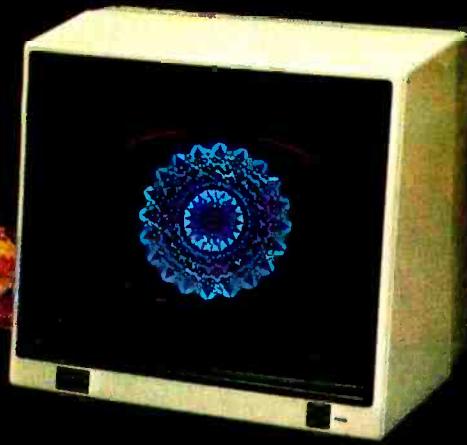

Sakata COLOR MONITORS
... we promise performance

NOW you can obtain the finest quality line of CRT DISPLAY MONITORS at prices far below competition, (if there is any) BUT, with unsurpassed quality found in more expensive CRT MONITORS. Illustrated 13" COLOR Model SC-300 is super high resolution—RGB video input—with every quality feature you'd expect and demand; compatible with IBM, APPLE, ATARI 800, NEC and other fine personal, popular computers. The modern design will sell itself on sight and the splendid performance will meet your most discriminating requirements.

Also available: Model SG-1000 . . . 12" monochrome, high resolution CRT MONITOR. Model SC-100 . . . 13" composite COLOR CRT MONITOR. Model SC-200 . . . 13" RGB high resolution COLOR CRT MONITOR.

SAKATA CRT MONITORS are available wherever personal computers are sold . . . Or, write for technical, illustrated literature and prices.

SAKATA U.S.A. CORPORATION
651 Bonnie Lane
Elk Grove Village, IL 60007
(312) 593-3211/800-323-6647 (outside Illinois)



"SAKATA . . . serving industry
worldwide . . . since 1896"

SAKATA SC-300
COMPATIBILITY CHART

COMPUTER	SC-300 COLOR
APPLE II	✓
APPLE III	✓
ATARI-800	
COMMODORE-64	
IBM-PC	✓
NEC-PC	✓
OSBORNE	
TI-99	
VIC-20	

NOTE: ON CERTAIN COMPUTERS ADAPTER CABLE REQUIRED.



THE PRICE OF **FAST** WAS JUST SHATTERED!

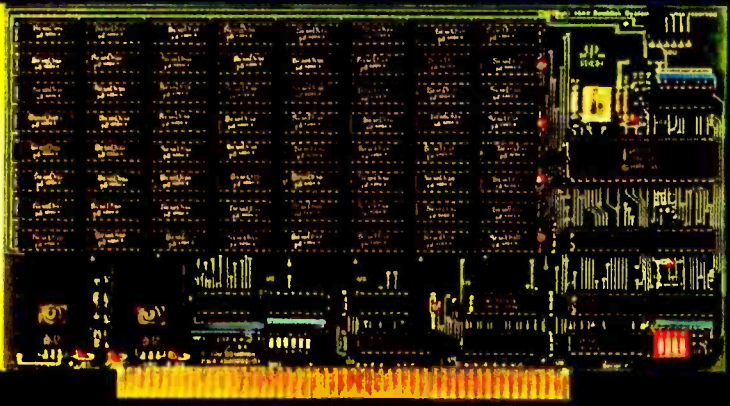
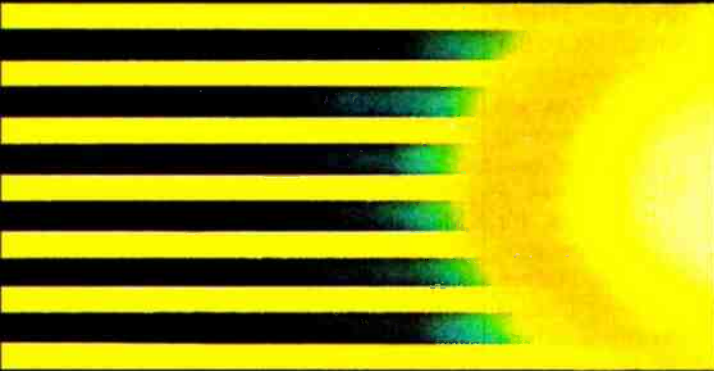

256Kbyte SemiDisk™ **\$995**

For more than a year, we've been making the most advanced disk emulator available for microcomputers. The one that's taken the "waiting" out of computing. Now, we have some more news that'll set the world on fire: A price cut! The NEW 256Kbyte board is only \$995. And the 512Kbyte SemiDisks for the S-100 and TRS-80 Model II are \$1495. (1Mbyte unit is \$2350.) So, what are you waiting for?

The SemiDisk is the **ORIGINAL** single-board microcomputer disk emulator. It has a greater storage density than any other: 1 Mbyte per board! And we've been shipping them for over a year! We didn't do this with 'me too' engineering. Our products are true innovations, based on reliable technology and proven designs, without the need for custom components.

SemiDisk Systems, Inc.

P.O. Box GG Beaverton, OR 97075 (503) 642-3100

Call 503-646-5510 for CBBS®/NW, a SemiDisk-equipped computer bulletin board.

SemiDisk trademark of SemiDisk Systems, Inc. Copyright © 1983 SemiDisk Systems, Inc.

Floppies are ok for data transfer or long-term storage. But they fall far short as online storage. If you are using high level languages, spelling checkers, word processors, databases and other disk-intensive software, you know the price you are paying: time. Your productivity is going down the drain. The SemiDisk disk emulator will save time and increase your productivity.

Even better, Release 5.0 of the SemiDisk CP/M-80 installation software contains SemiSpool, an automatic printer buffer. No extra hardware is required; it's all in the software. Up to 8 Mbytes of buffer space! It's a better solution than a \$350 64Kbyte printer buffer that wastes space on your desk. Send documents of almost any length to the printer at a very high speed, then continue using the computer immediately. No Waiting!

SemiDisk

It's the disk the others are trying to copy.

still



NO WAITING

structions on the screen is a gross oversimplification. If this were the only trick, there would be no manufacturers' support services, no user groups, no manuals to teach us how to read our manuals. Even a novice should have some insight into the workings of the machine, and that means getting a sense of the mathematical and electrical properties involved and learning the terms that describe them. A user who seeks only to snap the disk into the drive and have his or her problems magically solved will probably never feel confident about the computer or use it creatively.

Many people view computers with skepticism and deny their usefulness—at one time or another we've all received someone else's bank statement. But when a computer is working properly it can help enormously. When it is not working properly, it is better if the person punching the keys has a vague idea of how to clean up the mess.

Terry Nasta
Senior Editor
Computing Physician
515 Madison Ave.
New York, NY 10022

E. J. Neiberger replies:

Mr. Nasta's comments on my letter are well taken. It is true that many computer systems and software are not as easy to operate as a telephone, but that is due to poor design or equipment limitations (lack of memory for help screens, etc.).

The telephone is a complicated instrument with many buttons, signal tones, and series of numbers to be dialed (try a long-distance number through MCI). But the telephone is easy to use because its use is *easy* to understand. Even 3-year-old children routinely use them. My point is that a well-designed computer and program are also easy to use. Take a templated Visicalc type of program, for example. Load your disk, turn on your computer, and fill in the requested blanks when they appear on the screen. There is no problem with this "user friendly" type of program. You need not be "computer literate" to use it. Visicalc may require knowledge of a few commands gleaned from reading a manual, but no big effort.

Conversely, many programs may require considerable effort in order to run, but this problem can usually be solved with better programming and design.

With rare exceptions, I believe that a truly good program and computer system should not require any complicated manuals or other documentation. Like the telephone, it should be designed to function well in the hands of the novice. Those firms that develop systems along this line will thrive. Those that hide their deficiencies under the buzzword "computer literacy" will fail.

Double-sided Recording with Perpendicular Media

"The Promise of Perpendicular Magnetic Recording" by Clark E. Johnson Jr. (March, p. 56) contains serious omissions and errors of fact.

Johnson did not mention the fact that "double-sided" recording is meaningless with perpendicular recording because the recording magnetic field necessarily passes *through* the medium. Of course, the increased density made possible with perpendicular recording makes double-sided recording less advantageous. Nevertheless, the disadvantages of double-sided recording are still present and may be magnified.

Most prominent of these presumed disadvantages is the fact that the read/write head, instead of being one small component, must have two parts, on opposite sides of the medium, and that these two parts must always be accurately aligned. This condition is desirable but not indispensable with double-sided longitudinal recording. Furthermore, the length of the magnetic flux lines, which must always form a closed loop, is vastly greater with perpendicular recording because the lines must pass around the edge of the medium rather than remain within the head and its supporting structure. These long flux lines require low magnetic reluctance in the access mechanism to enable the detecting circuits to pick up the changes in magnetic flux when reading and to enable the drive circuits to generate appropriate signals when writing.

Johnson also mentioned the possibility of using perpendicular recording of audio signals and the applicability of data compression to such recordings. That may be true, but his example betrays a gross unfamiliarity with musical quality. He asks, "Why record all 800,000 bits of data for a soprano who sustains the same note for an entire second?" The question is, what constitutes the "same" note? All vocalists and many instrumentalists—notably violins

GET FULL VALUE FROM YOUR VICTOR 9000™

with the UCSD p-SYSTEM™ IV.1

Get the most from your VICTOR 9000 as well as from your software development efforts. The power and portability of the UCSD p-System is available for the VICTOR 9000 from TDI.

The Standard Development System Includes:

- Full Screen Editor, Filer, Assembler and other Utilities
- The UCSD Pascal Compiler
- Native Code Generator
- Ram Disk Support Above 128K
- Turtlegraphics - full use of VICTOR screen (800 x 400)
- Complete documentation

Options:

- Fortran 77 and Basic compilers
- Hard disk support



TDI SYSTEMS, INC
620 HUNGERFORD DR.
ROCKVILLE, MD 20850
(301) 340-8700

TDI LIMITED
29 ALMA VALE RD.
BRISTOL, U.K. BS8 2HL
0272 742 796

VICTOR 9000 is a trademark of VICTOR TECHNOLOGIES, INC.
UCSD p-SYSTEM and UCSD PASCAL are trademarks of the Regents of the University of California

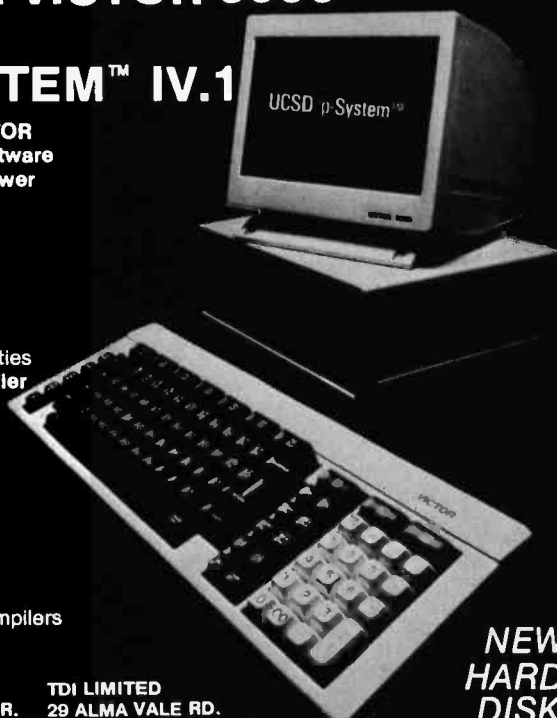

**NEW
HARD
DISK
SUPPORT**

The IMS Computer Family



All IMS systems can be configured with 8 bit or 16 bit microprocessors.

A B 5000SX/8000SX

The SX table top computer systems are the ideal choice for companies with expansion in mind. These systems are easily expandable from one to eight users, each having his own Microprocessor, 64K of memory, and local peripheral control.

- A** The 5000SX chassis has three full width 5¼ inch Floppy/Winchester slots available. Winchesters from 6.3 MByte to 19.2 MByte require one full width slot each. Floppies from 500 KBytes to 1.0 MBytes of storage require ½ slot per drive.
- B** The 8000SX chassis has two full width 8 inch Floppy/Winchester slots available with the added capacity to house a magnetic tape bulk memory subsystem. Winchesters from 6.3 to 85 MByte storage require one full width slot each and 1.6 MByte Floppies require ½ slot per drive.

C 8000S "MAXIMA"

The IMS 8000S "MAXIMA" Computer system is designed for the company where many people must have access to a large common pool of information. Basically the system configuration of the 8000S is similar to that of the SX Table Top system with the added capability to support up to 16 users each with his own Microprocessor and 64K of memory. The 8000S has five full width 8" Floppy/Winchester slots available supporting any combination of full width Winchesters and ½ width Floppies plus a magnetic tape bulk memory subsystem.

D 5000IS - "The Desktop Mainframe"

From the crystal clear monitor with a true typist keyboard to the high performance power supply—the 5000IS is the most versatile integrated system available—best of all, the 5000IS can serve as the host processor of a multi-user, multiprocessing system supporting four users.

E IMS "ULTIMA" Terminal

The "ULTIMA" CRT Terminal has a separate microprocessor for each of its major functions: Local Intelligence, Screen and Keyboard Control. It can be customized to perform functions the others don't even talk about. The contoured keyboard has a touch the best typist will really appreciate.

F Portable Cartridge Tape Back Up Unit

The IMS Stand Alone Tape Data Storage and Retrieval Subsystem may be added to any IMS system.

To compliment the best microcomputers available, IMS supplies a complete and comprehensive set of business application software.

For complete information and specifications plus the location of your nearby IMS International dealer, call or write today!
(702) 883-7611

IMS
INTERNATIONAL

2800 Lockheed Way, Carson City, Nevada 89701 • Telex 910-395-6051

and other stringed instruments—introduce tiny changes of pitch and not-so-tiny changes in volume when sustaining a note. These modulations constitute the difference between a musical note and a steam whistle. Anyone listening to a performance by a would-be musician who does not use them finds the experience rather unpleasant. A recording of a performance would necessarily include these modulations, making the compression of data considerably more complicated than Johnson implies, if not impossible.

Wallace B. Riley
309 Garces Dr.
San Francisco, CA 94132

Clark E. Johnson replies:

Contrary to the opinion Riley expressed in his letter, double-sided recording with perpendicular media is not only fairly straightforward but easy to implement in a practical configuration. We at Vertimag use a single-sided, single-pole head shim that provides the advantages of the Iwasaki single-pole, double-sided approach but mounts in a standard floppy-

disk head button configuration. The flux from the record/write thin film travels through the perpendicular storage media, through the permalloy back layer, and returns through a massive ferrite piece that connects to the shim. No alignment is required other than the normal azimuth restrictions of high-density recording.

With such a head configuration in a 96-turns-per-inch disk drive using 50 turns at a standard disk-drive speed of 300 rpm and using our own double-layer media, we have a read-back signal of approximately 1 millivolt peak-to-peak. This signal, at 30,000 bits per inch, exceeds that from particulate media at one-fifth the density.

With regard to the application of perpendicular recording technology to audio applications, I did not intend to imply the elimination of redundancy, as Riley inferred. Because perpendicular recording in its most efficient implementation uses saturation recording, one can obtain extraordinarily high signal-to-noise ratios by pulse with modulation—what is essentially a binary digital signal. The quantization of the audio signal (equivalent to

the number of bits in a conventional digital audio system) is limited only by the atomic columnar structure of the media itself. This limitation is equivalent to approximately 400,000 bits per inch.

Information Hiding

First it was hacking, then structured programming, and now information hiding. As a programmer who has outgrown the need to produce arcane works of twisted genius, I can appreciate the innovations that facilitate ease of implementation and maintenance. When I see an article like "Information Hiding: A Brief Example" (April, p. 442) I'm gratified by the thought that such techniques will free programmers to create useful, higher-quality software. While our early methodology was justified by slow processors, small memories, and inefficient mass-storage devices, the new machines' capabilities might never be realized if we were to continue so clumsily. I hope BYTE will continue to cater to the growing number of us

JUST SAY THE PASSWORD™ TO GET 1200 BAUD, PROGRAMMABLE AUTO DIAL, FOR \$449*

- 300/1200 Baud
- Auto Dial, Telpac™ software available
- Full or Half Duplex
- Audio Phone Line Monitor
- Two-Year Limited Warranty

Password™ is the new USR™ friendly modem, designed for use with any small computer on the market today. We have compressed into its miniature (shown actual size) case every operating feature for unattended high speed telecomputing. With auto dial/answer and auto mode/speed select there is little to do but turn it on. So compact it mounts on the computer with Velcro®; when you carry your computer you can pocket your Password. So brilliantly conceived it achieves all this with just 12 tiny integrated circuits (a presage of long trouble-free service). If your dealer doesn't know the Password yet, write or call for complete specifications.

**Suggested list for Password complete with power, phone, RS232 interface cables. Telpac™ software optional extra, \$79.*

Password, Telpac, USR logo and the U.S. Robotics corporate name are all trademarks of U.S. Robotics Inc.



U.S. ROBOTICS INC.™

1123 WEST WASHINGTON
CHICAGO, ILLINOIS 60607
(312) 733-0497

Circle 402 on Inquiry card.





Reach out and byte someone!

Your desk-top computer system is only a beginning — plug a low-cost UDS modem into the RS-232 port and a whole new world of communications opens up!

UDS modems add a new dimension to personal computers. For professional use, a modem permits two-way, hard-copy communication between home office and branches or among the branches themselves. Electronic mail becomes a reality. Sales, cost and inventory updates can be sent over ordinary telephone lines at economical, after-hours rates.

When you use your computer for personal applications, the modem allows you to access up-to-date market information, receive news and weather summaries, check airline schedules or even electronically scan out-of-town newspapers. Long-distance game playing and computer-age personal correspondence become instant realities.

The wide range of UDS modems includes one that fits your requirement perfectly. Top of the line is the micro-processor-based 212 A/D which communicates at 0-300 or 1200 bps, stores and automatically dials up to five 30-digit numbers and includes a complete prompting menu and full



automatic test capabilities. Yet, with all these features, it costs only \$745.

At the other extreme is the \$145 103 LP, offering simultaneous two-way communications at 0-300 bps without an AC power cord. This unit siphons operating energy directly from the telephone line!

In between is a large variety of units — many of them in the LP no-power-supply design and all fully FCC certified for direct connection to the telephone system.

Don't be a computer hermit — treat your system to a UDS modem; then you can reach out and byte someone! For details, contact your favorite computer dealer or Universal Data Systems, 5000 Bradford Drive, Huntsville, AL 35805. Telephone 205/837-8100.

 **Universal Data Systems**



MOTOROLA INC.
Information Systems Group

Circle 408 on Inquiry card.

PROCESS CONTROL

(TAURUS ONE) + (YOUR PC) = (PROCESS CONTROL SYSTEM)

Now a new micro computer based data acquisition and control front end that gives you:—

Power that's easy to use:— Plugs into any RS232C, RS422, or IEEE 488 port on your Personal Computer • Powerful Command functions that include: simple reads and writes, high speed block analog reads, pulse counting, frequency, change of state detection, direct thermocouple input, and more • Results in engineering units • Convenient screw terminal panels • Compatible isolated AC/DC 3 amp switchers and isolated input sensing •

Power that's easy to cost justify:—

A full range of input output modules provide: 12 bit analog inputs with 4 programmable ranges for inputs from $\pm 10\text{mV}$ to $\pm 10\text{V}$, digital I/O, counters, pulse output, 12 bit analog output, 4-20 MA input/output, thermocouples • Stand alone mode with direct terminal support • Remote operation • Communicates simultaneously to three computers • Internal diagnostics •

Power that's easy to expand:— Plug in expansion to 1024 points • User memory allows downline load of user written functions and programs • EPROM space for special user functions • Rack mount hardware available for all options •

TAURUS ONE®

Write or call for more information to:

 **TAURUS
COMPUTER
PRODUCTS
INC.**

IN U.S.A.

C/O I.M.S.
P.O. BOX 1663
BUFFALO, N.Y.
14203
(603) 673-6662

IN CANADA

P.O. BOX 911
STATION "U"
TORONTO, ONT.
M8Z 5P9
(613) 226-5361
TELEX: 053-3577

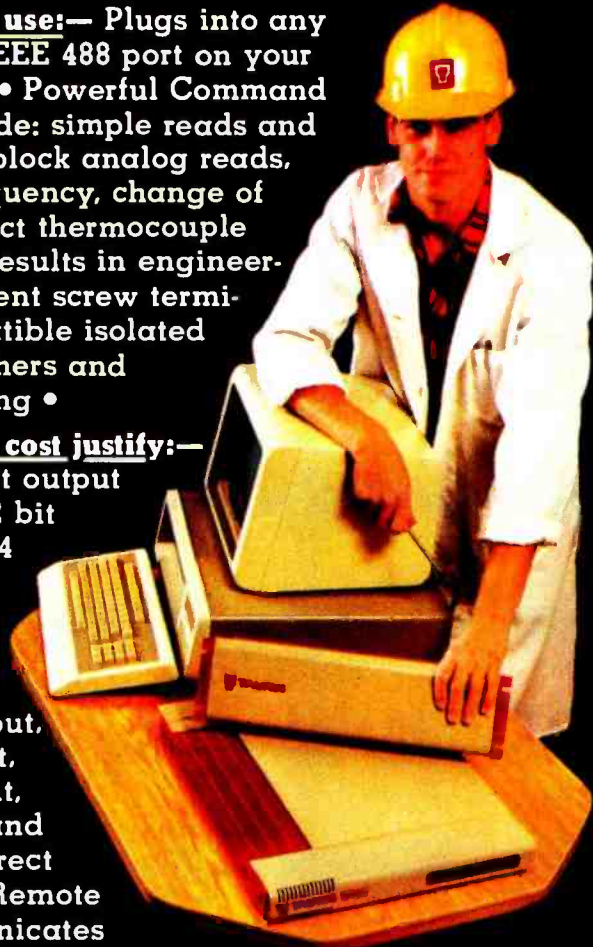

Letters

who implement the clearer design strategies.

Rudy Smith
4601 Southwest 58 Ave.
Miami, FL 33155

Mass Storage for Apple Writer

An undocumented feature in the new version of Apple Writer for the Apple IIe makes it possible to use a Corvus mass-storage device. Here are the necessary steps:

1. Place the Corvus controller card in Apple IIe slot 6.
2. Place the Disk II controller card in slot 7.
3. Turn the Apple IIe on and press the C key once while the system is booting up.
4. A prompt will appear: "ENABLE CORVUS IN SLOT 6 (Y/N) :"; press Y and RETURN.

Steps 3 and 4 are carried out each time the system is turned on. These steps allow Apple Writer IIe to work with a Corvus drive that has been formatted with DOS 3.3 volumes.

Paul Lutus, President
Walden Software Inc.
2021 Placer Rd.
Sunny Valley, OR 97497 ■

BYTE's Bits

Electronic Help-Wanted Comes to Valley

Connexions, the electronics industry's two-way, online help-wanted publication, has expanded its operations from the East Coast to California's Silicon Valley. This service lets recruiters post job openings and prescreen applicants while offering job hunters a comprehensive list of current career opportunities that they can respond to electronically with a resume and a cover letter. Further details are available from Connexions, 20863 Stevens Creek Blvd., Cupertino, CA 95014, (408) 252-7882. The East Coast headquarters for Connexions is located at 55 Wheeler St., Cambridge, MA 02138, (617) 492-1690. ■

← Circle 380 on Inquiry card.

We've got a hit on the charts.

One picture is worth a thousand words. Or numbers.

Now there's a simple way to transform pages and pages of business data into a single, dramatic format.

Introducing DR Graph™—high quality business graphics software from Digital Research™. It lets you create impressive business charts, graphs, or any combination of both—quickly and easily. You can even build graphs from electronic spreadsheets such as VisiCalc® and SuperCalc™.

See what you're creating, instantly.

Think of it as painting by numbers. Because DR Graph actually lets you create your graph step-by-step.

First, enter the data you wish illustrated. Then just choose from the menu, hit a key, and take a quick look at what you've created—instantly.

Make your axes thick, your border lines thin. Go with solid, or broken grid lines. Add color when and wherever you please for all your special reports. It's easy to experiment until the graph format is perfect. Then DR Graph can print it, plot it, or store it for future use.

You get the versatility you need.

DR Graph lets you convert business data into dozens of



Multiple graphs on a single page

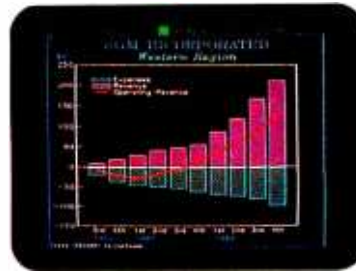

Combine bar and line graphs with a simple keystroke.



Pie charts with exploding slices add impact.

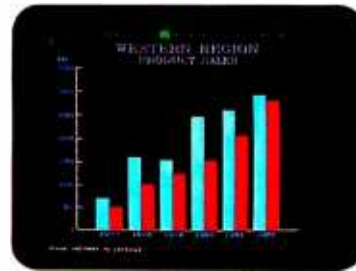

Create clustered bar graphs.

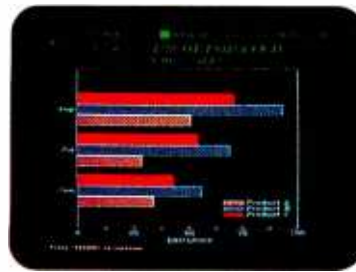

Tap a key and vertical bars turn horizontal.

personalized choices. Do you like your bars vertical or horizontal, stacked or clustered? How about adding line curves to your bar graph? Or special labels on the axis? With DR Graph, you've got it. All with the simple stroke of a key. DR Graph even displays up to four different graphs on a single page.

Mix words with your pictures.

DR Graph lets you write comments on your graphs, too. You not only control the size and color of the type, but also have four different typestyles to choose from. Write your own legends and titles. Or add additional text right onto the graph—exactly where you want it.

Plus, its 8 color and 6 pattern fills provide customized highlighting. So, your presentation graphs will be as professional as you are.

All the business graphics you'll ever need, ready to roll.

DR Graph works with today's leading microcomputers, as well as with a wide range of printers and plotters. All you need is Digital Research's GSX™ graphics enhancement for your computer's operating system. Contact your computer manufacturer, or stop by the CP/M Library™ at your computer shop for an eye-opening demonstration. Call 800-227-1617, ext. 400 (in California 800-772-3545, ext. 400) for a free, full-color brochure.



**DIGITAL
RESEARCH™**

The best of everything in business graphics.

VisiCalc is a registered trademark of VisiCorp. SuperCalc is a trademark of SORCIM Corporation.

The logo, tagline, DR Graph, GSX and CP/M Library are either trademarks or registered trademarks of Digital Research Inc. ©1983 Digital Research Inc.

QUADBOARD™

256K Memory Expansion

Expandable in 64K increments, Quadboard™ is socketed for 256K bytes of memory. Full parity and checking standard.

Qspool™

With Qspool, you can also use part of system memory as a software print buffer. Choose from 8K to 56K of memory and stop waiting for your printer.

QuadRAM Drive™

This software program lets you use part of your total system memory as multiple disk drives. Super-fast drives that let you store important information for easy access.

Chronograph

Quadboard features a real time chronograph to always keep your system's clock/calendar up-to-date. Even when your system's been off for months.

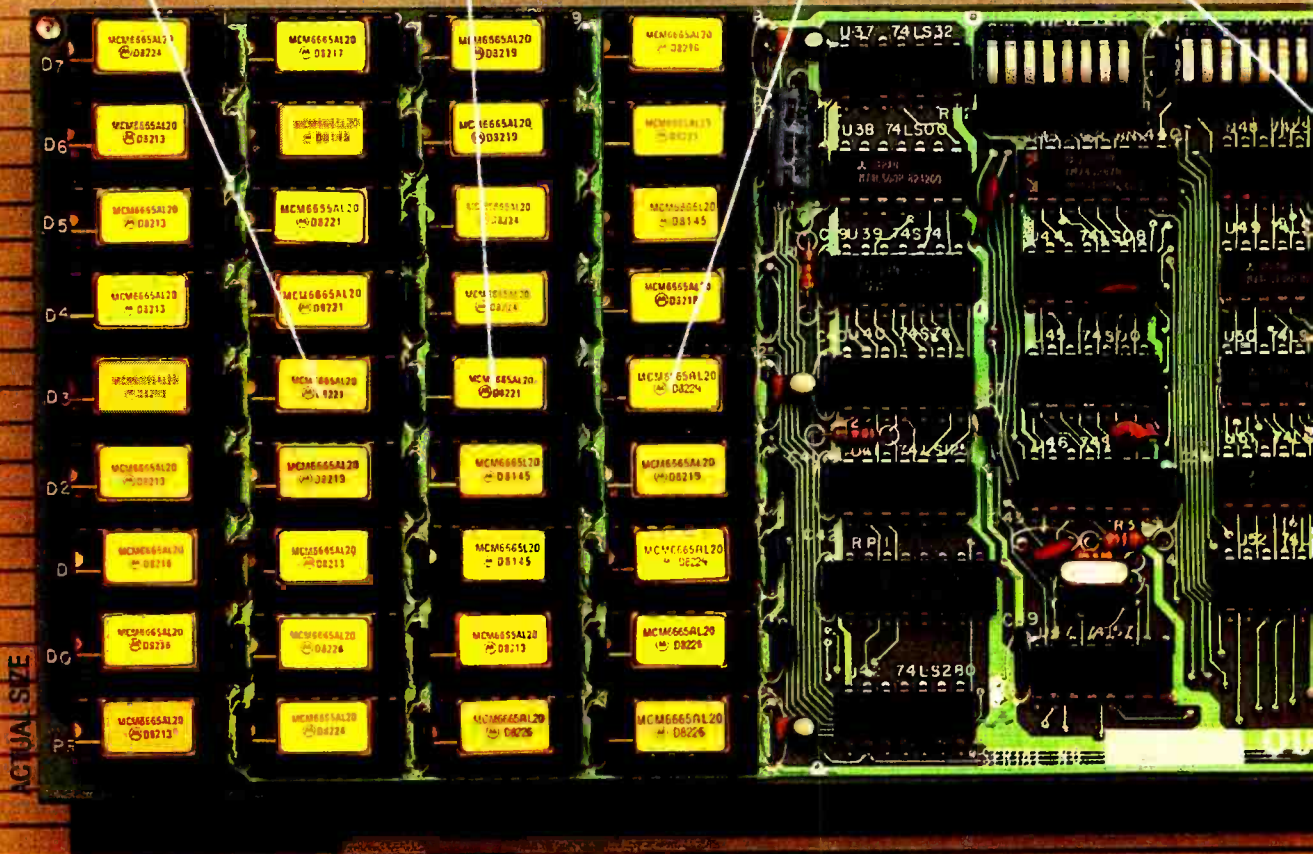

THE FIRST AND ONLY BOARD YOUR IBM PC MAY EVER NEED.

Your IBM Personal Computer is very versatile. New functions and applications are being developed for it everyday. And now with Quadram's Quadboard, you can keep your PC options open for tomorrow's technology. In the tradition of Quadram Quality, six of the most needed PC functions have been com-

bined into one package, using only one expansion slot. Your remaining IBM slots are left free for future expansion needs.

All-On-One-Board and Software, too.

Every board you may ever need for your IBM PC is in the Quadboard package. From serial port to print buffer. Plus, there's Quad-Master software, too. Included on this disk are utilities for ac-

curately setting the Quadboard's chronograph for time and date, and for performing diagnostics on all Quadboard functions. There's



BY QUADRAM™

Parallel Port

There's a parallel I/O designed to operate most printers and parallel devices.

Serial Port

Used for connecting modems, printers, and other serial devices, Quadboard's serial adapter can be configured as COM1 or COM2 and fully supports IBM PC communications software.

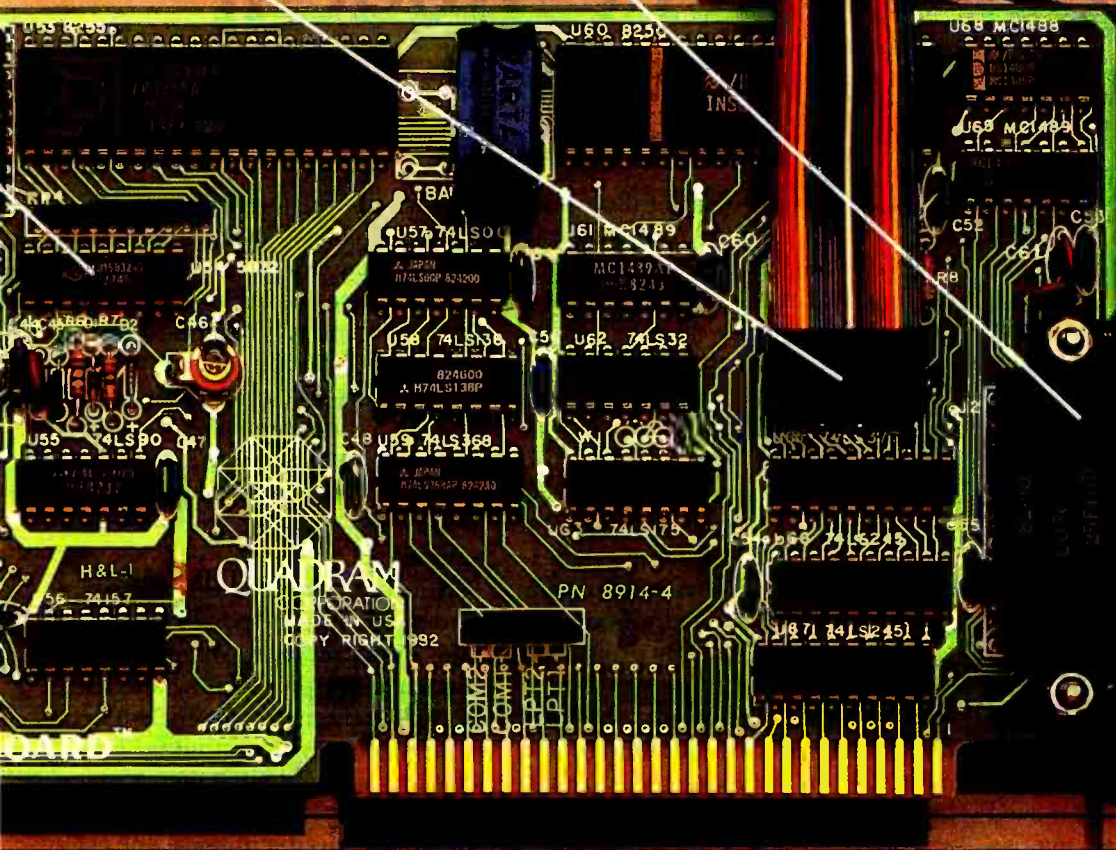

also Qswap™, the feature that lets you switch line printers one and two, back and forth, as your printing needs change.

Proven Design

Quadboard is the number one IBM PC option board on the market today. Nothing even comes close, because Quadboard is designed with performance in mind. Engineered for dependability and built with only the finest components available. Each board has been thoroughly tested and "burned-in" for years of reliable service.

INCREDIBLE PRICE, ASK YOUR DEALER.

Our full line of IBM PC accessories: Quadboard II, Quad 512+, Quadcolor, Quadchrome, Quadscreen, Quadjet, Quadmodem, Memory Board, Serial Board (Single or Dual ports), Parallel Board, Chronograph, and Microfazer.



All products are sold through local professional computer dealers. If yours does not stock Quadram, please ask him to call us at (404) 923-6666.



4355 International Blvd./Norcross, Ga. 30093
(404) 923-6666/TWX 810-766-4915 (QUADRAM NCBS)

Circle 330 on Inquiry card.

Build a Power-Line Carrier-Current Modem

Communicate using electrical power wiring

by Steve Ciarcia

"Jiggle the printer cable, Jeanette." My assistant reached through the rat's nest of wires behind the computer and grabbed the one connected to the printer. As she moved it, I identified its other end from my cramped vantage point beneath the workbench and pulled it through a slot to attach it to my latest project. I was glad that what we were doing would keep us from having to run cables around the Circuit Cellar so often.

I have long had video terminals, printers, and other data-communicating equipment located at various places in the Circuit Cellar and around the upper stories of my home (see reference 3). Eventually the pain of rerouting cables whenever I moved a peripheral device got to me, so about a year ago I designed a communication system that would save having to string new wires every time. My system revolved around a *carrier-current modem*, which operates in much the same manner as the familiar telephone modem but sends its signals over electrical power wiring instead of over a telephone line.

After I pressed the carrier-current modems into service (with a little

help), they served faithfully and I turned my attention to other projects, some of which have appeared in this column. But as of late more and more of my readers have written to me asking for help on how to send data through the AC power line. Apparently the widespread use of and media attention to the BSR X-10 Home Control System and similar products have given many people the idea of using the generally unexploited carrier-current modem for communication. Indeed, about five years ago I published a project on building a remote-control system that communicated through the AC power wiring of a building (see reference 4). It worked very much like the BSR X-10 as a carrier-current remote controller.

I hesitated to present the carrier-current modem as a Circuit Cellar project until now because I feel there is more to general-purpose carrier-current communication than meets the eye.

Simple on/off remote control is different. In most control applications, the communication is generally half-duplex or simplex; the transmission is limited to an intermittent tone or pulse burst that merely triggers a specific receiver into a binary control state. If the receiver is not activated properly by a single transmission

because of interference, it's easy to send the control burst more than once. (Many computer control systems that use the BSR X-10 receivers send the same control code 10 times to make sure it is received.) But in general-purpose serial data communication, proper reception of every bit may be necessary, and errors in reception of the data may negate the usefulness of carrier-current operation.

To successfully use a carrier-current modem and the AC power wiring for data communication, we must either tolerate a dropped bit now and then or implement an intelligent protocol of error checking, redundant transmission, and handshaking. A really dependable power-line communication system has the physical link (AC-line transmission and reception) as only one of its components.

I was going to wait until I had perfected the control and error-checking protocols for use with the carrier-current modem, but the increasing interest indicated by my mail suggested that many experimenters might benefit from building a simple carrier-current modem; at least the physical part of the connection could be set up, even if the protocols and software are not ready.

This month's project, a modem for data communication using the AC

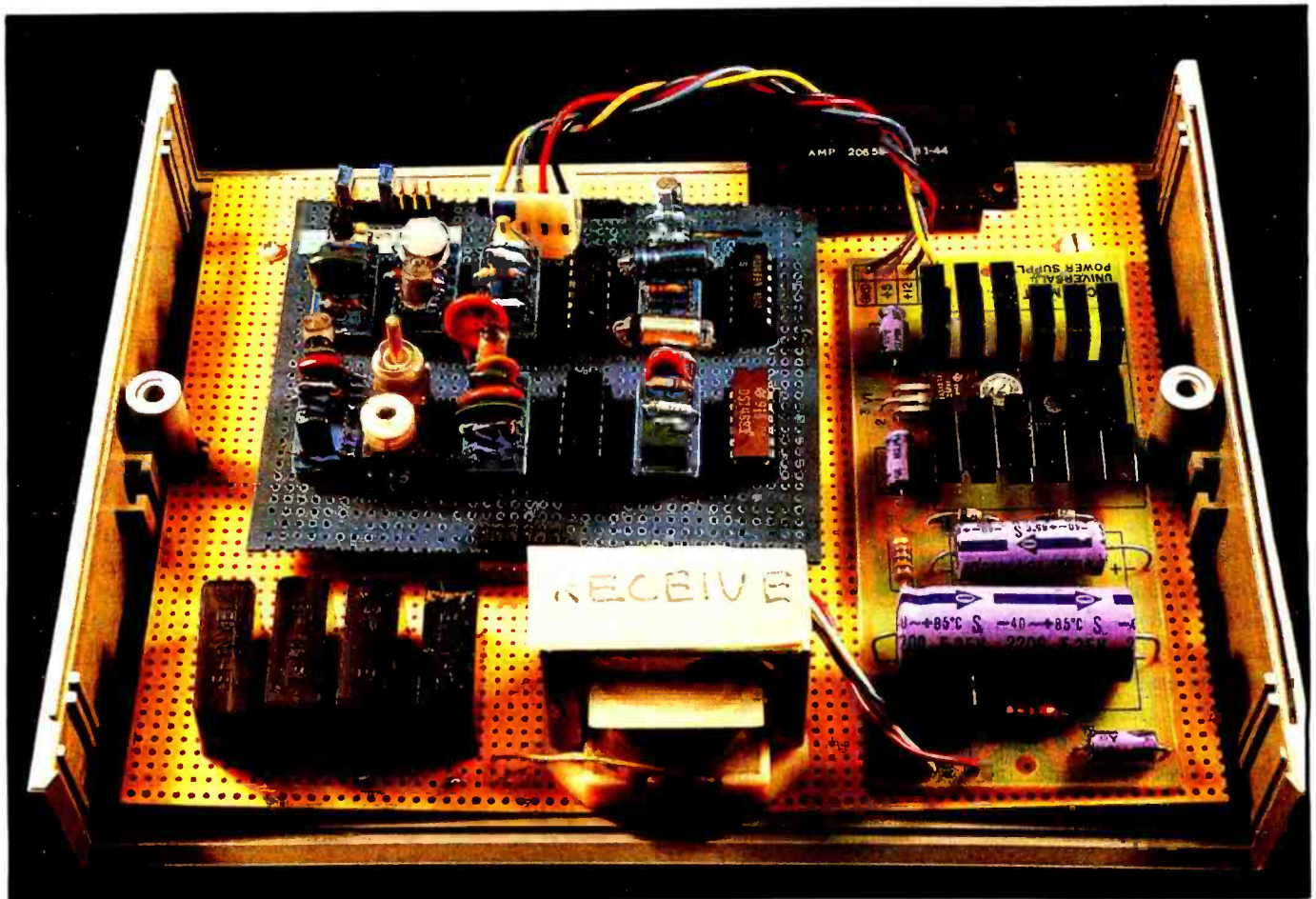

Photo 1: Prototype of the Circuit Cellar CCM-1 carrier-current modem, which transmits serial data over the AC power line at 1200 bits per second. When in originate mode, the modem transmits mark signals at 90 kHz and space signals at 95 kHz; the answer mode transmits marks at 80 kHz and spaces at 85 kHz. The receive unit, shown here, differs from the transmit unit only in the frequency-selecting passive components.

power line, is mostly an analog circuit. Successful operation of the modem, therefore, depends much more on tweaking and tuning the components than do digital computer-related projects. I am presenting this two-chip modem chiefly to discuss the principles involved, with some emphasis on selecting components for this application. Because the principles are susceptible to broad application, this knowledge should also be useful in understanding other modem designs as well.

All Modems Are Not Alike

The modem, named after a contraction of the words "modulator" and "demodulator," is a fairly common piece of computer equipment. You've probably seen modems built for sending data over telephone lines, and you may have read my March Circuit Cellar article about a low-cost

modem (see reference 2). A modem allows two pieces of digital equipment to communicate with each other over long distances without having a direct hard-wired connection between them. With a telephone modem, the telephone lines form the communication path.

Modems of the usual type translate the voltage levels of the digital input signal (usually RS-232C levels) to tones at two frequencies, one of which signifies a logic 0, the other, a logic 1. The process of shifting the frequency of the output tone as the logic levels change is called *frequency-shift keying*, and the modems are called frequency-shift keyed, or FSK, modems.

To allow communication in two directions at once (full-duplex mode), rather than in only one (half-duplex), two pairs of frequencies are used, avoiding conflict when both ends of

the connection talk at the same time. (By convention, one pair of tones is called the "originate" set, and the other is called the "answer" set. The two terms merely signify which set of frequencies each unit is using; no implication is intended regarding the content or origin of the data itself.) For compatibility, modems are built to adhere to certain standards of operation; the most common system in North America for low-speed modems was first used in the Bell System's Model 103 modem, so Bell-103-type modems abound.

Carrier-Current Systems

The AC power line is similar in some respects to the telephone line. One similarity is clear: we can send data through the power line by using an FSK modem.

Obviously, in addition to the data we want to transmit, the power lines

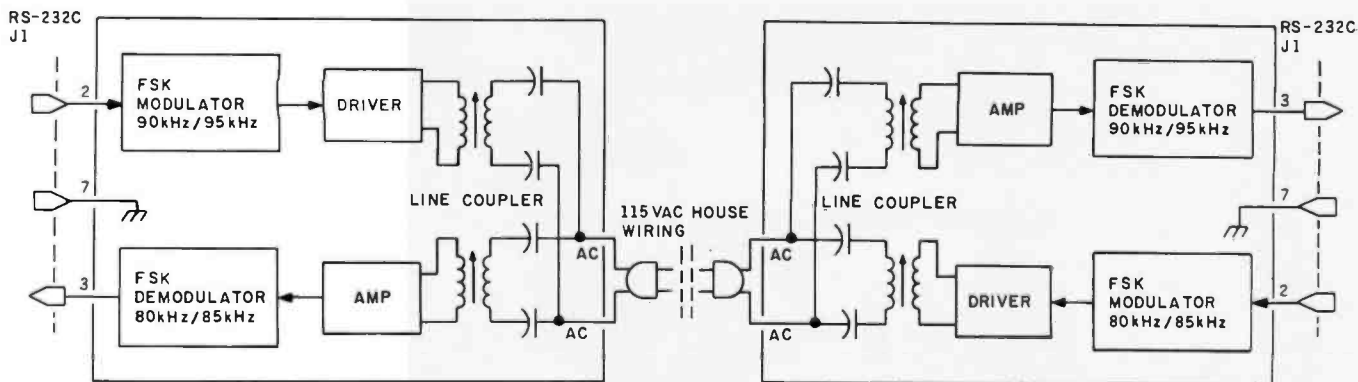

Figure 1: Block diagram of a data-communication system employing carrier-current modems. The AC power wiring of the building is used to carry the frequency-shift-keyed transmission.

must continue to carry power or we won't be able to operate the computer equipment. The carrier-current communication system superimposes a high-frequency signal on the 60-Hz power-carrying signal. On an oscilloscope, this is viewed as an additional small voltage carried on or riding atop the 115-V (volt) alternating current. At the receiving end, the modem filters out the 60-Hz signal and any other noise components on the power line, demodulating only the transmitted frequency. Unfortunately, the power line sometimes has an impedance less than 2 ohms, along with thousand-volt noise spikes that make it a hazardous environment and a less-than-optimal communication medium.

There is a price to be paid for the simplicity of this communication system. Unlike the complex digital carrier-current systems, which transmit around the zero-crossing interval of the power signal, the analog FSK carrier-current modems are more sensitive to line peculiarities and noise. However, the digital species is much more complex, and after all, my intention was to present a build-it-yourself project. Learning a little black art for the sake of simplicity can't hurt.

Carrier-Current Modem Circuit

Figure 1 is the block diagram of a carrier-current modem, which consists of three basic components: modulator/driver, amplifier/demodulator, and AC-line coupler. The simplest usable system consists of two

modems, one attached to each of two pieces of data-communicating equipment. One of the two modems is arbitrarily designated as the originating modem and the other as the answering modem. As in the case of telephone communication, two sets of FSK frequencies are defined, although the power-line modems operate at much higher frequencies than the telephone-line type. The connections from the communicating equipment to the modulator and demodulator on each modem are through an RS-232C DB-25 connector. The driver and amplifier sections are in turn connected to the AC line through the coupler, the crucial component.

In a direct-connect telephone modem, the coupler is usually a 600-ohm isolation transformer, and the characteristics of the line are well defined. But in a carrier-current modem, the coupling transformer is very often a tuned circuit selected to resonate within the passband of the FSK tones to improve the signal-to-noise ratio in this particularly noisy environment. While tuned couplers are not always used, most carrier-current driver circuits do employ them to increase the transmission range and receiver selectivity. For most experimenters, the driver and coupler are the hardest sections to construct because so much depends on selecting, balancing, and adjusting the components.

Taming the AC Line

Figure 2 shows two typical carrier-

current driver-coupler circuits. Both consist of a transformer capacitively isolated from the AC line; 0.22- μ F (microfarad) 600-V capacitors are recommended. Any 0.1-mH (millihenry) slug-tuned transformer will probably work, but I have had best success with standard low-Q (low-resonance) miniature IF (intermediate-frequency) transformers used in transistor radios. In practice, the circuit of figure 2b is less sensitive to component selection and more easily tuned.

If you have any doubts about whether a particular transformer will work, a few brute-force tests can help you tame the AC line and give you the confidence to build the rest of the modem circuit. *Just remember that working directly with the AC power line is dangerous if you aren't careful.*

Begin by building two couplers, one driver, and one receiver, using the component values and circuit layout in the schematic diagram of figure 3. (I'll get around to discussing it shortly.) Temporarily apply power to the driver section and attach it (carefully!) through its coupler to the AC line. The receiver should be powered and connected through its coupler across the AC line at some other nearby location.

Use an oscilloscope (connected to the AC line through an isolation transformer for safety) to monitor the signal present across the secondary coil of the receiver transformer (or from the collector of transistor Q2 to ground), while you inject a signal for transmission using a sine-wave func-

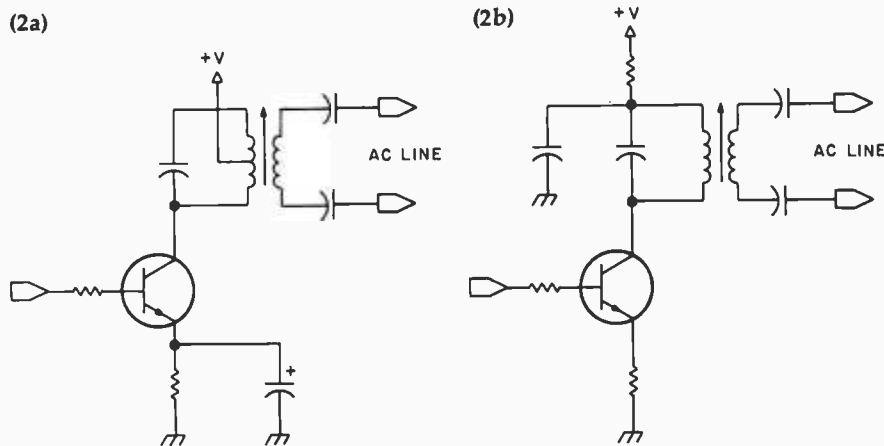

Figure 2: Two possible schemes for coupling the modulator/driver portion of the carrier-current modem to the AC line. The circuit of figure 2b is the more stable.

tion generator attached to the base of the driver transistor, Q1. Sweep the frequency between 50 kHz and 150 kHz until you detect the same frequency (at greater than 10 mV [millivolts]) at the receiver. Take care that you are receiving the fundamental frequency and not a harmonic. Don't be too surprised at the strange electrical noise you'll no doubt observe.

You can shift the detection band somewhat by adjusting the tuning slug in and out of the transformer windings or by changing the capacitor across the transformer secondary. The objective is to find the frequency band where the signal level at the receiver is highest. The band should be about 20 kHz wide; the frequency can go as high as 300 kHz (the upper frequency limit of the demodulator) if necessary.

In my case the best results were obtained between 80 kHz and 100 kHz, so I arbitrarily set two originate and answer frequency pairs within this band. One modem transmits on 90 and 95 kHz and receives on 80 and 85 kHz; conversely, the other modem transmits on 80 and 85 kHz and receives on 90 and 95 kHz. In a simple system, any originate and answer frequency pairs that work are acceptable because each frequency pair has its own tuned coupler. I recommend that the frequency separation between the mark and space tones be 5 kHz or less to facilitate easy demodulation. I only caution you not to set any frequency that is a multiple (or submultiple) of another one used in

the system.

Remember that, in an analog FSK carrier-current communication system, success largely depends on your peaking the resonance of the coils and finding the proper transmission bands. I can't provide a parts list of components values that will be guaranteed to work because the behavior of parts in the list could be other than that predicted, due to performance and tolerance variations. The most important "component" in the coupler sections is your understanding the objective and knowing how to pursue it through testing and adjustment.

Fortunately, component selection in the FSK modulator and demodulator sections is much more straightforward and follows some basic formulas defined by the frequency and application. However, because it is possible that you might choose frequency pairs different from those in my design, I'll discuss the derivation of the component values rather than just the results.

Exar XR-2206 Modulator

First, let's consider the modulator. The XR-2206 is a function-generator integrated circuit, made by Exar Integrated Systems, which can produce sine, square, and triangular output waveforms at frequencies ranging from 0.01 Hz to 1 MHz. It is ideally suited for FSK applications because it can be set for two different time bases and digitally switched between them. A functional block diagram of

the XR-2206 and typical FSK circuit is shown in figure 4.

The mark and space frequencies can be independently set by the choice of timing resistors R2 and R3 and the capacitor between pins 4 and 5. The FSK input signal is applied to pin 9. A high logic-input signal to pin 9 produces the frequency:

$$f_{high} = \frac{1}{R2 \times C}$$

and a low-level input signal produces the frequency:

$$f_{low} = \frac{1}{R3 \times C}$$

where R2 and R3 are in ohms and C is in farads.

R2 and R3 should be between 10 kilohms and 100 kilohms, and the capacitor should be polycarbonate, polystyrene, or Mylar for temperature stability. I chose to use a 0.001- μ F capacitor, which produces the following resistor values for the frequency pairs I chose:

R2: 85 kHz, 11.76 kilohms
95 kHz, 10.53 kilohms

R3: 80 kHz, 12.50 kilohms
90 kHz, 11.11 kilohms

In the case of R2 and R3, you can use the nearest 1-percent-tolerance resistor or use a potentiometer in combination with the closest 5 percent fixed value.

You must also consider the settings of resistors R1 and R5, which adjust for minimum total harmonic distortion. In our case, where a few-tenths-percent distortion is irrelevant, pins 15 and 16 may be left open and R1 can be replaced by a fixed 200-ohm resistor. With R1 installed (same effect as closing switch S1), the output at pin 2 is a sine wave with an output impedance of 600 ohms and amplitude set by R4. The remaining components serve to stabilize operation and are the same for all frequencies.

XR-2211 Demodulator

The Exar XR-2211 is a phase-locked-loop (PLL) integrated circuit especially designed for data communication

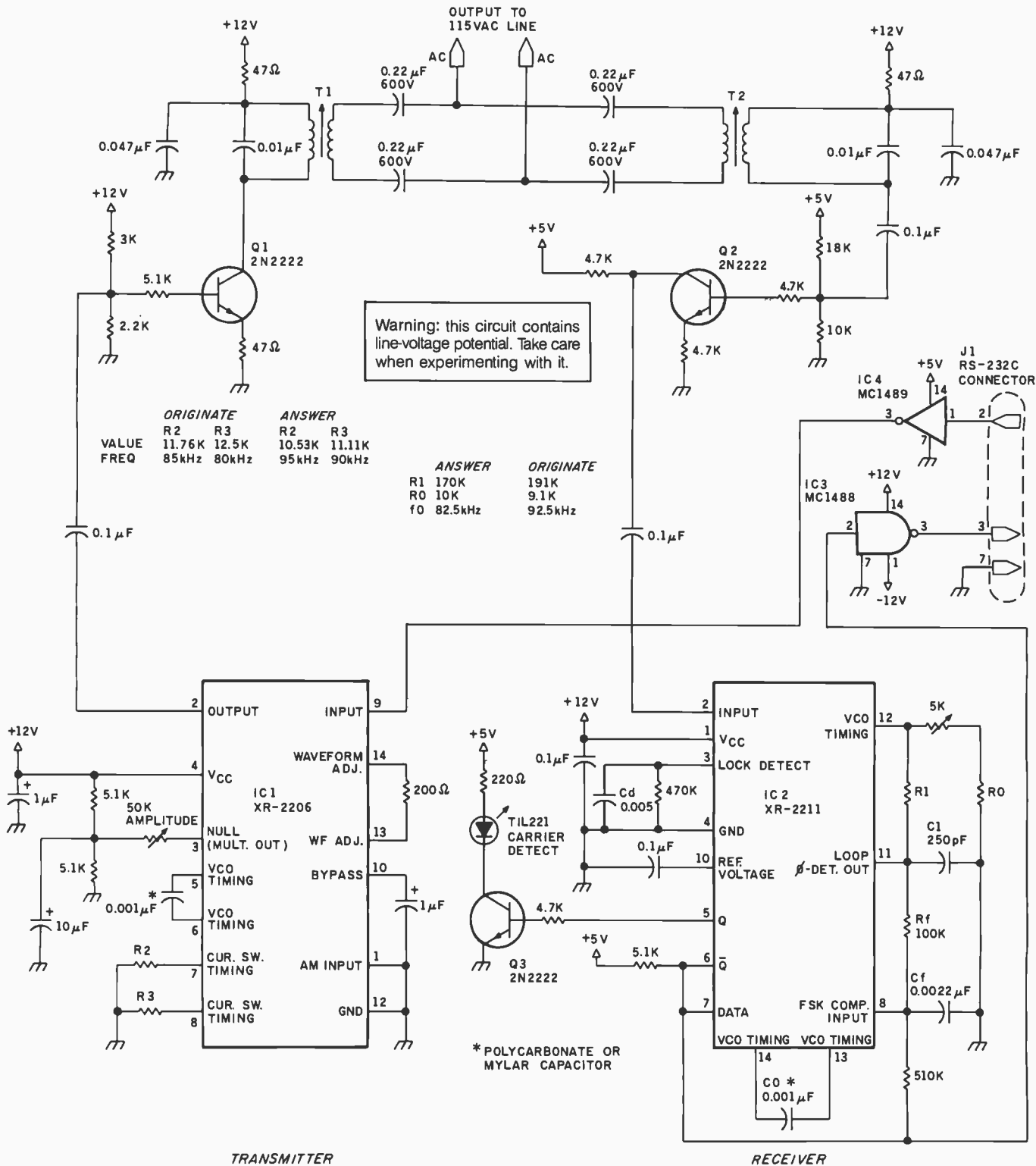

Figure 3: Schematic diagram of a complete carrier-current modem. The originate-mode modem transmits mark signals at 90 kHz and space signals at 95 kHz; the answer modem transmits marks at 80 kHz and spaces at 85 kHz. This diagram shows the circuit for one end of the link; two such units are needed in the system with the proper component values differing between them. In one unit, the wiring of pins 2 and 3 of J1 should be reversed.

and particularly suited for FSK applications. It operates over a frequency range of 0.01 Hz to 300 kHz and can accommodate analog input signals between 2 mV and 3 V. An XR-2211

functional block diagram and typical FSK demodulator circuit are shown in figure 5. Frequency-shift-keyed input signals fed into pin 2 of the XR-2211 must be capacitively coupled

through a 0.1-µF capacitor. The internal impedance is 20 kilohms, and the minimum recommended input signal is 10 mV.

The first order of business is to set

C1 sets the loop-filter time constant and damping factor. The value of R1 is determined by the mark/space frequency difference:

$$R1 = \frac{R0 \times f_0}{(f_1 - f_2)}$$

The deviation is 5 kHz by design, and the values for R1 are 170 kilohms ($f_0 = 82.5$ kHz) and 191 kilohms ($f_0 = 92.5$ kHz).

While the equation for computing the loop-damping factor associated with C1 is complex, there is a convenient rule of thumb. The damping factor should be approximately $\frac{1}{2}$, and a value of $C1 = C0/4$ will produce this. With C0 equal to $0.001 \mu\text{F}$, C1 equals 250 pf (picofarads).

Resistor Rb provides positive feedback across the FSK comparator and facilitates rapid transition between output logic states. A value of 510 kilohms is used in most applications.

Cf and Rf form a single-pole post-detection filter for the FSK data output. Rf is most often set at 100 kilohms. Cf smooths the data output; its value is roughly calculated: $Cf = (3/\text{data rate in bits per second})$ where Cf is in microfarads. Because this modem is designed for operation at 1200 bps (bits per second), a value of $0.0022 \mu\text{F}$ or $0.0033 \mu\text{F}$ is acceptable.

The final area requiring calculation is the lock-detect section of the XR-2211, which is used here in a carrier-detect function. The open-collector lock-detect output, pin 6, is connected to the data output, pin 7. This will disable any output created by noise unless a carrier signal is present within the detection pass-band of the PLL. Presuming a parallel resistance of 470 kilohms, the minimum value of the lock-detect filter capacitor, Cd, is $16/(f_1 - f_2)/2$. In this case $0.005 \mu\text{F}$ is adequate.

Testing the Completed Unit

I built the complete Circuit Cellar carrier-current modem the way shown in figure 3, with component values for 80/85 kHz and 90/95 kHz tone pairs, but you may substitute other values as previously discussed. In addition to the three functional sections we have looked at, I have added a carrier-detect indicator and

an RS-232C driver (IC3) and receiver (IC4).

To test the completed unit you need some source of serial data output. (I used a full-duplex video terminal.) The easiest test is a simple loop-back circuit. The terminal is connected to the originate modem and plugged into the power line. The answer modem is plugged in some distance away, with pins 2 and 3 jumpered together on J1, its RS-232C connector. As you type on the terminal, the data is transmitted to the answer modem where it is looped back through the jumper and retransmitted to the originate modem where it appears on the terminal's screen.

You should be able to place the modems anywhere within your home or office, or even an adjacent home or apartment. The ultimate range is limited by the power company's step-down transformer and the cross-coupling between the two 115-V legs of a multiphase 230-V distribution system. But you can arrange communication between the latter by attaching a fused capacitor between the two 115-V legs.

In Conclusion

Using this modem I was able to successfully communicate at 1200 bps for extended periods of time without loss of data. I've found FSK carrier-current communication to be fairly reliable; it's best at the lower data rates. Occasionally a few characters have been lost when my air-conditioner compressor or water pump turned on. These are occasions where an intelligent control system might be of significant help. I had intended that the intelligence necessary for error checking and redundant transmissions be part of this project, but as I explained, such a control system is much more involved than the modem itself. Given the excess computing power available in most personal computers, it would certainly be feasible in most cases for error-checking to be performed by applications software, perhaps using something like the well-known file-transfer protocol developed by Ward Christensen for use with his CP/M-based Modem-7 program.

Generally speaking, while I have detailed the hardware components of a complete system that works in the Circuit Cellar, it's important to recognize that AC line conditions differ significantly between locations. Complete frequency bands may be unusable due to interference produced by machinery, digital clocks, microcomputers, and fluorescent lights. For this reason, you should understand how the modem components and coupler are designed. Your ability to customize a basic modem design to the particular electrical environment of your home or office can make or break the project.

Next Month:

Build a digital video camera. ■

References

1. *Applications Data Book*. Sunnyvale, CA: Exar Integrated Systems Inc., 1981.
2. Ciarcia, Steve. "Build the ECM-103, an Originate/Answer Modem." March 1983 BYTE, page 26.
3. Ciarcia, Steve. "Come Upstairs and Be Respectable." May 1977 BYTE, page 50.
4. Ciarcia, Steve. "Tune In and Turn On: A Computerized Wireless AC Control System." Part 1, April 1978 BYTE, page 114. Part 2, May 1978 BYTE, page 97.
5. Edward, Harry J., Jr. *Residential Electrical Wiring: A Practical Guide to Electrical Wiring Practices in Residences*. Reston, VA: Reston Publishing Company, 1982.

Editor's Note: Steve often refers to previous Circuit Cellar articles as reference material for each month's current article. Most of these past articles are available in reprint books from BYTE Books, McGraw-Hill Book Company, POB 408; Hightstown, NJ 08250.

Ciarcia's Circuit Cellar, Volume I covers articles that appeared in BYTE from September 1977 through November 1978. Ciarcia's Circuit Cellar, Volume II contains articles from December 1978 through June 1980. Ciarcia's Circuit Cellar, Volume III contains the articles that were published from July 1980 through December 1981.

Steve Ciarcia (POB 582, Glastonbury, CT 06033) is an electronics engineer and computer consultant with experience in process control, digital design, nuclear instrumentation, product development, and marketing. In addition to writing for BYTE, he has published several books.

To receive a complete list of Ciarcia Circuit Cellar project kits available from the Micromint, circle 100 on the reader service inquiry card at the back of the magazine.

Introducing the Most Powerful Business Software Ever!

TRS-80™ (Model I, II, III, or 16) • APPLE™ • IBM™ • OSBORNE™ • CP/M™ • XEROX™

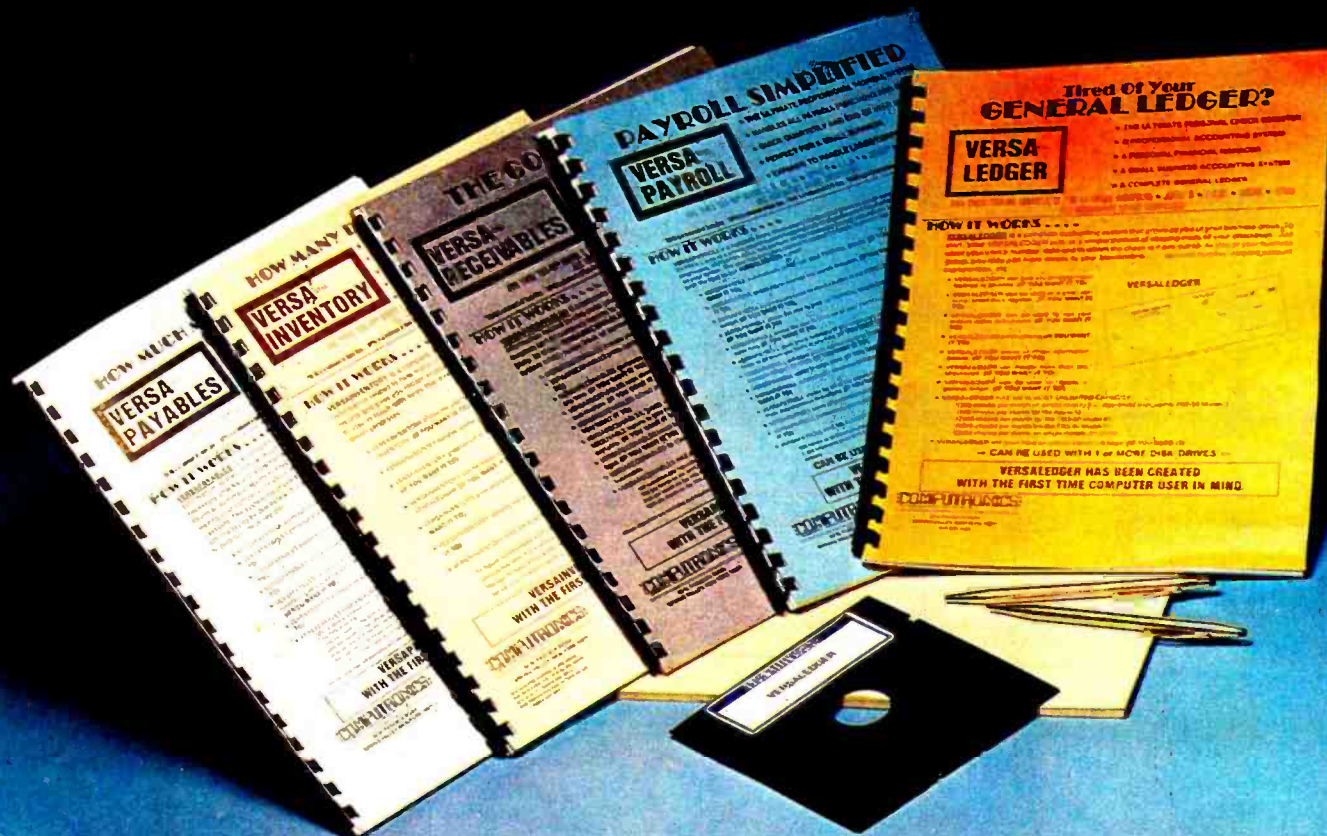

The VERSABUSINESS™ Series

Each VERSABUSINESS module can be purchased and used independently, or can be linked in any combination to form a complete, coordinated business system.

VERSARECEIVABLES™

\$99.95

VERSARECEIVABLES™ is a complete menu-driven accounts receivable, invoicing, and monthly statement-generating system. It keeps track of all information related to who owes you or your company money, and can provide automatic billing for past due accounts. VERSARECEIVABLES™ prints all necessary statements, invoices, and summary reports and can be linked with VERSALEDGER II™ and VERSAINVENTORY™.

VERSAPAYABLES™

\$99.95

VERSAPAYABLES™ is designed to keep track of current and aged payables, keeping you in touch with all information regarding how much money your company owes, and to whom. VERSAPAYABLES™ maintains a complete record on each vendor, prints checks, check registers, vouchers, transaction reports, aged payables reports, vendor reports, and more. With VERSAPAYABLES™, you can even let your computer automatically select which vouchers are to be paid.

VERSAPAYROLL™

\$99.95

VERSAPAYROLL™ is a powerful and sophisticated, but easy to use payroll system that keeps track of all government-required payroll information. Complete employee records are maintained, and all necessary payroll calculations are performed automatically, with totals displayed on screen for operator approval. A payroll can be run totally, automatically, or the operator can intervene to prevent a check from being printed, or to alter information on it. If desired, totals may be posted to the VERSALEDGER II™ system.

VERSAINVENTORY™

\$99.95

VERSAINVENTORY™ is a complete inventory control system that gives you instant access to data on any item. VERSAINVENTORY™ keeps track of all information related to what items are in stock, out of stock, on backorder, etc., stores sales and pricing data, alerts you when an item falls below a preset reorder point, and allows you to enter and print invoices directly or to link with the VERSARECEIVABLES™ system. VERSAINVENTORY™ prints all needed inventory listings, reports of items below reorder point, inventory value reports, period and year-to-date sales reports, price lists, inventory checklists, etc.

VERSALEDGER II™

\$149.95

VERSALEDGER II™ is a complete accounting system that grows as your business grows. VERSALEDGER II™ can be used as a simple personal checkbook register, expanded to a small business bookkeeping system or developed into a large corporate general ledger system without any additional software.

- VERSALEDGER II™ gives you almost unlimited storage capacity (300 to 10,000 entries per month, depending on the system),
- stores all check and general ledger information forever,
- prints tractor-feed checks,
- handles multiple checkbooks and general ledgers,
- prints 17 customized accounting reports including check registers, balance sheets, income statements, transaction reports, account listings, etc.

VERSALEDGER II™ comes with a professionally-written 160 page manual designed for first-time users. The VERSALEDGER II™ manual will help you become quickly familiar with VERSALEDGER II™, using complete sample data files supplied on diskette and more than 50 pages of sample printouts.

COMPUTRONICS

50 N. PASCACK ROAD, SPRING VALLEY, N.Y. 10977

SATISFACTION GUARANTEED!

Every VERSABUSINESS™ module is guaranteed to outperform all other competitive systems, and at a fraction of their cost. If you are not satisfied with any VERSABUSINESS™ module, you may return it within 30 days for a refund. Manuals for any VERSABUSINESS™ module may be purchased for \$25 each, credited toward a later purchase of that module.

To Order:

Write or call Toll-free (800) 431-2818
(N.Y.S. residents call 914-425-1535)

- * add \$3 for shipping in UPS areas
- * add \$4 for C.O.D. or non-UPS areas

- * add \$5 to CANADA or MEXICO
- * add proper postage elsewhere

Circle 480 on inquiry card.

DEALER INQUIRIES WELCOME

All prices and specifications subject to change / Delivery subject to availability.

* TRS-80 is a trademark of the Radio Shack Division of Tandy Corp. * APPLE is a trademark of Apple Corp. * IBM is a trademark of IBM Corp. * OSBORNE is a trademark of Osborne Corp. * CP/M is a trademark of Digital Research. * XEROX is a trademark of Xerox Corp.

www.americanradiohistory.com

**Rana's disk drive was
twice as good as Apple's
with one head.**

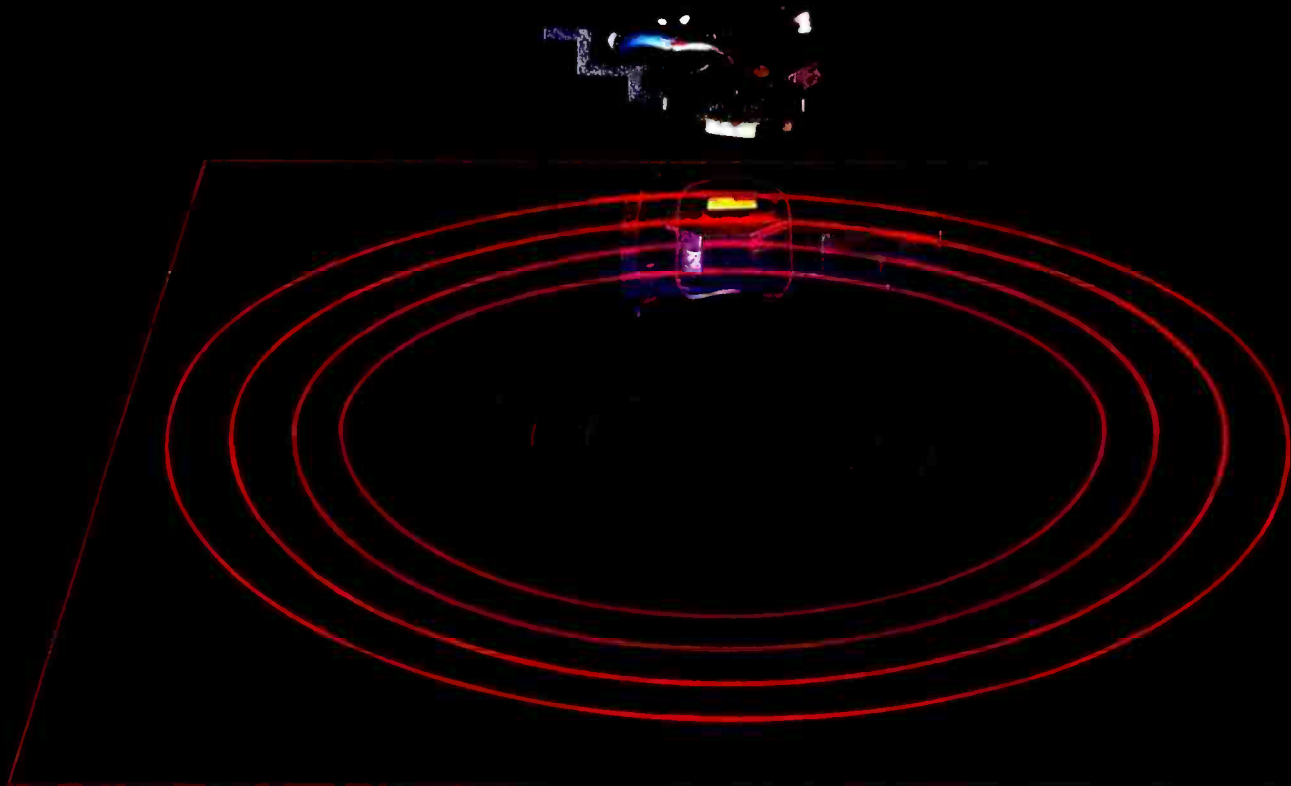

Now we have two.

We added another head so you won't have to buy another disk.

That's the beauty of a double sided head. A floppy disk which allows you to read and write on both sides. For more storage, for more information, for keeping larger records,

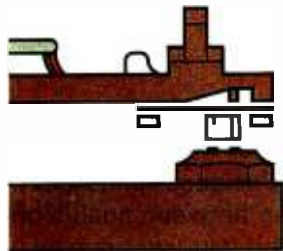

Rana's double sided heads give Apple II superior disk performance power than second generation personal computers such as IBM's.

and for improved performance of your system. That's what our new Elite Two and Elite Three offers. It's the first double headed Apple® compatible disk drive in the industry. And of course, the technology is from Rana. We're the company who gave you 163K

bytes of storage with our Elite One, a 14% increase over Apple's. And now with our high tech double sided heads, our Elite Two and Three offers you two to four times more storage than Apple's. That's really taking a byte out of the competition.

We put our heads together to give you a superior disk drive.

We designed the Elite Three to give you near hard disk capacity, with all the advantages of a minifloppy system. The double sided head operates on 80 tracks per side, giving you a capacity of 652K bytes. It would take 4½ Apples to give you that. And cost you three times our Elite Three's reasonable \$849 pricetag.

It takes 4½ Apples to equal the capacity of our superior Elite Three.



The Elite Two offers an impressive 326K bytes and 40 tracks on each side. This drive is making a real hit with users who need extra storage, but don't require top-of-the-line capacity. Costwise, it takes 2½ Apple drives to equal the performance of our Elite Two. And twice as many diskettes. Leave it to Rana to produce the most cost efficient disk drive in the world.

We've always had the guts to be a leader.

Our double sided head may be an industry first for Apple computers, but nobody was surprised.

© Apple is a registered trademark of Apple Computer, Inc.



They've come to expect it from us. Because Rana has always been a leader. We were the first with a write protect feature, increased capacity,

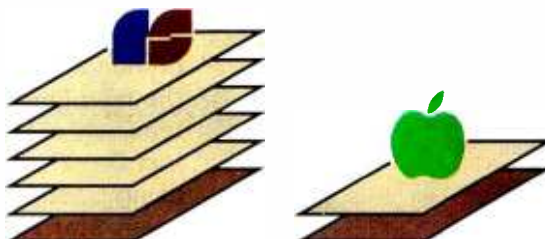

Your word processor stores 5 times as many pages of text on an Elite Three diskette as the cost ineffective Apple.

and accurate head positioning. A first with attractive styling, faster access time, and the convenience of storing a lot more pages on far fewer diskettes. We were first to bring high technology to a higher level of quality.

So ask for an Elite One, Two, or Three. Because when it comes to disk drives, nobody uses their head like Rana.

NOW AVAILABLE FOR THE APPLE III. . .
THE ELITE TWO.THREE AND ELITE THREE.THREE

RanaSystems



21300 Superior St., Chatsworth, CA 91311 (213) 709-5484. For dealer information call toll free: 1-800-421-2207. In California only call: 1-800-262-1221. Source Number: TCT-654

Circle 337 on inquiry card.

Available at all participating Computerland stores and other fine computer dealers.



THE

The C language provides a new standard for portability in a computer world characterized by a plethora of processors. Designed to make programs portable, fast, and compact, C fills a niche between such high-level languages as BASIC, COBOL, and Pascal and low-level assembly languages tied to particular processors. Perhaps most aptly described as a "medium-level" programming language, C is a powerful tool in the hands of professional programmers.

Most major microcomputer manufacturers and software developers use C for writing systems programs—operating systems, utilities, languages, and applications. Digital Research is writing all of its new products in C, including CP/M-68K for the 68000 microprocessor and the new Personal BASIC. Both Microsoft and Visicorp have used C extensively in products ranging from Multiplan and Xenix to Visiword and Visi On. The computer graphics sequences in *Star Trek II* were created using C, and Lucasfilm Ltd. used C for computer-aided animation in the latest Star Wars saga, *Return of the Jedi*.

Why is C so popular? The primary reason is that it allows programmers to easily transport programs from one computer or operating system to another while taking advantage of the specific features of the microprocessor in use. And C is at home with systems from 8-bit microcomputers to the Cray-1, the world's fastest computer. As a result, C has been called a "portable assembly language," but it also includes many of the advanced structured-programming features found in languages like Pascal.

Our theme articles in this issue take a close look at the C language. Stephen Johnson and Brian Kernighan of Bell Laboratories present an overview of C and compare it with other computer languages in "The C Language and Models for Systems Programming." James Joyce offers a guided tour of C's key features, along with programs that illustrate C programming concepts and style, in the first of a two-part series, "A C Language Primer."

C is a concise language that has a small kernel of 30 reserved words, and its input/output specifics are gathered into a library of standard functions. That means the language can be brought up easily on new microprocessors, resulting in dozens of versions of C. We sampled a few of these for the most popular operating systems.

Most applications programs are becoming large and complex in order

LANG



C

that new users perceive them as easy to use. Jason Linhart discusses how to choose a suitable computer language for "Managing Software Development with C."

Not surprisingly, the largest number of C languages, and some of the most advanced, are available for the highly regarded IBM Personal Computer. Most of the C compilers for the IBM PC are also available for the MS-DOS operating system, on which the IBM PC-DOS is based. These are reviewed by Ralph Phraner in "Nine C Compilers for the IBM Personal Computer."

The CP/M-86 operating system has a wealth of C compilers as well. Authors Jerry Houston, Jim Brodrick, and Les Kent take a look at the first of those available in "Comparing C Compilers for CP/M-86." Christopher Kern reviews "Five C Compilers for CP/M-80." C has been available for CP/M-80 for a while, and as a result a strong C users' group and several volumes of public-domain software exist.

No discussion of C is complete without mentioning the Unix operating system, which is written in C. Unix and its utilities comprise over 300,000 lines of C source code, certainly the most ambitious C project yet. Developed more than 10 years ago at Bell Laboratories, both Unix and C are now coming into widespread use. To round out our coverage of C, in this issue we begin "The Unix Tutorial," a series of articles on the Unix operating system. Part 1 is an overview of Unix and its features along with a short history of how C and Unix were developed. Together, C and Unix provide one of the most comfortable working environments for professional programmers. A text box by Walter Zintz describes Unix and C resources.

Both the C language and the Unix operating system are based on modularity and short, general-purpose routines, a subject Rebecca Thomas explores in "What Is a Software Tool?" "The Unix C Compiler in a CP/M Environment" by Matthew Halfant looks at some of the issues and ambiguities involved in moving C programs between these two popular operating systems.

An annotated bibliography of C on page 268 lists the books and articles on C that have been published in the past few years.

C is relatively young for a computer language, but it is appropriate that, in its 10th anniversary year, C is being recognized as the powerful language for professionals that it is.

—Bruce Roberts



LANGUAGE

The C Language and Models for Systems Programming

A compromise between assemblers and high-level languages, C helps programmers avoid the idiosyncrasies of particular machines

by Stephen C. Johnson and Brian W. Kernighan

The C language was created at Bell Laboratories by Dennis Ritchie in 1972. One of its first uses was to rewrite the Unix operating system, previously written in PDP-11 assembly language. In its early years, C was used to write other critical systems programs as well: compilers, parser generators, document formatters, and editors, to name a few. At the time, using a high-level language for such applications was a radical departure from standard practice; everyone knew that these programs had to be written in assembly language "for efficiency." Yet in many cases the C code, although clearly less efficient in any given routine, produced programs that outperformed similar programs written in assembly language.

A key to understanding the philosophy behind C is the notion of a model for the problem to be solved. Rather than try to deal with all of reality in every line of code, programming languages, explicitly or implicitly, construct models of reality and present them to the programmer. In assembly language, for example, part of the language model is that the programmer need not be concerned with the actual memory location of the variables; they can be referred to by names like `start` or `count`. This simplification makes it far easier to program in assembly language than to write the binary bits that actually control the processor. The assembly-language model does, however, leave the allocation of registers and the choice of machine instructions to the user.

BASIC provides another model, similar to that of a very good programmable calculator. For many purposes, BASIC programmers do not have to worry about the details of where variables are stored, how arithmetic is

done, or how to format output. As a result, BASIC is much easier to use than an assembly language.

The Smalltalk system supports a very different model. The Smalltalk programmer manipulates *objects* whose physical locations are invisible to the user, as are the details of the object's creation, manipulation, and internal structure. This model leads to a very different style of use; for example, rather than calling a routine to print an object, a Smalltalk user sends a message to the object telling it to print itself.

High-level models like the one supported by Smalltalk tend to be easy to use (provided that the model supports what we want to do) but are often less efficient than low-level ones. The hardware support for some of these models, especially on microcomputers, is not very good; we may sacrifice efficiency for ease of use. In systems code, efficiency is often very important, so the use of high-level models may be impractical. On the other hand, the low-level model presented by assembly language is not ideal either. In an assembly language, the details of the machine being programmed are implicit in every line: how many registers it has, how it uses its stack, how the I/O (input/output) is done. Not only is assembly code too firmly attached to a particular computer and system, it is also harder to write because the model supplied to us, with its registers and branches, is too far from the application we are trying to write.

The C Model

C offers a compromise. It makes available a basic model that is very close to the target machine, enabling

Super5

The Finest Quality Products for Apple® and IBM

The *Super5* stands alone in fine quality and workmanship.



Super5 -CP80

- 640 dots/line. High density, high quality character.
- Bit image graphic.
- 40, 71, 80, 142 columns.
- Adjustable sprocket pin. feed plus friction feed.
- Cartridge ribbon.
- Standard centronics parallel. Optional RS232C.

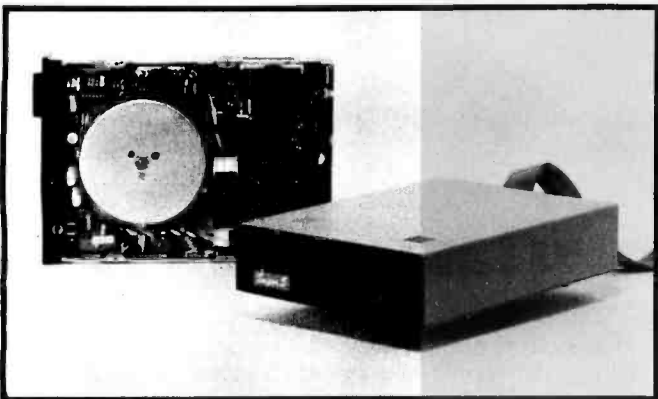

Super 5 has the following advantages compared to the normal floppy disk drive:

Characteristics	Super 5 - T40	Normal Type
Servo motor/Spindle connection	Direct shaft drive	Belt drive
Head positioning mechanism	Metal band positioner	Plastic CAM positioner
Track to track time	Approx. 3-6 msec.	Approx. 40 msec.
Write-protected sensor	Photo coupler	Mechanical switch
No. of tracks	40 tracks	35 tracks

SUPER5-T40 single sided, direct shaft drive
 SUPER5-T80 double sided, direct shaft drive
 T40 drive control card: suitable for 35, 40 tracks drive
 T80 drive control card: suitable for 35, 40, 80 tracks drive

Mitsuba Corporation

667 Brea Canyon Rd., #25
 Walnut, CA 91789

Tel.: (714) 594-6959

Japan: EI-EN Ent. TLX J23325

Taiwan: GIFU Ent. TEL (02) 752-9661

Hong Kong: A&N Ent. TEL 5-488463

us to write efficient code where necessary. At the same time it provides powerful mechanisms for building our own models, so that much of the coding can be done at a more comfortable level, safely removed from the idiosyncrasies of any particular computer.

Most computers have dozens of different operation codes; because C tries to get close to the target hardware, it has dozens of operators. This feature makes C slightly harder to read (or, more properly, to learn) because, in addition to the usual arithmetic operators, there are operators for such common instructions as ++ (increment), -- (decrement), and << and >> (left and right shift) as well as logical AND, OR, exclusive OR, and one's complement (&, |, ^, and ~). The reward for learning the operators is that programmers can state their intentions clearly and naturally and be assured of a direct translation into suitable machine instructions.

In C the basic data types include bytes, short integers, long integers, and single- and double-precision floating-point numbers. C also supports pointers to other data.

For systems programming, it is often vital to manipulate bits efficiently, for example, to control I/O devices, displays, and other hardware. Such tasks are easy in C because of its bit-manipulation operators. But in BASIC, FORTRAN, or Pascal, the bitwise operators do not exist—they are not part of the model. The only recourse in those languages is a painful emulation or the use of an efficient function call.

The model of data in C is also very rich. The basic data types include bytes, short integers (typically 16 bits), long integers (typically 32 bits), unsigned versions of these, and single- and double-precision floating-point numbers. C also supports the notion of pointers to other data; these pointers correspond to machine addresses. Because most hardware instructions deal directly with such addresses, the support of pointers encourages generation of extremely efficient code for critical program segments and the building and manipulation of very efficient data structures.

Pointer Operations

The model of pointers supported in C includes the standard operations of taking the address of an object (&object) and accessing the object pointed to by a pointer (*p). For example, suppose that x is an integer and p is a pointer to an integer. (There is no such thing as just "a pointer"; it is always a pointer to a particular data type.) Then

```
x = 3;           /* set x to 3 (what else?) */
p = &x;         /* set p to address of x */
```

The content of p is the address of x; the value pointed

WHAT GOOD IS A COMPUTER THAT'S FASTER THAN EINSTEIN IF YOUR FORMS SUPPLIER IS SLOWER THAN GUTENBERG?

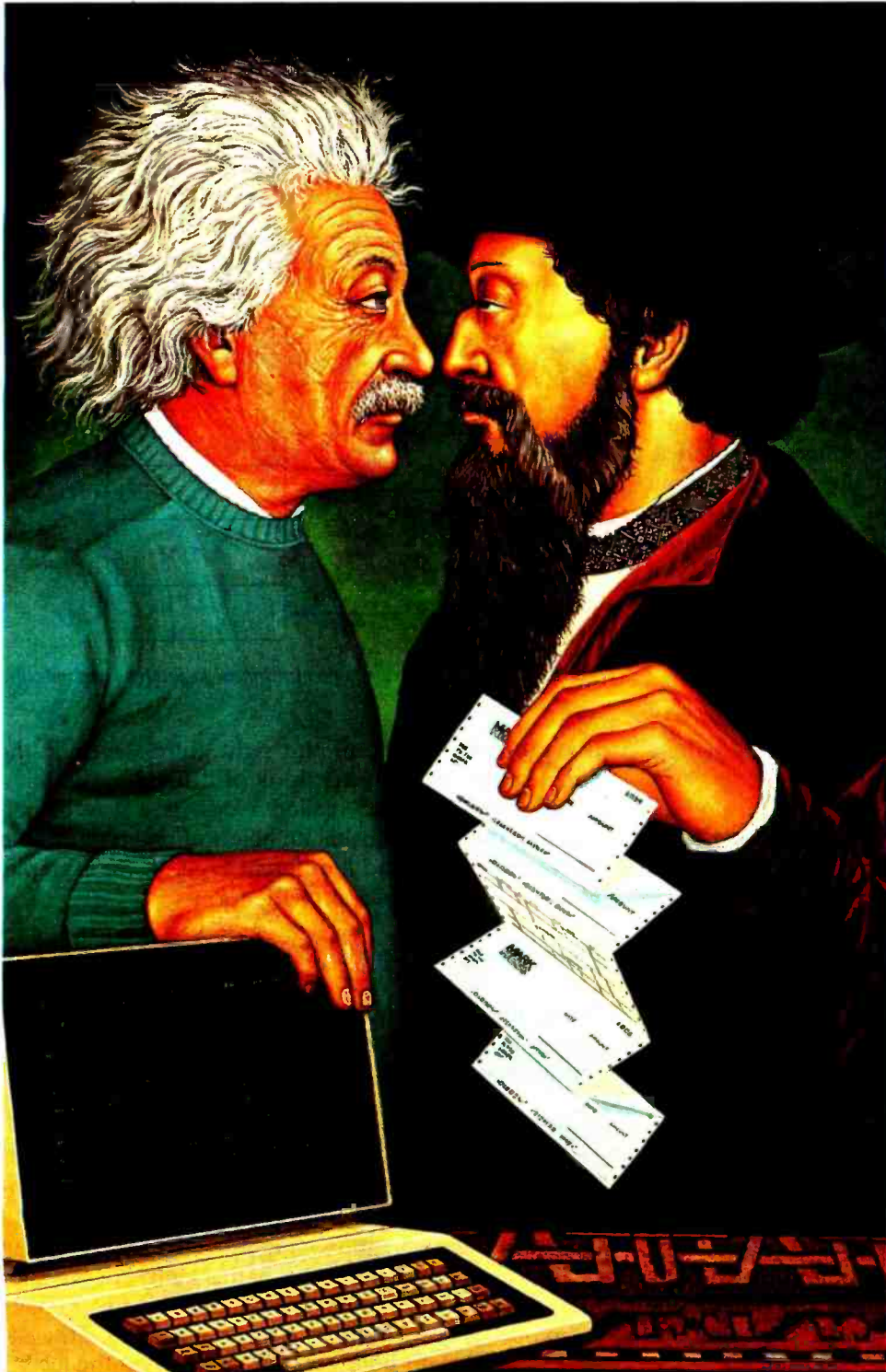

Unlike our major competitors, Deluxe gives you a 3-day in-plant turnaround on standard computer forms. Even on small quantities of 500 or more.

What's more, we can match all popular software formats for your checks, invoices and statements.

We'll even customize forms for your own programs with a 5-day in-plant turnaround, and lots of ink colors and free logo designs to choose from.

And if you're not satisfied with any Deluxe form, simply return it within 30 days for a prompt refund.

We have a free full color catalog for you, too. It features computer forms, supplies and accessories.

With it, you can order the materials you need to keep up with your business.

And the forms you need to keep up with your computer.

See your local banker, or call toll free:

1-800-228-2606.

(In Nebraska: 1-800-642-8777.)

FREE FULL COLOR CATALOG.



Just send in this coupon for our full color catalog featuring computer forms, supplies and accessories.

Deluxe Computer Forms, 530 North Wheeler, P.O. Box 43046, St. Paul, Minnesota 55164-0046

Name

Company

Address

City

State Zip

Phone ()

DELUXE
COMPUTER FORMS

7154

to by `p` is written `*p`. Thus, in this case, `*p` is 3. Conversely, `*p` can be used to set the value of `x`:

```
*p = 4;          /* x is now 4 */
```

It is also possible to use the value of the pointer itself: if `q` is also a pointer to an integer, then the statement

```
q = p;          /* make q point to whatever p points to */
```

gives `q` the same value as `p`, so `q` also points to `x`. Figure 1 illustrates this operation.

Beyond this capability, which is more or less what Pascal provides, C includes the ability to manipulate pointers in ways that depend on what they are pointing to. For example, if we have a pointer to a byte, and increment it, it points to the next byte; if we have a pointer to a 16-bit integer and increment it, it points to the next integer (2 bytes away). Pointers are an excellent way to do array indexing, as shown in figure 2, where `x` is an array of integers.

In contrast to the pointer capabilities of C, FORTRAN and BASIC have a restricted model that does not include pointers. In Pascal, pointers are dynamic objects that can be set only by calling the storage allocation function `new`. Pascal does not allow pointer arithmetic.

Another use of pointers in C is to associate an address with a device. Most BASIC programmers are used to PEEK and POKE statements sprinkled liberally throughout their programs to access memory locations that control devices. In C, pointers achieve the same effect without the need to add a new pair of functions. In BASIC, you set a memory location by a sequence such as

```
100 V = 36828
...
800 POKE(V, 15)
```

In C, the same code might be written as

```
sound_vol = 36828;    /* sound generator volume address */
...
*sound_vol = 15;     /* set sound generator volume */
```

With the freedom implicit in C's use of pointers come certain risks. Much of C's growth over the last decade has been in ways of detecting erroneous uses of pointers without restricting the ability to write efficient code when necessary.

Casts

Operating systems have to deal with some very unusual objects and events: interrupts; memory maps; apparent locations in memory that really represent devices, hardware traps and faults; and I/O controllers. It is unlikely that even a low-level model can adequately support all of these notions or new ones that come along in the future. So a key idea in C is that the language model be flexible, with escape hatches to allow

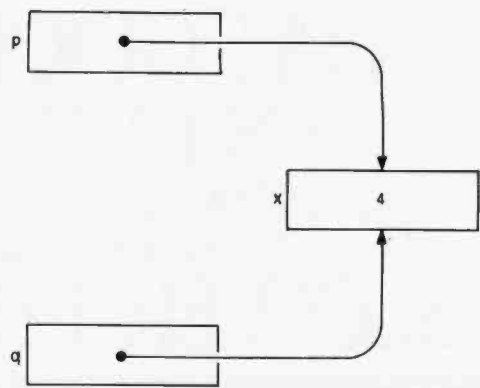

Figure 1: If pointer `p` points to location `x`, then the statement `q=p` makes `q` point to `x` also.

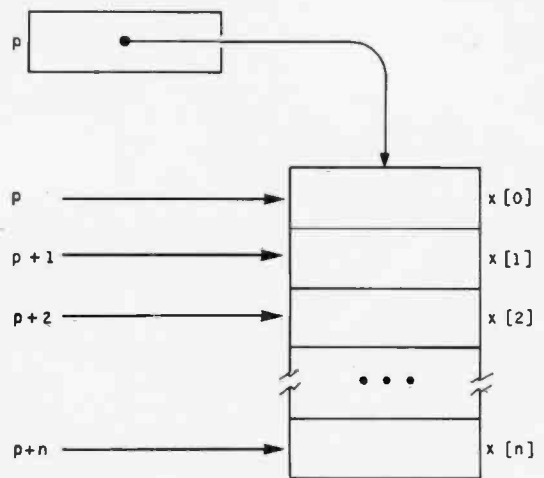

Figure 2: The ability to do pointer arithmetic facilitates array indexing.

the programmer to do the right thing, even if the language designer didn't think of it first.

One such construct, called a *cast*, is a way of persuading the compiler that an object of one type should be treated as if it had a different type. If, for example, you write an expression of the form

(type-name) expression

the result is the value of *expression* as an object of type *type-name*. For some combinations, this causes a new representation to be computed, as in

(float) integer expression

but sometimes it simply means that the bits in the expression are to be treated as a different type without a change in representation.

Casts involving pointers are of this kind. Suppose, for example, that you want to test whether a pointer points to an odd or even address. It is not legal to use the bitwise operators on pointers, but you can do the job by

IBM® + GENIE™ = Solution

5.25" Fixed/Removable Winchester Cartridge Drive Systems For The IBM Personal Computer/Compatibles



5+5™



=



● The Genie Cartridge Drive

A revolutionary new 10 Megabyte Hard Disk Drive that includes a 5 Megabyte removable hard disk cartridge. The cartridge drive system simply plugs into your computer, and includes all necessary software and hardware. Genie Drives are compatible with most popular software, and each cartridge replaces over 30 double-density floppy disks.

● 5.25" Removable Cartridge

(Proposed ANSI Standard). Imagine, 5 Megabytes in the palm of your hand. These small Winchester cartridges are only .75 inches thick and 5.50 inches square. The disk itself is completely sealed from the outside and all its hazards by a sliding door that opens only once the cartridge is firmly seated inside the drive.

- 10 MEGABYTES OF ON-LINE STORAGE
- FILE SIZES TO 5 MEGABYTES
- BACK-UP 5 MEGABYTES IN TWO MINUTES
- CARTRIDGE INTERCHANGEABILITY GUARANTEED

● Genie's Solution To Personal Computer Mass Storage Problems

Up until now, people with serious mass storage applications have had no realistic means of conveniently maintaining their large data bases due to the cost of storage media and the expense and inefficiencies of doing back-ups. The Genie systems approach solves such typical storage problems by allowing both high capacity Fixed Drives and 5 Megabyte Removable Cartridge Drives to be intermixed on the same computer system. This provides the ultimate storage solution because of the new ease of doing back-ups, along with ability to maintain several large data bases on removable cartridges, eliminating the need to tie up expensive disk drives over a single data base application. With Genie Drives, the combinations are unlimited. Flexibility and versatility were key design considerations. A user can configure up to eight of our Drive Products in any combination to derive a storage solution for just about any application imaginable. With Genie, your personal computer can now take on tasks that had only been possible with mainframes.



MODEL X5A

X5™

Genie Systems Are Expandable Up To 160 Megabytes Using Any Combination Of Genie Drive Models

- 5 MEGABYTES OF ON-LINE STORAGE
- FILE SIZES TO 5 MEGABYTES



MODEL X5P

SIMPLY PLUGS INTO YOUR I.B.M.



5-10-15-20

- USER CAN BACK-UP TO MODELS 5+5 OR X5 REMOVABLE CARTRIDGE DRIVES OR DISKETTES.

5 MEGABYTES
10 MEGABYTES
15 MEGABYTES
20 MEGABYTES

Manufacturer's suggested retail price. Includes all required components.

CP/M-86 and Concurrent CP/M-86 is a registered trademark of Digital Research.

IBM is a registered trademark of IBM Corporation.

Dysan is a registered trademark of Dysan Corporation.

UCSD P System is a registered trademark of the Regents of the University of California San Diego.

QNX is a registered trademark of Quantum Software System, Inc.

Etherlink is a registered trademark of 3Com Corporation.

Ethernet is a registered trademark of Xerox Corporation.

TALK ABOUT USER FRIENDLY...
3Com Ethershare™ Compatible (Ethernet Standard)

- IBM XT Compatible
- Automatic Install (Genie Custom BIOS)
- Comprehensive menu driven utility package
- Intermix different operating systems on disk or cartridge
- Assign to any drive codes from A thru H
- Choice of volume sizes
- Give your virtual volumes 16 character names
- Assign command allows you to assign 8 virtual drives on line at any one time
- Show command allows instantaneous viewing of all virtual drives on line
- Help command displays syntax for all new commands
- User can back up to or from any model Genie Drive
- File sizes 5-20 megabytes, dependent upon drive type.
- Automatic recovery system
- Easy back ups in minutes
- Cartridges can have 16 character names
- System status screen messages
- System expandable to eight drives using only one slot in your IBM PC
- Built-in error detection and correction
- No preventative maintenance required
- Power-on self test
- Create turnkey systems
- Ultra hi-speed DMA data transfers
- Comes complete with all necessary software and hardware
- Operating systems supported: IBM DOS 1.1, 2.0, CONCURRENT CP/M 86®, CP/M 86®, UCSD P SYSTEM®, QNX™

AVAILABLE AT YOUR LOCAL COMPUTER DEALER

GENIE COMPUTER CORPORATION

31131 Via Colinas #607 • Westlake Village, CA 91362 • (213) 991-6210 • TLX 658233 (GENIE USA)

The Best In Price, Selection and Delivery

Professional Quality

Call Now TOLL FREE

800-368-3404

(In VA, Call Collect 703-237-8695)

AMPEX • INTERTEC • TEXAS INSTRUMENTS • GENERAL DATA COMM. • ANDERSON JACOBSON • C. ITOH • QUME • BEEHIVE • DATASOUTH • DIABLO • CENTRONICS • NEC • PRENTICE

MICROS

INTERTEC SUPERBRAIN II

64K DD* \$1874
 64K QD* \$2249
 64K SD* (96TPI) \$2689

*Includes M/Soft BASIC
DYNABYTE 8/16 BIT Call
Callan 16/32 BIT Call

PRINTERS

NEC

7710 Ser. \$2089
 7715 \$2099
 7730 Par. \$2099
 7720 \$2449
 7725 \$2496
 Std. Tractor 77xx \$ 199
 3510 \$1390
 3515 \$1424
 3530 \$1390
 3550 (IBM) \$1869
 3520 \$1979
 3525 \$1999

DATASOUTH ED180 Call

DATASOUTH ED220 Call

DIABLO

620-SPI \$ 889
 630-R102/147 \$1949
 630 ECS \$2389
 630-R155 \$1709
 *(for IBM PC, Apple II, TRS-80)

630K104 (KSR) \$2265

QUME

Sprint 9/45 FP \$1794
 Sprint 9/55 FP \$2119
 Sprint 9/55 FP/SMEM \$2186
 Sprint 9/55 LP/XMEM \$2094
 Sprint 11/40-PLUS \$1449
 Bi-Dir Forms Tractor \$ 199
CENTRONICS: 122 (p) \$ 689
 High Speed Line Printers Call

TERMINALS

AMPEX

D80 \$1589
 PHAZE (3270 EM.) \$1589

BEEHIVE (SMART DISPLAY)

DM5 Call
 DM5A Call
 DM83 (Burroughs) Call
 DM3270 (3270 Emulator) Call
 Protocol Converter Call

QUME

QVT-102 \$ 549
 QVT-108 Call

C. ITOH

CIT 101 \$1289
 CIT 161 (64 Colors) Call
 CIT 201 (Graphics for
 TEK 4010/4014) Call

CIT 414 (Graphics
 640 x 480 Res.) Call

TEXAS INSTRUMENTS

745 Standard \$1172
 745 Std. (Reconditioned) Call
 765 Bbl M/my Call
 785/787 Call
 810 Basic \$1249
 810 Package \$1439
 820 Package RO \$1610
 820 KSR Package Call
 703 Std. \$ 459
 707 KSR \$ 549
 850 Tractor Feed \$ 549

MODEMS

PRENTICE STAR 300 Bd. \$ 124
 U.S. Rob Auto Dial 212A \$ 469
 Stat Muxes Call
 Ventel 212 + 3E Call
 GDC 24/9600 Bd. Call
 Prentice 24/9000 Bd. Call

DISC DRIVES

QUME

Data Trak 5 \$ 289 or 2 for \$ 549
 Data Trak 8 \$ 519 or 2 for \$ 999

SOFTWARE

BISYNC-3780 \$ 769
 WordStar \$ 279
 Data Star \$ 218
 Mail Merge \$ 144
 Spell Star \$ 144
 Plan 80 \$ 249
 d Base II \$ 489
 CalcStar \$ 191
 SuperSort \$ 158
 Super Calc \$ 144
 InfoStar \$ 279
 CIS Cobol \$ 689
 Forms II \$ 159
 MACRO 80 \$ 183
 "C" Compiler \$ 239
 Term II \$ 189

WordStar Professional
 (WS, SS, MM, SI) \$ 399

ReportStar \$ 199
 StarIndex \$ 129
 PlanStar Call
 StarBurst Call
 InfoStar Plus Call

IBM PC

256K RAM Bd. \$ 256
 256K RAM db/Full Parity \$ 305
 CP/M-Z80 CO-PROC. \$ 495
 Baby Blue \$ 600
 Baby TEX \$ 600
 Baby TALK 8270 BISYNC \$ 895
 8" Disk Controller \$ 395

In addition, we can make EIA RS 232 or RS 449 cables to your order, and supply you with ribbons, printer stands, print wheels, thimbles for all printers listed. And many, many more items. CALL NOW.

All items shipped freight collect either motor freight or UPS unless otherwise specified. All prices already include 3% cash discount. Purchase with credit card does not include discount. Virginia residents, add 4% Sales Tax. For fastest delivery send certified check, money order or bank-wire transfer. Sorry, no C.O.D. orders. All equipment is in factory cartons with manufacturers warranty (honored at our depot). Prices subject to change without notice. Most items in stock.



TERMINALS TERRIFIC

Terminals Terrific, Inc., P.O. Box 216, Merrifield, VA 22116
 Phone: 800-368-3404 (In VA, Call Collect 703-237-8695)

casting a pointer to an integer and then testing the low-order bit with a logical and operator:

```
if ((int)p & 1)
    { ... pointer is odd }
else
    { ... pointer is even }
```

The cast (int)p changes the interpretation of the pointer p without changing its value.

A very similar example is the mechanism used with the standard storage allocator. The C library function calloc is analogous to the Pascal new function; it returns a pointer to a block of storage. The pointer returned by calloc must be cast to the proper type:

```
pthing = (thing *) calloc(n, sizeof(thing));
```

This tells the compiler that the pointer returned by calloc may be safely regarded as a pointer to an object of the type thing.

Higher-Level Models

We need not be stuck with a machine-level model for long. C provides a number of ways by which we can extend the basic model to support data structures and operations important to our particular program. The two major ways to extend the model are by defining functions and making data structures, as a simple example illustrates. Suppose you are writing a video game and want to have a number of pictures moving around the screen. You could define a data structure that describes the objects using the struct mechanism of C; such a data structure might contain the x and y coordinates of the current picture, enough information to draw the picture on the screen, and other information of importance for the game (such as orientation, velocity, amount of fuel remaining, etc.). The declaration would look something like this:

```
struct picture {
    /* picture for display */
    int x, y; /* screen coordinates */
    float vel; /* velocity */
    float fuel; /* fuel remaining */
    disp_list *dl; /* display list to print it */
};
```

You can then declare variables of this composite type and build functions that provide basic operations on it. Depending on the game, you might supply functions to create, change, and destroy pictures, move them from one place to another, and decide whether two pictures collide. At this point, you will have effectively raised the level of the model in which you program from bits and bytes to picture manipulation. You can concentrate on the rules of the program rather than the implementation. Once you're comfortable with this style of programming, the nearly nonexistent model-building facilities of BASIC, say, become nearly intolerable.

Teletek's New Combo Could Make You A Hero!

The SBC-II could be just the right ingredient for your latest concoction. The newest member of Teletek's family of multi-user, multi-processing S-100 products, the SBC-II essentially combines, or "sandwiches" two Teletek SBC-I's into one board. The SBC-II provides the capability to support two users from one standard size IEEE-696/S-100 slave board.

The SBC-II maintains full performance for each user with an independent CPU (Z80A or Z80B), 64K RAM, Serial I/O, and FIFO communications port to the system master. The system integrator benefits by getting complete support for two users for the price of one board.

TurboDOS and MDZ operating systems will support combinations of SBC-I's and SBC-II's offering system design efficiency and flexibility never before possible.

If you're hungry for value and efficiency, order an SBC-II from Teletek. You'll love every byte.



TELETEK

4600 Pell Drive
Sacramento, CA 95838
(916) 920-4600
Telex 4991834 TELETEK
Dealer inquiries invited.

© Teletek 1983

Circle 385 on inquiry card.

Efficiency

Higher-level models have their drawbacks; you must pay for the function calls needed to do many of the basic operations on your pictures. Most C implementations try hard to make function calls efficient, but if you haven't skillfully chosen a model, the inefficiency may be painful. Especially in the earliest stages of program development, however, concern with efficiency may be misplaced. Why optimize a program when you are likely to decide tomorrow that it was all wrong and should be rewritten? The models are tailored to a particular program, so they may be readily adapted to improve efficiency without destroying the program's structure.

Although function calls and the use of a compiler language are somewhat inefficient, they have dramatic advantages. Algorithms and data structures expressed in a high-level language are comprehensible and thus more likely to be revised when a different good idea comes along. If they were written in an opaque, incomprehensible language, changes would be attempted rarely and successful even more rarely. Because real programs typically suffer a long series of changes and adaptations before a user ever sees them, being able to modify the algorithms and data structures quickly as the job changes leads to a better final product.

Another point about efficiency is worth mentioning. Many studies have shown that most programs spend 50 percent or more of their time in a very small portion (5 percent or so) of their code. This suggests that the 95

percent of the program that is noncritical should be as clear and easy to understand and change as possible. When it comes to the critical 5 percent, C lets the user get very close to the target machine in order to improve efficiency. Furthermore, many C environments contain measurement tools that enable the programmer to identify these critical sections easily. But the strategy is definitely: first make it work, then make it right, and, finally, make it fast.

Using functions to extend the base language also prevents C from becoming unwieldy. Many built-in features of other languages (notably I/O, string handling, and dynamic storage allocation) are supplied by function calls in C. This means that the model supplied by C itself is very flexible; it adapts to different operating systems and environments without suffering from a "one size fits all" philosophy. For example, the character-string operations appropriate for a text editor might be quite different than those for a spelling checker, and those in turn might differ from the operations needed in an operating system (where you might not need such operations and could not afford to have them loaded by default).

Portability

Using functions to extend the base language explains why a language that is so low level can be so portable. C compilers have been built for more than 40 different machines, from the Z80 to the Cray-1. The Unix system

Make your micro work like a mainframe.

First, neatly tape the "370" label onto your IBM Personal Computer.

Now slip a dBASE II™ disk into your main drive.

That's it: your IBM PC is now ready to run a relational database system, the kind IBM put on their mainframes last year.

And you're ready with more data handling power than you would have dreamed possible before dBASE II.

With a word or two, you *create* databases, *append* new data, *update*, *modify* and *replace* fields, records and entire databases. *Display* any information, *report* months worth of data in minutes and *zip* through input screens and output forms.

You can use it interactively for answers right now. Or save your instructions and repeat everything with two words: *do Manhours*, *do Project X*, *do whatever* has to be done.

To try dBASE II free for 30 days, drop by your local computer store. Or if they're sold out, call us at (213) 204-5570. If you don't like it, you get your money back.

But if you do that, you'll have to remove the label. Because nothing short of a mainframe works like dBASE II.



Ashton-Tate

© 1982 Ashton-Tate
CP/M is a trademark of Digital Research

dBASE II™ made better.

FOX & GELLER

"the products make the difference."

QUICKCODE MAKES IT EASY

No programming. That's what makes QUICKCODE, THE dBASE II program generator by Fox & Geller so easy to use. With QUICKCODE you can generate a customer database in 5 minutes or write concise programs for any type of database. QUICKCODE is the most powerful, easiest to operate program generator ever.

When you create a line of products that make dBASE II easier, more fun and faster to use you make dBASE II better. And that's exactly what Fox and Geller products are designed to do!

dGRAPH MAKES IT FUN

Fox & Geller combine database with graphics to create dGRAPH, the exciting new dBASE II graphics system. Imagine, you can actually teach your dBASE II to draw three different types of graphs. Think of the impact! Think of the fun!

dUTIL MAKES IT FAST

dUTIL is Fox & Geller's utility program for dBASE II. dUTIL combines your dBASE II command files to automatically produce a faster running time. A consistent favorite among dBASE II users.

Call us at (201) 794-8883

FOX & GELLER products make dBASE II even better!



FOX & GELLER

Fox & Geller, Inc. 604 Market Street Elmwood Park, N.J. 07407 (201) 794-8883

Circle 174 on inquiry card.

www.americanradiohistory.com



2 chips are better than one

Is your Apple's 6502 processor chip a little overworked lately? Have you been eyeing one of those new, 16-bit systems? But you don't want to give up all your Apple programs ...

Add the powerful 16-bit 8088 processor to your Apple with ALF's Processor Card. Let the 6502 and 8088 work together to tackle your toughest problems—like speeding up your Applesoft and Apple Pascal programs. With the Processor Card, you can use the CP/M™ 86 or MS-DOS™ operating system to run the latest 16-bit software, including many IBM PC programs.

64K or 128K of high-speed memory is available for ALF's Processor Card. Use the Processor Card with 128K as a fast disk emulator or to view sixteen hi-res images in under a second. Or run Basic, C, COBOL, or Pascal with 16-bit performance!

The ALF Processor Card is just \$395 (Applesoft speed-up software included). See your Apple dealer today, or contact ALF for more information.

Trademarks: "Apple": Apple Computer, "CP/M": Digital Research, "MS-DOS": Microsoft.

ALF

ALF Products Inc.
1315F Nelson St. Denver, CO 80215
(303) 234.0871 Telex: 4991824

has been moved to over a dozen machines, with new entries coming in weekly. All this from a language that won't even commit itself to the number of bits in a byte!

C programs are portable to the extent that the model they support is portable. A portable I/O library provides simple formatting and file-manipulation facilities. The model is so simple that it can be supported on most operating systems. If your application uses that model of I/O and you use the portable I/O library, then you will have no problem with I/O. Similarly, C provides models of data that can be supported on many different machines; if your program uses only the features of the basic model, your program is portable. Unfortunately, data restrictions show up as you move from machine to machine. The most unpleasant are the differences that are now entrenched in the industry as to the ordering of bytes in a word. The PDP-11 and many descendants, for example, store the bytes from low to high, while the IBM 370, Motorola 68000, and many others store the bytes from high to low. The size of an integer may vary from 16 bits on most microcomputers to 36 bits or more on some of the bigger mainframes. Finally, some machines support 8-bit bytes, some 7, and some 9. If the model you use in your program depends on any of these features, your program will be portable only to those machines with the same feature.

Even when a program is not directly portable, however, the use of appropriate models lets much of the program be identical in different environments, with the differences isolated in subroutines or compiled conditionally. For example, the Unix file system has many properties that are independent of a particular machine: the naming conventions, hierarchy, protection mechanism, and allocation and deallocation. Machine-dependent features, such as the sizes of sectors on the disk and the number of files that may be defined, are hidden in a small number of machine-dependent functions and data descriptions. This means that the system is portable in the sense that it can be moved in much less time than it requires to rewrite it from scratch. The key to moving the system is to write the machine-dependent information that supports the underlying model. If the C code written does not fit the basic model (for example, type mismatches between a function definition and its uses), the code may work on one machine but fail on others.

No language is perfect, or even close, and C is no exception. Some of the early design decisions are at best open to serious debate. One is the treatment of floating-point quantities; the current C definition requires all intermediate floating-point expressions to be evaluated in double precision. This can lead to significant inefficiencies for floating-point applications. Another problem is the large number of operators that have side effects; this becomes even more serious when you observe that C makes no promises about evaluation order in an expression or, in particular, the order in which arguments to a function are evaluated. Consequently, some programs can fail when run on different machines, and it can be very hard to check for this problem mechanically. As a

INNOVATORS IN Winchester SUBSYSTEMS!

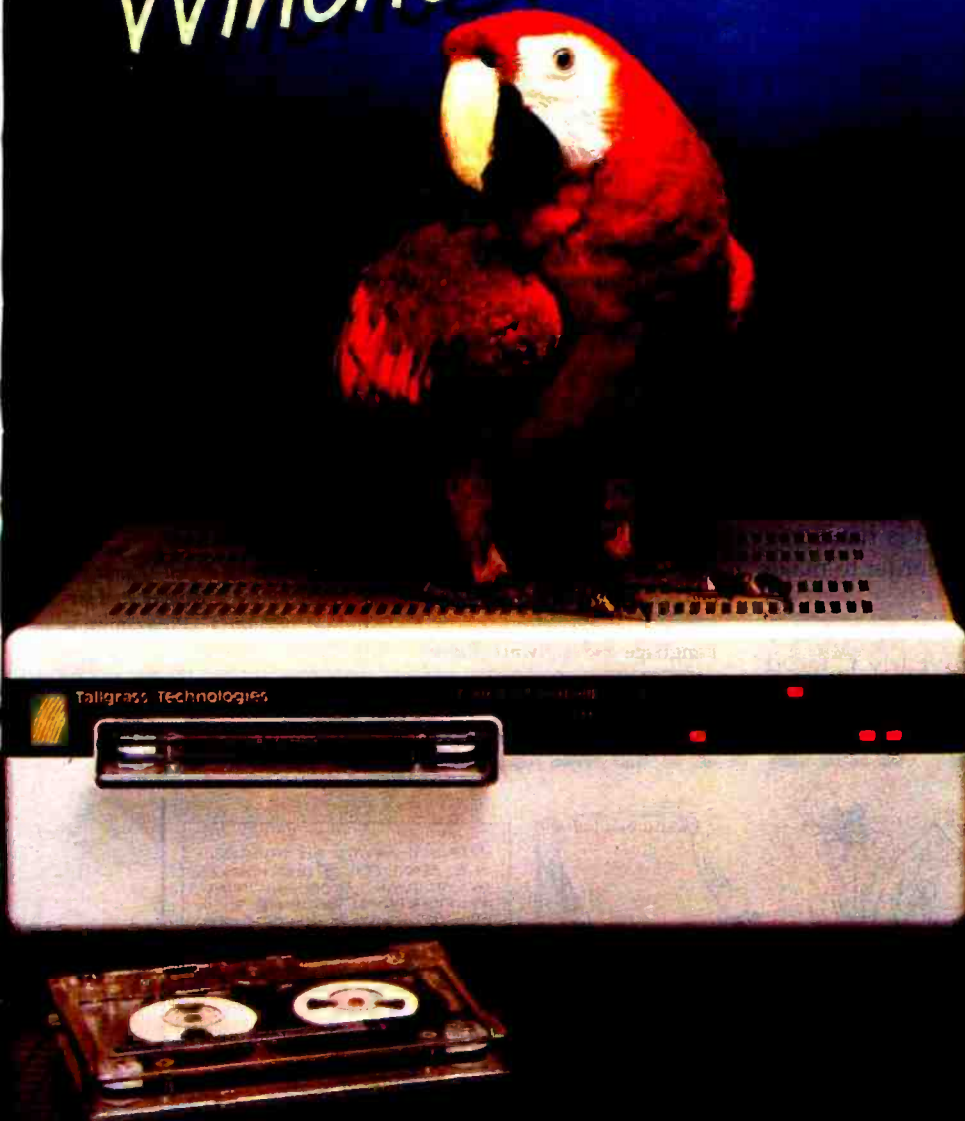

TALLGRASS AND YOUR IBM® PC

Tallgrass Technologies is the industry leader in Winchester HardFile™ and streaming tape subsystems for the IBM® PC and related computers. Fortune 500 corporations, banks, governmental agencies, and small businesses throughout the world depend on Tallgrass HardFile subsystems for their mass storage and backup requirements.

Tallgrass offers formatted capacities from 6.25 Mb to 70 Mb with integral streaming tape back-up. Our proprietary disk/tape controller with integral 10K track buffer optimizes read/write activity and, coupled with our DMA host interface, offers high performance previously unavailable with 5 1/4" disk systems.

WHAT ABOUT DATA INTEGRITY?

Tallgrass offers backup on ANSI standard 1/4" tape cartridges, instead of the usual floppies, video cassettes, or low-capacity removable Winchester devices. The Tallgrass 12.5 Mb formatted HardFile can back itself up on a \$39.95 data cartridge in less than 10 minutes!

TALLGRASS IS UNSURPASSED

We've done our homework in engineering and building a reliable HardFile subsystem with remarkable performance and convenient backup for the most stringent on-line mass storage and off-line archival requirements.

From \$2,995 U.S. including integral tape back-up. Available from COMPUTERLAND® and other participating computer dealers.

Exclusive Canadian Distributor
Micro-Ware™
440 Phillip St.
Waterloo, Ontario N2L 5R9
(519) 884-4690

Exclusive European Distributor
CPS Computer Group, Ltd.
Birmingham,
England B27 6BH
(021) 7073866



**Tallgrass
Technologies**
Corporation

11667 W. 90th, Overland Park, KS 66214, (913) 492-6002
Telex: 215406 TBYT UR

simple illustration, suppose that we have a function called `print` that prints the value of a variable `n` and the value returned by a function `f`. There is a natural tendency to believe that the statement

```
print(n, f());
```

will print the value of `n`, then the value returned by `f`. But if `n` happens to be a global variable that is changed by `f`, the results depend on the order in which the arguments of `print` are processed. This problem is certainly not limited to C, by the way—similar issues arise the same way in most languages.

The C Programmer

Another model implicit in a language environment is that of the programmer. Much of the C model relies on the programmer always being right, so the task of the language is to make it easy to say what is necessary. C encourages telling the truth about strange constructions (e.g., casts for pointer assignments) but does not prohibit them. The converse model, which is the basis of Pascal and Ada, is that the programmer is often wrong, so the language should make it hard to say anything incorrect. In Pascal (and presumably Ada) it is harder to say strange things and therefore perhaps harder to make mistakes.

By now it should be clear that C was intended as a language for professional programmers. Early C faced

problems familiar to users of today's microcomputers (for years, the C compiler had to run in 12K bytes of program plus data), and many traits of the early years are still with us. The cryptic error messages in most compilers were relatively unimportant for professionals but tough on casual users. Also, C is definitely packaged as a compiler, not a programming environment, so input must typically be created with a text editor, placed in a file, and handed to the compiler. On some systems, this is rather painful, and it also makes it harder for the novice to get started. Finally, the large amount of freedom provided in the language means that you can make truly spectacular errors, far exceeding the relatively trivial difficulties you encounter misusing, say, BASIC. One or two such goofs while learning the language can lead a beginner to burn the manual. Despite its problems, however, C continues to be used and developed, a good sign that there is a place for a portable low-level language with powerful model-building facilities. ■

Steve Johnson is head of computer systems research at Bell Laboratories (600 Mountain Ave., Murray Hill, NJ 07974) and designs languages for VLSI (very-large-scale integration) integrated-circuit design. He is the author of the Unix portable C Compiler and the YACC parser generator.

Brian Kernighan is head of computing structures research at Bell Laboratories and is interested in document preparation, programming languages, and programming methodology. He is the coauthor of The C Programming Language and Software Tools.

History of the Modem, Part 1

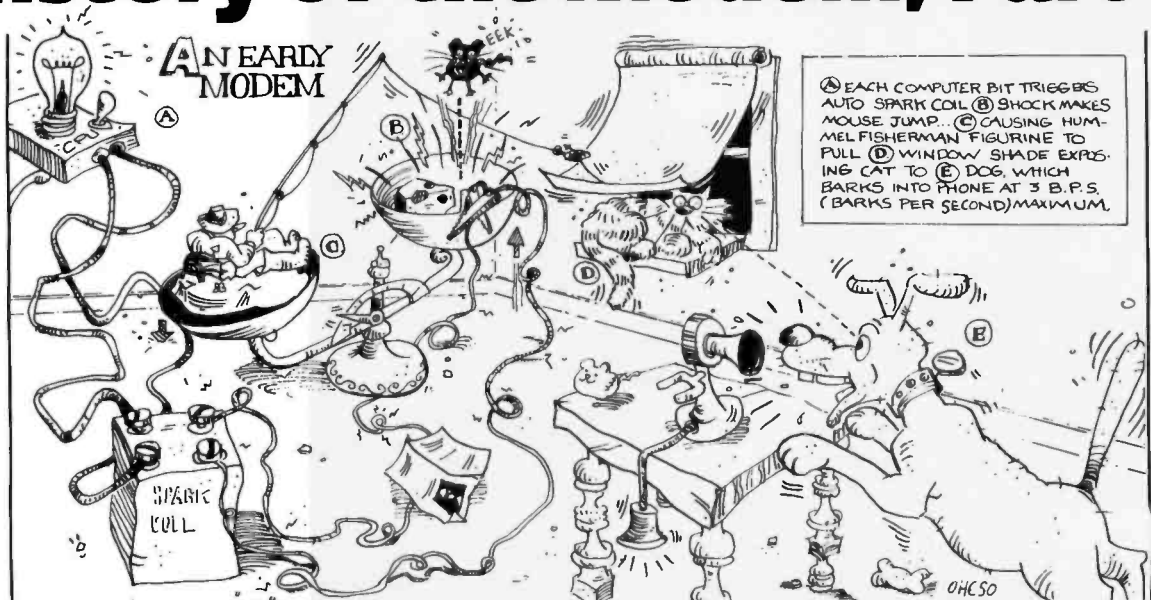

The Signalman™ Modem of Today

300 or 1200 BPS, Direct Connect. Comes complete with cables. Engineered specifically for individual computer models. Audible signals; Simplified Controls. Compact. Comes with Special Subscription Offer for THE SOURCE.

Manufactured by Anchor Automation,
World's Largest Modem Maker.

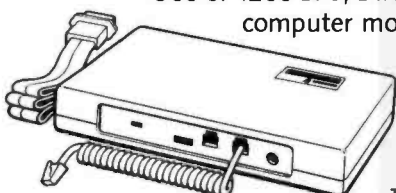

SIGNALMAN

from Anchor Automation
6913 Valjean Avenue,
Van Nuys, CA 91406

THE SOURCE is a Servicemark of Source Telecomputing Corporation.

APPLE IN IBM. THE LINK IS HERE.

From Quadram comes Quadlink™ The Apple-IBM link. The door to a whole new world of software for your Personal Computer.

Quadlink. Simply plug it inside your PC, press a few keys, and instantly your computer becomes an Apple-compatible system. Able to run

virtually any Apple software package available. Now you can choose from the largest soft-

ware library ever written. Business, educational, and entertainment packages. And never worry about "compatibility" again. Quadlink makes it possible. So enhance your PC system. Link up to a whole new

world of Apple software. With Quadlink by Quadram. (And remember, Quadlink works great with Quadram's other popular PC enhancement board, the six-function Quadboard.) Available now at authorized full-service Quadram dealers worldwide.

The 'link is finally here.



4355 International Blvd./Norcross, Ga. 30093
(404) 923-6666/TWX 810-766-4915 (QUADRAM NCRS)

Apple is a registered trademark of Apple Computer, Inc.
IBM is a registered trademark of International Business Machines Corporation.

Circle 331 on inquiry card.

Here's what makes this TeleVideo Personal Computer so attractive:

Easier on the eyes. The non-glare screen and sharp resolution makes it easier to read charts, graphs, characters and numbers.

More memory. 64K Bytes of memory is included as a standard feature. (Additional memory is also available).

More reliability. Vertical cooling tower keeps the computer cooler so it'll perform better and last longer.

More workspace. Video screen is 20% larger than the standard screen, so you don't have to strain to see your work.

Graphics. A wide variety of advanced business graphics can be displayed on TeleVideo's special screen.



More applications. Because the TeleVideo personal computer uses CP/M[®] software, no other computer has more software applications than TeleVideo.

Easier to read. Tilting screen adjusts up and down to natural line of sight.

More storage. The standard two 370 Kbyte floppy drives is enough to accommodate growth in the future.

Easier number manipulation. Standard calculator keyboard is more familiar, so you can work faster and make fewer errors.

Easier to Use. Detachable keyboard moves anywhere on your desk, or even onto your lap.

Less exhausting. Unique palmrest lets you rest your hands while you're working.



Compact. TeleVideo takes up very little space on the desk.

The TeleVideo Super Mouse.™ By moving the Super Mouse on the pad, you can control computer functions without the use of complicated keyboard codes (optional).

Here's what makes it irresistible:

\$2495⁰⁰

The TeleVideo TS 803 personal computer has everything other leading personal computers have, and then some.

In fact, some of TeleVideo's easy-to-use features can't be found on any computer, no matter how high its price.

Which makes our low \$2495 price doubly attractive.

So why resist?

Before you buy any personal computer, look into the family of

TeleVideo personal computers and personal computer networks. For more information, write TeleVideo Systems, Inc. 1170 Morse Ave., Sunnyvale, CA 94086, call toll-free **800-538-1780**, call one of our authorized distributors or dealers, or contact one of our international sales offices, listed below.

European Sales (Holland), (31) 075-28-7461
UK/Scandinavia Sales, (44) 0908-668-778

TeleVideo Systems are fully serviced nationwide by TRW.

 **TeleVideo Systems, Inc.**

A C Language Primer

Part 1: Constructs and Conventions in C

by James Joyce

Part 1 of this two-part article includes a brief overview of the C language and its history as well as examples of programs that demonstrate C's features. Because I have assumed that readers are familiar with a programming language, I have not defined such common programming concepts as variables, loops, functions, and arguments.

*The examples that follow will help you to explore C's features. Each example is a small program that explores a single aspect of the language, placing the focus on the feature instead of on the program or its possible applications. The only drawback to this approach is that it sometimes sacrifices utility for exposition. For further explanation, I direct you to the definitive reference for useful C examples, *The C Programming Language*, by Brian Kernighan and Dennis Ritchie.*

To reinforce what you learn, I recommend that you enter each program into a computer. After the program runs successfully, experiment with omitting or changing parts of it. Introducing deliberate errors will provide a controlled orientation to C's sometimes cryptic error messages and will be valuable experience for interpreting compiler diagnostics. As is the case with many programming languages, errors in C can have a cascading effect—when many errors are actually the result of one.

This article does not pretend to explain everything you will want to know about C. The idea is to get you started with key constructs and conventions in C that you will eventually encounter.

C was developed in Bell Laboratories at Murray Hill, New Jersey, in 1972. Created by Dennis Ritchie, it was based on the language B, Ken Thompson's adaptation of BCPL (basic combined programming language). Because the letters B and C are sequential in both the alphabet and in BCPL, some contend the successor to C will be D, and others say it will be P. As with ALGOL 68 and PL/I, many insist that C is *the* programming language and that it will last forever.

Unix and C have been intimately associated from C's beginning. Unix was originally written in assembly language, and transporting it to other hardware was a growing problem as new utilities and functions were added. With C available, Thompson and Ritchie rewrote Unix, leaving only a few very low-level routines in assembly language. Transporting Unix to another computer is mainly a matter of writing a C compiler for the target computer. Most of the several hundred C programs that make up Unix compile without a change in code on the

new hardware, a feature that has helped make Unix and C so popular today.

Because C appears to be so portable, it is tempting to talk about "standard" C. Such a standard exists implicitly in the Unix program `lint`, which parses C programs looking for machine-dependent code. Though quite intelligent for a program, `lint` can be fooled.

A partner program in C standardization is `cb`, the C beautifier program, which reformats C code according to the program's structure. Thus a programming team can run its programs through `cb` to gain an overall uniformity of code format. Uniformity reduces the effort needed to get to know another team member's code, in turn making maintenance easier. The C beautifier can also be used as a debugging aid because comparing the reformatted version to the original may reveal misplaced or missing code.

Good style in C is important because C programs can be very hard to read. For example, compound statements



The Professional's Editor for Program Development Word Processing Source Code Translations

Widely acclaimed as an editor, VEDIT has evolved to be much more. Only VEDIT offers the combination of a versatile full screen editor integrated with a powerful command language. For the first time you'll be able to perform complex, yet useful, text manipulations that are virtually impossible with other editors or word processors. Plus, its customizability and hardware support ensure that VEDIT will be perfectly matched to your individual needs and to any microcomputer you are ever likely to own.

With two modes of operation, VEDIT never compromises its speed or ease of use for its power and sophistication. As one reviewer (Bradford Thompson, BYTE) wrote: 'If this review gives you an appetite for simplicity while editing, then VEDIT is well worth considering.' Its command language, based on TECO, is virtually a text oriented programming language, allowing command macros to be created, loaded and saved on disk. Yet its simplicity allows even a novice to perform tasks beyond the capabilities of any word processor.

VEDIT cuts programming time in half - with multiple file handling, macro capability and special features for Pascal, PL/1, 'C', Cobol, Assembler and other languages. And it can help with source code translations (example ZILOG to/from INTEL translator macros are included). A complete line of translators will be available by the year's end.

Word processing is a snap with word wrap, paragraph and print functions. Command macros free you from tedious search/replace operations. Hundreds of search/replace on dozens of files can be performed by VEDIT without waiting or intervening.

VEDIT easily configures to your favorite keyboard layout. Use any function or cursor keys you wish. It optimally supports nearly every 8080, Z80 and 8086 computer.

Go ahead and expect a lot from VEDIT. Its performance and our support will satisfy your most exacting needs.

To order, please specify your 8080, Z80 or 8086 microcomputer, operating system and disk format.

COMPARE VEDIT'S FEATURES

- True Full Screen Editing
- Horizontal scrolling
- Edit files one disk in length
- Automatic Disk Buffering
- Compact (only 16K) and Fast
- Display of line and column #
- Set/Goto text markers
- 'Undo' key to restore line
- Automatic Indent/Undent
- Adjustable Tab positions
- Repeat function key
- Text Move and Copy
- 10 Scratchpad Buffers
- Load/Save buffers on disk
- Powerful command macros
- Directory display
- Edit additional (small) files simultaneously
- Insert another disk file
- Unlimited file handling
- Recovery from 'Full Disk'
- Change disks while editing
- Word wrap, format paragraph
- Simple Printing
- 150 page indexed manual
- Startup command file
- Menu driven installation
- Program CRT function keys
- Support newest CRT terminals
- Support smart CRT functions
- Flexible Memory Mapped support
- Customizable keyboard layout

IBM PC, Displaywriter[®] Zenith Z100 and Z89[®] NEC APC[®] DEC Rainbow and VT180[®] Televideo 802
TRS-80 I, II and 16[®] Xerox 820[®] Apple II Softcard[®] SuperBrain[®] NorthStar
MP/M[®] CP/M-86[®] MP/M-86[®] Concurrent CP/M-86[®] Cromix[®] Turbo DOS[®] MSDOS[®] PCDOS

VEDIT - Disk and Manual
8080, Z80 or IBM PC \$150
CP/M-86 or MSDOS \$195
Manual only \$18



CP/M and MP/M are registered trademarks of Digital Research Inc. Apple II is a registered trademark of Apple Computer, Inc. MS-DOS and Softcard are trademarks of Microsoft. TRS-80 is a trademark of Tandy Corporation. IBM is a trademark of International Business Machines.

CompuView
PRODUCTS, INC.

Circle 107 on inquiry card.

1955 Pauline Blvd., Suite 200[®] Ann Arbor, Michigan 48103[®] (313) 996-1299

that in Pascal are grouped by the keywords `begin` and `end` are grouped by the easy-to-miss `{` (leftbrace) and `}` (rightbrace) in C. Add to this the fact that C is free format (without line numbers), and the ill-considered placement of a brace can easily introduce a bug.

Another feature of C that can cause difficulty is that expression values can be changed in the middle of a logical test. The C instruction

```
if ( (byte = getchar()) == 'X' ) count++;
```

causes the function `getchar()` to read a character, which is assigned to the variable `byte` and tested by `==` for equality to `X`, all within the conditional test of an `if` statement. This feature makes for compact code and can confuse the unwary.

C Program Structure

This is the smallest possible C program:

```
/*-- small.c The smallest C program --*/  
  
main() /* a comment */  
{  
}
```

Comments in C are, as in all languages, optional but highly desirable. C comments are enclosed PL/I-style within the comment delimiters `/*` and `*/`. A routine called `main` is required for each and every C program. The pair of braces in the subsequent lines are also required, and any executable code for `main` must appear inside them. Although the example is simple—there is no executable code, so the program does nothing—I encourage you to enter and run it.

To compile this example under Unix the command is

```
$cc small.c  
$
```

C programs under Unix must be in a file whose name ends in `.c`, or else they will not compile properly. If the compilation is successful, there will be no messages from the compiler: the compile will end, and control will return to the shell (Unix's command interpreter), which uses the `$` (dollar sign) to prompt for another command.

The ready-to-run program, which is named `a.out`, will be in your current directory. If the C compiler had detected errors, the errors alone would be printed, along with an indication of the line number at which the error had become obvious. You may need to examine other lines in the vicinity of the reported error to find the real culprit.

This "silent treatment" can be disconcerting if you're new to C. But as your confidence in writing C programs builds, you will grow to prefer its brevity. To learn what messages C gives when `main`, the parentheses, or the braces are missing, try running the program without them. This is good practice in reading diagnostics.

The `cc` command causes the compiled code to become an executable file named `a.out`. To run the program, simply type `a.out`. When the program has finished running, control is returned to the shell, which again prompts with a `$`. You see no output because `small.c` does nothing.

The entire program could have been written as one line, as shown here:

```
/*-- small2.c The smallest C program, on one line --*/  
  
main() { }
```

The format of the first version is the style Kernighan and Ritchie recommend.

Functional Structure of C Programs

C programs are made up of functions, minimally the function `main`. Our first program can be thought of as a do-nothing function: there are no arguments given to the function, and no processing is done. Good programming style in C encourages you to structure a big program as a number of small functions. The good C programmer will break large programs into smaller ones and write a function for each. If each function can stand alone, the programmer eventually develops a "toolbox" of useful programs that can be combined in different ways to solve problems. This is a very important and powerful concept.

In the example that follows, `main` calls a function, `doit`, that doesn't do anything. This is a bare-bones example of a `main` program calling another function.

```
/*-- smallsub.c Smallest C program with a subprogram --*/  
  
main()  
{  
    doit();  
}  
  
/*-- doit doesn't do anything --*/  
  
doit()  
{  
}
```

The call to `doit` is given in `main` within the braces because functions are executable—even if they don't do anything but return control to the `main` function, as they do here.

A function is invoked by stating its name; arguments to be passed to the function are placed within parentheses after the name. The semicolon after the call to `doit` is C's statement terminator (as found in PL/I) rather than simply a statement separator (as in Pascal or other ALGOL-like languages). In other words, a semicolon must appear at the end of every legal statement in C.

After the code for `main` comes the definition of `doit`. The definition is like that of `main`, further emphasizing that

C programs are made up of one or more functions. Function definitions may not be nested in C. That is, the definition of `doit` cannot be inside `main`. Once you have this program running successfully, try defining `doit` inside `main`'s braces to view the message C gives.

Functions can be defined in any order, although `main` is typically the first function in a program. Try moving the definition of `doit` in front of `main` and compile the result to verify that functions can be defined in any order.

Printing a Message

The library function `printf` prints output on the standard output device, your terminal, unless redirected to another destination:

```
/*-- hello.c Greet the world, introduce output in C --*/
```

```
main()
{
    printf("Hello, world! \n");
}
```

The message printed by this example is, of course,

"Hello, world!"

It is coded as a character string within parentheses in the `printf` statement. The `printf` statement is simply a function call. Notice that the string between the " (double

quotes) ends with the two characters `\n` (backslash-n). This combination is C notation for a *newline* character, which on a computer's video terminal (or printer) will position the cursor (or print head) at the beginning of the next line.

In C, as almost everywhere in Unix, the `\` (backslash) is the *escape character*, signaling that the character that follows is to be treated differently than it would be without the `\`. Other common combinations include `\b` for backspace, `\f` for form feed, `\r` for carriage return (to the beginning of the current line), `\t` for tab, `\"` for double quotes (rather than simply `"`, which would signal the end of the character string), and `\\` to indicate the backslash.

All arguments of a function must be on the same line in C. Because `printf` is a function, the entire string within `printf` must be on the same line. If you have a particularly long character string to print, it can be broken up into several segments, each printed using a `printf`:

```
/*-- stream.c Print "Hello, world" as stream output --*/
```

```
main()
{
    printf("\t");
    printf("Hello");
    printf(", ");
    printf(" ");
    printf("world");
    printf("!");
    printf("\n");
}
```

Because only the last line contains a notation for a newline character, the `printf` statements print one after another on the same line. The output is a stream of characters, one after the other up to and including the newline.

Variables, Assignment, and Output

Variables in C may be any length, though only the first 8 characters matter (external variables and function names may be restricted to fewer characters, depending upon the machine being used). Variables must be declared explicitly:

```
/*-- var.c Introduce printf to print a variable --*/
```

```
main()
{
    int age;

    age = 40;
    printf("This year Sam is %d years old. \n", age);
}
```

Although `int` is short for integer, you cannot use the term "integer" to declare a variable. The `=` (equal sign) in the statement following the declaration is used for the assignment of values to variables.

PROGRAMMERS FLIGHT SIMULATOR
Apple II Plus DOS 3.3 48K



This total IFR System disk features gobs of menu selectable flight programs each with breath taking realistic picture graphics, moving scenery, airport approaches, holding patterns and much much more.

\$50.00 At your Computer Store or direct from
Visa Mastercard

Programmers Software
2110 N. 2nd Street
Cabot, Arkansas 72023
(501) 843-2988



Apple II compatible
of RAM

Upper & lowercase



Typewriter-style
keyboard



12-key numeric pad



VisiCalc keys



50-watt power supply



Built-in fan



1982



ACEWriter II

Sophisticated word processing that's easy to learn

ACECalc

VisiCalc*-compatible spreadsheet analysis program with 80 columns of variable width

ACE Display card

Opens video display to a full 80 columns by 24 lines

ACE 80 CPU card

Allows you to run CP/M and Apple® II programs

ACE Dual Interface card

Allows you to connect to local and remote printers, terminals, computers and other accessories



Apple II compatible
of RAM

Upper & lowercase



Typewriter-style
keyboard



12-key numeric pad



VisiCalc keys



50-watt power supply



Built-in fan



1983

Good. Better.

And you thought Franklin was good before.

Well, look at Franklin now. You'll find our ACE product line has grown . . . and grown. To include sophisticated word processing. Sensational spreadsheet analysis. And an array of peripheral boards. So you can expand the capabilities of your ACE 1000 as your business needs increase. Our product line's not the only thing that's grown. Franklin now has more than 1,000 authorized dealers throughout the country. So, if you thought we were good before, come see us now.

Apple is a registered trademark of Apple Computer Inc.
VisiCalc is a registered trademark of Visi Corp.

2128 Route 38; Cherry Hill, NJ 08002 Telephone: 609-482-5900; Telex: 837-385



Circle 175 on Inquiry card.

The intensity of Scrabble,[®]
the excitement of Boggle,[®]
the imagination of word search games...

WORD CHALLENGE™

The Ultimate Word Game.



Ready for some mental gymnastics? Take on Word Challenge. You'll race the clock with LEX, an opponent of uncannily human intel-

ligence, to find hidden words in a square of random letters. (The sample square has 142 words.) Longer words score better points, so while you might enter "cap," "ape" and "tea," LEX is picking out "aster," "repast" and "sacred," all part of his remarkable 90,000-word vocabulary. But don't give up. You can select from 26 different skill levels, choose the square size (3 x 3, 4 x 4 or 5 x 5), time limit and a variety of scoring methods.

Word Challenge. Only \$39.95 at your computer dealer. For Mastercard and Visa orders, call toll-free, 1-800-323-0023. In Florida, call collect, 305/566-3511. Or complete the coupon and send check or M.O. to: Word Challenge, Proximity Software, 3511 N.E. 22nd Avenue, Fort Lauderdale, Florida, 33308.

PROXIMITY™

Please send _____ Word Challenge Disk(s) for which I've enclosed \$39.95 each (plus \$2.00 shipping and handling). Florida residents please add 5% sales tax.

Check appropriate box.

- Apple II, II Plus or II Plus E (min 48k) w/disk
- IBM Personal Computer (min 64k) w/disk
- Osborne I (min 64k) w/disk

Name _____

Address _____

City _____ State _____ Zip _____

Apple, IBM and Osborne are registered trademarks of Apple Computer, Inc., International Business Machines Corp. and Osborne Computer Corp., respectively. Boggle and Scrabble are registered trademarks of Parker Brothers Division of CPG Products Corporation and Selchow and Rlichter, respectively. BY883

Notice that the printf statement is slightly different and has two parts to it; a comma separates the character string, enclosed in double quotes, from the variable name age. The character string also has something new in it, %d, telling printf that a decimal integer is to replace the %d during output. The %d corresponds to the variable age; the printf function will allocate enough space in the character string for the width of the value that replaces %d. The value of age will be inserted into the character string to produce the following message:

This year Sam is 40 years old.

The character string is, then, an output control string for formatted output, providing guidance to the printf function.

Sometimes C programmers forget to declare a variable. You can discover C's message about that by deleting the int declaration, then recompiling the program. You can get the program to work again by deleting the assignment statement and substituting the constant 40 for age in the printf statement.

There are, of course, other variable types in addition to int, and you will meet them in later examples. C has several powerful control structures you will want to learn first, with other variable types introduced in appropriate circumstances.

Looping with while and Incrementing

We can use essentially the same program to introduce an aspect of looping while incrementing:

/-- while.c The while construct --*/*

```
main()
{
    int count;

    count = 1;
    while (count <= 4) {
        printf("%d \n", count * 10);
        count = count + 1;
    }
}
```

The statement with the comment */* A */* sets the condition, given in parentheses, that count be less than or equal to 4 for execution of the loop to continue. The loop includes the two statements within braces, beginning with the end of line A and ending with line D. The braces enclose a *compound statement* in C (i.e., one or more statements treated as if they were a single statement). That the brace in A is on the same line as the while is the preferred style in C.

The two statements in the loop print the desired number and increment the variable count. What's new here is that, in line B, we demonstrate that the variable in printf can be an expression—in this instance, count * 10 (the asterisk means multiplication). The expression in

"I built this 16-bit computer and saved money. Learned a lot, too."

Save now by building the Heathkit H-100 yourself. Save later because your computer investment won't become obsolete for many years to come.

Save by building it yourself. You can save hundreds of dollars over assembled prices when you choose the new H-100 16-Bit/8-Bit Computer Kit – money you can use to buy the peripherals and software of your choice.

H-100 SERIES COMPUTER SPECIFICATIONS:

USER MEMORY:

128K-768K bytes *

MICROPROCESSORS:

16-bit: 8088

8-bit: 8085

DISK STORAGE:

Built-in standard

5.25" disk drive,

320K bytes/disk

KEYBOARD:

Typewriter-style,

95 keys, 13

function keys,

18-key numeric pad

GRAPHICS:

Always in graphics mode.

640h/225v resolution;

up to eight colors

are available**

COMMUNICATIONS:

Two RS-232C Serial

Interface Ports and

one parallel port

DIAGNOSTICS:

Memory self-test

on power-up

AVAILABLE SOFTWARE:

Z-DOS (MS-DOS)

CP/M-85 +

Z-BASIC Language

Microsoft BASIC

Multiplan

SuperCalc

WordStar

MailMerge

Data Base

Manager

Most

standard

8-bit CP/M

Software

*128K bytes standard.

**Optional.

The H-100 is easy to build – the step-by-step Heathkit manual shows you how. And every step of the way, you have our pledge – "We won't let you fail." Help is as close as your phone, or the nearest Heathkit Electronic Center.†

And what better way to learn state-of-the-art computing techniques than to build the world's only 16-bit/8-bit computer kit? To run today's higher-speed, higher-performance 16-bit software, you need an H-100. It makes a big difference by processing more data faster.

Dual microprocessors for power and compatibility. The H-100 handles both high-performance 16-bit software and most current Heath/Zenith 8-bit software.

Want room to grow? The H-100's standard 128K byte Random Access Memory complement can be expanded to 768K bytes – compared to a 64K standard for many desktop computers.

And the industry-standard S-100 card slots support memory expansion and additional peripheral devices, increasing future upgradability of the H-100.

High-capacity disk storage, too. The H-100's 5.25" floppy disk drive can store 320K bytes on a single disk. The computer also supports an optional second 5.25" and external 8" floppy disk drives. And an optional internal Winchester disk drive will be available soon.

For more information, circle the reader service number below. Better yet, visit your Heathkit Electronic Center for a demonstration!

The H-100 gives me the most for my computer dollar!



Heathkit®

Heath
Company

Heathkit Electronic Centers are units of Veritechnology Electronics Corporation.
Heath Company and Veritechnology Electronics Corporation are subsidiaries of Zenith Radio Corporation.
+ CP/M is a registered trademark of Digital Equipment Corporation.

Circle 193 on Inquiry card.

line C, `count = count + 1`, is not used much in C because there is a much shorter notation that we will examine in the next example.

Line D contains the brace that ends the while loop. It is lined up under the `w` of `while` as a matter of style. As an experiment, you can remove the statement that sets `count` to 1 to learn how C treats an undefined variable. (Some undefined variables are given an initial value by the C compiler so that they don't have garbage in them. More on this can be found in section 1.10 of Kernighan and Ritchie's book.) In this instance, the value of `count` is arbitrary, and you may have a runaway loop (on most Unix systems, this can be stopped by pressing the Break key or the Rubout key).

In the example that follows, the term `count++`; replaces `count = count + 1`;

```
/*--- while2.c The increment-by-one operator ---*/
```

```
main()
{
    int count;

    count = 1;
    while (count <= 4) {
        printf("%d \n", count * 10);
        count++;
    }
}
```

This illustrates a powerful legal C construct, the increment operator, which is unusual in high-level languages. The `++` assures the C compiler that you're telling it you want to increment `count` and that you have not mistyped the statement. The `++` is an operator that means "increment by one," and under some circumstances it is faster than using `count = count + 1`; (it is certainly easier to type). Although it is not required, putting the increment-by-one operator next to the variable it affects, without intervening spaces, helps those who must read the code later.

Here's a further example of how the increment operator may be used in C:

```
/*--- while3.c Increment-by-one in expressions ---*/
```

```
main()
{
    int count;

    count = 1;
    while (count <= 4) {
        printf("%d \n", count++ * 10);      /* E */
    }
}
```

In line E, the variable `count` has been rewritten `count++` so that the increment-by-one operation is done within the `printf` statement. Some feel this and similar practices

make C hard to read, and for the uninitialized that can be true. You should be aware of this use of `++`, if only so that you can read other C programs. With practice you may even grow to *feel* this use is quite natural.

It is instructive to change `count++` to `++count` in the above example and then run it. The `++` operator may be used as both a suffix and a prefix, to affect the contents of a variable before the expression is evaluated or after. When `++` is used as a suffix, `count` is initially 1, its value is printed, `count` is incremented, and the loop begins again. When `++` is a prefix, `count` is initially 1, but `count` is incremented before its value is printed.

There is a corresponding "decrement by one" operator, `--`, which follows the same rules. If you experiment with the increment and decrement operators, keep in mind that you may want to change `<=` (less than or equal) to `>=` (greater than or equal) to prevent the program from going into an infinite loop. Try changing `count` to `count++` in the `while` instruction, leaving simply `count` in the `printf` statement.

Looping with for

C's `for` statement has three parts within its parentheses:

```
/*--- for.c The for construct ---*/
```

```
main()
{
    int count;

    for (count = 1; count <= 4; count++)      /* A */
        printf("%d \n", count);              /* B */
}
```

The first part initializes the `for`. The second indicates the condition allowing the loop to continue. The last part indicates what is to be done at the "bottom" of the loop (in this example, `count` will be incremented *after* `printf` prints).

The body of the `for` loop is given in line B. You might want to add a `printf` after the `for` loop to see that the loop-controlling variable, `count`, retains its value outside the loop. This contrasts with `for` loops in Pascal and `do` loops in FORTRAN, in which the loop-controlling variable is technically "undefined" upon exit from the loop.

The `printf` can also be included in the third part of the `for` loop:

```
/*--- for2.c The for loop with null statement body ---*/
```

```
main()
{
    int count;

    for (count = 1; count <= 4; printf("%d \n", count++))
        ;                                     /* C */
}
```

IT'S EASY TO DO BUSINESS WITH MICROHOUSE

FULL TECHNICAL SUPPORT, NEW LOWER PRICES—TOLL FREE NUMBER.
WE WILL ACCEPT MASTERCARD, VISA, PURCHASE ORDERS, C.O.D.

MEMORY SHIFT . . . \$95

Microhouse™

P.O. BOX 499
BETHLEHEM, PA 18016
Pennsylvania call:
215-868-8219

WORD PROCESSING

MICROPRO

WORDSTAR \$279
MAILMERGE 149
SPELLSTAR 149
FINAL WORD 199
WORDSTAR/MAILMERGE/
SPELLSTAR/STAR INDEX 395
WORDSTAR I MAILMERGE 349

FORCE II

MATHSTAR \$89

SORCIM

SUPERWRITER \$179
SPELLGUARD 129

IBM HARDWARE

QUADRAM

QUADBOARD II 64K \$295
QUADBOARD II 256K 475
SERIAL ADAPTER 94
PARALLEL PRINTER INT 99
64K MEMORY UPGRADE 129

APPLE HARDWARE

MICROSOFT

MICROSOFT PREMIUM PACK . . . \$489
Z80 CARD 249
MICROSOFT Z80 CARD/VIDEX
VIDEOTERM 479
MICROSOFT 16 RAM 69

MEDIA MAXELL

MAXELL MD-1 \$31
MAXELL MD-2 44
MAXELL FD-1 40
MAXELL FD-2 49

MONITORS

AMDEK

COLOR I \$ 349
COLOR II 559
COLOR III 399
VIDEO 300 159
VIDEO 300 AMBLER 169
VIDEO 310 169
VIDEO 310 AMBLER 179
COLOR IV 1099

MODEMS

US ROBOTIC—2 YEAR WARRANTY
300/1200, AUTO DIAL CALL!
HAYES CALL!

JUST A FEW OF
THE MANY SAVINGS
THAT WE OFFER YOU



TOLL FREE
800-523-9511

CALL FOR
WEEKLY
SPECIALS

DATABASE/ GRAPHICS

LOTUS

1-2-3 \$389

MICROPRO

INFOSTAR \$279
DATASTAR 165
SUPERSORT 149

ASHTON TATE

dBASE II/ZIP \$439
dBASE III/ZIP
QUICKCODE/DUTIL 699

FOX & GELLER

QUICKCODE \$219
DUTIL 68
D GRAPH 189

INNOVATIVE

TIM III \$275
FAST GRAPHS 189

NORTH AMERICAN

THE ANSWER \$169

FINANCIAL/ BUSINESS

SORCIM

SUPERCALC \$145
SUPERCALC II 179

VISICORP

VISICALC \$179
VISICALC APPLE IIE 179
VISICALC BUSINESS
FORECASTING 89
VISICALC ADVANCED CALL!
VISISCHEDULE 228
VISITREND/PLOT 228
DESKTOP PLAN-APPLE 179
DESKTOP PLAN IBM 228

ASHTON TATE

BOTTOM LINE STRATEGIST . . . \$319

CONTINENTAL

HOME ACCOUNTANT APPLE . . . \$ 59
HOME ACCOUNTANT PLUS IBM 99

PRINTERS

C. ITOH

PROWRITER (P) \$399
PROWRITER (S) 629
F10 (P) 1299
F10 (S) 1399
F10 TRACTOR OPTION 229

QUADRAM

MICROFAZER 16K P-P \$159
MICROFAZER 32K P-P 189
MICROFAZER 64K P-P 239
MICROFAZER 8K P-P 139
MICROFAZER 128K P-P 349
MICROFAZER 256K P-P 699

SMITH CORONA

TP-1 \$529
TRACTOR FOR TP-1 139

INTERACTIVE STRUCTURES

PKASSO \$155
PKASSO PRISM COLOR 175

ORANGE MICRO

GRAPPLER PLUS \$129

PRICES SUBJECT TO CHANGE WITHOUT NOTICE

Circle 269 on Inquiry card.

The lone semicolon in line C is still required by the syntax of the for loop, and it ends the null (or empty) statement that makes up the body of the loop. There is nothing in the loop; all action takes place in the parentheses after the keyword for. This practice, which occurs often in C, can result in fast code. The danger in this practice is that someone reading the code may later miss the null statement and mistakenly think the next construct is included in the for loop. To help avoid such misreading, the semicolon in line C is lined up under the f in for.

getchar and putchar

Now that you know several basic control structures, you're ready to be introduced to the library functions `getchar` and `putchar`. As functions, they are not part of C proper but are basic extensions necessary for writing most programs. The function `getchar` receives one character from *standard input* (the terminal's keyboard), and `putchar` sends one character to *standard output* (the terminal's video display).

The following simple program using `getchar` and `putchar` will copy one character at a time from input to output until it finds an end-of-file indicator:

```
/*--- copy.c Copy input to output ---*/

main()
{
    int byte;                /* A */

    while ( (byte = getchar()) != -1) /* B */
        putchar(byte);      /* C */
}
```

The end-of-file indicator from a terminal is a Control-D with Unix, which `getchar` signals by returning the integer `-1`; thus, to get out of this program, you need only type a Control-D at the keyboard. CP/M uses Control-Z for an end-of-file marker.

Line A declares `byte` as an integer, which at first seems strange because, as we said, the program copies characters; but the `getchar` function returns other values besides characters (among them the integer `-1`, which doesn't fall within the range of the `char` type). There is at least one version of C in which `byte` can be declared `char` and the end-of-file test in B will still work. Try changing `int` in A to `char` and rerun the program to see how your version of C behaves. If you run the `char` version of this program through `lint`, it will indicate that the "comparison" in line B is "nonportable."

So long as the condition in line B is true, the `while` loop will continue. It is a complex-looking expression, but you can break it into its parts readily if you work from the inside parentheses out: `getchar` is called and the value it returns is assigned to `byte`; the value of `byte` is then tested

against `-1`, and so long as they are not equal (the `!=` means inequality), line C is executed and the loop continues. The call to `putchar` has `byte` as its argument, with the result that the contents of `byte` are sent to the standard output.

The C compiler employs a *preprocessor* that can be quite useful in making programs readable:

```
/*--- copy2.c Use preprocessor variable for EOF ---*/

#define EOF -1                /* D */

main()
{
    int byte;

    while ( (byte = getchar()) != EOF) /* E */
        putchar(byte);
}
```

The `#` in line D is an indication that `define` is an instruction to the preprocessor. (Several other preprocessor instructions are given by Kernighan and Ritchie.) The action of the preprocessor can be likened to the expansion of macroinstructions in an assembler—it is not a separate program from the C compiler. Before the lines of the program are compiled, the `#define` instructs the preprocessor to replace every occurrence of `EOF` with the constant `-1`.

With the substitution made, line E in this program will mean the same thing to the C compiler as line B does in the previous example, and using the preprocessor makes the line more readable. This enables us to give symbolic names to special numbers (such as `-1`, when it signals end-of-file) or array boundaries in declarations or loops (as we shall see next month). The preprocessor will then replace the symbols in the program with the proper values before compilation. This approach improves both readability and maintenance.

We now know of two functions used for output: `printf` and `putchar`. Here is a quick illustration of how `printf` can be used in place of `putchar` in the previous example:

```
/*--- copy3.c Show printf equivalent of putchar ---*/

#define EOF -1

main()
{
    int byte;

    while ( (byte = getchar()) != EOF)
        printf("%c", byte); /* F */
}
```

The format specification `%c` tells `printf` that a single character of data is to be printed. Changing `%c` to `%d` will not produce a character, but rather a numeric (integer) interpretation of the value in `byte`. Normally we want to distinguish between character data and its possible in-

Never before could you manage so much data for so few dollars...

Base1™ gives you

No-Limit Flexibility

- ✧ Unlimited number of records
- ✧ Unlimited record size
- ✧ Unlimited number of fields
- ✧ Unlimited field size
- ✧ No requirement to define formats or data before entry
- ✧ Fast data access through special indexing
- ✧ Data structure accessible in BASIC
- ✧ Quick and easy field reorganization
- ✧ Space saving compression utility
- ✧ Full variable length processing
- ✧ Virtual information facility
- ✧ Index on any list of fields

Base1™ is a database for

- ✧ CP/M systems (8" SSSD 3370 format)
- ✧ IBM Personal Computer (PC DDS)
- ✧ Apple II, IIe and III (Apple DOS)
- ✧ TRS-80 (TRS-DOS)
- ✧ Osborne (CP/M)

Base1™ requires

- ✧ 32K of memory
(special buffering for larger memory systems)

Base1™

a software product from

XPER SYSTEMS
Software to rely on

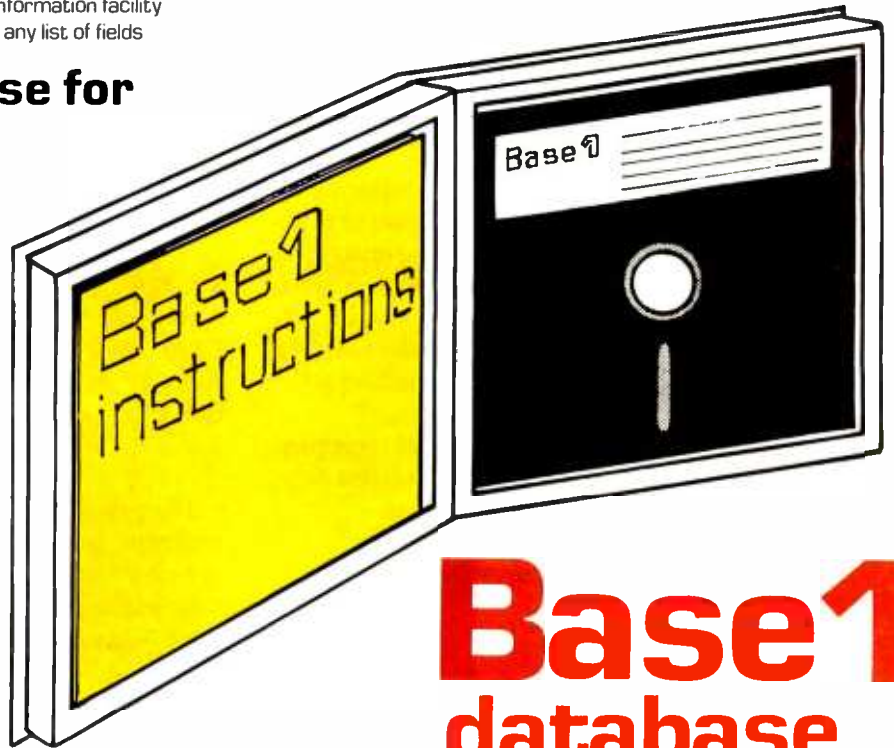

Base1™ database

\$19.95!

Visa/MasterCard

Call Now

(800)USA-3333

(Pennsylvania Residents) 800-292-9660 (PA residents add sales tax)

FREE media, shipping and handling on first 1,000 orders. (normally \$6.95 or \$9.95 for 8" media)

IBM is a registered trademark of International Business Machines, Apple is a registered trademark of Apple Computer, Inc., TRS-80 is a registered trademark of Tandy Corporation, Osborne is a trademark of Osborne Computer Corp., CP/M is a registered trademark of Digital Research, Inc.

terrelationship of char and int brings us too close to matters that are machine dependent.

if and else

C's if statement looks like if statements in many programming languages.

```
/*--- if.c Illustrate the if and else statements ---*/
main()
{
    int answer;

    printf("\tDo you like C so far? \n");          /* A */
    printf("\tType y for yes, or n for no: ");

    answer = getchar();
    if (answer == 'y')
        printf("\tGlad to hear it! \n");
    else
        printf("\tHope it changes. \n");
}
```

This example asks a question and prints a response depending upon the answer. Those used to Pascal or other ALGOL-like languages should note that a semicolon is required after the printf, just before the else, as a statement terminator. In this example, we also employ the logical operator == (is equal to). Note that the two printf statements that give the greeting are separated from the get-the-work-done portion of the program.

The logic of an if statement can become quite complex. Though we will avoid getting too deeply involved here, C allows the nesting of if and else constructs:

```
/*--- if2.c Illustrate nested if and else statements ---*/
main()
{
    int answer;

    greet();

    answer = getchar();
    if (answer == 'y')
        printf("\tGlad to hear it!\n");
    else if (answer == 'n')                /* B */
        printf("\tSorry to hear that. Hope it changes. \n");
    else
        printf ("I don't understand %c.", answer);
}

greet() /*--- greet the user ---*/
{
    printf("\tDo you like C so far? \n");
    printf("\tType y for yes, or n for no:");
}
```

Line B shows that if the answer character is not y, the program is to check whether the character was an n. If that test fails as well, an error message is printed.

In C, an else refers to the most recent if that does not already have a closer else. Kernighan and Ritchie think all if and else statements should be lined up under each other, no matter what the depth of nesting, to prevent the code from drifting off the right-hand side of the screen or page. But the risk of associating the wrong else with an if seems too great without indenting, and the consequences too hard to detect, so I propose using the approach illustrated. (This is an instance in which the cb program perhaps should indicate its perception of the program structure; instead, it dutifully formats according to Kernighan and Ritchie's suggestion.)

Good programming style encourages you to structure programs as a number of small functions. While this is not a big program and could quite easily be written as a single function, the idea of structuring code is still a good one. There is no need to clutter main with the printf statements that greet the user. They belong in their own function. If someone wants to modify the greeting later, it can be done more easily with the printf statements suitably identified.

It may be helpful to see what this example would look like as it was compiled and run under Unix:

```
$ cc if2.c
$ a.out
Do you like C so far?
Type y for yes, or n for no: y
Glad to hear it!
$
```

The program typed the question through a call to the function greet and then waited for a reply. The user typed a y and pressed the Return key. The first if was satisfied and the appropriate message printed. Because the if was satisfied, there is no need to consider the else statement, and the program ends.

Had the response been n, the first if would have failed and the else statement would have taken effect. The if test for n would be satisfied and the message of sympathy would be printed. Again, satisfying the if condition means the subsequent else is skipped and the program ends. If the response had been anything other than y or n (even uppercase Y or N), the third else statement would have taken effect.

Here is a program that plays a simple guessing game with its user, testing for the correct response by use of the if statement. If the user types the letter e, the program points to it and announces, "You guessed it!"

```
/*--- if3.c Illustrate the if and break statements ---*/
#define EOF -1
main()
{
```

THE NEW DAS SERIES 500 FOR THE IBM PC:

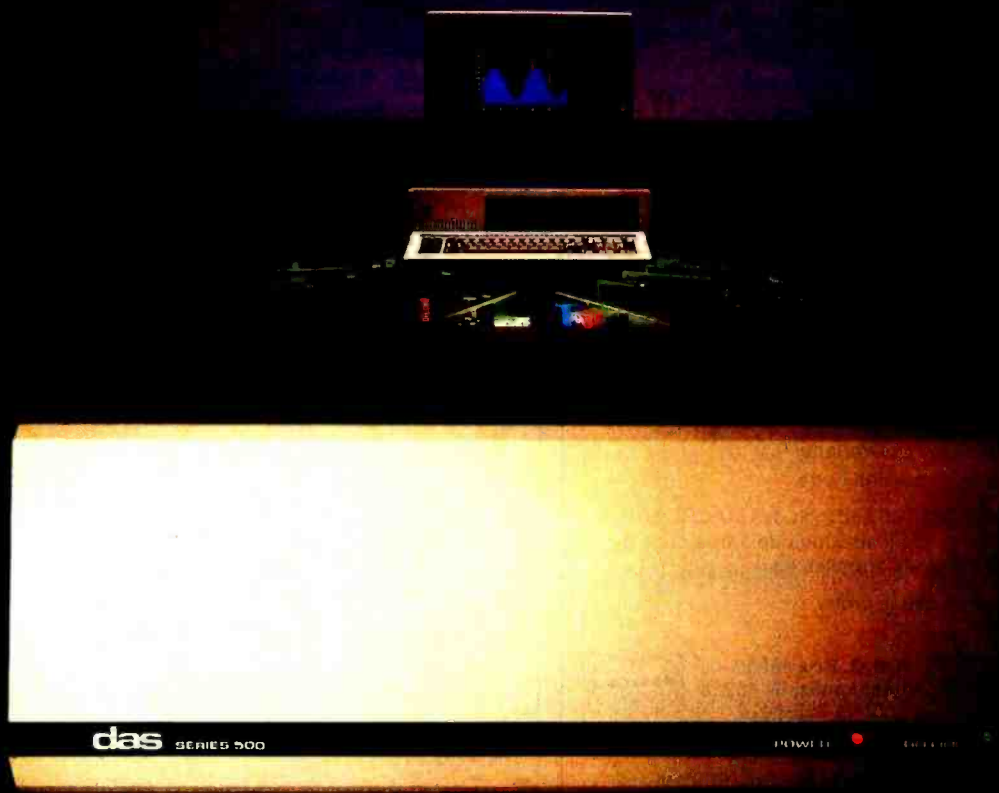

THE DATA ACQUISITION & CONTROL SYSTEM YOU SHOULD CONSIDER OVER A MINI. EVEN IF MONEY IS NO OBJECT.

Let's say you have enough money to buy nearly any data acquisition and control system you might want. What will you choose?

If sheer power is your main requirement, you might choose an expensive minicomputer system. But, then again, you might just as well choose the new DAS Series 500.

Simply plug the Series 500 into any off-the-shelf IBM Personal Computer and you'll have up to 336 channels of analog input, 60 channels of analog output and 192 channels of digital I/O (even AC/DC device control). And with measurement speeds as high as 25,000 analog data points per second, and true 12 or 14 bit precision, you'll have enough power and accuracy for the most demanding applications.

If you need flexibility, you'll want to compare other, more costly systems to the fully modular Series 500. It comes supported by an extensive library of integrated plug-in modules that let you custom tailor almost any

combination of inputs and outputs, digital or analog. And do so almost instantly.

So the Series 500 is ideal for hundreds of applications in product test, process control and energy management; in psychology, biology, analytical chemistry and neuroscience.

If ease of use is high on your list, consider this: Only the Series 500 comes equipped with the advanced, integrated Soft500 software package. With it, you can set up, collect, store, control, display and analyze, all with a few simple BASIC commands.

In fact, Soft500 makes programming so easy, you can be up and running with your Series 500 the same day you get it. Even if you're not a computer expert.

Now compare advanced features. Like exclusive foreground/background software architecture that lets you analyze data while you collect it. Like the real-time clock/calendar and precision interval timer.

Or the tremendous range of signal conditioning options, including software selected gain and offset, amplification from millivolt levels, and provision for direct connection of thermocouples, strain gauges and RTDs.

These are features you might not get elsewhere, no matter how much money you spend. But then, why spend all that money?

Because for less than \$6000 you get both the advanced capabilities of the DAS Series 500, plus an IBM PC[®] (which incidentally, you can still use to do all the other things a PC does so well).

For complete information on the DAS Series 500 data acquisition and control system, write to us at Data Acquisition Systems, Inc., 349 Congress Street, Boston, Massachusetts 02210. Or call us at 617 423-7691.



IBM PC[®] purchased separately. Not available for the Apple II. IBM PC[®] & Apple II are registered trademarks.

Eco-C TM Compiler

Since November of last year, we've been testing our new Eco-C Compiler and now it's ready for your Z80™ CP/M™ system. Some of the features include:

- All data types, including float, double and long.
- Fast, efficient code. For example: Our versions of "seive" in January, 1983, BYTE; 15.8 seconds (standard) and 11.7 seconds (optimized).
- Uses Microsoft's MACRO 80™ for REL file output.
- Standard (K&R) file I/O and library (most in source) included.
- Easy assembly language interface.
- No royalty fees on generated code.

The price for Eco-C is \$350.00 and includes MACRO 80 (a \$200.00 value by itself). We'll also include a free copy of *C Programming Guide* while supplies last.

For further information, call or write:



P.O. Box 68602
Indianapolis, IN 46268
(317) 255-6476

Registered trademarks are: Zilog (Z80), Digital Research (CP/M), Microsoft (MACRO 80) and Ecosoft (Eco-C).

```

int byte;

greet();

while ((byte = getchar()) != EOF) {
    if (byte == 'e') {                /* D */
        printf("^—You guessed it!\n"); /* E */
        break;                        /* F */
    }                                  /* G */
    putchar (byte);
}                                     /* H */

greet() /*--- Print a greeting to the user ---*/
{
    printf("If you type a certain letter\n");
    printf("I'll congratulate you for guessing it.\n");
    printf("If you get bored, type control-d instead.\n");
}
    
```

The brace at the end of line D indicates that a compound statement follows, just as a brace introduced a compound statement in previous examples. The closing brace for the if is on line G and is directly under the i of the if.

The statements on lines E and F are executed if the character entered was an e. The first not only congratulates the user on the correct guess but points to the correct letter on the line the user typed. (This extra touch is meant to suggest a level of human interface being found in more and more programs and is by no means state of the art. For example, if your erase character is # and you erase characters before typing the correct one, the arrow will be meaningless. Try rewriting this example to get around this problem. Next month, in the section on character arrays, I will present some ideas that may be helpful.)

The break on line F is a powerful statement in C. It causes the program to break out of the first enclosing while, for, do, or switch (I've omitted discussion of the do statement here but will present switch in part 2), passing control to the statement following. In this case, the break causes the while to release control, with processing resuming just after the brace on line H, so the program next reaches the closing brace for main and ends.

We have wandered through C programs to learn C program structure, C functions within programs, basic input/output in C, variables and assignment of value, and control constructs such as while, for, if, and else. With these five aspects of C you can write useful programs so long as you are processing one character at a time.

Next month in part 2 we will take up the more advanced topics of arrays, pointers, communication between C programs and the host operating system, and the important concept of tool building. ■

James Joyce is president of International Technical Seminars Inc. (520 Waller St., San Francisco, CA 94117) and founder of the Unix Bookstore.



more megabytes

The MARK SERIES WINCHESTER DISK DRIVE SUBSYSTEMS

30 Ms. Average Access
1 Year Parts & Labor Warranty

- 20 MEGABYTES...\$3,333*
- 33 MEGABYTES...\$3,750*
- 46 MEGABYTES...\$4,416*

DSS SERIES WINCHESTER DISK DRIVE SUBSYSTEMS

85 Ms. Average Access
90 Days Parts & Labor Warranty

- 5 MEGABYTES...\$1,995*
- 10 MEGABYTES...\$2,295*
- 15 MEGABYTES...\$2,695*

COMPATIBILITY

Hardware and Software interfaces for TRS-80®, Apple II®, IBM-PC® CP/M®, Turbodos® S-100, any 8 bit parallel port, any Z-80® computer such as Osborne®, Xerox®, Televideo®, Northstar Advantage®, NEC®, AVL-Eagle®

NOTHING ELSE TO BUY

Subsystems include disk, chassis with power supply, controller, cables, hardware adapter and software package.

*SUBSTANTIAL DISCOUNTS AVAILABLE TO QUANTITY BUYERS.

PH ASSOCIATES 8720 Old Courthouse Rd.
Vienna, VA 22180 • 703-281-5762

20/20 FORESIGHT

Right in any light. Comrex word processing monitors.

Fluorescent. Incandescent. Natural. Artificial. Comrex has word processing monitors for any kind of light. The CR-5400: a compact, nine-inch diagonal screen; the CR-5600: a twelve-inch screen. Both available in green, yellow-green or amber displays with tack-sharp resolution. Easy on the eyes. Both so affordable they could only come from Comrex. Easy on the wallet. The CR-5400.

The CR-5600. The monitors for your eyes,
your lighting, your wallet, you.

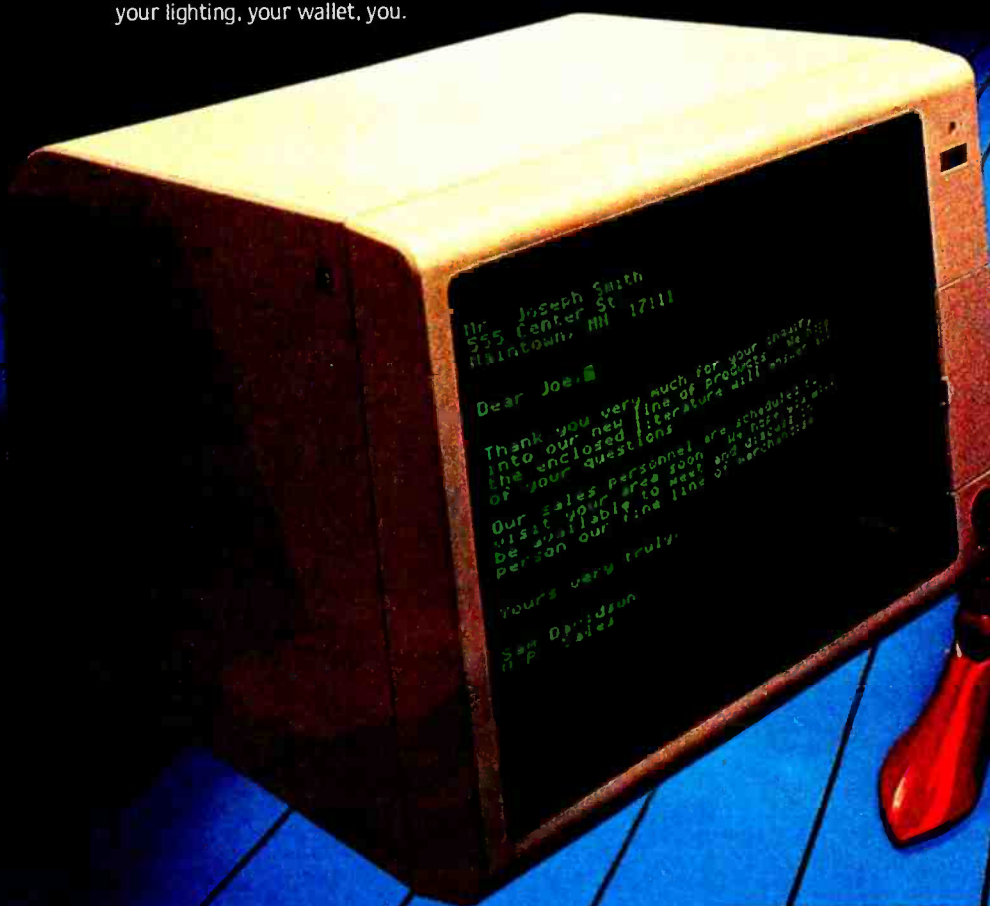

COMREX

INTERNATIONAL INCORPORATED
3701 Skypark Dr. • Suite 120 • Torrance, CA 90505 • (213) 373-0280





The IBM Personal Computer XT. More power to the person.

Plenty of muscle. That's what the new IBM Personal Computer XT means to a person with heavyweight data to manage. Because one of the XT's many strong points is a 10-million-character fixed disk drive that helps give you the power to pump more productivity into your business.

What's so special about a fixed disk? Exactly that. It's *already* fixed inside the system, with the capacity to store the facts, figures, names and numbers you need to work with.

(Rather than go from diskette to diskette, store up to 5,000 pages of text or up to 100,000 names and addresses in one place.)

Yet there's more built into the XT than its fixed disk. Reliability and quality are built in as well. Plus more than 30 years of IBM experience.

A new level of price/performance.

And a remarkable compatibility of both software *and* hardware with the original IBM Personal Computer. So, with the introduction of XT comes a special tool designed to help you be more productive in high-volume applications.

WHAT'S THE DIFFERENCE?

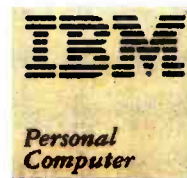

BASE SYSTEM*
User Memory
64KB (expandable to 640KB)

Auxiliary Memory
Up to two 5¼" 160KB/180KB or
320KB/360KB diskette drives
optional



BASE SYSTEM*
User Memory
128KB (expandable to 640KB)

Auxiliary Memory
One 10 megabyte fixed disk
drive and one 5¼" 360KB
diskette drive standard

*An expansion unit can also be added to both 16-bit (8088) systems for 6 more system expansion slots. Added to the IBM Personal Computer, it can house two 10 megabyte fixed disk drives. Added to the IBM Personal Computer XT, it can house one additional fixed disk drive for a total of 20 megabytes.

Another tool for modern times to
keep you going strong.

To find out where you can see the
IBM Personal Computers, call 800-447-4700.
In Alaska or Hawaii, 800-447-0890.

Comparing C Compilers for CP/M-86

Portability, compactness, and speed are crucial

by Jerry Houston, Jim Brodrick, and Les Kent

The very number of C compilers available attests to the strong position C has taken as the shift toward 16-bit microprocessors picks up momentum. The popularity of Intel's 8086 family of microprocessors (in combination with Digital Research's CP/M-86, MP/M-86, and Concurrent CP/M-86) prompted us to wonder, of the C compilers currently available for these systems, which are best for a particular purpose, which are most cost-effective, and which are easiest to use? Portability, compactness, and speed are crucial, but so are completeness of implementation and the extent to which the compilers make special allowances for the architecture of the 8086 processor family and the structure of CP/M.

Why C?

Long revered in the halls of academe, C has recently become a significant language in professional circles. C is fast, efficient, versatile, and, perhaps more than any other significant language, portable. C's tendency to reduce projects to a collection of discrete functions is well suited to joint programming efforts and produces code that is easy to maintain.

In the rush to migrate to 16-bit processors, software houses are turning to C in droves (see the text box "The 16-Bit Migration," page 84). It has qualities in addition to its speed that make it particularly suited for systems programming (e.g., flexible pointers and efficient use of registers). Thomas Plum in *Learning to Program in C* (Cardiff, NJ: Plum Hall Inc., 1983) calls it "a portable assembler." Yet, C nicely accommodates applications programming by inducing

new CP/M operating systems will be written in C.

A great attraction of the Digital Research family of operating systems is that it spans the gap between 8- and 16-bit processors. In other words, a data file that can be read on an 8-bit CP/M system can also be read on a 16-bit one. And DRI has announced that future versions of CP/M will support National Semiconductor's 16032 and Zilog's Z8000 microprocessors.

Evaluation Philosophy

We approached our evaluation of six C compilers (Mark Williams CC86, Digital Research C, Computer Innovations C86, Mark DeSmet C, Lattice C, and Supersoft C) with a slant toward identifying their suitability for use by a systems house because we work for one. (That means we make operating computers out of a lot of interconnected parts.) We are more interested in using C as a systems language to produce device handlers, formatters, diagnostics, and utilities than we are in using it to produce accounting programs and database managers.

In evaluating these compilers, we have chosen *The C Programming Language* by Brian W. Kernighan and

**Our evaluation is
slanted toward
identifying the
suitability of these six
C compilers for use by
a systems house.**

its users to practice structured programming techniques.

One software house newly committed to the C language is Digital Research Inc. (DRI), whose CP/M operating system dominates the 8-bit world and whose operating systems are a major force in the 16-bit world. DRI has announced that, in order to achieve source-code portability, all

The 16-Bit Migration

The microcomputer industry is going through a software cataclysm that has no parallel in the minicomputer world. Three major manufacturers—Intel, Motorola, and Zilog—have all produced 16-bit processors that are incompatible at the object-code level with their popular 8-bit counterparts. A fourth manufacturer, National Semiconductor, with no significant 8-bit following, has produced yet another 16-bit orphan.

In the minicomputer world, this would have been considered a classical, almost comical, marketing error: an entire generation of processors has been cut off. Huge user bases with millions of man-hours of software development and user training have been abandoned during the industry's transition from 8 to 16 bits.

This situation has sparked a great migration. Masses of software are suddenly being uprooted from their 8-bit homes by a relentlessly advancing technology and forced to resettle in strange and hostile

16-bit lands dominated by the 8086, the 68000, the Z8000, and the 16032.

Operating systems, peripheral drivers, languages, and application programs are struggling to reestablish themselves in new, fiercely competitive environments. The reward for the first products to make a successful transition from 8 to 16 bits will be what marketing sages call "positioning"—which translated means popular acceptance, loyal followers, a place in the sun. The penalty for delay is catastrophe.

The migration path must be well chosen. Companies with products written in assembly language are finding that their fast, sleek 8-bit code, which took so long to write and debug, will require a frightening amount of time to be reproduced in a 16-bit environment. The time spent in a major assembly project costs more than programmers' salaries. The major cost is in lost opportunity.

Even more dismaying for the assembly-language folks is that their programs will

have to be translated anew for, not just one, but a whole flock of attractive target processors: the 8086, the 68000, the Z8000, and the 16032. Which one would you bet on? Would you bet your company on just one of them?

The great advantage of assembly language—speed and compactness—is a luxury few can afford now that nearly all software projects are time critical. In this virgin market, you don't need fast products; you need products fast.

Companies with products written in exotic, high-level languages like PL/I, on the other hand, are in a slightly better situation. The development time spent on their 8-bit products will carry over to 16-bit versions, which should require no more than a little fine-tuning to become marketable. These companies need only sit back and wait for 16-bit versions of their chosen compiler to be released. Yep, just sit back and wait, and wait. . . .

Dennis M. Ritchie (Prentice-Hall Software Service, 1978) as the standard definition of the C language. (In an attempt to buck convention, we will try to avoid the use of the word "robust" and will resist all temptations to make puns about C.)

The Procedure

We have tested the six C compilers that are currently commercially available for the CP/M-86 operating system (although by the time this article is published, we expect four more to become available). To evaluate the speed of each compiler, we selected five benchmarks—each chosen to test a certain range of C language features. Not all the compilers were able to run all the benchmarks. After spending many hours trying to find source code that was common to all the compilers, we finally decided that documenting the inability to compile a legitimate program provides useful information about a compiler.

These benchmarks were performed on a Compupro system with a 10-MHz 8086 and a 4-megabyte semiconductor disk emulator (Compu-

pro's MDrive/H). The 8087 floating-point benchmarks were run at 5 MHz to allow for the slower speed of the 8087 math processor. The operating system used was our own implementation MP/M-86.

The Sieve of Eratosthenes Is a mandatory benchmark—If nothing else, it tests a compiler's ability to perform loops.

The four performance categories we measured (see table 1) in these benchmarks were (1) compile time on a floppy disk and on a disk emulator (or memory drive), (2) link time on a floppy disk and on a disk emulator, (3) absolute size of executable object code produced, and (4) execution time of compiled code (run on a disk emulator).

For the first three benchmarks, we also measured the effective size of the

code generated by each compiler. We derived this value by measuring the absolute size of the code produced by compiling a program with only an empty printf function call—the only function call used in the first three benchmarks. We then subtracted this value from the size of the absolute code produced by the benchmark in question. The resulting value represents the amount of incremental code generated to run the specific benchmark.

Using the effective code size gives a much more accurate picture of a compiler's code-generation efficiency than merely looking at the size of the executable file created by compiling a given benchmark. The size of the fixed portion of a program may indicate only how elaborate the library is. As your C programs grow larger, only the amount of incremental code will increase. (Note in table 1, for example, that, although the command files produced by the DRI compiler are bigger than the Computer Innovations files, Digital Research has an edge in effective code size. This suggests that the DRI compiler will

Dysan Software Duplication:

It's your name on the package label. And your company's reputation on the line. Whether your program retails for \$40.00 or \$400.00, or is for company internal distribution, the cost of duplicating it on diskettes is just a fraction of the value of your product. Doesn't it make sense to protect the time, money and talent invested in your software with the finest and most complete software duplication services available?

Quality Software Deserves the Quality Media.

Dysan's software duplication services are unsurpassed for fidelity of reproduction. Not only is your program copied unerringly onto the finest media made—the Dysan diskette—but it's also copied on proprietary equipment manufactured by Dysan, exclusively for Dysan. Plus Dysan offers you the widest variety of support services available—from software protection to serialization and packaging.

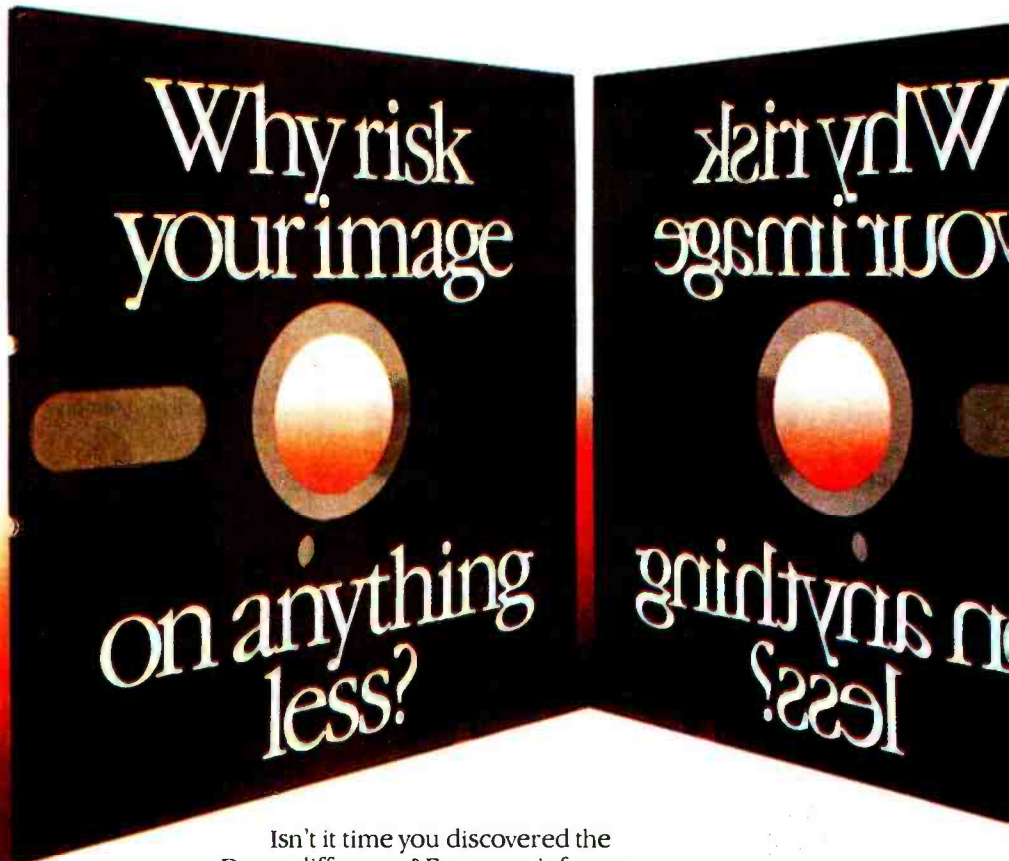

Isn't it time you discovered the Dysan difference? For more information on Dysan software duplication, fill out and return this coupon today, or call (800) 551-9000.



Circle 153 on Inquiry card.



Dysan Software Duplication Division
5201 Patrick Henry Drive
Santa Clara, CA 95050
(800) 551-9000
(408) 988-3472

Please send me more details on
Dysan's Software Duplication Services.

BB
Name: _____
Company: _____
Address: _____
City: _____ State: _____ Zip: _____
Phone: () _____

actually produce smaller programs than Computer Innovations C86 once the source program reaches a certain size.)

Quick Results

The sieve benchmark in listing 1 is a mandatory test (used by Jim and

Gary Gilbreath in "Eratosthenes Revisited: Once More Through the Sieve," in the January 1983 BYTE, page 283); if nothing else, it tests a compiler's ability to perform loops. All C compilers we tested ran this program, even if they ran no other. Lattice C was the undisputed cham-

pion in this classic benchmark, taking just 3.6 seconds to complete 10 iterations. Digital Research's C compiler for the 68000 performed this test in 6.0 seconds on an 8-MHz 68000 system, which would put it in fourth place, 1.1 seconds behind the Digital Research 8086 C compiler.

Not all the C compilers that we tested support floating-point operations. Of those that do, not all support the transcendental functions (trigonometric, logarithmic, exponential, etc.). Thus, the philosophy behind the floating-point benchmark (see listing 2) is to keep things simple and minimize the time spent looping; the only floating-point operations we measured were multiplication and division.

Comparison of the compilers' mathematical ability is complicated by Intel's phenomenal math processor, the 8087. While it meets the IEEE's (Institute of Electrical and Electronics Engineers) 80-bit floating-point standard and is potentially as much as 100 times faster than equivalent software, the peculiarities of Intel hardware design require that the processor with which the 8087 is paired run at the same clock speed. The fastest 8087 currently available in production quantities runs at 5 MHz, yet 8088s that run at 8 MHz are readily available, as are 10-MHz 8086s. This means that the main processor must be slowed down by as much as 50 percent, incurring a corresponding loss in system throughput, in order to take advantage of the 8087 math processor.

With systems capable of handling high-speed processors, you must decide whether going faster while number crunching (between 7 and 10 times faster on the compilers tested) is worth sacrificing as much as half your speed while doing anything else. Lattice C was the "pure-software" winner, running the floating-point benchmark in 95 seconds by itself, but Digital Research's compiler, with the aid of an 8087, was an order of magnitude faster than that. (An advantage of the IBM Personal Computer is that its 8088 processor runs at about 4.77 MHz, so that the decision to add an 8087 is

Program: sieve.c							
Compiler	Compile Time		Link Time		Code Size		Execution Time
	Floppy	Memory	Floppy	Memory	absolute	effective	Memory
Lattice	23	4	60	10	9,984	128	3.6
Mark DeSmet	20	3	32	5	4,992	128	4.1
Digital Research	32	8	64	12	13,888	144	4.9
Mark Williams	29	6	67	22	7,744	144	6.2
Computer Innovations	31	7	49	20	11,888	208	9.4
Supersoft	253	142	266	148	5,200	416	12.0

Program: sort.c							
Compiler	Compile Time		Link Time		Code Size		Execution Time
	Floppy	Memory	Floppy	Memory	absolute	effective	Memory
Mark Williams	45	12	84	22	8,320	720	50
Mark DeSmet	35	9	49	11	5,376	512	66
Lattice	36	6	82	15	10,496	640	79
Computer Innovations	46	15	71	38	12,416	736	146
Digital Research	43	14	59	12	14,432	688	199

Program: fibo.c							
Compiler	Compile Time		Link Time		Code Size		Execution Time
	Floppy	Memory	Floppy	Memory	absolute	effective	Memory
Mark DeSmet	21	3	32	5	4,992	128	14
Lattice	21	4	60	11	9,984	128	15
Mark Williams	32	6	66	15	7,712	112	17
Supersoft	238	141	251	146	4,960	176	19
Computer Innovations	32	7	50	13	11,808	128	22
Digital Research	37	9	55	12	13,856	112	25

Program: float.c							
Compiler	Compile Time		Link Time		Code Size	Execution Time w/o 8087	Time w/8087
	Floppy	Memory	Floppy	Memory			
Lattice	22	4	65	11	11,136	95	n/a
Mark DeSmet	22	3	34	5	5,248	108	15.5
Digital Research	35	9	60	13	15,824	116	11.8
Mark Williams	34	8	70	25	8,320	167	n/a
Computer Innovations	29	6	48	19	12,080	278	32.6

Program: lofile.c							
Compiler	Compile Time		Link Time		File Size Code	Execution Time	
	Floppy	Memory	Floppy	Memory		Floppy	Memory
Lattice	31	7	72	14	10,496	218	29
Mark DeSmet	26	4	39	7	9,856	592	37
Mark Williams	43	11	78	20	8,624	654	40
Digital Research	42	13	60	13	16,928	656	64
Computer Innovations	37	11	56	19	13,200	682	76

Table 1: Results of the benchmark tests.

YOU ARE UNBEATABLE



WITH THE CYBERNETICS TWINS!!

...**RAM/COBOL**¹ and **(RT)**². The combination provides a uniquely powerful set of business software tools.

RAM/COBOL IS THE MOST WIDELY-USED MICROCOMPUTER COBOL...and for good reason. Highly compatible across the widest range of micro/mini/mainframe computers, it is the language of choice for serious business applications. With the release of **RAM/COBOL** for the IBM mainframe machines (370, 30xx, 43xx), it is now possible to have compatibility over a truly huge range of computing power...**from micros to mainframes.**

(RT) from Cybernetics (COBOL Reprogramming Tool!) is a source program generator for **RAM/COBOL**, that can automatically produce a wide range of file maintenance, report printing, and other types of **RAM/COBOL** source programs. Programs produced by **(RT)** provide a flexible alternative to many "database" software packages, since generated source programs may be modified for special requirements if desired. All source programs produced by **(RT)** are, of course, the property of the user of **(RT)**!

In addition to the Cybernetics twins, **RAM/COBOL** and **(RT)**, we offer source program licenses for the most comprehensive microcomputer business applications...the MBSI Realworld³ software written in **RAM/COBOL**. Starting life as the minicomputer-based MCBA⁹ business applications, this software brings a new degree of professionalism to microcomputer applications.

Our software is available and supported for a wide range of microcomputer operating systems including CP/M⁴, CP/M-86⁴, MP/M⁴, MP/M-86⁴, PC DOS, MSDOS⁵, OASIS⁶, TRSDOS⁷, UNIX⁸, and RMCOS¹. Contact us for details.

**CALL NOW.
(714) 848-1922**

Trademarks of:
 1 - Ryan-McFarland Corp.
 2 - Cybernetics, Inc.
 3 - Micro Business Software, Inc.
 4 - Digital Research, Inc.
 5 - Microsoft, Inc.
 6 - Phase One Systems, Inc.
 7 - Tandy Corp.
 8 - Bell Telephone Laboratories
 9 - Mini Computer Business Applications, Inc.

available for:

IBM	TEXAS INSTRUMENTS	NEC
TELEVIDEO	HEWLETT-PACKARD	DELTA
DIGITAL EQUIPMENT CORPORATION	TOSHIBA	
EPSON	HEATH	ONIX
		NORTHSTAR
		IMS
KEROX	RADIO SHACK	COMMODORE
		SPERRY UNIVAC
SHARP	SANYO	OLIVETTI
		APPLE
		CORVUS
INTEL	CALIFORNIA COMPUTER SYSTEMS	COMPAQ
		COMPAC
WANG	SD SYSTEMS	PLEXUS
		VECTOR
		MOLECULAR
		ENGLI
		DATAPOINT
		CONRAD



8041 Newman Avenue
 Suite 208
 Huntington Beach, CA 92647
 (714) 848-1922

© Copyright 1983 by Cybernetics, Inc. all rights reserved.

Listing 1: The Sieve of Eratosthenes benchmark developed by Jim and Gary Gilbreath as a standard for comparing the speed of various computer systems.

```

/* Eratosthenes Sieve Prime Number Program in C from Byte January 1983 */

#define true 1
#define false 0
#define size 8190

char flags[size+1];
main ()
{
    int i,prime,k,count,iter;

    printf("10 iterations\n");
    for(iter = 1; iter <= 10; iter++) /* do program 10 times */
    {
        count = 0; /* prime counter */
        for (i = 0; i <= size; i++) /* set all flags true */
            flags[i] = true;
        for (i = 0; i <= size; i++)
        {
            if (flags[i]) /* found a prime */
            {
                prime = i + i + 3; /* twice index + 3 */
                printf ("\nd", prime); /*
                for (k=i+prime; k<=size; k+= prime)
                    flags[k] = false; /* kill all multiples */
                count++; /* primes found */
            }
        }
    }
    printf("\nd primes.", count);/* primes found on 10th pass */
}

```

Listing 2: Floating-point benchmark. This simple program tests the speed of floating-point functions in C compiler libraries. Compared to the number of multiplications and divisions in this program, the time spent executing the looping instructions is insignificant.

```

/* simple benchmark for testing floating point speed of c libraries
does repeated multiplications and divisions in a loop that is
large enough to make the looping time insignificant
*/

#define CONST1 3.141597E0
#define CONST2 1.7839032E4
#define COUNT 10000

main ()
{
    double a, b, c;
    int i;

    a = CONST1;
    b = CONST2;
    for (i = 0; i < COUNT; ++i)
    {
        c = a * b;
        c = c / a;
        c = a * b;
        c = c / a;
        c = a * b;
        c = c / a;
        c = a * b;
        c = c / a;
        c = a * b;
        c = c / a;
        c = a * b;
        c = c / a;
        c = a * b;
        c = c / a;
        c = a * b;
        c = c / a;
    }
    printf ("Done\n");
}

```

simply a budgetary one.)

A word about future processors and the 8087: Intel has announced a solution to this problem in the design of its new 80286 processor, which runs at a clock speed different from that of its 80287 math coprocessor. According to Intel, the 80286, which can execute all 8088 and 8086 instructions, can execute those instructions up to six times faster than the 8086 (a conservative figure might be four times faster). Perhaps soon, the first significant digit in our benchmark times will be behind a decimal point.

The sort program in listing 3 is designed as a general test of compiler efficiency. It uses a random-number generation algorithm to produce an array of long integers, which are then sorted using a quicksort algorithm. The Mark Williams CC86 compiler won this benchmark by a significant margin.

The Fibonacci number generator in listing 4 is a reasonably good test of recursive function calls. This benchmark, which saw Mark DeSmet C barely edge out Lattice C for first place, had the tightest performance grouping of any of the benchmarks run. The Digital Research 68000 C compiler performed this benchmark in 16.8 seconds, which earned it a third place, 7 seconds ahead of DRI's 8086 C compiler.

The efficiency of low-level (unbuffered) file I/O (input/output) is tested by the program in listing 5. It almost turned out to be the "unbenchmark." We had to struggle to come up with code that most of the compilers could handle. The Lattice and Mark DeSmet Cs wouldn't run this benchmark as it was initially written using high-level I/O functions because these Cs only support low-level disk I/O. When we changed the benchmark to low-level operation, Mark Williams C dropped out because it uses only high-level I/O.

Originally the program wrote 128K bytes onto the disk, but a bug in our (beta release) DRI compiler would not allow writing of files over 64K bytes long, so we changed the file size to just under 64K bytes. The Supersoft compiler couldn't handle the long data types—a problem we

Text continued on page 94



You win.

Put your money on NEC's new PC-8800 personal computer and you're automatically a winner.

You win with your choice of state-of-the-art hardware, including a full range of high-quality peripherals.

You win with advanced, user-friendly software, including programs for all types of banking, accounting, and business management.

You win again with NEC's high-quality graphics. And our reputation for reliability gives you as close to a sure thing as you can get.

So use a little horse sense and stack the odds in your favor for once. With the PC-8800 from NEC Home Electronics.



Your choice of hardware:

- 8-bit or 16-bit processor
- 5-1/4" or 8" disk drive
- High-speed dot matrix or letter-quality printer.

Free software with complete system:

- WordStar[®] word processing
- MailMerge[®]
- Multiplan[™] spread sheet
- BASIC (two versions)
- CP/M[®]

NEC Home Electronics (U.S.A), Inc. Personal Computer Division

1401 Estes Avenue
Elk Grove Village, IL 60007

NEC Corporation, Tokyo, Japan

EXTRA**EXTRA**

S-100 World News

MACROTECH International Corporation

20630 Lassen Street, Chatsworth, California • 213-700-1501

NOW 1 MEGABYTE *MAX* FOR ALPHA MICRO

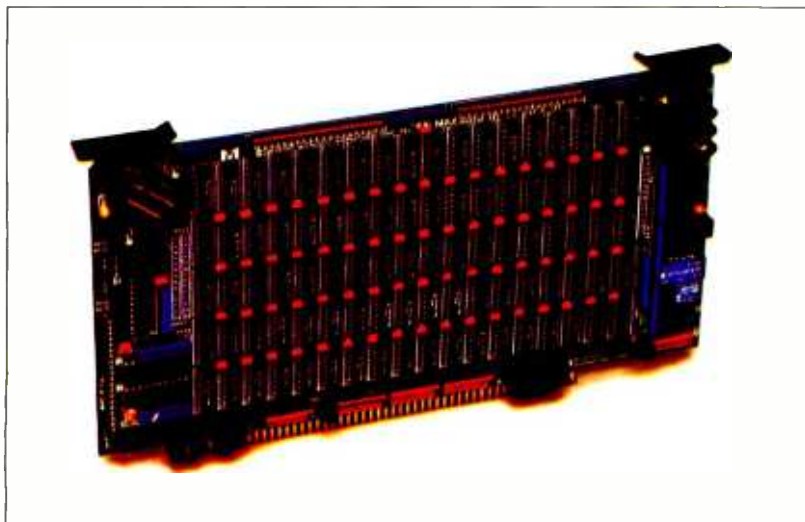

CHATSWORTH—June 30, 1983—Mike Pelkey, Macrotech International President, announced today that a special version of *MAX* is now running in Alpha Micro Systems.

This special version is available only through Soft Machines of Champaign, IL. (217) 351-7199. Howard Ogle of Soft Machines stated, "The new *AM-MAX1* runs full speed with all three Alpha S100 machines." Ogle also said, "The *AM-MAX1* is not only the most economical memory for Alpha, but the most versatile as well. The system is even faster with Soft Machines' 'GO FAST' disk cache utilities!"



HOWARD OGLE

Bob Rubendunst of Soft Machines reports, "Every *MAX* is shipped with software that greatly simplifies implementation on bank switched systems. Also included are detailed installation instructions and diagnostic programs."

Dealer inquiries and orders should be directed to Bob at Soft Machines. **M**

VIRTUAL DISK NOW NONVOLATILE

CHATSWORTH—June 30, 1983—Mike Pelkey announced today the release of the latest addition to the Macrotech product family. The **B-Board** is a multifunction system support board, for use with *MAX* and *128ST* memories. Used with the *128ST*, this combination creates a complete disk emulation, including nonvolatility. The **B-Board** features include battery backup, power fail monitor, and charging circuitry for on or off board batteries.

The **B-Board** functions also include a time-of-day clock, using a National Semi device for hassle free operation. It also gets early warning at power down, so the time-of-day can't suddenly get creative. An interrupt is available which can be used to turn the system on or off at a preset time.

On board ROM space accepts the users'

EPROM based program storage. It can be configured to accept one or a pair of any EPROM type from 2716 to 27256, in 8 or 16 bit format. It supports a wake up jump option with full or shadowed phantom overlay.

The **ERROR TRAP** feature is designed to support the parity error detection feature of the *MAX* series dynamic memories. Any activity on the system's **ERROR** line causes the trap to record the extended address and data busses and 20 bits of bus status information. Up to 16 events can be trapped; the trap issues an interrupt when it's full.

The **B-Board** is a logical addition to the growing family of Macrotech International's no-compromise S100 boards for no-compromise users. **M**

MAX Split Personality

BURBANK—June 30, 1983—"Many current operating systems permit *MAX* to double as both virtual disk and system memory," stated Dan West of Westcom Systems. As an example, an MP/M 2.1* system using *MAX-M* could be configured as a 512K system memory and a 512K Vdisk. A typical CP/M 3.0* configuration could be 256K of system memory and up to 768K Vdisk. CP/M 2.2* of course, only permits a 64K system memory, leaving the balance for a virtual disk. With *MAX*, or the *128ST*, both functions can run simultaneously in a single memory board. **M**

MACROTECH Moves

CHATSWORTH—June 30, 1983—Macrotech has moved to larger facilities located at 20630 Lassen St., Chatsworth, CA 91311. The new phone number is (213) 700-1501. "Due to a healthier marketplace and a phenomenal demand for the *MAX* series, larger facilities were necessary. This permits additional staffing, increased production, and customer support levels," said Mike Pelkey, President of Macrotech. **M**

Virtual Disk for CP/M 86*

Dan West, Westcom Systems

BURBANK—June 30, 1983—Most of the CP/M 86* application programs available today fail to take advantage of the possible one megabyte address space. Virtual Disk for CP/M 86* will convert this unused space into RAM resident disk capacity for greatly improved disk access processing. The easily installed Virtual Disk 86 software module has been added to Macrotech's applications software available to owners of *MAX* series and *128ST* memory boards. **M**

PRICE INDEX

	SIZE	P/N	PRICE
Static Memory	128K	128-ST	\$1232
Dynamic Memory	256K	MAX-256	\$1108
	384K	MAX-384	1292
24-bit Addressing	512K	MAX-512	1647
	640K	MAX-640	1737
	768K	MAX-768	1815
	896K	MAX-896	1899
	1M	MAX-M	1983
With 16-bit M ³ Addressing option, add \$91			
Software (provided on 8" disk)			
Virtual Disk for MP/M 2.1* and CP/M 2.2*			
CP/M 3.0* Bios modules,			
CP/M memory tests			
			\$ 25
Manuals (sold separately)			
	128/ST		\$ 15
	MAX Technical Manual		15

© 1983 Macrotech International Corporation.

* CP/M 2.2, CP/M 3.0, CP/M 86 and MP/M 2.1 are registered trademarks of Digital Research Inc.

Prices subject to change

Circle 245 on Inquiry card.

www.americanradiohistory.com

Listing 3: The sorting benchmark. This program creates an array of random long integers, then performs a quicksort on them. In this example, the number of elements in the array is set by MAXNUM, and the number of times the program is performed is set by COUNT.

```

/* sorting benchmark--calls random the number of times specified by
   by MAXNUM to create an array of long integers, then does a quicksort
   on the array of longs. The program does this for the number of times
   specified by COUNT.
*/

#include "stdio.h"

#define MAXNUM 1000
#define COUNT 10
#define MODULUS ((long) 0x20000)

#define C 13849L
#define A 25173L

long seed = 7L;

long random();

long buffer [MAXNUM] =(0);

main ()
{
    int i, j;
    long temp;

    printf ("Filling array and sorting %d times\n", COUNT);
    for (i = 0; i < COUNT; ++i)
        {
            for (j = 0; j < MAXNUM; ++j)
                {
                    temp = random (MODULUS);
                    if (temp < 0L)
                        temp = (-temp);
                    buffer [j] = temp;
                }
            printf ("Buffer full, iteration %d\n", i);
            quick (0, MAXNUM, buffer);
        }
    printf ("Done\n");
}

quick (lo, hi, base)
int lo, hi;
long base [];
{
    int i, j;
    long pivot, temp;

    if (lo < hi)
        {
            for (i = lo, j = hi, pivot = base [hi]; i < j; )
                {
                    while (i < j && base [i] < pivot)
                        ++i;
                    while (j > i && base [j] > pivot)
                        --j;
                    if (i < j)
                        {
                            temp = base [i];
                            base [i] = base [j];
                            base [j] = temp;
                        }
                }
            temp = base [i];
            base [i] = base [hi];
            base [hi] = temp;
            quick (lo, i - 1, base);
            quick (i + 1, hi, base);
        }
}

long random (size)
long size;
{
    seed = seed * A + C;
    return (seed % size);
}

```

Circle 285 on Inquiry card. →



Read the fine print.

Improve the output of your present system with a dot-matrix printer from NEC.

For good-looking copy in a hurry, it's hard to beat NEC's hard-working PC-8023A. This is a bi-directional 120 CPS, 80-column printer that can operate in a compressed-print mode to yield 132 columns. Special 2K buffer holds a page of data, so the unit can print while you're typing in something else. Compatible with a wide range of computers, from Apple® to Zenith®.

Compare these features with your present printer:

Tractor and friction feed

Complete ASCII characters plus Greek, math, and graphic characters

Elite, pica, compressed print, proportional spacing, subscript and superscript

Standard parallel Centronics interface, serial optional

Prints clear original and up to three copies simultaneously

*Special cables may be necessary. Contact your local NEC Home Electronics dealer



Productivity at your fingertips

NEC

NEC Home Electronics (U.S.A.), Inc.

Personal Computer Division

1401 Estes Avenue

Elk Grove Village, IL 60007

(312) 228-5900

NEC Corporation, Tokyo, Japan

SERIAL PORT EXPANDER AND MORE



BTA's MODEL 524 MULTI-PORT CONTROLLER is a code activated one to four serial port expander — but that's not all since it has separate and independent UARTS, buffers and handshaking each port can operate with a different configuration, i.e. different baud rates, stop bits, etc. These features also permit two or more devices to communicate with the 524 simultaneously.

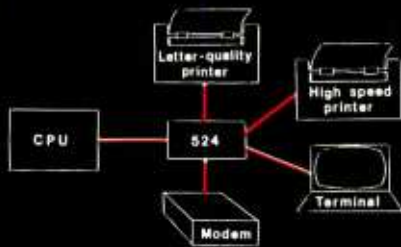

Full duplex with EIA RS-232 protocol

Baud rates up to 19,200

Expansion to 16 ports by cascading

Peripheral ports may be configured by user software

One year warranty



• **MODEL 524** \$249.00

• **MODEL 524A** \$279.00

same as model 524 except has 256 byte rx/tx buffers per port

• **MODEL 524 D** \$269.00

same as model 524, plus continuous polling of each peripheral device for data transfer requests. The device is automatically connected when its 'turn' comes up. ON, BUSY and OFF messages are sent to the peripheral device.

• Other models available — Contact us or your dealer for additional information.

BTA BAY TECHNICAL ASSOCIATES, inc.
 HIGHWAY 803, P.O. BOX 387
 BAY ST. LOUIS, MISSISSIPPI 39520
 (601) 467-8231

Listing 4: The Fibonacci series benchmark. This program tests the efficiency of a compiler's recursion by calculating a 16-bit Fibonacci number.

```
#include "stdio.h"

#define NTIMES 10 /* number of times to compute fibonacci value */
#define NUMBER 24 /* biggest one we can compute within 16 bits */

main()
{
    int i;
    unsigned value, fib();

    printf("%d iterations: ", NTIMES);

    for (i = 1; i <= NTIMES; i++)
        value = fib(NUMBER);

    printf("fibonacci(%d) = %u.\n", NUMBER, value);
    exit(0);
}

unsigned fib(x) /* compute Fibonacci number recursively */
int x;
{
    if (x > 2)
        return (fib(x - 1) + fib(x - 2));
    else
        return (1);
}
```

Listing 5: Disk file I/O benchmark, which sequentially writes a 65,000-byte file on disk. It then uses randomly generated long integers (modulo 65,000) as a disk address, from which it reads, then writes, a random-length string of bytes. This exercises the file I/O functions of the compiler.

```
/* file reading and writing benchmark
sequentially writes a 65000 byte file on disk
generates random long integers
uses these modulo 65000 to read and write strings of ODDNUM bytes
with the file handling system of the c package
the random number generator is set to a specific seed,
so that all compilers should generate the same code
*/

#define ERROR -1
#define READERR 0

#define BEG 0
#define CURR 1
#define END 2
#define READ 0
#define WRITE 1
#define UPDATE 2

#define OKCLOSE 0
#define FILESIZE 65000L
#define COUNT 500

#define C 13849L
#define A 25173L
#define ODDNUM 23
long seed = 7L;

long random (), lseek ();

main ()
{
    int i;
    long j, pos;
    int fd;
    char buffer [ODDNUM + 1];

    if ((fd = creat ("test.dat", WRITE)) == ERROR)
        abort ("Can't create data file\n");
    else
        printf ("File opened for sequential writing\n");
```

Listing 5 continued on page 94

2

You Can't Outrun Memories.

No computer can go faster than its memory.

Even the lightning-fast 68000 processor can be slowed to a snail's pace by a sluggish main memory design.

For that reason, we designed the memory for 16-bit SAGE computers to keep pace with the 68000. It's a close-coupled, straightforward design that lets the processor run full bore at 2 million instructions a second.

Anything less simply wouldn't be state of the art.

Simple Isn't Always Easy.

To make a memory simple is simple.

But to make a simple memory fast is difficult.

And to incorporate it into a computer that doesn't cost a fortune is next to impossible. That is, unless some highly-creative circuit solutions can be found.

And that's precisely how the totally unique SAGE memory was born.

One MBYTE Of 64KBYTE Devices.

In keeping with the no-compromise spirit of SAGE memory design, we

naturally use only 64K, dynamic 150-nanosecond memories. SAGE IV™ computers can be equipped with a megabyte of this type of memory.

And you can specify as few as one or as many as four built-in Winchester, plus floppy drive.

What's more, thanks to its exclusive memory design, your SAGE computer can take data as fast as its floppy disk

can dish it out. In fact, with no need for skewing or interleaving, the SAGE Computer actually lets its floppy run as fast as Winchester do on some machines.

So when you select a computer for serious development or serious business, remember the importance of memory.

For more information and the name of your nearest SAGE dealer, call us today.

Sage Computer Technology, Corporate Office, 4905 Energy Way, Reno, Nevada 89502. Phone (702) 322-6868. TWX: 910-395-6073/SAGE RNO

Eastern United States

Sage Computer Technology, 15 New England Executive Park Suite 120, Burlington, MA 01803 (617) 229-6868

In UK

TDI LTD, 29 Alma Vale Road, Clifton, Bristol BS8-2HL
Tel: (0272) 742796
Tx: 444 653 Advice G

In Germany

MM Computer, GmbH, Hallwanger Str. 59, 8210 Prien
Tel: 08051/3074

Tx: 525 400 mmco-d

p-System standard, supporting Pascal, FORTRAN 77, BASIC and 68000 Micro Assembler. CPIM-68K, Hyper-Forth, Modula 2 optional. SAGE and SAGE IV are trademarks of SAGE Computer Technology.

© 1983 SAGE Computer Technology all rights reserved.

Circle 347 on inquiry card.

SAGE™
COMPUTER TECHNOLOGY

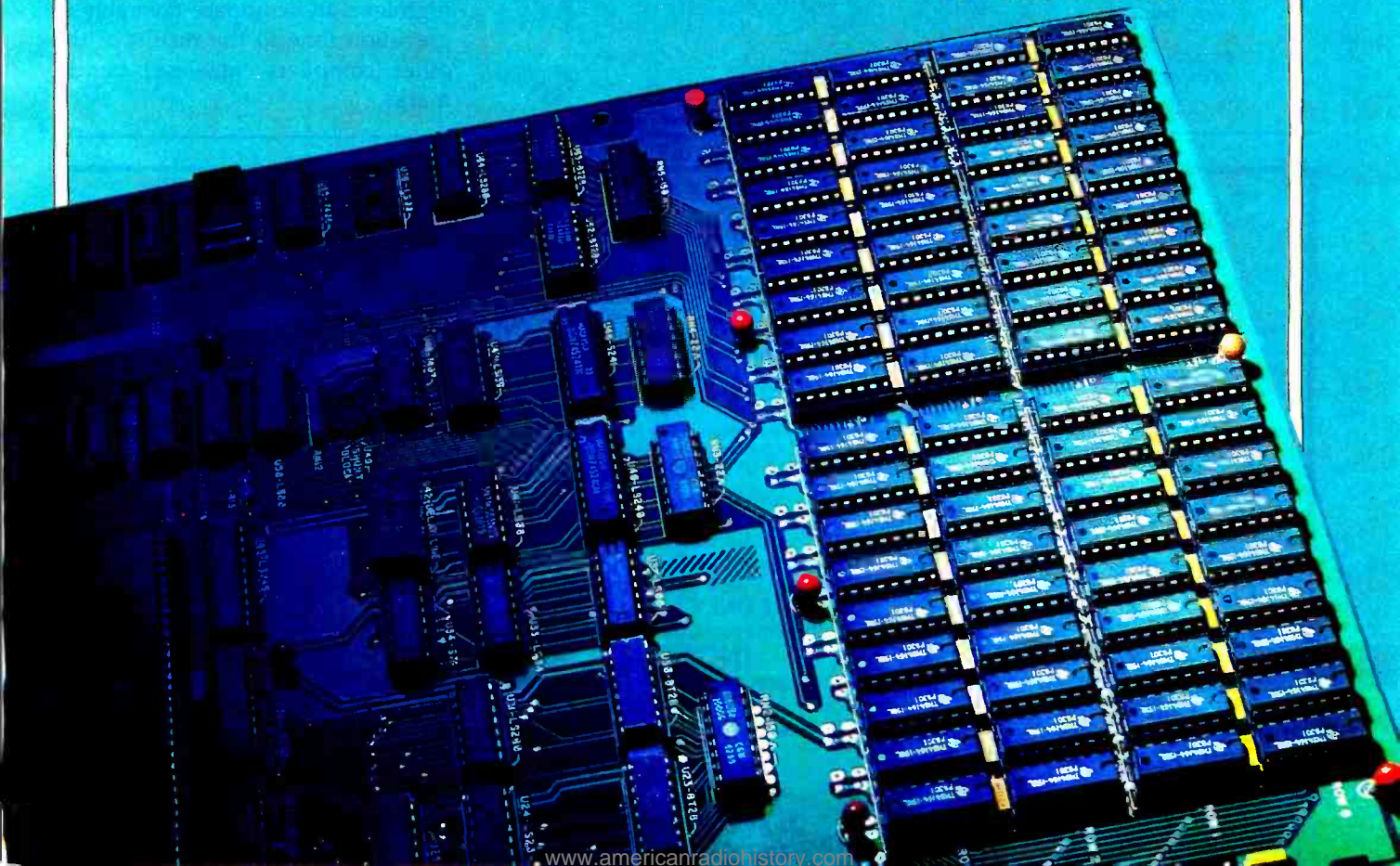

```

for (j = 0; j < FILESIZE; ++j)
    if (write (fd, "x",1) == ERROR)
        abort ("Unexpected EOF in writing data file\n");
if (close (fd) != OKCLOSE)
    abort ("Error closing data file\n");
else
    printf ("Normal termination writing data file\n");
if ((fd = open ("test.dat", UPDATE)) == ERROR)
    abort("Can't open data file for random reading and writing\n");
else
    printf ("File opened for random reading and writing\n");
for (i = 0; i < COUNT; ++i)
    {
    j = random (FILESIZE);
    if (j < OL)
        j = (-j);
    if (FILESIZE - j < ODDNUM)
        continue;
    if ((pos = lseek (fd, j, BEG)) == -1L)
        abort ("Error seeking to random offset\n");
    if (read (fd, buffer, ODDNUM) == READERR)
        abort ("Error reading at random offset\n");
    j = random (FILESIZE);
    if (j < OL)
        j = (-j);
    if (FILESIZE - j < ODDNUM)
        continue;
    if ((pos = lseek (fd, j, BEG)) == -1L)
        abort ("Error seeking to random offset\n");
    if (write (fd, buffer, ODDNUM) == READERR)
        abort ("Error writing at random offset\n");
    }
if (close (fd) != OKCLOSE)
    abort ("Error closing data file\n");
else
    printf("Normal termination from random reading and writing\n");
}

long random (size)
long size;
{
seed = seed * A + C;
return (seed % size);
}

abort (message)
char *message;
{
printf (message);
exit (ERROR);
}

```

could see no easy way around—so it sat on the bench.

Because the Mark Williams compiler does not support low-level I/O, we compiled a special version of the program that has the same algorithm but uses high-level function calls (fread instead of read, fwrite instead of write). We assumed that this would be slow but would at least work. Amazingly, Mark Williams C finished third. Scoring a hat trick, Lattice took this benchmark as well.

Let's take a closer look at the compilers (see also table 2).

Mark Williams CC86

CC86 has the most professional feel of any package we tested. It makes a good attempt at full Kernighan and Ritchie and Unix version 7 compatibility. Of all the compilers, CC86 is by far the most efficient at using buffered I/O functions such as fopen, fread, and fseek (high-level I/O functions). On the other hand, CC86 does not support low-level file I/O (i.e., block I/O functions such as open, read, lseek). This decreases its portability (we couldn't run our low-level benchmark) but in no way reduces CC86's ability to function. In fact, CC86's benchmark results in high-level I/O compare favorably in execution time to the results of the other compilers' low-level benchmarks.



The STARCOM
\$450⁰⁰

*AUTO DIAL 300/1200 BPS
*212A COMPATIBLE MODEM
*BUILT-IN SPEAKER

*VERY COMPACT
*EXCLUSIVE TWO YEAR WARRANTY
*COMPLETE COMM SOFTWARE AVAILABLE



The OSCOM
\$520⁰⁰

*The STARCOM is our latest compact, most technologically advanced, 300/1200 BPS, SUPER INTELLIGENT AUTO DIAL MODEM. The STARCOM is our second generation product, utilizing only 3 LSI Chips, packaged in a custom designed reinforced plastic case. With the STARCOM, all you need is a modular wall plug; it requires NO TELEPHONE, simply key in the phone numbers from your Terminal or Microcomputer keyboard and the Modem will do the rest.

*The OSCOM is another New Product designed for the OSBORNE® Computer User. To simplify its use by providing the necessary communication software integrated in the Modem, no more guessing as to which Software to use.

*The SOFTCOM is a Communications Software Package for PC Microcomputer Users.

We Offer Very Generous Discounts To Our Dealers

Call and Place Your Order Today

ORDERS ONLY 1-800-323-2666

For Information Call 312-459-8881

INCOMM

Division of Interbusiness Corporation

115 N. Wolf Road

Wheeling, IL 60090

Now. Tektronix 60 MHz Performance is just a free phone call away!

Wide-range vertical sensitivity: Scale factors from 100 V/div (10X probe) to 2 mV/div (1X probe). Accurate to $\pm 3\%$. Ac or dc coupling.

Two high-sensitivity channels: dc to 60 MHz bandwidth from 10 V/div to 20 mV/div; extended sensitivity of 2 mV/div at > 50 MHz.

Sweep speeds: from 0.5 s to 50 ns. To 5 ns/div with X10 magnification.

Delayed sweep measurements: Accurate to $\pm 3\%$ with single time-base 2213; to $\pm 1.5\%$ with dual time-base 2215.

Complete trigger system. Includes TV field, normal, vertical mode, and automatic; internal, external and line sources; variable holdoff.

Probes included. High-performance, positive attachment 10-14 pF and 60 MHz at the probe tip.

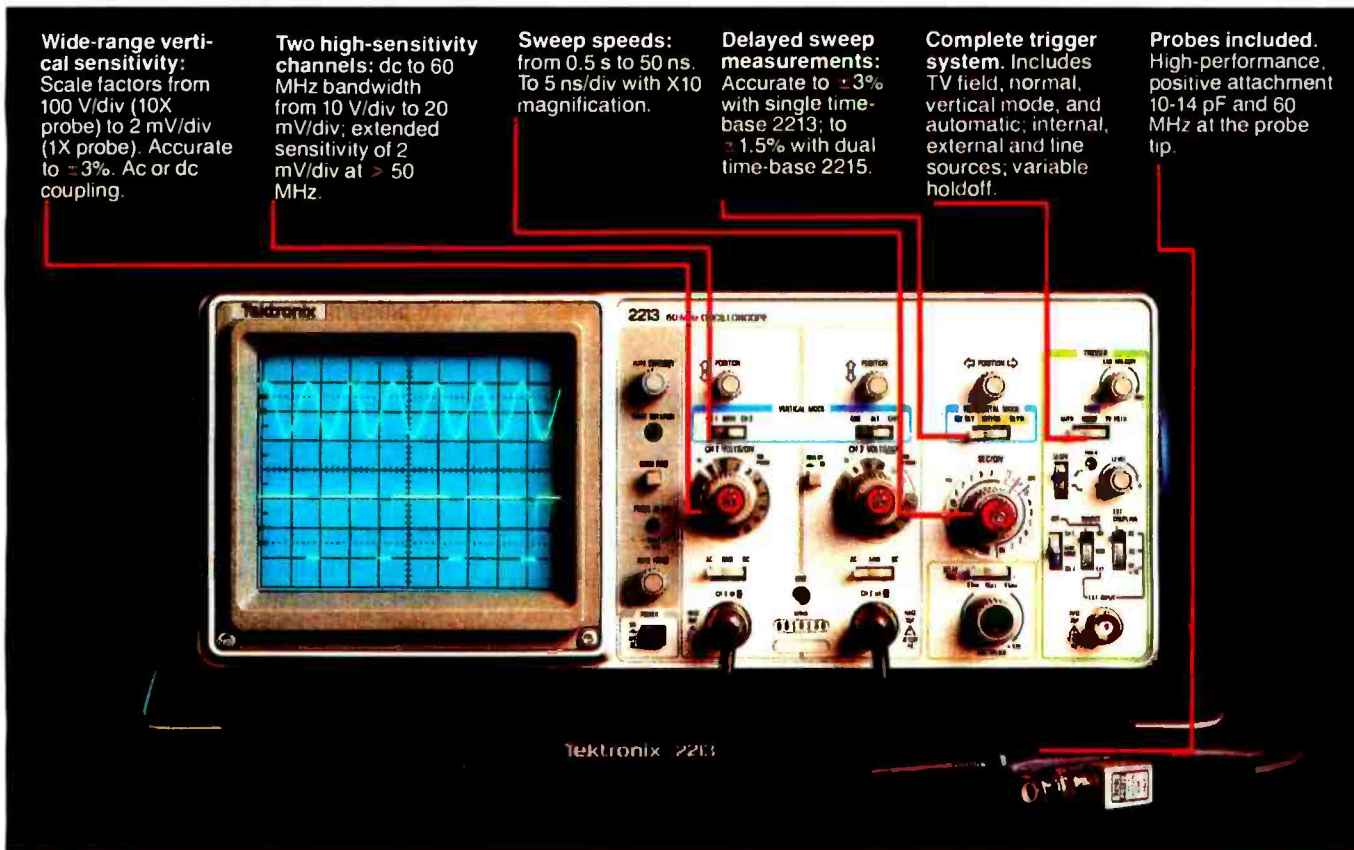

These easy to order scopes are proof that it's not expensive to have advanced, 60 MHz performance from Tektronix on your bench. It's just practical! Feature for feature, the Tek 2213 and 2215 set a price/performance standard unmatched among portable scopes. And are backed by the industry's first three-year warranty on all labor and parts, including the CRT.

So advanced they cost you less: \$1200* for the 2213! \$1450* for the dual time base 2215! These low costs are the result of a new design concept that utilizes

fewer mechanical parts than any other scope.

Yet there's no scrimping on performance and reliability. You have the bandwidth for digital and analog circuits. The sensitivity for low signal measurements. The sweep speeds for fast logic families. And delayed sweep for fast, accurate timing measurements.

Scope. Three-year warranty. Probes and expert advice. One free call gets it all!** You can order, or obtain literature, through the Tektronix National Marketing Center. Technical personnel, expert in oscil-

loscope applications, will answer your questions and can expedite delivery. Direct orders include probes, operating manuals, 15-day return policy, full Tektronix warranty and worldwide service back-up.

**Order toll-free:
1-800-426-2200
Extension 83**

In Oregon call collect:
(503) 627-9000 Ext. 83

Circle 384 on Inquiry card.

*Price F.O.B. Beaverton, OR. Price subject to change.

**Three-year warranty applies to 2000 Family oscilloscopes purchased after 1-1-83.

Feature	Computer Innovations	Digital Research	Lattice	Mark DeSmet	Mark Williams	Supersoft
Number of Passes	3	3	2	2	4	3
Source for Library	yes	no	no	no	no	yes
8080 Model	no	no	no	no	yes	yes
Small Model	yes	yes	yes	yes	yes	yes
Medium Model	no	yes	no	no	no	no
Compact Model	no	yes	yes	no	no	no
Big Model	no	yes	no	no	no	no
Initialization	yes	yes	yes	yes	yes	no
Bit Fields	yes	yes	yes	yes	yes	no
Register Variables	yes	yes	no	yes	yes	no
Floating Point	yes	yes	yes	yes	yes	no
8087 Support	yes	yes	no	yes	no	no
Overlay Manager	no	yes	yes	no	no	no
Produces Assembly	no	yes	no	yes	yes	yes
In-Line Assembly	no	no	no	yes	no	no
Assembler Format	n/a	DRI	n/a	Intel	own	DRI
Relocated Format	own	Intel	Intel	own	own	n/a

Table 2: Comparison of the features of the six compilers.

CC86, tailored for production programming, is full of features that speed up the programming process and encourage portability. For example, it includes an extensive library (27K bytes) of header source files that define commonly used structures, operating-system interfaces, and memory-allocation conventions. This promotes consistency, and thus portability, between C programs within an operating system. It also saves time because most C programmers would otherwise be required to generate their own header library.

The compiler runs four passes that may be invoked individually or all at once. Its executor program is a good example of the package's orientation toward saving development time. Only CC86 and the DRI package allow you to compile and link a program in a single command line, without resorting to a submit file. Of the two, CC86 is the simpler. All the defaults are geared toward making an

end product, in this case, executable object code. To compile and link the sieve benchmark, the user types

```
cc sieve.c
```

This will compile the program sieve.c, automatically build a loader directive file, and link an executable object file, sieve.cmd.

A wealth of options are available, including the ability to compile only (without linking), to produce an assembly source, and to use either the 8080 model (64K-byte total) or the small model (64K-byte code, 64K-byte data). Options allow control of disk-management directives and compile-time symbol definition, specification of stack, and dynamic allocation of memory-pool size. A wonderful so-called verbose option causes each pass to print out special statistics as it executes.

Assembly source files (with the extension .s) can be combined on the

Small Model:	64K-byte code 64K-byte data, stack, heap
Medium Model:	Unlimited code 64K-byte data, stack, heap
Compact Model:	64K-byte code 64K-byte data 64K-byte stack Unlimited heap
Big Model:	Unlimited code 64K-byte data 64K-byte stack Unlimited heap

Table 3: Memory allocation for the four different memory sizes allowed by Digital Research's C Compiler for CP/M-86.

command line with C source files to produce a command file. For example, the line

```
cc program1.c program2.c program3.s
```

would compile the two C source files, program1.c and program2.c, into relocatable object files, invoke the assembler to generate a relocatable object file from the assembly source file program3.s, and then link them all together into a command file. The package also includes a librarian that allows you to create a library and to add, delete, and list library objects. All this saves development time.

The linker gives you considerable control over aligning code and data segments and can be passed arguments on the command line, in a file, or interactively. The linker has far more power than even a systems programmer is ever likely to require.

Our major complaint about the CC86 compiler is that its assembler is not Intel-compatible, which means for some applications you must learn yet another assembler. Still, this is a high-quality, professional compiler with good portability, good efficiency, and excellent speed.

Digital Research C Compiler

When Digital Research speaks, programmers listen. Digital Research has begun speaking in C. DRI's C compiler has arrived, and it is a biggie. A three-pass compiler with a ton of options, a relocating assembler that creates Intel-compatible object code,

Now there's a software package that catches mistakes faster than you can make them.

WCC Software Distributing Inc.
632 Essex Street
San Francisco, CA 94105

Cliff Wilton, President
The Computer Store
855 Front Street
San Francisco, CA 94111

Dear Cliff:

Here's our report on Super SpellGuard.
In thinking how to explain the product to your
customers, there certainly is a lot to say.

First, there's the general idea that nobody's
perfect. Super SpellGuard can help them look perfect
by tracking down hard to find typos, transposed
letters and even nonexistent words.

Then there's the fact that Super SpellGuard can
proofread a 10-page report in under a minute. And the
statement that Super SpellGuard's vocabulary includes
20,000 of the most commonly used English words.

Other strengths: the original SpellGuard was named
INFOWORLD's product of the year. This is the same
basic program, only better. It also works with every
major word processing software package available
today. And has the affordable price of \$195. It
even comes from the makers of SuperCalc. If your
customers don't have word processing software, you can
always tell them about SuperWriter, which includes
Super SpellGuard.

I'm looking forward to our efforts to promote this as
a product no business should be without.

Sincerely,

Greg Karraker
Sales Manager

**Typing time
for 10-page report:
35 minutes.**

WCC Software Distributing Inc.
632 Essex Street
San Francisco, CA 94105

Cliff Wilton, President
The Computer Store
855 Front Street
San Francisco, CA 94111

Dear Cliff:

Here's a report on Super SpellGuard.
In thinking how to explain the product to your
customers, there certainly is a lot to say.

First, there's the general idea that nobody's
perfect. Super SpellGuard can help them look perfect
by tracking down hard to find typos, transposed
letters and even nonexistent words.

Then there's the fact that Super SpellGuard can
proofread a 10-page report in under a minute. And the
statement that Super SpellGuard's vocabulary includes
20,000 of the most commonly used English words.

Other strengths: the original SpellGuard was named
INFOWORLD's product of the year. This is the same
basic program, only better. It also works with every
major word processing software package available
today. And has the affordable price of \$195. It
even comes from the makers of SuperCalc. If your
customers don't have word processing software, you can
always tell them about SuperWriter, which includes
Super SpellGuard.

I'm looking forward to our efforts to promote this as
a product no business should be without.

Sincerely,

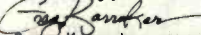
Greg Karraker
Sales Manager

**Proofreading time
with Super SpellGuard:
39 seconds.**

Super SpellGuard™

By Sorcim® 2310 Lundy Ave., San Jose, CA 95131 • (408) 942-1727

 **SORCIM®**

a linker, a big library, support for the 8087, support for large amounts of memory—this compiler has it all.

This is the only compiler tested that supports four memory models, namely, small, medium, compact, and big (see table 3). This is a significant advance in the state of the art for CP/M-compatible languages because, finally, you are allowed to write really big, RAM-resident programs in a high-level language. The different models allow you to select the way memory is allocated to the code, data, stack, and heap segments of your program (the heap is a dynamically allocated data area).

Note the assembly code produced by the identical line of C source as compiled by each of the four memory models. The assembly code in listing 6 was produced by the following line of C source code, which was compiled by the DRI compiler:

```
printf("*** WELCOME TO DIGITAL
RESEARCH C ** \n");
```

The size of the code increased by 75 percent going from the small model to the big model. While the 8088/

Listing 6: Assembly code generated by Digital Research's C compiler for CP/M-86. The difference in code among the four models is caused by setting the compiler for different memory-allocation schemes.

Small model (8 bytes)	Medium Model (10 bytes)	Compact Model (12 bytes)	Big Model (14 bytes)
mov ax,0x32 push ax call printf pop es	mov ax,0x32 push ax callf printf pop es	push ds mov ax,0x32 push ax call printf add word ptr sp,0x4	push ds mov ax,0x32 push ax callf printf add word ptr sp,0x4

8086-type processor can address a maximum of 1 megabyte of RAM (random-access read/write memory), not all machines that can run CP/M-86 can hold that much memory. The ubiquitous IBM PC, for example, cannot. On the other hand, the Compupro 816 could, theoretically at least, run an 832K-byte C program! (This would require most of a double-sided, double-density 8-inch floppy disk to hold the object code alone.)

A count of clock cycles required for each routine reveals that the code would run about 36 percent more slowly on the big model than on the small (42 clock cycles versus 57). This is what people mean when they say

that the peculiar architecture of the 8088/8086 family makes it awkward to take advantage of its 1-megabyte address space. Fortunately, the 8088/8086 family from Intel keeps getting faster (especially the 80286), so this sacrifice of execution speed could be quite tolerable.

Our first benchmark can be compiled and linked with the following command line:

```
drc sieve -asieve
```

Twenty-three options and eight sub-options (i.e., options to the options) are available when running the compiler. You are allowed to specify the memory model desired, use the 8087

At a Glance

Name	Mark Williams CC86 C Compiler version 1.1.2	Digital Research C Compiler version 1.0 (beta version)	Computer Innovations C86 version 1.33
Type	C programming language compiler	C programming language compiler	C programming language compiler
Distributor	Control-C Software Inc. 6441 SW Canyon Court Portland, OR 97221 (503) 292-8842	Digital Research Inc. POB 579 160 Central Ave. Pacific Grove, CA 93950 (408) 646-6230	Computer Innovations Inc. 10 Mechanic St., Suite J Redbank, NJ 07701 (201) 530-0995
Price	\$500 for compiler, librarian, and linker	\$600 for compiler, librarian, and linker	\$385 for compiler, librarian, and linker
Format	5¼-inch or 8-inch CP/M-compatible floppy disks	5¼-inch or 8-inch CP/M-compatible floppy disks	5¼-inch or 8-inch CP/M-compatible floppy disks
Type of Compiler	Produces object code in its own relocatable format	Produces assembly or object code in DRI relocatable format	Produces relocatable object code
Computer Needed	Any computer capable of running CP/M-86, MP/M-86, or Concurrent CP/M-86	Any computer capable of running CP/M-86, MP/M-86, or Concurrent CP/M-86	Any computer capable of running CP/M-86, MP/M-86, or Concurrent CP/M-86
Documentation	59-page loose-leaf manual in three-ring binder	167-page manual	12-page loose-leaf manual in three-ring binder
Audience	Systems and applications software developers, C programmers	Systems and applications software developers, C programmers	Systems and applications software developers, C programmers

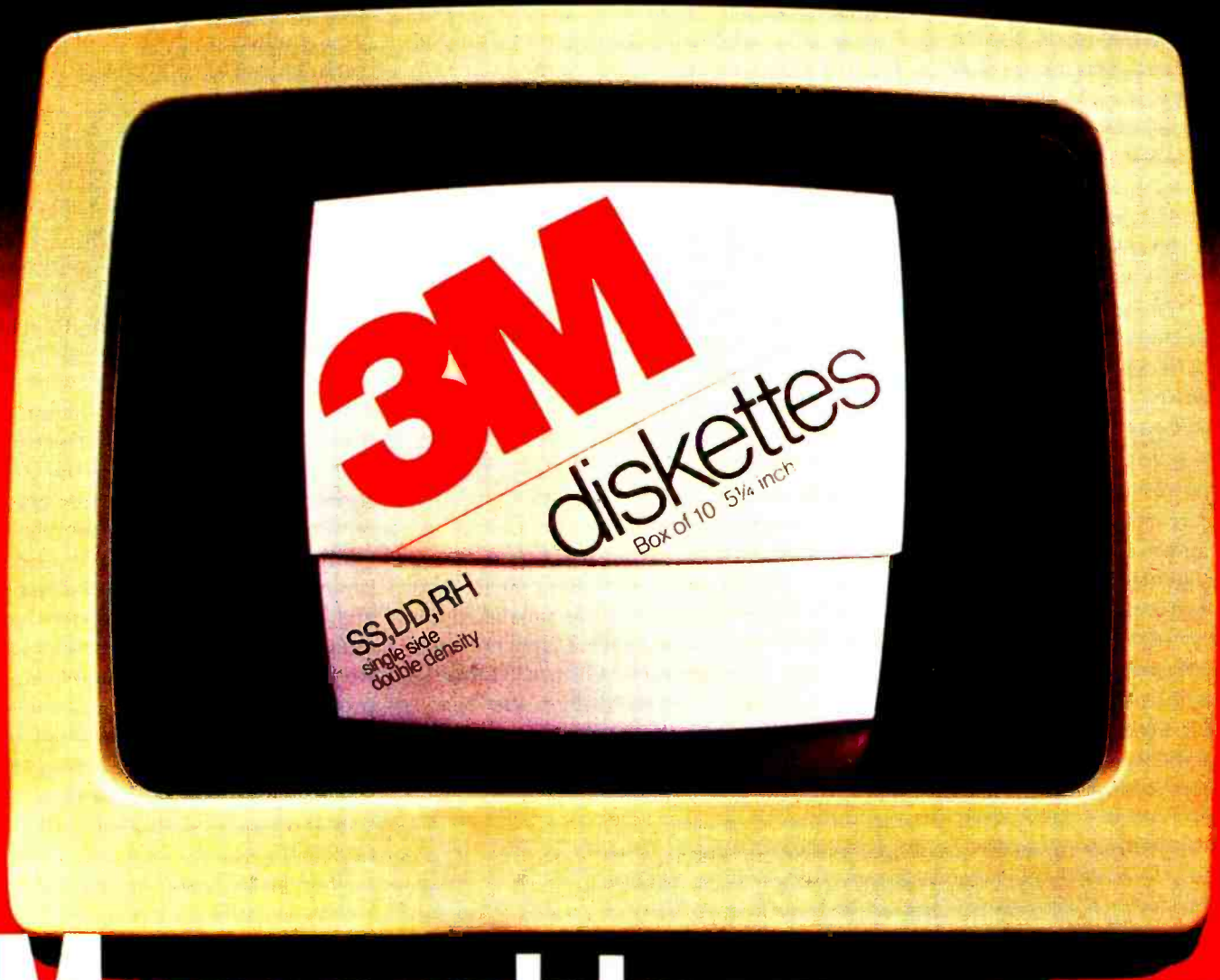

Memorable.

With 3M diskettes, your computer never forgets.

3M diskettes remember everything, every time. Because at 3M, reliability is built into every diskette. We've been in the computer media business for over 30 years. And we've never settled in. We're constantly improving and perfecting our product line, from computer tape and data cartridges to floppy disks.

3M diskettes are made at 3M. That way, we have complete control over the entire manufacturing process. And you can have complete confidence in the reliability of every 3M diskette you buy.

Look in the Yellow Pages under Computer Supplies and Parts for the 3M distributor nearest you. In Canada, write 3M Canada, Inc., London, Ontario. If it's worth remembering, it's worth 3M diskettes.



Circle 390 on Inquiry card.

3M hears you...

3M

math coprocessor, generate or suppress source and assembly listings, invoke the linker, direct disk I/O, and more and more.

DRI has obviously made an effort to give its compiler Unix compatibility. The library contains functions that have no place in a CP/M environment other than to tolerate C code transported from Unix. For example, the functions `chmod` and `chown`, which under Unix change the protection mode and owner ID of a file, are treated under CP/M as no-op instructions. This concern about portability is a very heartening sign.

Because this is the compiler DRI uses, it would be a force to reckon with regardless of its intrinsic merits. Fortunately for the industry, the compiler is not only serviceable but is a dramatic software breakthrough. It has broken through the memory barrier that has caused every previous CP/M-compatible, 16-bit, high-level language to flounder. At last we have justification for going to 16 bits, namely, space. The new frontier. Scotty, start writing code!

Computer Innovations C86

C86 by Computer Innovations is a three-pass compiler with full Kernighan and Ritchie compatibility, a large library of Unix version 7 and special machine-dependent functions (the largest library of all the compilers tested), and support for the 8087 math coprocessor. The compiler package has its own relocatable object format and linker and includes source code for all library routines.

The sieve benchmark can be compiled and linked by entering four lines in succession:

```
cc1 sieve
cc2 sieve
cc3 sieve
cl sieve
```

C86 has proven to be a reliable production compiler. We have used it to produce a number of large commercial programs at Gifford Computer Systems; and, though the benchmarks show that C86 wins no medals for speed or compactness, the very fact that we are still in the black and

have a reasonably satisfied clientele speaks favorably for it. We may have run the other compilers through their paces, but we have given C86 the acid test.

Two important features a compiler must have in order to be commercially useful are portability and reliability. Neither of these qualities is very easily measured in a benchmark. Of all the compilers tested, only C86 ran all the benchmarks as they were written, following Kernighan and Ritchie specifications, which indicates a high degree of portability.

As for reliability, that is something that can be judged only over time, and so it is not really fair to the other compilers tested to stress this aspect of C86. We know C86 is reliable because we have relied on it. Unfortunately, we don't know of any reliability benchmark that reports back a bug index or a glitch quotient. All we can do is use the compiler as a professional tool and see whether or not it works. We should point out that all significant programs have bugs. The last bug disappears only when the last user stops running the program.

To a large degree, reliability comes down to support—the willingness and ability of the producer to provide timely fixes to problems as they are discovered. In the case of C86, the support given by Computer Innovations has been little short of heroic. The introduction to the C86 User's Manual states: "If you have any questions, or problems, please write or call. We really do care and will do our best to help you. We are usually available between 9 a.m. and 9 p.m. Monday through Friday, and sometimes Saturday and Sunday."

Our major complaint with C86 is that the interface to assembly language is awkward, due to the lack of a relocatable assembler. This contrasts sharply with the DeSmet compiler, which actually allows in-line assembly (a feature we love). In general, the C86 compiler is a solid product with a good track record. Support is excellent, to say the least, and improved versions have been released regularly. It's good now, and it keeps getting better.

The Serious Game Design Tool For The Serious Designer At The Price Of A Toy For The Hobbyist

The Game Cartridge
Development System
for the Atari 2600
Video Computer System™
Optional:
Atari 5200 Supersystem
Adapter Package.

Now Available
For The
Colecovision™

The FROB-26™

Features Include:

Real-time development
No machine modification
Apple II - 48K/ one disk
drive required.

Now Only \$495
Call today to order
408-429-1551
All major credit
cards accepted.

For high profit rewards, purchase
the tool that can do the job at an
unbeatable price.

frobco

A Division of Tri-comp Polytechnical, Inc.
PO. Box 8378, Santa Cruz, CA 95061
408-429-1551

The Miracle of Creation Can Be Yours™

Atari and Apple are
registered trade-
marks of Atari, Inc.
and Apple
Computer, Inc.
respectively.
Video Computer
System is a trade-
mark of Atari, Inc.



**NEW
5 YEAR WARRANTY**

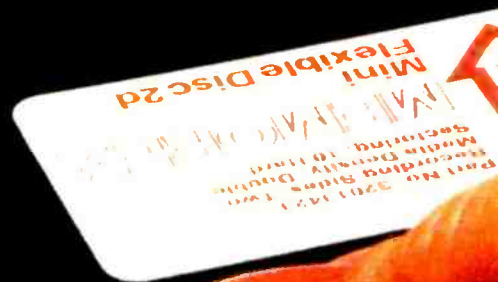

Memorex® Reliability. Now You Can Trust It Even Longer... For Years.



MEMOREX

A Burroughs Company

© 1983 Memorex Corporation. Memorex is a registered trademark of Memorex Corporation.

Memorex's new 5 year warranty on our flexible discs gives you more protection and value—at no extra cost. It's what you've come to expect from the leader of computer media products for the past 22 years.

Memorex's "Is It Live or Is It Memorex?" means quality. Quality that makes Memorex the first choice of millions of computer

customers. Quality that keeps Memorex discs working flawlessly on personal and business computers—like Atari, Apple, Commodore, IBM, Osborne, Radio Shack (TRS-80) and most others.

Your computer data is critically important to you—and to us. Use the flexible disc you can trust longer. Use Memorex. See your dealer or distributor today. Or call (800) 538-8200 for the one near you.

At a Glance

Name	Mark DeSmet C Development Package version 1.5	Lattice 8086/8088 C Compiler version 1.03	Supersoft C Compiler version 1.1.5
Type of Software Package	C programming language compiler	C programming language compiler	C programming language compiler
Distributor	C Ware 1607 New Brunswick Ave. Sunnyvale, CA 94087 (408) 736-6905	Lifeboat Associates 1651 Third Ave. New York, NY 10028 (212) 860-0300	Supersoft POB 1628 Champaign, IL 61820 (217) 359-2112
Price	\$100 for compiler, assembler, linker, and visual editor	\$500 for compiler, librarian, and linker; \$395 for linker with overlay manager	\$250 for compiler; assembler and linker/loader not included
Format	5¼-inch or 8-inch CP/M-compatible floppy disks	5¼-inch or 8-inch CP/M-compatible floppy disks	5¼-inch or 8-inch CP/M-compatible floppy disks
Type of Compiler	Produces Intel-compatible relocatable object code	Produces Intel-compatible relocatable object code	Produces DRI-compatible assembly language
Computer Needed	Any computer capable of running CP/M-86, MP/M-86, or Concurrent CP/M-86	Any computer capable of running CP/M-86, MP/M-86, or Concurrent CP/M-86	Any computer capable of running CP/M-86, MP/M-86, or Concurrent CP/M-86
Documentation	106-page manual with snap-on binding	175-page, stapled manual punched with three holes	81-page loose-leaf manual in three-ring binder
Audience	Systems and applications software developers, C programmers	Systems and applications software developers, C programmers	Students interested in learning about assembly source libraries for C

Mark DeSmet C88

The C88 compiler by Mark DeSmet offers a stunning amount of bang for the buck: the \$100 C88 development package is loaded with excellent features. The compiler conforms almost fully to Kernighan and Ritchie and has support for the 8087 math processor. An additional feature that is a great convenience for system programmers is support for in-line assembly-language code, using the #asm control. Also included is an Intel-compatible assembler, a fast linker, and a rudimentary librarian. And that same \$100 also gets you a screen editor called SEE with a cursor-control library.

This compiler does not have the maturity and finesse of the Mark Williams C, but it is useful, it compiles faster than any of the others (probably because it has only two passes), the code it produces is fast and compact, and the package is very inexpensive. It is an ideal introduction to C programming if you want to get the feel of a real, full-feature C compiler but don't want to have to choose between C and a trip to Europe. If you're toying with the idea

of taking up C, this is the way to go.

C88 does have some drawbacks: being a two-pass compiler, C88 cannot resolve references to structures and data types unless they have been previously initialized. Some high-level I/O functions such as fread, fwrite, and fseek are not included. Also, the librarian is primitive (it doesn't let you delete routines, only add them). These are by no means fatal flaws. We have completed some major production work using C88 and have been delighted with the extent to which its fast compilations speed up development time.

The sieve benchmark can be compiled by typing

```
C88 sieve
```

An executable object file is created by typing:

```
BIND sieve
```

Using a submit file on a memory drive, the sieve program was compiled, linked, and run in 10 seconds!

This compiler's price tag of \$100 is startling and may, unfortunately, hurt

its sales. It might be difficult to convince dealers to carry this compiler because the profit on a \$100 sale barely pays for one invoice and one support call. Also, a low price is often associated with poor credibility. We are not recommending that C Ware raise its price, we are recommending that people buy the compiler—look at the benchmark results. The Mark DeSmet C compiler consistently took second place, except when it took first.

Lattice 8086/8088 C Compiler

The Lattice compiler may be the one for you if you need code that really flies. Using the Olympic scoring system, Lattice was the overall winner in our benchmark speed trials (three golds, a silver, and a bronze). The powerful two-pass Lattice compiler supports full Kernighan and Ritchie (with the exception of register variables as of now) and produces Intel-compatible relocatable object code. This code can then be linked using Plink86, a remarkably versatile linkage editor from Phoenix Software Associates.

Plot your next meeting yourself.

Read how 2 pens can become your best presentation tools.

Introducing the New Personal Computer Plotter from Hewlett-Packard.

Now you can use your personal computer to generate your own presentation charts, graphs, and pie charts. How? Simply add on the new high quality, low cost HP 7470A Personal Computer Plotter.

The 7470A helps you save time and save money, and lets you communicate quickly, accurately and *effectively*.

Quicker understanding.

Data, when visualized graphically, becomes information fast. Charts and bar graphs can make any presentation clearer and more readily understood. But asking your staff to produce the graphics manually for your next presentation doesn't ensure accuracy or artistic talent. And going to outside graphics suppliers can be costly. Combined with your personal computer, the new HP 7470A plotter does the communicating for you. *Quickly. Logically.* And with off-the-shelf software available from most HP dealers.



Fast and pretty.

The 7470A gives you high plotting speed with excellent line quality...faster than any competitive small plotter. On top of all that, it comes in an attractive design package that looks nice on your desk. And it does it for only \$1,575. (U.S.A. domestic suggested retail price.)

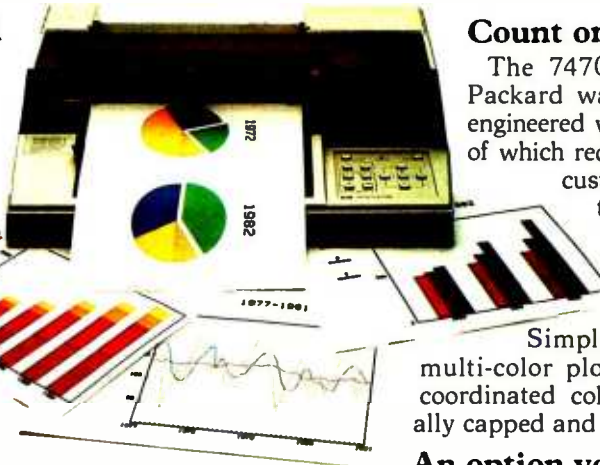

Count on it.

The 7470A is built the Hewlett-Packard way. To last. Designed and engineered with only a few parts, none of which require adjustment. And with customized integrated circuits that ensure reliability.

Pen pals.

The HP 7470A has two single-pen stables. Simple pen changes give you multi-color plots in your choice of ten coordinated colors. Pens are automatically capped and stored.

An option you'll want, too.

For only \$95, you can also get a 17057 Overhead Transparency Kit that turns your plots into transparencies for overhead projectors. For "I need it tomorrow at 9:00 A.M.!" meetings, it's a necessity.

Start plotting your next presentation today. Clip and mail the coupon below. Now.

Mail the coupon below and we'll send you—absolutely free—a sample plot, a more detailed brochure, and a sample overhead transparency.

Then...stop in at your nearest Hewlett-Packard Dealer. See the HP 7470A in action. Once you see it demonstrated you'll find a hundred ways to make your own applause-winning presentations.

When performance must be measured by results



Seeing is believing. Send me a sample plot, an overhead transparency, and more detailed information.

Name _____ Title _____

Company _____

Address _____

City, State & Zip _____

Phone Number () _____

My computer is _____

Send to: Hewlett-Packard, 16399 W. Bernardo Drive, San Diego, CA 92127—Attn: Nancy Carter

11203 BT8

THE PURCHASING AGENT has made some changes!

What's new? • New telephone number. • New address closer to our Silicon Valley suppliers. • New corporate structure.

What's the same? We still act as your buying agent, buying micro-computers, peripherals and software for you at wholesale prices. We still can buy 6,600 different products for you—all equipment is new, with full manufacturer's warranty.

Call us for your **net** price on any product not listed.

COMPUTERS	Your Net Price	COMPUTERS	Your Net Price	PRINTERS	Your Net Price
Alpha Micro 1000VFF	\$5,060	IBM compatibles & peripherals		Anadex 9501A, 2.7K buf.	1,300
Alpha Micro 1000VWF	6,957	Corona portable	2,255	Brother, parallel, daisy	783
Alpha Micro 1042V, 128K, 32 meg.	15,433	Columbia system	2,779	C. Itoh, F-10, daisy	1,200
Altos 8000-10	5,499	Davong 5 meg. H.D.	1,249	C. Itoh 8640, par.	999
Altos 8000-12	6,599	Diablo 630 API	1,775	Daisywriter 2000 48K daisy	1,150
Altos 580-10	4,779	NEC 3550	1,920	Diablo 620, 25 cps, daisy	890
Altos 5-15D, MP/IM	2,100	Seattle	CALL	Diablo 630, daisy	2,045
Altos 5-5D, MP/IM	3,950	Morrow MicroD, MD-2	1,245	Gorilla Banana, 50 cps.	199
Compupro Godbout™		Morrow MicroD, 1.6 meg.	1,631	IDS Prism 132 all opts.	1,430
Sys. 816/A*	4,200	NEC 16 bit APC HO-3	2,999	NEC 3510	1,468
Sys. 816/A, Ram21*	4,275	NEC APC WP2 (HO-3)	5,775	NEC 7710	2,094
Sys. 816/C, Ram21*	6,733	Northstar Advantage	2,324	Okidata 92, parallel	510
Sys. 816/D*	10,321	Northstar Adv. w/15 meg.	4,649	Okidata 93 w/tractor	913
Sys. 816/68K*	6,632	Onyx	CALL	Okidata 84, parallel	1,024
*completely assembled		Pied Piper I	1,055	Qume 11/40+ w/Inf'face	1,359
M-Drive-H	1,250	Sage II	3,410	Tally 160L w/tractor	789
68K	513	Sage IV w/15 meg.	5,890	Texas Instr. T181Q basic	1,240
CPU-Z 6 Mhz	258	Sanyo 1000 w/software	1,540	Texas Instr. T1810LQ	1,789
Ram 21, 128K, 12 Mhz.	807	Seattle Gazette, h. disk	5,970	Toshiba P1350	1,673
Disk 2, hard disk contr.	586	Televideo TS-802	2,598	Transtar 130	693
Pragmatic 20 meg	2,990	Televideo TS-803	2,027		
Pragmatic 40 meg.	4,686	Televideo TS-806	5,143	OTHER PERIPHERALS	
Eagle II	1,575	Televideo TS-1602G	3,448	Amdek Color II monitor	610
Eagle 1620	2,999	Televideo TS-1602GH	5,385	Corvus 18.3 meg.	3,423
Eagle 1630	4,699	Vector 4-20	3,637	w/mirror	3,995
Eagle P.C.	2,699	Vector 4-30	4,547	Hayes Smartmodem 1200	535
IBM compatibles & peripherals		Vector 4-40	4,961	Houston Instr. DMP-42	2,321
Amdek Color III monitor	429	Victor 9000 s.s.	2,874	Morrow 20 meg. w/contr.	3,650
AST MC-0645PC	277	Zenith ZF-100-21	2,525	Qume QVT 102A term.	542
Baby Blue	525	Zenith ZF-110-22	3,099	Qume QVT 103G term.	708
		Zenith ZF-120-22	3,176	Televideo 925 term.	744

Prices subject to change without notice.

B-83-8

The Purchasing Agent Philosophy, Part 2:

- Don't delay buying a computer just because a new development has been announced and will be out soon; this condition will always exist and you will never buy a computer.



THE PURCHASING AGENT, INC.

574 Weddell Drive, Ste. 5
Sunnyvale, CA 94089

(408) 744-0646

Open Monday thru Friday, 8-5 PST

The library included with the compiler implements a large subset of the Unix version 7 C library and contains a number of useful non-Unix functions as well. Because the library does not include the buffered I/O functions fread or fwrite, we were unable to run the high-level file I/O benchmark.

Our sieve program can be compiled by entering

```
lc1 sieve
```

followed by

```
lc2 sieve
```

Linking the sieve program with Plink86 is a little trickier. You type

```
Plink86n
```

then, when the => (prompt) appears, you enter the following lines (without waiting for any intervening prompt):

```
output sieve.cmd
section code group pgroup
file c, sieve
section data max 1000h group dgroup
lib lc.lib
```

The Plink86 linker is not the simplest linker we have ever seen, but it appears to be able to do everything except write articles. One reason linking a C program with Plink86 is so complex is that unlike, say, the Mark Williams linker, Plink86 is a general-purpose product and so its defaults are not designed to make it easy to link CP/M-86-compatible C programs.

A great advantage to using the Plink86 linker is that its extended version (which costs an additional \$395 above the price of the standard compiler/linker package) has a transparent overlay manager for creating programs with more than 64K bytes of code (the most code possible without using overlays). This feature allows you to create programs that will load library routines from disk as needed during program execution. The Digital Research compiler is the

Presenting Hyperion™, the world's most powerful, portable computer developed for the busy professional.

A Star is Borne 



StarLight

Hyperion is a true portable, weighing in at only 18 pounds. It is light on the eyes with its European amber screen and styling. But heavy on performance with many standard features which are expensive necessities for other personal computers. And all for a price that's less than you'd expect.

StarBright

Hyperion is bright. Communicating with the world is easy with our integrated voice and data package. Standard is our 256K RAM memory, essential for the new generation of application programs.

Hyperion has the same processor, graphics and operating system as the IBM P.C. However, an improved keyboard ties the function keys to our screen soft keys. All this means Hyperion can run popular IBM software right off the shelf — Visi Calc†, Word Star†, Data Base II† and many, many others.

Hyperion is the rising star in personal computers. Catch a rising star today.

Standard Features

Processor	Intel 8088
Software	MS DOS Advanced Basic (Microsoft) Advanced User Interface*
Memory	256K User Ram*
Drives	5 1/4", 320K bytes, IBM compatible Virtual Ram Disk (Up to 160K)*
Display System	7" Non-glare amber Graphics — IBM PC compatible Full 80 x 25 character format Auto screen off for prolonged life
Serial Port	RS 232C* RS 423*
Parallel Port	Centronics/IBM compatible*
Other Features	Time and date clock with battery back-up* Additional video output for external monitor*

*These extras worth over \$1000.

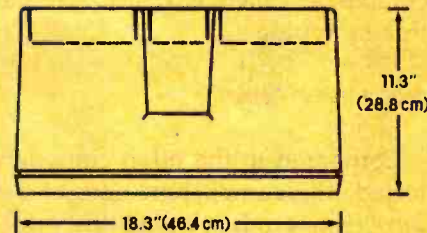

Optional Extras

Drive	Additional 5 1/4" 320K drive
Communication	IN:TOUCH telephone management system Built In 300 baud modem (103J) Direct connect
Acoustic Cups	Uses Internal modem
Expansion Chassis	5 or 10 MB of hard disk Up to 7 slots for IBM compatible cards
Carrying Case	Attractive case with accessory pockets
Multiplan†	Hyperion enhanced
123†	Hyperion enhanced
IN:SCRIBE	Word processor

†Visi Calc is a trademark of VisiCorp

†Word Star is a trademark of Micropro International Corp.

†Data Base II is a trademark of Ashton Tate

†Multiplan is a trademark of Microsoft Corp.

†123 is a trademark of Lotus Development Corp.

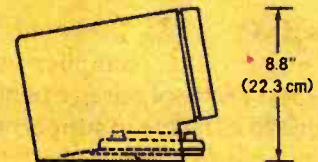

Hyperion™

the world's most powerful portable computer

The Bytec Group

North America: (613) 226-7255; Telex 053-3358

Europe: U.K. 04026 4926; Telex 894222

only other one tested that supports overlays.

Though this overlay technique generates programs that will run more slowly than the RAM-resident code supported by the Digital Research compiler, it does have the advantage of conserving memory use, which can be especially important in a multiuser MP/M-86 system. Even this sacrifice in speed can be minimized if overlays are restricted to a program's seldom-used options, in which case, overlays would allow an application program lots of convenient extras that might otherwise have been eliminated due to lack of space.

We have maintained a polite silence concerning the documentation that comes with the other compilers. With Lattice, we have to say that the documentation is superb. Only DRI even comes close.

In general, the Lattice compiler is a sophisticated, high-performance package that appears to be well suited for development of major application programs. It is unfortunate that the CP/M-86 version of Lattice was released only recently, so we have not been able to use it in production work. The benchmarks, on the other hand, speak for themselves. Lattice is a real performer. Announced improvements are a debugging facility, support for register variables and for the 8087 math coprocessor, and an additional level of optimization for speed (this should be interesting, because Lattice already seems to be the fastest).

Supersoft C

The Supersoft C compiler was unable to run three of our five benchmarks due to its failure to support the long data type. We were actually relieved that Supersoft had this failing because the process of producing executable code through the Supersoft compiler is like pulling teeth.

The great problem with the Supersoft C compiler package is that it has neither a linker nor a library-search feature. This means that to compile a program easily, you must include all library files (either on the compiler command line or with an `#include`

statement in the source file). This will ensure that all necessary library routines will be compiled with your code. It also ensures that all *unnecessary* library routines will be compiled with your code, thereby resulting in an enormous object file.

To create a smaller object file, you must cull the specific library functions required by your program from the Supersoft library source files, as well as extract the library functions called by those functions. You then use your favorite editor to patch all these together into a single file and include this new file when you compile your program.

In the two benchmarks we ran, we used the CRUNT2.C library module in toto and an editor to extract from the FORMATIO.C module the source code for `printf`. We then extracted the routines that `printf` called and included them all in a library we called `printf.c`. We compiled the sieve program with the following commands:

```
cc sieve.c crunt2.c printf.c
cod2cod sieve.cod
c2i86 sieve.u
```

This created assembly source code, which we assembled with the Digital Research assembler ASM86 using the following command:

```
asm86 sieve
```

This produced an object file of type .H86, which we fed to the CP/M-86 loader, GENCMD, to produce an executable file called SIEVE.COM. We did this by typing

```
gencmd sieve data[xfff]
```

Compared to the other compilers tested, the compilation time of the Supersoft product seems to be forever. More precisely, it is 47 times longer than the DeSmet compiler. A saving grace of the Supersoft compiler is that it gives the complete source for its library—a feature shared only by the Computer Innovations compiler.

The Elusive Ideal of Portability

Though portability is one of the

most prized characteristics of C, we were surprised at how difficult it was to find code that would run on all six of the compilers. Most surprising was that the five compilers we considered the most significant had only 14 library functions in common. This is despite the fact that some of these compilers include as many as 100 library functions. No two compilers handled direct movement of data that was bound for memory in exactly the same way, and, as might be expected, the compilers had little in common regarding the handling of functions dependent on either the processor or the operating system.

As we stated earlier, our attempts at writing a routine to test disk I/O were futile. If program portability within one operating system was a problem, transporting C programs from another operating system to CP/M promises to be especially thorny. For example, a severe incompatibility exists between CP/M and Unix. The exact length of a CP/M file is known only to within 128 bytes, whereas the length of a Unix file is known exactly (it has 1-byte "granularity"). This means that any C program written for Unix that relies on the operating system to provide the exact length of a file will be impossible to transport to a CP/M environment without a significant rewrite.

On a more upbeat note, we were startled not just by the large quantity, but the extremely high quality of C compilers already available for CP/M-86. By the time this article appears, four more compilers should be available from Aztec, Telecon, Whitesmiths, and Epsys. Sounds like C is here to stay. ■

Jerry Houston is vice-president of marketing at Gifford Computer Systems (1922 Republic Ave., San Leandro, CA 94577). He was formerly head of the technical departments at Computer Marketing Associates, Morrow Designs, and Compupro.

Jim Brodrick, who holds a doctorate in biochemistry from the University of California at Berkeley, is on the software research and development staff at Gifford Computer Systems. He has five years of experience as a C programmer and has written a C compiler for CP/M-86.

Les Kent is manager of research and development at Gifford Computer Systems. He was formerly chief production programmer at Morrow Designs and is an authority on the Unix operating system.

BASF QUALIMETRIC™ A TOTALLY NEW DIMENSION OF QUALITY.



From BASF comes a totally new level of excellence in magnetic media—the Qualimetric standard, a standard so advanced that BASF FlexyDisks® are confidently backed by an extraordinary new lifetime warranty.* The Qualimetric standard is maintained without compromise through every step of BASF design, production, inspection, and testing...reflecting an unwavering BASF commitment to media fidelity and durability. Our FlexyDisk jacket incorporates a unique two-piece liner that not only traps damaging debris away from the media surface, but also ensures precise media-to-head alignment. The result—certified 100% error-free performance, backed by BASF's exclusive lifetime warranty.*

For information security, tomorrow and beyond, look for the distinctive BASF package with the Qualimetric seal. Call 800-343-4600 for the name of your nearest supplier.

Circle 43 on inquiry card.

ENTER TOMORROW ON BASF TODAY



BASF

*Contact BASF for warranty details. © 1982, BASF Systems Corporation, Bedford, MA

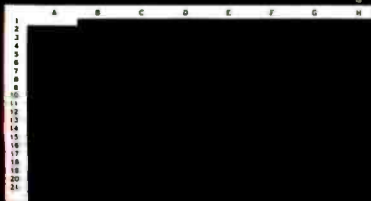
INTERACTIVE ELECTRONIC
WORKSHEET**YES**

ON-LINE REFERENCE GUIDE

NO"NAMING" OF CELLS
OR AREAS**NO**

PLAIN ENGLISH PROMPTS

NOINDIVIDUAL COLUMN
WIDTHS**NO**EXTENSIVE FORMATTING
CAPABILITIES**NO**

PROTECTED CELLS

NOMULTIPLE LINKED
WORKSHEETS**NO**

SORTING CAPABILITY

NO

VisiCalc[®] was a swell idea for then.

The next generation. First generation electronic worksheets were a good idea. They were early software management tools that could eliminate a lot of hours with a spreadsheet, calculator, pencil and eraser. Enter Multiplan, the next generation electronic worksheet that's as easy to use as it is useful.

Make comparisons. Compare Multiplan to any of the earlier electronic worksheets. We've given you some "prompts" above.

Compare learning time. Multiplan's tutorial book brings you up to speed. Fast. But Multiplan doesn't stop there. Multiplan's On-line Reference Guide gives you instant help if you have questions. It knows where you are in Multiplan and offers information related to your problem, right on the screen.

Compare ease of use. All Multiplan prompts are full length words or phrases. And Multiplan provides "naming," the ability to assign a plain English name to any

cell or area. "Gross Profit = Sales—Cost" rather than "AA44=AZ23—BK154." Which means you can work more intuitively. And faster.

Compare utility. Multiplan lets you link related worksheets so that information is transferred between them automatically. For instance, you can keep regional sales forecasts on separate sheets but link them with your overall company forecast. Then, just change the forecast for any region, and the company forecast sheet is updated automatically. Something you can't do with first generation worksheets.

Compare reports. Not just the work you can do, but the way you can present it. Multiplan's flexible formatting options allow you to produce presentation-quality reports. And its sorting capability lets you sort by either alphabetic or numeric order. So a sales manager who normally lists sales regions alphabetically could sort by amount sold and conveniently rank by sales performance. The

*Based on features in releases VC-202B0-AP2 and VC-156Y0-IBM of VisiCalc on the Apple II and IBM-PC respectively.

NOW AVAILABLE FOR THE IBM PERSONAL COMPUTER

IBMPC Worksheet

The Multiplan worksheet consists of a grid up to 80 columns wide and 255 rows high. This grid is divided into four quadrants by the horizontal and vertical center lines. The center line is always column 40 and row 128. The grid is divided into four quadrants by the horizontal and vertical center lines. The center line is always column 40 and row 128. The grid is divided into four quadrants by the horizontal and vertical center lines. The center line is always column 40 and row 128.

1	2	3	4	5
6	7	8	9	10
11	12	13	14	15
16	17	18	19	20
21	22	23	24	25
26	27	28	29	30
31	32	33	34	35
36	37	38	39	40
41	42	43	44	45
46	47	48	49	50
51	52	53	54	55
56	57	58	59	60
61	62	63	64	65
66	67	68	69	70
71	72	73	74	75
76	77	78	79	80

IBMPC Worksheet

The Multiplan worksheet consists of a grid up to 80 columns wide and 255 rows high. This grid is divided into four quadrants by the horizontal and vertical center lines. The center line is always column 40 and row 128. The grid is divided into four quadrants by the horizontal and vertical center lines. The center line is always column 40 and row 128. The grid is divided into four quadrants by the horizontal and vertical center lines. The center line is always column 40 and row 128.

1	2	3	4	5
6	7	8	9	10
11	12	13	14	15
16	17	18	19	20
21	22	23	24	25
26	27	28	29	30
31	32	33	34	35
36	37	38	39	40
41	42	43	44	45
46	47	48	49	50
51	52	53	54	55
56	57	58	59	60
61	62	63	64	65
66	67	68	69	70
71	72	73	74	75
76	77	78	79	80

IBMPC Worksheet

The Multiplan worksheet consists of a grid up to 80 columns wide and 255 rows high. This grid is divided into four quadrants by the horizontal and vertical center lines. The center line is always column 40 and row 128. The grid is divided into four quadrants by the horizontal and vertical center lines. The center line is always column 40 and row 128. The grid is divided into four quadrants by the horizontal and vertical center lines. The center line is always column 40 and row 128.

1	2	3	4	5
6	7	8	9	10
11	12	13	14	15
16	17	18	19	20
21	22	23	24	25
26	27	28	29	30
31	32	33	34	35
36	37	38	39	40
41	42	43	44	45
46	47	48	49	50
51	52	53	54	55
56	57	58	59	60
61	62	63	64	65
66	67	68	69	70
71	72	73	74	75
76	77	78	79	80

INTERACTIVE ELECTRONIC WORKSHEET **YES**

ON-LINE REFERENCE GUIDE **YES**

"NAMING" OF CELLS OR AREAS

Region 1 Profit Forecast

	Jan	Feb	Mar	Apr	May
Region 1 Sales	2000				
Region 1 Cost	1800				
Region 1 Gross Profit	200				

IBMPC Worksheet

Region 2 Profit Forecast

	Jan	Feb	Mar	Apr	May
Region 2 Sales	2000	2500	2700	2800	
Region 2 Cost	1800	1800	1975	1950	
Region 2 Gross Profit	200	700	725	850	

IBMPC Worksheet

Region 3 Profit Forecast

	Jan	Feb	Mar	Apr	May
Region 3 Sales	12000.00	12200.00	12400.00	12600.00	
Region 3 Cost	1000.00	1000.00	1000.00	1000.00	
Region 3 Gross Profit	11000.00	11200.00	11400.00	11600.00	
Growth Rate	10.0%				
Load Factor	75.0%				

IBMPC Worksheet

PLAIN ENGLISH PROMPTS **YES**

INDIVIDUAL COLUMN WIDTHS **YES**

EXTENSIVE FORMATTING CAPABILITIES **YES**

Region 4 Profit Forecast

	Jan	Feb	Mar	Apr	May
Region 4 Sales	12000.00	12200.00	12400.00	12600.00	
Region 4 Cost	1000.00	1000.00	1000.00	1000.00	
Region 4 Gross Profit	11000.00	11200.00	11400.00	11600.00	
Growth Rate	10.0%				
Load Factor	75.0%				

IBMPC Worksheet

The Company Year Forecast

	Jan	Feb	Mar	Apr	May
Region 1 Sales	2000.00	2500.00	2700.00	2800.00	
Region 2 Sales	18000.00	18000.00	18000.00	18000.00	
Region 3 Sales	10000.00				
Total Company Sales	20000.00	23000.00	24700.00	25800.00	

IBMPC Worksheet

The Company Year Forecast

	Jan	Feb	Mar	Apr	May
Region 1 Sales	10000.00	10000.00	10000.00	10000.00	
Region 2 Sales	12000.00	12200.00	12400.00	12600.00	
Region 3 Sales	2000.00				
Total Company Sales	24000.00	22200.00	22400.00	22600.00	

IBMPC Worksheet

PROTECTED CELLS **YES**

MULTIPLE, LINKED WORKSHEETS **YES**

SORTING CAPABILITY **YES**

Multiplan™ is a great idea for now.

result is a more meaningful and useful presentation of data. **Compare availability.** With Multiplan, you're not limited to a single range of computers. Multiplan is available for Apple® and for microcomputers that run MS™-DOS, XENIX™ or CP/M-80® operating systems. Multiplan supports both 40- and 80- columns on the Apple II.

Compare the source. Microsoft was the world's first microcomputer software company. Today, Microsoft software is running in well over a million installations, worldwide. Languages. Utilities. Business programs. All, maintained at the state-of-the-art.

Compare for yourself. Drop into your computer store. Compare Multiplan's powerful, user-oriented features to any electronic worksheet on the market. If you've been using VisiCalc, Multiplan's ability to directly utilize your VisiCalc files lets you easily upgrade to Multiplan. And that's just another of the many features designed

to make Multiplan the electronic worksheet for now. And years from now.

BETTER TOOLS FOR MICROCOMPUTERS

MICROSOFT

Microsoft is a registered trademark, and Multiplan, XENIX, and MS are trademarks of Microsoft Corporation. For product or dealer information, call: **DEPARTMENT NO. 31 1-800-547-3000.** In Oregon, call collect: 503-244-5500.



Five C Compilers for CP/M-80

Find out which is fastest, which is standard, and which is easiest to use

by Christopher O. Kern

Choosing a C compiler is not a trivial task. That is clear to me after spending several weeks comparing C compilers for 8080-family microcomputers running under the CP/M-80

operating system. I found that there is considerable variation in the time required to compile programs, the speed with which compiled programs run, and the size of the ex-

ecutable machine code that is produced. The compilers I tested were Aztec C version 1.05G, BDS C version 1.5, C/80 C version 2.0, Telecon C version 2.7, and Whitesmiths C version 2.1 (see "At a Glance"). I have summarized the features of these compiler packages in table 1, and I'll discuss my impressions of them individually in this article.

About C

The C programming language is a natural for 8-bit computers. C is considerably more powerful than assembler but still permits access to most of the host computer's basic machine operations. It is simple enough to be completely implemented for a computer with a limited instruction set and a relatively small main memory. It is potentially quite portable because it interfaces to the host computer through a standard input-output (I/O) library. And it's easy for amateurs like me to learn.

The Test Programs

I decided at the outset that there were at least four major tests I wanted to perform on each compiler. The first test was for efficiency in accessing

	Aztec	BDS	C/80	Telecon	Whitesmiths
Kernighan and Ritchie complete	x				[6]
Kernighan and Ritchie standard library	x				
source for library	x	x	x	x	
source for run-time routines	x	x	x	x	
separately linkable modules	x	x	[4]		x
preprocessor arguments	x	x		x	x
intermediate assembler file	x		x	x	x
in-line assembly language	x		x	[5]	
I/O redirection	x	[2]	x	x	x
library manager	x	x			x
debugging aids		x	x		
floating-point arithmetic	x	[3]			x
M80-compatible code	[2]		[2]		
requires CP/M 2.0		x			
system size required (kilobytes)	56	40	48	48	60
disk space required (kilobytes) [1]	134	55	58	81	260
size of manual (pages)	86	185	35	16	>300 [7]
list price	\$199	150	49.95	200	700

[1] Minimum for compiling and linking a program
 [2] Optional
 [3] No native floating point; supplies library functions to provide long and floating-point arithmetic
 [4] With Microsoft M80/L80 relocating macroassembler (not supplied)
 [5] Assembly-language source files can be combined with C source files at compile time
 [6] Follows Unix version 6 rather than version 7 compiler
 [7] Includes manual pages for several operating systems

Table 1: Summary of the features of the C compilers.

The CONCEPT AVT

Because VT100 users deserve more than just VT100 compatibility.



THE CONCEPT DISPLAY TERMINAL

VT100 compatibility is one thing, but eight pages of memory, programmable function keys, windowing, multiple computer capabilities, ANSI standard conformance...and VT100 compatibility is something else. Only from Human Designed Systems.

A good news/great news story from Human Designed Systems.

First the good news. The *concept* AVT display terminal gives you everything you need in an 80/132-column ANSI/VT100-compatible display terminal. And at a very competitive price.

Now the great news. The *concept* AVT display terminal provides an exciting, new set of capabilities that lets you do much more. Without changing the price.

It starts with ANSI standard conformance, DEC software compatibility, and 80/132-column capability, and extends that even further by offering eight pages of display memory to relieve the interactive user of the need to generate unnecessary hardcopy printouts and to provide the application developer with a powerful tool for applications requiring multiple formats and storage of large volumes of text; by enabling users to permanently configure a terminal for their needs or applications; by providing functionality

\$1295*

designed to improve the effectiveness of slow-speed applications; by enabling users to create true windows within display memory; by providing programmable function keys which transmit data and/or execute terminal commands; by providing up to three additional communications ports for connection to other peripherals and computers; by providing flexible user networking functionality for use in a wide range of different applications, including multiple computer connections; and by doing much more.

VT100 compatibility and ANSI standard conformance. Add it to the *concept* display terminal's 132-column performance, in ASCII or APL/ASCII models, with multiple computer capabilities, windowing, programmable function keys, multiple pages of memory, and much more, and you can see why Human Designed Systems has given terminals a new meaning...and that means true economy.

human designed systems, inc.

3440 Market Street, Philadelphia, PA 19104
215-382-5000 Circle 195 on Inquiry card.

*Quantity one. DEC and VT are trademarks of Digital Equipment Corporation.

Human Designed Systems. We're redefining terminal performance.

Atlanta — (404) 391-9763; Boston — (617) 329-3510; Chicago — (312) 825-2960; Dallas — (214) 437-1888; Delaware — Infocon: (302) 239-2942; Hawaii — Gray Associates: (808) 261-3751; Los Angeles — (213) 410-9454; Northern New Jersey — Infocon: (201) 624-1372; New York City Area — Infocon: (212) 689-8833; New York State — Naco Electronics: Rochester: (716) 223-4490; Syracuse: (315) 699-2651; San Francisco — (415) 692-4184; Washington, DC — International Systems Marketing: (301) 279-5775; Australia — I. O. Peripherals Pty. Limited: (02) 427 3555; Belgium — BELCOMP: 091/25 22 88; Canada — CAIL Systems: Toronto: (416) 362-1063; Denmark — ADCOM Data Aps: 1-19 44 66; Finland — Modulsystem OY: 0-6926511; France — Walton: (1) 226.06.90; Singapore — DTS Singapore: (65) 33-88-566; Sweden — Allnovo Data AB: 08-37 25 15; Switzerland — Mitek ag: 02/461 22 52; United Kingdom — Shandell Systems Ltd.: 02407-2027; West Germany — COMKO Computersystemges, mbH: 0221-48 30 51.

DISTRIBUTORSHIP INQUIRIES INVITED.

www.americanradiohistory.com

automatic variables, which come into existence only when a particular function is entered. As soon as the function is exited, the variables are discarded. In other words, automatic variables exist while the function they belong to is actually executing. They are a problem on an 8-bit computer because of its shortage of registers and its limited addressing modes.

A good choice for this test was the Sieve of Eratosthenes program for generating prime numbers that Jim and Gary Gilbreath used in their article "Eratosthenes Revisited: Once More Through the Sieve" (see the January 1983 BYTE, page 283). It has quite a few variables, which are constantly being juggled among machine registers so that arithmetic and logical operations can be performed on them (see listing 1). To make the test as pure as possible would require moving the array of flags into the function proper, i.e., making the array an automatic variable instead of an external one.

The second test I wanted to perform was to measure the efficiency of each compiler in coding function (procedure) calls. Because good C style encourages the use of many small functions instead of a few large ones, I wanted to see how much overhead was associated with entering and leaving a function.

To do that, I wrote a program to compute a Fibonacci series recursively. The Fibonacci function, $F(x)$, is defined as:

$$F(x) = 1 \quad \text{for } x \leq 2$$

$$F(x) = F(x-1) + F(x-2) \quad \text{for } x > 2$$

(see listing 2). Because only one variable is involved and relatively little processing is performed on it, the Fibonacci program is a good test of function overhead.

Many C programs read or write a file one character at a time. Because most operating systems won't let you do that, at least not efficiently, the standard library supplied with each

of the C compilers includes several functions to perform buffered I/O (input/output).

Here is how it works: a file is read into a buffer in relatively large chunks. Then it is parceled out to the program byte by byte. In writing to a file, the process is reversed: the file is assembled in the buffer 1 byte at a time. When the buffer becomes full, it is "flushed"—written out to the disk in a single, relatively efficient operation.

My third test program simply copies its input to its output (see listing 3a). I knew that the results of this test would in large part reflect the size of the buffers used by each compiler. As a rule, the larger the buffer, the faster the program would run; but the results indicate that other factors are at work as well.

Finally, I wanted to see how each compiler package performed in handling strings. Strings in C are just arrays of characters, delimited by a single null or zero byte. Internally, each character is represented by an offset to a pointer variable. The variable points to the starting address of the string in the computer's memory.

Pointers are used quite a bit in C programming, much as they are in assembly programming, and in sharp contrast to languages like BASIC and Pascal, which can operate on strings directly. In C, several crucial library functions perform basic operations on strings, such as measuring or comparing them.

I used a program to sort lines of text alphabetically to test each compiler's string-handling ability. The only problem was how to read the test data into the program. To eliminate any variation among the packages in performing file I/O, I decided to have the program take its input from the console (see listing 4 on page 121).

But instead of typing in the lines by hand—which obviously would have injected an uncontrollable variable into the test procedure—I read them from a file using Microshell. Microshell is a replacement CP/M-80 command interpreter that allows the "redirection" of console input. In effect, the program thinks it is getting its input from the console when in fact it

Listing 1: *The prototype of the primes program, which was written in the version of C described by Kernighan and Ritchie; it generates primes using the Sieve of Eratosthenes method. The program's purpose is to test the compiler's efficiency in using automatic variables. This is the basic version of the program that was tried on all the compilers; some modifications were necessary to get it to run on each one.*

```
A>
A>type sieve1.c
SIEVE1.C?

A>type b:sieve1.c
#include "stdio.h"

#define SIZE      8190  /* size of number Array */
#define FALSE     0
#define TRUE      1

char   flag[SIZE + 1];

main()   /* compute primes using sieve of Eratosthenes */
{
    int   i, j, k, count, prime;

    printf("10 iterations: ");

    for (i = 1; i <= NTIMES; i++) {
        count = 0;
        for (j = 0; j <= SIZE; j++)
            flag[j] = TRUE;
        for (j = 0; j <= SIZE; j++) {
            if (flag[j] == TRUE) {
                prime = j + j + 3;
                for (k = j + prime; k <= SIZE; k += prime)
                    flag[k] = FALSE; /* discard multiples*/
                count++;
            }
        }
    }

    printf("%d primes.\n", count);
    exit(0);
}
```

cdex™ Training Programs Make Using Personal Computers Easy.



Even the best application programs and personal computers still take a considerable amount of time to learn how to use. That is . . . until now!

Cdex Training Programs are computer-assisted training programs that make learning straight-forward and efficient. In an hour, you can master the material on the Cdex disks and begin using the intended product.

It's tough to learn about computers from a book. That's why all Cdex Training Programs are on disk and are:

- Highly Interactive . . .**
Creating a dialogue with you and serving as your personal tutor.
- Completely Self-paced . . .**
You set your own learning time.
- Graphically Oriented . . .**
Remember, a picture is worth a thousand words.

Usable Now and Later . . .
Clear and concise training and reference programs for the first-time or experienced user.

Cdex Training Programs run on the IBM® PC and XT Computers, COMPAQ® Portable Computer, Apple® IIe, II Plus and III Computers, DEC Rainbow® 100 Computer and Texas Instruments Professional Computer. See how effective a Cdex Training Program can be; ask your computer dealer for a demonstration.

Cdex™ Training Programs are available for:

- The VisiCalc® Program
- The WordStar™ Program
- The SuperCalc™/SuperCalc™™ Programs
- The EasyWriter II™ Program
- How to Use Your IBM® Personal Computer with CP/M-86® and Concurrent CP/M-86™
- How to Use Your IBM® Personal Computer with PC DOS
- How to Use Your Apple® IIe Personal Computer
- How to Use Your Texas Instruments Professional Computer
- Managing Your Business with the Lotus™ 1-2-3 Program
- Managing Your Business with the MULTIPLAN™ Program
- Managing Your Business with the VisiCalc® or VisiCalc® Advanced Version Program
- Managing Your Business with the SuperCalc™ or SuperCalc™™ Program
- The dBASE II® Program
- IBM® PC DOS 2.0
- DB Master™ - Version 4
- The BPI® General Accounting Program

Cdex™ Training Programs We make it easy.

cdex™
Cdex Corporation
5050 El Camino Real
Los Altos, CA 94022
415 964 7600

is getting it from a file. (See my review, "Microshell and Unica: Unix-style Enhancements for CP/M," December 1982 BYTE, page 206.) Because Microshell performed the file I/O, the time required to read the data was the same in all the tests.

All the prototype test programs were written to conform to the standard set out in *The C Programming Language*, by Brian W. Kernighan and Dennis M. Ritchie (Prentice-Hall, 1978). This is the "bible" of C programming and a fine tutorial introduction to programming in general. All the compilers tested cite it. As it turned out, only one—Aztec C—really followed it.

The Method

As each compiler arrived, I tried it out on each of the prototype test programs. Usually I had to make some changes to get the programs to compile. Only the Aztec compiler accepted all the prototype code without modification.

The copy program would not work with the BDS compiler because the file I/O functions in the BDS library are nonstandard (see listing 3b). Both the copy and sort programs had to be changed before they could be compiled with C/80 because the C/80 library does not include the common string comparison and measurement functions.

The Telecon compiler surprised me. It couldn't handle the addition of two constants in the subscript of an array declaration (e.g., array[SIZE + 1]) such as that used in the primes program. And the Whitesmiths compiler until recently came with its own idiosyncratic "standard" I/O library; as a consequence, all the programs needed minor changes (see listing 3c for an example). [Editor's note: Whitesmiths has fixed this by offering an additional Unix-compatible I/O library that has all of the standard C functions. . . . B.R.]

These initial tests and conversions gave me some experience with the compilers I was not familiar with. I had used BDS C and C/80 before, but I wanted a uniform environment for the actual timing tests. I made up a set of identical floppy disks, which

Text continued on page 122

Listing 2: Prototype of the fib program, which uses recursion to compute a Fibonacci series. The recursion tests the compiler's handling of function calls.

```
#include "stdio.h"

#define NTIMES 10      /* number of times to compute Fibonacci value */
#define NUMBER 24     /* biggest one we can compute within 16 bits */

main()                /* compute Fibonacci value */
{
    int i;
    unsigned value, fib();

    printf("%d iterations: ", NTIMES);

    for (i = 1; i <= NTIMES; i++)
        value = fib(NUMBER);

    printf("fibonacci(%d) = %u.\n", NUMBER, value);
    exit(0);
}

unsigned fib(x)       /* compute Fibonacci number recursively */
int x;
{
    if (x > 2)
        return (fib(x - 1) + fib(x - 2));
    else
        return (1);
}
```

Listing 3: The copy program. This tests the compiler's buffered I/O capabilities. Listing 3a is the prototype; listing 3b and listing 3c are the BDS and Whitesmiths versions, respectively. Note that the BDS file-input and file-output functions require the programmer explicitly to look for and end a file with the CP/M-80 end-of-file character (represented by CPMEOF). In the Whitesmiths version, note the differences from the prototype in the cpmstr, fopen, fcreate, putc, and putfmt functions. The constant values in uppercase are all defined in the standard header file std.h.

(3a)

```
#include "stdio.h"

main(argc, argv)     /* copy file a byte at a time */
int argc;
char *argv[];
{
    int c;
    FILE *infile, *outfile;

    if (argc < 3)
        errexit("Usage: copy oldfile newfile", NULL);
    if (strcmp(argv[1], argv[2]) == 0)
        errexit("File names must be different", NULL);
    if ((infile = fopen(argv[1], "r")) == NULL)
        errexit("Can't open", argv[1]);
    if ((outfile = fopen(argv[2], "w")) == NULL)
        errexit("Can't create", argv[2]);

    printf("File %s ", argv[1]);

    while ((c = getc(infile)) != EOF)
        putc(c, outfile);

    fclose(infile);
    fclose(outfile);

    printf("copied to %s.\n", argv[2]);
    exit(0);
}

errexit(s1, s2)       /* print error message and die */
char *s1, *s2;
{
    printf(s2 == NULL ? "%s\n" : "%s %s\n", s1, s2);
    exit(-1);
}
```

Listing 3 continued on page 116

More than a personal computer.



It's an accountant, word processor and financial planner. Now for only \$3,390 per user.*

No matter what business or profession you're in, ALTOS® has a desktop business computer system that can improve your efficiency—at a price that won't put you out of business.

For example, a typical Altos business solution includes integrated software applications for accounting (including a self-paced, step-by-step, built-in tutorial), word processing and financial planning. They're all easy to learn and use.

You can also choose from hundreds of other applications for attorneys, dentists, doctors, insurance agents, manufacturers, pharmacists, realtors and many more.

Altos systems are designed to grow as your business grows. You can start with a single user and add more users on the same system. Plus you can link hundreds together with a network.

And when you're ready, built-in features let you add more storage capacity, peripherals and communications—even electronic mail and appointment scheduling.

All of our systems are backed by responsive, nationwide service and support through the Customer Service Division of TRW, Inc.

So if your business or profession demands more than a personal computer can deliver, talk to Altos. Call, write or clip the coupon today for a free brochure and the name of your local Altos representative.

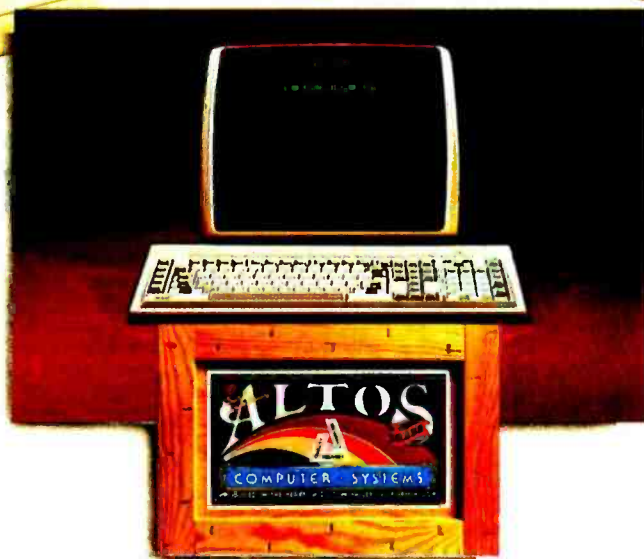

Packed with more value for business

- Please tell me more about the hundreds of uses for an Altos desktop business computer system.
- My application is _____.
- Please have an Altos representative contact me.

Name _____ Title _____

Company _____ Tel _____

Address _____

City/State/Zip _____

Mail to: Altos Computer Systems, Attn: Marketing Services,
2641 Orchard Park Way, San Jose, CA 95134

800-538-7872 (In Calif., 800-662-6265)

In Canada, (416) 864-0740.

BT-8

*Complete five user Altos system for \$3,390 per user or \$16,950. Price approximate and may vary in your area. Packaged system includes an Altos 586-10 hard disk computer with the XENIX™/UNIX™ operating system with the Altos "Business Command Menu Interface," five terminals, and the ALTOS ACCOUNTANT (with the built-in ALTOS COMPUTER TUTOR), ALTOS EXECUTIVE WORD PROCESSOR, and ALTOS EXECUTIVE FINANCIAL PLANNER applications. Price does not include printer, cables, installation, taxes, additional training and maintenance.

ALTOS is a registered trademark of Altos Computer Systems. XENIX is a trademark of Microsoft and is a microcomputer implementation of the UNIX operating system. UNIX is a trademark of Bell Laboratories. ©1983 Altos Computer Systems



This New Arrival is...



CONTROL/9000

4 USER, 10 MB **\$6195** incl. SOFTWARE

...one bundle of Joy!

CONTROL/9000... 4 users, 10,20 or 40MB, MP/M based. from **\$6195**

CONTROL/NET... up to 10 users, S-100 bus, each user has 64K & Z-80A or B. from **\$6749**

PLUS

SELECT™ word processing **\$495**

SUPERCALC™ **195** *Free!*

TABSOFT™ Accounting **4165**

\$4855



"Dealers call for information"

SuperCalc is a trademark of Sorcim, Inc. Select is a trademark of Select Information Systems, Inc. MP/M is a trademark of Digital Research Corp. Tabsoft is a trademark of ETC

707 NICOLET AVE., WINTER PARK, FL 32789
(305) 628-3850

Listing 3 continued:

(3b)

```
#include "bdscio.h"

main(argc, argv) /* copy file a byte at a time */
int argc; /* uses BDS library functions */
char *argv[];
{
    char c;
    FILE infile, outfile;

    if (argc < 3)
        errexit("Usage: copy oldfile newfile", NULL);
    if (strcmp(argv[1], argv[2]) == 0)
        errexit("File names must be different", NULL);
    if (fopen(argv[1], &infile) == ERROR)
        errexit("Can't open", argv[1]);
    if (fcreat(argv[2], &outfile) == ERROR)
        errexit("Can't create", argv[2]);

    printf("File %s ", argv[1]);

    do {
        putc(c = getc(&infile), &outfile);
    } while (c != CPMEOF);

    fclose(&infile);
    fclose(&outfile);

    printf("copied to %s.\n", argv[2]);
    exit(0);
}

errexit(s1, s2) /* print error message and die */
char *s1, *s2;
{
    printf(s2 == NULL ? "%s\n" : "%s %s\n", s1, s2);
    exit(-1);
}
```

(3c)

```
#include "std.h"

main(argc, argv) /* copy a file a byte at a time */
int argc; /* uses Whitesmiths library functions */
char *argv[];
{
    int c;
    FIO infile, outfile;

    if (argc < 3)
        errexit("Usage: copy oldfile newfile", NULL);
    if (cmpstr(argv[1], argv[2]) == YES)
        errexit("File names must be different", NULL);
    if (fopen(&infile, argv[1], READ) == NULL)
        errexit("Can't open", argv[1]);
    if (fcreate(&outfile, argv[2], BWRITE) == NULL)
        errexit("Can't create", argv[2]);

    printf("File %p ", argv[1]);

    while ((c = getc(&infile)) != EOF)
        putc(&outfile, c);

    fclose(&infile);
    fclose(&outfile);

    printf("copied to %p.\n", argv[2]);
    exit(0);
}

errexit(s1, s2) /* print error message and die */
char *s1, *s2;
{
    printf(s2 == NULL ? "%p\n" : "%p %p\n", s1, s2);
    exit(-1);
}
```

RENT SOFTWARE BEFORE YOU BUY!

from our SOFTWARE RENTAL LIBRARY

You can now RENT the most popular software available for just **20-25%*** of Manufacturers' Retail Price

- Eliminate the risk—rent first!
- 100% of rental fee applies toward purchase
- All purchases are 20% Off of Manufacturer's Suggested List
- Rentals are for 7-days (plus 3 days grace for return shipping)

SPECIAL INTRODUCTORY OFFER

There are now 2 different plans to choose from:

<p>Join the Game Group, \$25.00 per year and rent as many games as you like for only 20-25% of Mfrs. Sugg. Retail Price.*</p> <p><small>Minimum order, 3 game rentals</small></p>	<p>Join the Business Group, \$50.00 per year and rent as many business application programs as you like for only 20-25% of Mfrs. Sugg. Retail Price.*</p>
--	--

REMEMBER, THESE ARE NOT DEMOS, BUT ORIGINAL UNRESTRICTED SOFTWARE PROGRAMS

(complete with manuals in original manufacturers' packages)

To Immediately Order, or for more information:

UNITED COMPUTER CORP.
 Software Rental Library
 Culver City, California

Canadian Orders Welcome

Toll Free CALL 1-800 992-7777
 In California CALL 1-800 992-8888
 In L.A. County CALL 1-213 823-4400



*Plus postage and handling.

Xerox Service Centers. The personal computer back-up system you've been looking for.

Unfortunately, most people find out the hard way that there's one question even a personal computer can't answer.

Where can you take it for service?

We have a suggestion. Come to one of our

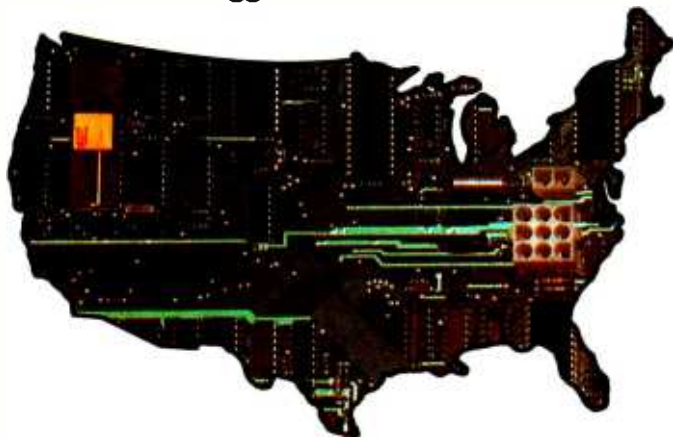

new Xerox Service Centers. We have 82 nationwide. And we're multiplying faster than software programs.

Right now we're equipped to handle Osborne™ Computers, Epson™ MX Series Printers, Pied Piper™ Computers, Morrow Designs Micro Decision™ Computers, Corona Data Systems Computers, Enter Sweet Pea™ Color Plotters, Cameo Electronics Winchester Disk Drives, Okidata Microliner™ and Pace-mark™ and Amdek™ products. In addition to a number of Xerox products like the 820 Personal Computer and Diablo™ Printers. But in the future, we'll be servicing even more brands of personal computers and related items.

Our service people have to undergo one of the toughest training programs in the industry. Including plenty of

hands-on experience and intensive study of computer technology.

Then we put them through the specialized courses on other brands.

We've even provided a back-up system to our back-up system with a nationwide "hot line" to our Xerox Technical Support Centers. So in the unlikely event your bugaboo baffles our local whiz, there's extra help close at hand.

And we keep our parts departments well stocked. Which means your problem can be fixed a lot faster than you'd imagine.

But one of the best things about bringing* your equipment to us is that you get Xerox quality service at a very affordable price.

So come in and see us. Or contact the Xerox Five Star Service Dealer in your area for more information.

Because 82 new Xerox Service Centers are not only a nice step forward for us. They're a great system for you to fall back on.

Visa, MasterCard and American Express Cards accepted.

*Pick-up and delivery available.

Xerox Service Centers.

Alabama: Birmingham, 167-A Citation Court, (205) 945-1280.
Arizona: Tempe, Suite 101, 2109 S. 48th St., (602) 967-1922.
California: Alhambra, 614 South Marengo, (213) 289-0174; Anaheim, 232 W. Cerritos Ave., (714) 776-8143; Carson, Suite E, 20630 Leapwood, (213) 516-6650; Chatsworth, 20802 Plummer St., (213) 709-0226; Sacramento, 4247 S. Market Court, (916) 920-2275; San Diego, Suite N, 7343 Ronson Rd., (619) 569-1212; San Francisco,





Suite B, 1555 Burke Ave., (415) 821-7719; *San Leandro*, 1981 Adams, (415) 635-9300; *Sunnyvale*, #6, 540 Weddell Drive, (408) 734-2540. **Colorado:** *Denver*, Suite 201, 8200 E. Pacific Place, (303) 696-8966. **Connecticut:** *Hartford*, 593 Farmington Ave., (203) 236-2381. **Delaware Area:** *Westchester, Pa.*, 301 Willowbrook Lane, (215) 431-0533. **Florida:** *Altamonte Springs*, 716 North Lake Blvd., (305) 830-8109; *Ft. Lauderdale*, #502, 1500 N.W. 62nd St., (305) 491-3202; *Jacksonville*, Unit #4, 3035 Powers Ave., (904) 731-7218; *Miami*, 6908 N.W. 72nd Ave., (305) 887-2711; *Tampa*, Suite 6, 6201 Johns Rd., (813) 886-0779. **Georgia:** *Atlanta*, Suite 10, 2215 Perimeter Park Drive, (404) 458-1016. **Hawaii:** *Honolulu*, Suite 104, 627 South St., (808) 526-0885. **Illinois:** *Chicago*, 165 N. Canal St., (312) 559-9440; *Elk Grove Village*, 2216 Landmeier Rd., (312) 437-3180; *Lombard*, 436A Eisenhower Lane, (312) 953-

1113; *Springfield*, 2036 S. MacArthur, (217) 523-1007. **Indiana:** *Indianapolis*, 5335 W. Minnesota St., (317) 241-2888.

Iowa: *Des Moines*, 700 E. 4th St., (515) 282-8700.

Kansas: *Overland Park*, 6383 W. 110 St., (913) 381-9819; *Wichita*, 7804 E. Funston, (316) 685-4731. **Kentucky:** *Louisville*, 10308 Bluegrass Parkway, (502) 499-7224. **Louisiana:** *Baton Rouge*, Suite K, 10466 Airline Highway, (504) 291-5974; *Harahan*, Suite F, 550 Wholesalers Parkway, (504) 733-1201. **Maryland:** *Hunt Valley*, 100 Lakefront Drive, (301) 667-8711; *Lanham*, 9730A-1 George Palmer Highway, (301) 459-3973; *Rockville*, 12288 H. Wilkens Ave., (301) 468-8870. **Massachusetts:** *Braintree*, 190 Forbes Rd., (617) 848-5750; *Woburn*, 248 W. Cummings Park, (617) 938-0845. **Michigan:** *Lansing*, Suite 7, 6810 South Cedar, (517) 694-3350; *Troy*, Suite 7, 1270 Rankin, (313) 583-2935. **Minnesota:** *Edina*, 3650 Hazelton Rd., (612) 920-4472. **Mississippi:** *Jackson*, 870 Foley St., (601) 948-6302. **Missouri:** *St. Louis*, 11984 Dorsett Rd., (314) 991-2106. **Nebraska:** *Omaha*, 11129 Mill Valley Rd., (402) 493-0387. **New Jersey:** *Lodi*, 300-1B Rt. 17, (201) 777-4441; *Monmouth Junction*, Bldg. 1, 248 U.S. Rt. 1, (201) 329-2050; *Whippany*, 145 Algonquin Parkway, (201) 428-1275. **New Mexico:** *Albuquerque*, Suite D, 5659 Kircher Blvd., (505) 344-3563. **New York:** *Albany*, Pine West

XEROX®, 820 and Diablo® are trademarks of XEROX CORPORATION.

Plaza One, Washington Ave Ext., (518) 869-9082; *Cheektowaga*, 198 Sugg Rd., (716) 634-2993; *Elmsford*, 5 Westchester Plaza, (914) 592-4454; *Lake Success*, Suite 1-E8, 3000 Marcus Ave., (516) 437-1134; *Liverpool*, 7150 Henry Clay Blvd., (315) 451-7420; *New York*, 405 Lexington Ave., (212) 697-2190; *Rochester*, 333 Metro Park, (716) 424-4010. **North Carolina:** *Charlotte*, 2838 G Interstate 85 S., Carolina Center, (704) 399-1523; *Raleigh*, 5225 North Blvd., #1 N. Commerce Center, (919) 876-1610. **Ohio:** *Akron*, 2650 S. Arlington Rd., (216) 644-3251; *Cincinnati*, 4814 Interstate Drive, (513) 874-0884; *Cleveland*, Technology Plaza, 5267 E. 98th St., (216) 587-1546; *Columbus*, 3711 Corporate Drive, (614) 895-3033. **Oklahoma:** *Oklahoma City*, 2122 South Meridian, (405) 682-5030; *Tulsa*, 4725A South Memorial Drive, (918) 665-0811. **Oregon:** *Tigard*, 10110 S.W. Nimbus Ave., B-9, (503) 684-1152. **Pennsylvania:** *Harrisburg*, 806 S. 29th St., (717) 564-2602; *King of Prussia*, Suite C, 1006 W. 8th Ave., (215) 337-4486; *Philadelphia*, Suite H&I, 9140 Academy Rd., (215) 331-0999; *Pittsburgh*, 601 Holiday Drive, (412) 921-8202. **Tennessee:** *Memphis*, Suite 143, 1835 Nonconah Blvd., (901) 346-2211; *Nashville*, 1854 Airline Drive, (615) 883-5102. **Texas:** *Austin*, #112, 7950 Anderson Square, (512) 451-6263; *Dallas*, Suite 104, 1625 W. Mockingbird Lane, (214) 630-6647; *Fort Worth*, 3273 Crabtree St., (817) 626-8243; *Houston*, Suite 220, 7280 Wynnwood, (713) 862-1784; *Houston*, 3642 Westchase Drive, (713) 789-3070; *San Antonio*, Suite 112, 2411 Northeast Loop 410, (512) 655-0085. **Utah:** *Salt Lake City*, 3697 W. 1987 S., (801) 973-7316. **Virginia:** *Fairfax*, 2731B Prosperity Ave., (703) 698-7477; *Richmond*, 8707 W. Broad St., (804) 747-0275; *Virginia Beach*, 1448 Air Rail Ave., (804) 464-4752. **Washington:** *Renton*, 266 S.W. 43rd St., (206) 251-9155. **West Virginia:** *Charleston*, 523 Central Ave., (304) 342-8015. **Wisconsin:** *New Berlin*, 2995 South Moreland, (414) 784-3690.

Circle 429 on Inquiry card.

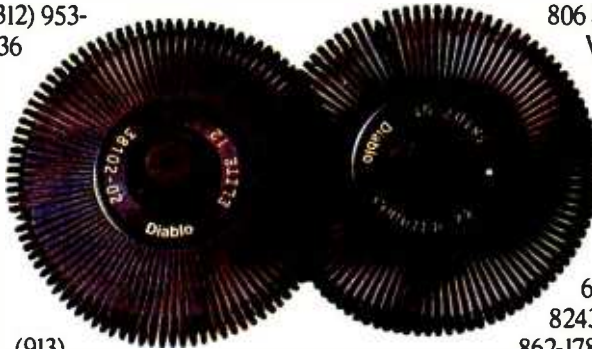

Hank: Here's the report you've been waiting for. Hope you put your system on automatic and didn't wait up.

To all reps: Price changes on following items effective immediately: No. 10-111A, 10-114A; 10-AL.

Take that, bud. (And retaliate fast. I know phone rates are low now, but game's cutting into sack time.)

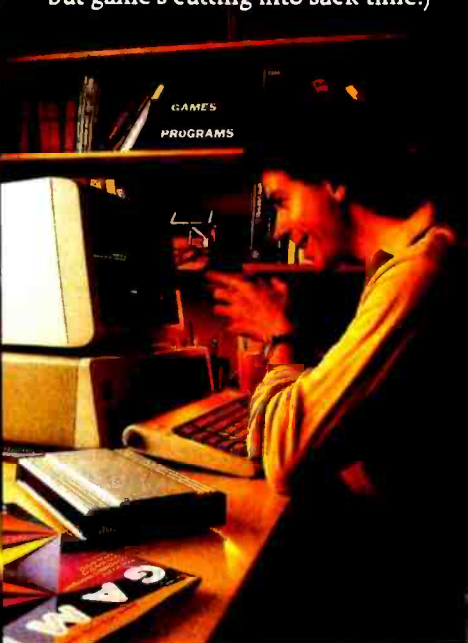
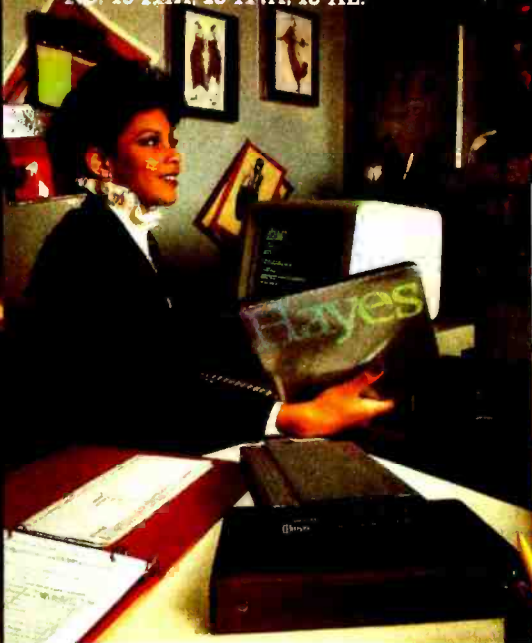
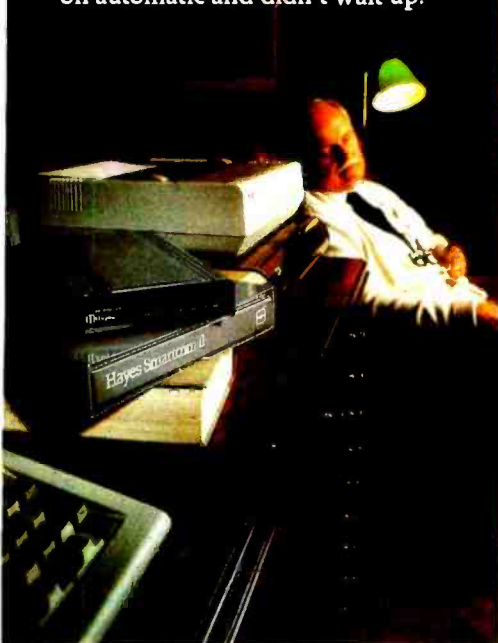

Your computer's telephone. Hayes

Wouldn't it be great if, somehow, you could connect your computer to your accountant's, down the street? To the IBM** PC at the branch office, upstate? Or to your favorite chess challenger, across country?

over ordinary phone lines, all across America.

But any modem will send and receive data.

Smartmodems also dial, answer and disconnect calls. Automatically. Without going through the telephone receiver, making them far superior to acoustic coupler modems.

Choose your speed; choose your price. The lower-priced Smartmodem 300 is ideal for local data swaps and communicates at 300 bps. For longer distance and larger volumes, Smartmodem 1200 communicates at 1200 bps or up to 300 bps, with a built-in selector that automatically detects transmission speeds.

Both work with rotary dials, Touch-Tone* and key-set systems; connect to most time-sharing systems; and feature an audio speaker.

Either Smartmodem is a perfect match for many different computers. And if you have an IBM PC, Hayes also provides the perfect communications software.

Smartcom II™ We spent a lot of time developing our software, so you can spend less time using it. Smartcom II prompts you in the simple steps required to create, send, receive, display, list, name and re-name files. It even receives data completely unattended—especially helpful when you're sending work from home to office, or vice versa.

And if you need it, there's always "help." One of several special functions assigned to IBM function keys, this feature explains prompts, messages, etc. to make communicating extra easy.

With Smartcom II, it is. The program remembers communication parameters for 26 different remote systems. Just punch a key, you're all set.

You can treat dial-up and log-on sequences the same way. In fact, Smartcom II comes with codes already set up for four popular information services, COMPUSERVE® DIALOG'S KNOWLEDGE INDEXSM, DOW JONES NEWS/RETRIEVALSM SERVICE, and THE SOURCESM AMERICA'S INFORMATION UTILITYSM. Procedures for obtaining an account with each of the services are included in the Smartcom II manual. But that's not all.

Special offers for Smartcom II

owners! Dow Jones News/Retrieval Service has a special introductory offer for Smartcom II owners. By calling a toll-free number, they receive a free password and one free hour of service anytime after 6:01 p.m., local time.

You'll also be entitled to a valuable



With a telecomputing system by Hayes, you can.

Quickly. Easily. And for the price of a phone call.

Hayes Smartmodem. Think of it as your computer's telephone. Hayes Smartmodem 300, and the faster Smartmodem 1200, work with any computer with an RS-232 I/O port. They allow you to communicate,



Welcome to TELEMAIL! Your last access was Tuesday, Jan. 4, 1983 11:07 a.m. CHECK these bulletin boards: TELEMAIL...TELESOFT...



subscription offer for THE SOURCE. Smartcom II owners who subscribe to THE SOURCE will receive one free hour of daytime service.

Like all our products, Smartcom II and both Hayes Smartmodems are backed by excellent

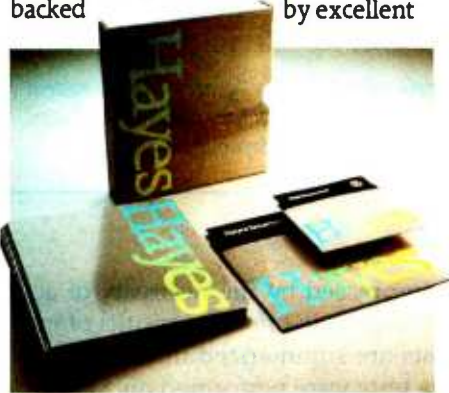

documentation and full support from us to your dealer.

So see him today. Break out of isolation. Get a telephone for your desktop computer.

Hayes Microcomputer Products, Inc.,
5923 Peachtree Industrial Blvd.,
Norcross, GA 30092. 404/449-8791.

Smartcom II is a trademark of Hayes Microcomputer Products, Inc.

*TM American Telephone and Telegraph
*IBM is a registered trademark of International Business Machines, Corp.

© 1983 Hayes Microcomputer Products, Inc.
Sold only in the U.S.A.

COMPUSERVE INFORMATION SERVICE is a registered trademark of CompuServe, Incorporated, an H & R Block Company.

KNOWLEDGE INDEX is a service mark of DIALOG Information Services, Inc.

DOW JONES NEWS/RETRIEVAL is a registered trademark of Dow Jones & Company, Inc.

THE SOURCE and AMERICA'S INFORMATION UTILITY are service marks of Source Telecomputing, a subsidiary of The Reader's Digest Association, Inc.

Listing 4: The prototype sort program tests each compiler's handling of pointers.

```

quick(lo, hi, base)    /* quicksort */
int lo, hi;
char *base[];
{
    int    i, j;
    char   *pivot, *temp;

    if (lo < hi) {
        for (i = lo, j = hi, pivot = base[hi]; i < j; ) {
            while (i < j && strcmp(base[i], pivot) <= 0)
                i++;
            while (j > i && strcmp(base[j], pivot) >= 0)
                j--;
            if (i < j) {
                temp = base[i];
                base[i] = base[j];
                base[j] = temp;
            }
            temp = base[i];
            base[i] = base[hi];
            base[hi] = temp;
            quick(lo, i - 1, base);
            quick(i + 1, hi, base);
        }
    }
}

getln(s, n)            /* get a line of up to n characters into s */
char s[];
int n;
{
    int    c, i;

    for (i = 0; n > 0; n--, i++)
        if ((c = getchar()) == EOF || c == '\n')
            break;
        else
            s[i] = c;

    s[i] = '\0';
    return (i);
}

#include "stdio.h"

#define MAX    1001    /* maximum number of entries */
#define MAXLINE 135    /* longest line expected */
#define NTIMES 10     /* number of times to sort entries */

main()                /* sort lines in memory */
{
    int    i, j, n, length;
    char   buf[MAXLINE], *sort[MAX], *unsorted[MAX], *alloc();

    for (n = 0; n < MAX; n++)
        if ((length = getln(buf, MAXLINE)) == 0) {
            n--;
            break;
        }
        else if ((unsorted[n] = alloc(length + 1)) == NULL) {
            printf("Sort: not enough room\n");
            exit(-1);
        }
        else
            strcpy(unsorted[n], buf);

    printf("%d iterations: ", NTIMES);

    for (i = 1; i <= NTIMES; i++) {
        for (j = 0; j <= n; j++)
            sort[j] = unsorted[j];
        quick(0, n, sort);
    }

    printf("%d entries.\n", n + 1);
    exit(0);
}

```

contained various utilities as well as test data for the copy and sort programs. This minimized variations in disk-access time during testing.

The test file for copy was 1000 lines of text—80K bytes in all. To get test data for the sort program, I created a file containing the first 1000 words of an earlier article I had written for BYTE. The words were placed in the file in the order they appeared in the article, each on a separate line. Finally, I reserved a disk for each compiler and copied onto it only those programs and files that were necessary for compilation of the test programs.

I compiled the test programs using a CP/M-80 SUBMIT script, which enabled me to automate the various commands that made up each compilation. Once again, my goal was uniformity. By letting the SUBMIT file control compilation, I eliminated any variation that might have been caused by changes in the speed of typing in commands by hand.

All timing measurements were made with a Hayes serial clock that was connected to the computer. The SUBMIT script used to compile the programs read the clock at the beginning and end of each compilation. Similarly, I used a multiple-command line under Microshell to read the time just before and after each program was executed. I performed each of the tests several times with each of the compilers. The variation in time—for either compilation or execution—never exceeded 1 second.

The Telecon compiler partially defeated my attempts at standardization. It takes two steps to invoke any Telecon program, including the compiler. The extra step is required by the Telecon "shell," a command interpreter that is made a part of every compiled program.

When you type the name of a program compiled under Telecon, CP/M-80 loads the program into memory, but instead of executing immediately, the program waits until you enter optional parameters to the shell. Even if the program doesn't require any optional parameters, you still have to enter an extra carriage return before it starts to run.

Program: primes (see listing 1)

Compiler	Execution Factor	Execution Time (Seconds)*	Compilation Factor	Compilation Time (Seconds)*	Bytes
Whitesmiths	1.00	60	12.82	423	15744
C/80	1.05	63	4.18	138	3584
Aztec	1.30	78	4.39	145	9168
BDS	1.43	86	1.00	33	3812
Telecon	1.45	87	12.61	416	5443

Program: fib (see listing 2)

Compiler	Execution Factor	Execution Time (Seconds)	Compilation Factor	Compilation Time (Seconds)	Bytes
Whitesmiths	1.00	153	12.59	403	15616
Telecon	1.10	168	12.59	403	5245
C/80	1.12	171	4.16	133	3217
BDS	1.32	202	1.00	32	6159
Aztec	1.55	237	4.16	133	8974

Program: copy (see listings 3a-3c)

Compiler	Execution Factor	Execution Time (Seconds)	Compilation Factor	Compilation Time (Seconds)	Bytes
BDS	1.00	144	1.00	41	6159
Aztec	1.07	154	4.05	166	11482
C/80	2.47	356	3.56	146	3840
Whitesmiths	2.86	412	11.80	484	18560
Telecon	3.85	554	10.29	422	5574

Table 2: Results of the benchmark tests. The tests were run on a "generic" S-100 system using a Z80 processor at 4 MHz, with 484K-byte double-density floppy disks. The relative execution speeds provide a valid comparison of the compilers' capabilities.

I used a stopwatch to time the first part of the Telecon compilations (the compiler proper) and my usual method with the Hayes serial clock for the rest (assembly and loading). The execution times for the Telecon programs were obtained in the same way as those for the programs created with the other compilers, but I had to enter the command-line arguments or the extra carriage returns by hand. Strictly speaking, the Telecon timings are not directly comparable to those of the other compilers.

The Results

I started this experiment hoping to find the best of the 8080 C compilers, if not a perfect one. I came away from

it impressed by the necessity of accepting trade-offs. The results of my tests are summarized in table 2. All the tests were performed on a Heath H8, using a Heath H47 disk drive with approximately 1.2-megabyte capacity and a Z80 processor running at 2 MHz. (Note that most Z80-based machines run at twice that speed, so for the processor-intensive programs—primes, fib, and sort—my tests took roughly twice as long as they would have on a computer with a 4-MHz clock.)

I must emphasize the relative nature of the test results: A program that takes 1 second on this computer system does not necessarily require 1 second on systems with different processor speeds or those with disk

Program: sort (see listing 4)

Compiler	Execution Factor	Execution Time (Seconds)	Compilation Factor	Compilation Time (Seconds)	Bytes
Aztec	1.00	129	5.36	209	11796
Whitesmiths	1.36	175	14.67	572	18304
C/80	1.94	250	4.28	167	4259
BDS	2.31	298	1.00	39	5631
Telecon	**				

** Could not compile program

String-Length Test (see listing 5a)

Compiler	Execution Factor	Execution Time (Seconds)
Whitesmiths	1.00	138
Aztec	1.25	172
BDS	1.43	197
Telecon	2.04	282
C/80	2.59	357

With Register Variable (see listing 5b)

Compiler	Execution Factor	Execution Time (Seconds)	Improvement
Aztec	1.00	72	58%
Whitesmiths	1.22	88	36%
C/80	2.65	191	46%
BDS	2.74	197	0
Telecon	3.92	282	0

drives having different access times from the drives used here. It is more useful to compare the compilation factors or execution factors listed for each compiler.

These factors are a measure of how each compiler performed with respect to the others. The compiler that produced the fastest time in each category has a factor of 1.00. All the other scores are proportionally higher. So if compiler *x* produced a program that took half again as long to run as the leader, its execution factor would be 1.50.

Whitesmiths C produced the fastest code in two of the four test programs, primes and fib. Aztec C was substantially faster than the others in the sort program. Aztec C and BDS

C, with their 1024-byte buffers, were the fastest in copying files. An interesting result was that C/80, which uses only a 256-byte buffer—half the size used by Whitesmiths C—beat Whitesmiths C in the copy test.

You can compile a program with the BDS compiler much more rapidly than with any of the others. It compiled and linked the test programs in about one-quarter of the time required by the next-fastest compiler. The C/80 programs were always the shortest. And, as I have noted, Aztec was the only compiler that accepted all the test programs without change. In the 8-bit world, at least, the Kernighan and Ritchie standard is something less than standard.

While I had to introduce quite a

few minor variations to get the test programs to work with each of the compilers, they all turned out to be fairly similar to their prototypes. That's what I wanted. It would have been possible to speed up some of the programs or to squeeze a few bytes out of them by using programming tricks to optimize the code for each particular compiler; but then the basis for comparison would be lost.

One "trick" is common to several of the compilers, however: the use of register variables. A register variable is kept in a machine register whenever possible. That means it can be accessed or changed somewhat more quickly than other automatic variables.

Of course, only a limited number of registers are available in any central processor. That is particularly true of the 8-bit processors for which these compilers produce their code. Excess register declarations are simply ignored.

I wanted to see how useful register variables might be with each of the compilers. To find out, I wrote a program that repetitively calculated the length of a string. I tested the string-length function with and without a register variable (see listings 5a and 5b; the results appear in table 2).

Note that the BDS and Telecon compilers do not appear to support register variables in any form. C/80, on the other hand, allows an unlimited number. They are obviously not stored in machine registers, but rather in absolute memory locations, presumably where they can be accessed by the 8080's LHL and SHLD load instructions.

The Aztec C Compiler

The Aztec compiler is a single program that produces an assembly-language output file. This is then assembled with a supplied relocating assembler and linked with the standard library routines, along with any other precompiled modules the user may have created, using a linking loader that also comes with the package. A separate library utility is provided to manipulate compiled program modules, such as the standard

Listing 5: Two versions of this string-measuring program test the speed of the compilers' code with (5a) and without (5b) register variables.

```
(5a)
#include "stdio.h"

#define NTIMES 25000
#define S "Now is the time for all good men to come to the aid of the parity."

main()      /* repeatedly measure length of string */
{
    int i;

    for (i = 1; i <= NTIMES; i++)
        strlen(S);

    exit(0);
}

strlen(s)   /* return length of string */
char *s;
{
    char *p;

    for (p = s; *s != '\0'; s++)
        ;
    return (s - p);
}
```

```
(5b)
#include "stdio.h"

#define NTIMES 25000
#define S "Now is the time for all good men to come to the aid of the parity."

main()      /* repeatedly measure length of string, register version */
{
    int i;

    for (i = 1; i <= NTIMES; i++)
        strlen(S);

    exit(0);
}

strlen(s)   /* return length of string */
register char *s;
{
    char *p;

    for (p = s; *s != '\0'; s++)
        ;
    return (s - p);
}
```

I/O library. The compiler can also generate code for the Microsoft M80 macroassembler and L80 linker. A second library of functions in Microsoft relocatable object format is supplied with the package.

A separate compiler produces Z80 code. I tried it out on the test programs used for this review. The code it generated was not significantly faster and only slightly tighter than that produced by the 8080 compiler. (The test results reflect the standard 8080 compiler.)

The Aztec compiler meets the full Kernighan and Ritchie standard. Actually, Aztec does not support bit fields—a redundant feature of the language—but it usually should be possible to move C source code from a Unix system to a CP/M-80 system and compile it without change.

The Aztec compiler was not the quickest of the lot. I didn't find it particularly easy to use. It did not generate the fastest code, nor the shortest. But then, it did not perform badly in any of these areas either. In

other words, it is a solid, professional piece of software that—not incidentally—can compile standard C source files.

One of the few features that did bother me was a dynamic storage-allocation function in the library that is nonstandard. A standard one is included with the package, but I had to add it to the library myself.

I found the library manager, by the way, to be serviceable but rather awkward. It allows the replacement only of separately compiled "modules," rather than individual functions, which would be more flexible. And the manual section on the librarian is written in complex, breathless prose that I found difficult to follow.

The link phase of the Aztec compilation process is the only one that I found annoyingly slow. The compiler and supplied assembler move along quite nicely, and then the whole process turns sluggish at link time. It is necessary to look up error diagnostics in a table. That's a nuisance. It would be much easier if the diagnostics were written directly to the console.

I found one minor bug. The compiler would not accept an initialization in the form:

```
char *p = "literal string"
```

which is a common C idiom.

The Aztec manual is quite usable, but it lacks, and needs, an index.

The BDS C Compiler

The BDS C compiler is composed of two programs. One handles the standard C preprocessor functions and parses the source code. The second program generates machine code in a relocatable format. During compilation, the first program invokes the second automatically without creating any intermediate object files, which is one reason why the BDS compiler works so quickly.

Another reason is that the compiler reads the entire source program into the computer's main memory instead of passing it through a "window," or small block of memory. (This does not impose a limit on final program size because various modules can be



This Programming professional deserves a lot more from his personal computer.

He's earned it. As a seasoned professional, he's learned to master some of the world's most advanced programming tools. Tools specially designed to meet the everyday demands of programming experts.

But as the owner of a personal computer, he's come to expect less. Less performance. Less sophistication. And less flexibility.

Why should programming a personal computer be any different?

Prior to the announcement of micro/SPF™ development software, experienced programmers felt programming a personal computer was a lot like playing with a toy. You couldn't take it seriously.

But today, there's micro/SPF™, a solution to elementary program editing tools now offered with most micro-computers.

With micro/SPF™ you get the same procedures and commands experienced programmers are accustomed to using at work. By mimicking features found in

standard SPF software, micro/SPF™ provides all the sophisticated utilities programming professionals expect.

Programming experts can take advantage of skills they've spent years perfecting.

Now, for the first time, mainframe software is available for personal computers. SPF screens are fully reproduced in logical sequence and each screen is formatted identical to those found in the SPF system.

In addition, micro/SPF™ comes equipped with the same primary and line commands, tutorial messages and program editor (with program function keys) experienced programmers are used to.

Programming professionals who've spent years perfecting the art of writing sophisticated code deserve to work with state-of-the-art tools, not toys. Find out how micro/SPF™ can help you do work-compatible programming on your personal computer today!



PHASER

PHASER SYSTEMS, INC 24 CALIFORNIA STREET
SAN FRANCISCO, CA 94111 (415) 434-3990

At a Glance

Name	Aztec C Compiler	BDS C Compiler	C/80 C Compiler
Type	C compiler and utilities for CP/M-80	C compiler and utilities for CP/M-80	C compiler and utilities for CP/M-80
Version	1.05G	1.5	2.0
Manufacturer	Manx Software Systems POB 55 Shrewsbury, NJ 07701	B. D. Software POB 9 Brighton, MA 02135	The Software Toolworks 14478 Glorietta Dr. Sherman Oaks, CA 91423
Price	\$199	\$150	\$49.95
Computer needed	8080-family microcomputer with floppy- or hard-disk mass storage and at least 56K bytes of main memory	8080-family microcomputer with floppy- or hard-disk mass storage and at least 40K bytes of main memory	8080-family microcomputer with floppy- or hard-disk mass storage and at least 48K bytes of main memory
Documentation	86-page loose-leaf manual	185-page loose-leaf manual	35-page loose-leaf manual
Audience	Systems and application software developers	Systems and application software developers, hobbyists	Systems and application software developers, hobbyists

compiled separately and linked together.) Still another reason for the remarkable speed of the BDS compiler is that there is no assembly-language phase: the code produced by the compiler is ready to be linked with the BDS linker.

A library utility is supplied to manipulate the relocatable object modules produced by the compiler. These are not compatible with the commonly used Microsoft relocatable format, and the BDS compiler doesn't have an option for generating Microsoft-format code. A symbolic debugging program is included with the BDS package sold by some distributors. If it is not included, it is available from a users group at a low cost.

The BDS compiler makes no claim to accepting Kernighan and Ritchie standard code. There are a number of variations from the standard that are well documented in the manual. These are mostly restrictions of one kind or another. So BDS code, per se, should normally compile under Unix.

Unfortunately, the buffered file I/O functions supplied with the BDS library are not standard. In some cases, they appear to be designed for greater efficiency or ease of implementation under CP/M-80. In other cases, the changes serve no ap-

parent purpose except to limit portability between standard C code and BDS C.

The code generated by the BDS compiler was somewhat slower than average, although the object programs were relatively compact. BDS C programs can often be speeded up considerably by intelligent use of the preprocessor and by recoding some of the library functions into assembler. I know of at least one package of BDS C assembly-language functions that is available from a number of CP/M computerized bulletin-board systems around the country.

A considerable amount of other BDS C source code exists in the public domain—everything from games to quite sophisticated system utilities—and there is a national users group to help distribute it. This stockpile of public-domain software exists because BDS C was the first C compiler to become available for CP/M-80.

What distinguishes the BDS compiler, aside from the fact that it has been on the market longer than the others, is its ease of use. The entire package is a programmer's delight. It's not just their speed that sets the programs in this package apart. They are clean and comfortable and intuitive. The source code for the library and run-time routines is com-

plete and well documented. A larger-than-average number of utilities and sample programs is included with the package. The BDS manual is lucidly written and includes a good deal of technical information about the generated code.

The C/80 C Compiler

The C/80 compiler is a single program that produces assembly-language code. The compiler output is not compatible with CP/M-80's ASM assembler; but an absolute assembler that produces executable machine code (not relocatable) comes with the package. Standard library routines are supplied in assembly language and are automatically included in every C/80 assembly. C/80 has an option to generate assembly-language code in Microsoft format, and a second library is supplied as a Microsoft-compatible, relocatable object file.

The C/80 compiler was born as a revision of the public-domain C compiler that was published by Ron Cain in *Dr. Dobb's Journal* back in May 1980 ("A Small C Compiler for the 8080's"). C/80 has grown far beyond its public-domain origins, however, and now supports a sizable subset of the Kernighan and Ritchie language. Like the BDS C compiler, C/80 is not a complete implementation. The I/O library in particular leaves something

MAXI PROGRAMMING FOR MICRO-COMPUTERS



Let ALCOR Language Systems Transform You Into a Professional Programmer

ALCOR languages can guide you step-by-step from novice programmer to a seasoned professional. All of our systems are easy to use and share a clean, simple interface. In fact, all systems require only two commands to compile and execute a program!

Are You Tired Of Struggling With The Documentation?

No longer will you have to fumble through poorly written manuals filled with a peculiar dialect of progamese. Each of our languages come with a complete and well organized documentation set that includes a special language tutorial for new programmers.

Never again will you have to figure out whether a problem is a language bug or a programming error.

For reliability, all ALCOR language compilers utilize state-of-the-art design techniques. The result is unequaled reliability and performance.

Mainframe power and sophistication on micro computers.

Are you tired of being told that the other language is a subset of the real thing? All ALCOR language systems are complete language implementations with all



of the features expected in professional programming environments.

Compatibility is a reality, not an advertising gimmick.

All ALCOR languages were designed by our own highly trained and professional staff of programmers. Not borrowed or copied, but exclusively created by us so that you can develop libraries of routines in any language that are callable from any other language.

ALCOR language systems run on a wide range of computer and operating system combinations.

Professional programmers know that the portability of a program is a crucial factor in applications. Rewriting applications every time you change computers is a waste of your valuable time and unnecessary with ALCOR languages.

If you want to develop quality software, do it with the quality language system from ALCOR.

MULTI-BASIC—A revolutionary approach to compiler design. **MULTI-BASIC** is the first language system to solve the BASIC compatibility problem. Not only does it support powerful features such as recursion, it compiles both MBASIC and CBASIC programs!

C—ALCOR C is the perfect tool for systems programmers. It is a complete C implementation as described in the Kernigan and Ritchie book "The C Programming Language."

PASCAL—A powerful Jensen and Wirth standard Pascal that is packed with the features necessary for serious program development such as random access files, dynamic strings and separate compilation.

These language systems are now available for most Z-80 based micro-computers with CP/M or TRSDOS compatible operating systems. 8086 and 68000 versions soon.

Yours for the asking!

Yes! Please rush via return mail your information package describing these new languages now available.

- Pascal
- Multi-Basic
- C Language.

Name _____

Address _____

City _____

State _____

Zip _____

FREE information-packed brochure. Call or write today to:



800 W. Garland Avenue, Suite 204
Garland, TX 75040
Telephone: (214) 494-1316

Dealer, Distributor and OEM Inquiries Invited.

TRS-80 and TRSDOS are trademarks of Tandy Corporation. CP/M and CBASIC are trademarks of Digital Research. MBASIC is a trademark of Microsoft.

© 1983, ALCOR Systems, Garland, Texas



Apple® II, IIe 5 megabyte Removable HARD_DISK™ \$1,295

HARD_DISK is designed for fast access to large data files. The Removable **HARD_DISK PAC™** can even replace floppy diskettes as a very reliable backup media and eliminate the need to add floppy disk drives.

One Year Warranty
205-871-0987

Digital Electronics Systems
107 Euclid Avenue
Mountain Brook, AL 35213

HARD_DISK, PAC are trademarks of Digital Electronic Systems, Inc.
Apple II, IIe is a trademark of Apple Computer, Inc.

At a Glance

Name	Telecon C Compiler	Whitesmiths C Compiler
Type	C compiler and utilities for CP/M-80	C compiler and utilities for CP/M-80
Version	2.7	2.1
Manufacturer	Telecon Systems 1155 Meridian Ave., Suite 218 San Jose, CA 95125	Whitesmiths Ltd. 97 Lowell Rd. Concord, MA 01742
Price	\$200	\$750
Computer needed	8080-family microcomputer with floppy- or hard-disk mass storage and at least 48K bytes of main memory	8080-family microcomputer with floppy- or hard-disk mass storage and at least 60K bytes of main memory
Documentation	16-page loose-leaf manual	loose-leaf manual of more than 300 pages
Audience	Hobbyists	Systems and application software developers

to be desired. But given the \$50 sales price, you would have to be crazy to complain.

Its limitations notwithstanding, C/80 is not a toy compiler. The code it generated for the test programs was reasonably fast and the most compact produced by any of the compilers that I tested. C/80 is obviously capable of doing serious production work. Walt Bilofsky's Software Tools, which sells C/80, also markets several other products that were compiled with it.

C/80 writes object files in 256-byte chunks, so there was sometimes a discrepancy between the size of the object code as reported by the compiler and the number of 128-byte CP/M-80 sectors that were actually written to disk. (My statistics reflect the latter.)

The C/80 package includes a very valuable development tool: a profiler, a program to measure which parts of the code a program spends the most time executing. Unfortunately, it is of limited utility to those without Heath/Zenith computers because it uses a clock counter maintained by the Heath system software. A trace program is also included. It provides a list of each function call and return in the executing object program. The

C/80 manual is short but well organized and well written.

The Telecon C Compiler

The Telecon C compiler, also a single program, produces code for the standard CP/M-80 absolute assembler, ASM. Library routines are incorporated into the compiler output from an assembly-language file that is supplied with the package. The manual states that the compiler is capable of producing code for a relocating assembler but gives no hint about the format or what additional programs are required to assemble it. The compiler produced serviceable code that ran a bit slower than average but was relatively short.

The Telecon library is nonstandard and incomplete. There is no dynamic storage-allocation function, for example, so I could not compile the sort program. As noted earlier, I found one bug: the compiler won't accept array subscripts that involve the addition of constants.

The Telecon shell, a command interpreter that is included in every compiled program, makes this compiler rather different from the rest. Telecon programs do not execute in the normal manner. After you invoke them, you are required to type in op-

How can your microcomputer talk to an IBM mainframe?

CLEO.



The communications features of the CLEO-3270 Software package allows your microprocessor to emulate a cluster of IBM terminal devices.

You don't even need to change software on your mainframe computer, because for all it knows, it's communicating with a 3271-12, 3275-12, or 3276-XX cluster. And the program will accommodate up to 8 terminals.

The CLEO software provides the cluster emulation and makes the ASCII devices look like an IBM 3278 CRT and 3287 printer.

If your IBM mainframe doesn't support remote 3270 clusters, you need remote batch communications. CLEO-3780 Software is your answer.

For full details contact Phone 1, Inc., 461 North Mulford Road, Rockford, IL 61107; phone (815) 397-8110.

Circle 316 on Inquiry card.

Standard Features-CLEO 3270

- Bisynchronous 3276-2 protocol to 9600 baud
- SDLC 3271-12 and 3275-12 protocol
- Up to eight line cluster activity
- Selectable control unit address
- User install program for various CRTs
- 3278 emulation for ASCII CRTs
- Available for CP/M™, MP/M™, MsDOS™, TurboDOS™, Unix™, and Xenix™.
- Coded in C language
- 3276-12 protocol, coming soon

Standard Features-CLEO 3780

- Point-to-point and multipoint communications
- Available for CP/M™, MP/M™, MsDOS™, TurboDOS™, Unix™, and Xenix™.
- Supports transparent mode
- Coded in C language

CLEO



tional arguments that would normally be placed on the CP/M-80 command line. Even if the program doesn't require any arguments, it still needs a carriage return before it starts to run.

It is possible to work around this to some extent by using the CP/M-80 XSUB facility or a Microshell command file. But the compiler would be much more useful, in my opinion, if the shell feature were optional or were left out altogether. The Telecon manual is poorly written, badly organized, and incomplete.

Whitesmiths C Compiler

The Whitesmiths C compiler is supplied as three separate programs—a preprocessor, a parser, and a code generator—each of which produces intermediate files. The output of the code generator is assembly-language code for Whitesmiths proprietary A-Natural assembler, an interesting program in itself, which permits assembly-language programming in a notation that is somewhat

more intuitive and high level than standard assembly-language mnemonics and syntax.

A linker is supplied to combine the output of the assembler with the standard library. The relocatable output of the Whitesmiths assembler is not Microsoft-compatible. A separate program is included for library manipulation.

The Whitesmiths compiler generated code that was fast but long. The manual describes some tricks to reduce the size somewhat. For example, the run-time support for redirection of input and output can be removed. But even so, the Whitesmiths programs would be relatively big.

It takes five separate programs to compile, assemble, and link a Whitesmiths source file: the preprocessor, the two-compiler stages, the A-Natural assembler, and the linker. That is a slow process. My four test programs took from 4¾ to 6¾ minutes to compile and link—roughly 12 times as long as with BDS C, the fastest compiler.

While Whitesmiths C is a complete C implementation, it does not meet the Kernighan and Ritchie standard. The assignment operators follow the Unix version 6 compiler. That is, to increase n by 2, you use:

$n = + 2$

instead of

$n += 2$

which is what Kernighan and Ritchie and the current Unix compilers call for.

The Whitesmiths I/O library is complete, but it is idiosyncratic. Many of the differences are trivial—different names for the string functions, for example, or for the arguments to the formatted printing function, `printf`—but there are some functional differences as well. All in all, Unix code will generally not compile under Whitesmiths C, version 2.1.

Whitesmiths C does give every impression, however, of being an exceptionally solid and professional product. While I did not attempt anything that even resembled a full validation test, I got the feeling when working with the Whitesmiths compiler that it will perform exactly as the documentation states. The documentation is a bit hard to use—one of the features that was modeled quite literally after Unix—but it is detailed and complete. Alas, it has no index.

The Envelope, Please

I had hoped to find one C compiler that was clearly the best of the lot. I didn't, but I know now what I am looking for. It should adhere to the Kernighan and Ritchie standard as closely as Aztec C, perform compilations as rapidly and have as clean an implementation as BDS C, be as dependable as Whitesmiths C, and be priced like C/80. Any takers? ■

Chris Kern (Apartment 839, 201 I St., SW, Washington, DC 20024) is a journalist and computer hobbyist. He wrote BYTE's first review of a C language translator, "A User's Look at tiny-c," which appeared in the December 1979 issue, page 196.

Texas Instruments Model 850...
the new American-made printer
that beats the imports on price,
performance and compatibility.

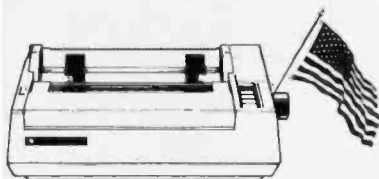

Buy, lease or rent the new TI 850 desktop printer from MTL.

150 cps, 9x9 dot matrix, both bit image and mosaic graphics with better resolution, easier font-changing, both parallel and RS232 interfaces standard. These are just a few of the features of the new TI Model 850. Truly a sensational printer designed to be compatible with your desktop personal computer.

MTI is an authorized distributor of Texas Instruments' full line of portable terminals, matrix printers and Professional Computers. Whether you buy, lease or rent our equipment, you'll find MTI is the one source for all the terminals, peripherals, systems, applications expertise and service you'll ever need. Priced right. Call us.

New York: 516/621-6200, 212/767-0677, 518/449-5959
Outside N.Y.S.: 800/645-6530
New Jersey: 201/227-5552
Ohio: 216/464-6688

"QED" Discounts
VISA & MasterCard



Applications Specialists & Distributors, New York, New Jersey and Ohio.
DEC, Intel, Lear Siegler, Texas Instruments, Dataproducts, Diablo, 3Com,
Hazeltine, Racal-Vadic, Digital Engineering, MICOM, Cipher, U.S. Design,
Protocol Computers, MicroPro, Microsoft, Polygon and Select.

Powerful CP/M[®] Software.

For Apple, Osborne, Xerox, Kaypro, North Star, SuperBrain, Heath/Zenith, and others.

Now only **\$29.95** each!

NEVADA

COBOL

was \$199.95 now only **\$29.95.**

When we introduced Nevada COBOL in 1979, it was loaded with innovations. Today's Edition 2 is even better!

- Extremely Compact. You can compile and execute up to 2500 statements in 32K RAM, 4000 statements in 48K, etc.
- It's based upon the ANSI-74 standards with level 2 features such as compound conditionals and full CALL CANCEL.
- You can distribute your object programs royalty FREE!
- You get a diskette, 153-page manual with lots of examples and 16 complete COBOL source code programs.

Also available: COBOL Application Packages, Book 1 \$9.95

NEVADA

PILOT

was \$149.95 now only **\$29.95.**

- Perfect for industrial training, office training, drill and testing, virtually all programmed instruction, word puzzle games, and data entry facilitated by prompts.
- John Starkweather, Ph.D., the inventor of the PILOT language, has added many new features to Nevada PILOT. There are commands to drive optional equipment such as Video Tape Recorders. There's a built-in full-screen text editor, and much more.
- Meets all PILOT-73 standards for full compatibility with older versions.
- You get a diskette, 114-page manual and ten useful sample programs.
- See Review in *Microcomputing*, January 1983, page 158.

NEVADA

FORTRAN

was \$199.95 now only **\$29.95.**

- Based on ANSI-66 standards with some 1977 level features.
- IF . . THEN . . ELSE constructs.
- A very nice TRACE style debugging.
- 150 English language error messages.
- You get a diskette, 174 pages of Documentation and five sample programs. Requires 48K RAM.

NEVADA

EDIT

was \$119.95 now only **\$29.95.**

- High quality text editing for micros!
- A character-oriented full-screen video display text editor designed specifically to create COBOL, BASIC and FORTRAN programs.
- Completely customizable tab stops, default file type, keyboard control key layout and CRT by menu selection.
- The diskette comes with an easy to read manual.

To make our software available to even more micro users, we've slashed our prices. What's more, we're offering a money back guarantee. If for any reason you're not completely satisfied, just return the package—in good condition with the sealed diskette unopened—within 30 days and we'll refund your money completely.

This is a limited time offer, so order yours today!

Shipping/handling fees. Add \$4.00 for first package and \$2.00 each additional package. OVERSEAS Add \$15.00 for first package and \$5.00 each additional package. Checks must be in U.S. funds and drawn on a U.S. bank!

Trademarks: CP/M, Digital Research; TRS-80, Tandy Corp.; TeleVideo, TeleVideo Systems, Inc.; Apple II, Apple Computer Inc.; Osborne 1, Osborne Computer Corp.; Xerox 820, Xerox Corp.; Kaypro, Non-Linear Sys.; Heath/Zenith, Heath Co.; IBM, International Business Machine, Corp. © 1983 Ellis Computing.

MAIL TODAY! To: Ellis Computing
3917 Noriega St.
San Francisco, CA 94122
(415) 753-0186



ELLIS COMPUTING

The CP/M-80[®] Operating Systems and 32K RAM are required.

Indicate diskette format:

- | | |
|---|--|
| 8" <input type="checkbox"/> SSSD (Standard IBM 3740 format) | <input type="checkbox"/> Osborne |
| 5 1/4" <input type="checkbox"/> Apple CP/M | <input type="checkbox"/> North Star SD |
| <input type="checkbox"/> North Star DD | <input type="checkbox"/> TRS-80 Mod I/Mapper |
| <input type="checkbox"/> TRS-80 Mod I (4200 hex) | <input type="checkbox"/> Heath, Soft Sector |
| <input type="checkbox"/> Heath, Hard Sector | <input type="checkbox"/> Superbrain DD DOS 3.X
(512 byte sectors) |
| <input type="checkbox"/> Micropolis Mod II | <input type="checkbox"/> TeleVideo |
| <input type="checkbox"/> Xerox 820 (Kaypro) | |

Indicate software packages: COBOL PILOT
 FORTRAN EDIT

Send my order for _____ packages @ \$29.95 each Total
COBOL Applications Package @ \$9.95 each Total

Check enclosed In CA add sales tax
Shipping/handling
 MasterCard VISA TOTAL
 # _____ Exp. Date _____

Signature _____
 Ship to:
 Name _____
 Street _____
 City/St/Zip _____
 Country _____

dBASE II™ / \$398

The most widely sold DBMS for micros, dBASE II defines the state of the art. An inexperienced user can create a dBASE file, begin data entry, and print out a report in minutes; the experienced programmer can create complex program systems using dBASE's unique programming language. Both can use automatic program generators and other programming tools to create applications quickly and easily.

QUICKCODE: Automatically creates menus and "intelligent" data entry screens which check input for correctness. Eliminates 80-100% of dBASE programming time! **\$185.00**

dUTIL: Formats programs to make them easier to read, detects some errors and combines program files to make them run faster. **\$59.00**

dGRAPH: Allows you to see your dBASE file in graphic form—a real aid to understanding. **\$195.00**

ABSTAT: Allows you to analyze your data using a wide variety of statistical tests. Can be used with dBASE files or by itself. Also does bar graphs and plots. **\$359.00**

More Summer Specials!

MULTIPLAN™ / \$189

The world's hottest-selling spreadsheet, Multiplan™ is now setting the standard for ease of use and quality of documentation. Each of the Multiplan™ series comes complete with sophisticated training programs.

Multi-Tool Budget 'expert system': used with Multiplan™, enables new users to get budgets out in minutes. **\$69**

Multi-Tool Financial Statement: Expert help in getting out financials. **\$109**

EDIX & WORDIX / \$279

EDIX is a full-screen editor specifically designed to take advantage of the advanced features of the IBM PC; WORDIX is the best text formatter on the market. Together, they are an unbeatable combination, the finest word processor available on a micro—at an unbeatable price!

EDIX alone **\$149**
WORDIX **\$149**

SMARTMODEM 300 \$209 1200 \$509

These Hayes Stack Modems link your computer's RS232 serial port directly to a modular phone jack. They will dial the phone for you, and answer it as well. The Smartmodem 300 runs at 0-300 baud; for those needing higher speed, the Smartmodem 1200 can run at 1200 baud.

NEW! NEW! NEW!
Smartmodem 1200B: for the IBM PC only **\$469**

TERMS: All prices subject to change without notice and availability. Cashier's check/MO/bank transfer. Allow time for company or personal checks to clear. Prices reflect cash prepaid discount. VISA/MASTERCARD/COD/PO's + 3%. CA residents add sales tax. All sales final for games & special orders.
SHIPPING: \$3 per item for UPS surface (\$6 for Blue Label) within Continental USA, except where shipping cost is specified in square brackets. UPS does not go to Canada, Alaska, APO's, FPO's; call for ship charge or add 15%—we will refund/credit difference.
RETURNS: Must have authorization number, obtained at 415-324-0305. Unauthorized returns will be refused; damaged goods will be refused. All returns subject to 15% restocking fee. No return after 30 days.

Orders must be PAID by AUGUST 31 to qualify for these special prices

PROGRAMMING INTERNATIONAL

(800) 222-8811
Inside California:
(415) 324-3730

Your IBM PC Source

PROGRAMMING INTERNATIONAL

PC Software—MS/DOS		Howard Software		PC Hardware		Symtec	
Advanced Operating Systems	LIST SALE	Real Estate Analyzer	250 185	64K RAM	350 249	Light Pen	150 126
The Programmer ...	200 150	Tax Preparer 1983	250 185	64K RAM Chip Set	175 139	Tandon	
Alpha Software		Information Solutions, Inc.		128K RAM	525 379	TM100-2 Drive	
Apple-IBM Connection	195 135	25:01 The 25th Hour	100 74	192K RAM card	700 499	(5 1/4" DS)	[5] 650 249
Database Manager	245 169	IUS		256K RAM card	875 624	TG	
Mail List	95 67	Easy Filer	400 279	Corvus		Joystick	65 49
Typefaces	125 87	Easy Planner	250 188	PC Interface, Cable, Man	300 239	Trackball	65 49
American Training International		Easy Speller 2	225 135	Kraft			
Power for PC DOS	75 56	Easy Speller 2/Legal	350 229	Joystick	70 52		
Applied Software Technology		Easy Speller 2/Medical	350 229	Microsoft			
QBASE	189 143	Easy Writer II	350 229	Mouse	195 149		
Versaform	389 259	Financial Mgmt (AR/AP/GL)	[5] 1495 1019	Northwest Analytical			
Aptek		AR	595 389	Statpak	495 369		
Epson to Prism	38	AP	595 389	Oasis			
PC Ticker Tape	22	AR	595 389	Punctuation & Style	100 109		
Rainbow Writer	125	GL	595 389	The Word Plus	150 112		
Ashton-Tate		Inventory	595 389	PBL Corporation			
dBASE II	[5] 700 398	Order Entry	595 389	Personal Investor	145 98		
dBASE II w/User's Guide	[5] 729 419	Payroll	595 389	PC Software			
Financial Planner	700 489	Innovative Software		Database	75 67		
Aspen Software		Fast Graphs	295 159	Peachtree			
Grammatik	75 56	TIM III	495 279	Printtext 5.00	305 271		
Proofreader 32K	50 38	Insolt		Slides 4 Pak (incl. AP)	[5] 595 349		
Proofreader 50K	50 38	Data Design	225 169	Peter Norton			
Proofreader 80K	50 38	Intellect Associates		Under	80 60		
Beaman Porter		PC Text	100 73	Ryan McFarland			
Powertext	399 369	Window	150 113	Androlab Full Dev System	950 713		
Best Products		ISM		RM/Cobol Runtime	250 188		
Personal Financial pgm	95 66	Graphmagic	90 65	Scripts Data			
Bible Research		Graphmagic Combo	150 119	Job Coasys	495 371		
THE WORD Processor	146	Mathemagic	90 65	Select Information Systems			
BPI		Lexisoft		Wordprocessor	595 356		
Personal Accountant	195 160	Spellbinder	495 259	Software			
Byrom Software		Lifeboat		Wordmak	500 340		
BSTAM	200 149	C-Food	150 125	Software Arts			
BSTMS	200 149	Smorgasbord	150 125	IKolve	224		
Cavaller		Lattice C Compiler	500 415	Software Products International			
Championship Blackjack	40 30	Lifetree		Logicalc	195 142		
Central Point Software		Volkswriter	195 129	Logiquest II	250 188		
COPY II Plus	40 25	Lighting	50 38	Logiquest III	550 372		
Comprehensive Software Support		Printer Type Link Systems	299 224	Procalc	350 262		
PC Tutor	80 60	Data Fax Lotus	495 369	Software Publishers			
Comshare		1-2-3	495 369	PFS: File	140 105		
Financial Modeling	325 264	Mark of the Unicorn		PFS: Report	125 94		
Conceptual Instruments		Personal Word Mince	300 223	Sorcim			
Desk Organizer	245	MDBS		Supercalc	295 185		
Condor		Knowledgeman	500 327	Superspread	195 129		
Condor 1	295 185	Metasoft		Supersync	295 179		
Condor 3	650 398	Benchmark Mail List	250 184	Southeastern			
Continental Software		Benchmark Word processor	500 367	Data Capture	120 90		
FCM (First Class Mail)	125 79	Micro Lab		Supersoft			
Home Accountant Plus	150 99	Tax Manager	250 188	Optimizer	200 149		
Conceptual Instruments		Micro Pro		Personal Data Base	125 93		
Desk Organizer	245	Infostar	[4] 495 327	Synapse Video			
Condor		Mailmerge	250 165	File Manager	150 112		
Condor 1	295 185	ReportStar	350 231	Synergistic			
Condor 3	650 398	Spull 101	250 165	Data Reporter	250 169		
Continental Software		Word Mail	[4] 695 426	Texasoft			
FCM (First Class Mail)	125 79	Word/Spell/Mail	[4] 695 426	Thinker	75 56		
Home Accountant Plus	150 99	Word/Spell/Mail	[4] 845 558	Versatext	200 172		
Comshare		Wordstar	[4] 495 327	Versa Computing			
Financial Modeling	325 264	Microcraft		Graphics Hardcopy	25 19		
Conceptual Instruments		Legal Billing/Timekeeping	750 385	Versawriter	299 249		
Desk Organizer	245	Professional Billing/Time	750 385	Visicorp			
Condor		Microsoft		Business Forecasting Model	100 78		
Condor 1	295 185	BASIC Compiler	250 165	Desktop Plan	300 229		
Condor 3	650 398	Business BASIC	50 38	Visicalc	250 169		
Continental Software		Flight Simulator	250 188	Visidex	250 189		
FCM (First Class Mail)	125 79	µLisp/µStart	250 188	Visifile	300 219		
Home Accountant Plus	150 99	Multiplan	275 189	Visischedule	300 234		
Conceptual Instruments		µMath/µSimp	300 225	Visispell	225 183		
Desk Organizer	245	Pascal		Visitrend/plot	300 215		
Condor		Microstuf		Visiword	375 298		
Condor 1	295 185	Crosstalk/Smartmodem	195 135	Woolf			
Condor 3	650 398	North American		Move It	150 99		
Continental Software		<<ANSWER>>	250 159				

Summer Special!

TELEPHONE ORDERS

Outside Calif.: (800) 222-8811
 Inside Calif.: (415) 324-3730

Order lines are manned 8:30-6 Monday thru Friday and 9-5 Saturday. Other lines are open 9-5 Monday thru Friday

Technical Support (415) 324-0311
 Order Status (415) 324-0306
 Sales Manager (415) 324-0305

More CP/M*, APPLE*, IBM PC*, UNIX*, UCSD p-System* software, hardware, etc: call for quote.

505 Hamilton Avenue, Suite 301
 Palo Alto, California 94301

Nine C Compilers for the IBM PC

Several versions of C are available for the IBM PC and the MS-DOS operating system—one of the most lucrative software markets for applications written in C

by Ralph A. Phraner

The IBM Personal Computer, a popular software-development vehicle for Intel's 8086 family of processors, is blessed with a profusion of peripherals. This environment has encouraged a dozen C language compilers so far, and several more will soon be added to the list.

After first outlining some general differences in compiler implementation, we'll take a look at nine compilers: c-systems C, Caprock small-c, Computer Innovations C86, DeSmet C, Intellect Associates C88, Lattice C (Microsoft C), Quantum C, Supersoft C, and Telecon C. One comes bundled with its own operating system, four run only under PC-DOS (the IBM PC version of Microsoft's MS-DOS), and the four remaining are available for either PC-DOS or the CP/M-86 operating system.

About C

Why all this interest in a low-level systems-programming language? The president of a commercial systems software house recently said that C has only two real advantages over other worthy programming languages: it is the only one he could get competent assembly-language programmers to use without significant backsliding in effort and enthusiasm and the only one that does not need

to be extended to be useful. The latter point explains why, while subsets abound, there are virtually no non-standard C supersets (a weakness in Pascal and FORTH) and thus no intentionally variant implementations.

C is a language of concise, consistent, pragmatic structure; its specification is widely available in a book that, in addition to providing a formal definition for the language, also includes many small teaching programs. Implementers are more likely to adhere to the standard because adherence is easy to verify. This contributes to the portability of programs written in C. Even the compiler writer can transport his tools and programs from an old machine to the new one with a minimum of effort.

Benchmarking

For the record, the evaluation and testing was done on an IBM PC equipped with Intel's 8087 numerics coprocessor, two single-sided 160K-byte disk drives, and PC-DOS 1.1. The machine's 832K bytes of memory were partitioned under PC-DOS to allot 192K bytes for the operating system; the remaining 640K-byte segment was used as a semiconductor disk emulator addressable as any of three logical drives, A:, B:, or C:.

Until performance profiling and ex-

ecution tracing by function become standard microcomputer software workbench features, the soft spots in software and compiler design remain obscure. In an effort to uncover some of these differences, I included a set of small, simple functions in the evaluation process. These were designed to test separate facets of the compilers' construction and function to show how they vary in incremental code size and execution speed.

The integer math and elemental pointer benchmarks (listings 1 and 2 on page 142) illustrate the simple approach used. The outer-loop count is kept the same in all functions, so its influence is effectively factored out of the results. The integer-math code spends roughly equal processor time in each of the four operators and, by scaling, allows the evaluation to include byte-byte, byte-word, and word-word sized operand pairs. Boundary conditions are intentionally avoided. The pointer function, so simple as to be self-explanatory, is one way to measure efficiency in pointer use for array access.

The benchmark sieve.c is identical (no register variables, no moving the array inside the function body) to the benchmark code published in Jim and Gary Gilbreath's article, "Eratosthenes Revisited: Once More

At a Glance

Name

c-systems C compiler version 1.14

Type of Software Package

C programming language compiler

Manufacturer

c-systems
POB 3253
Fullerton, CA 92634
(714) 637-5362

Price

Compiler: \$195
Debugger: \$195

Format

5¼-inch double-density single-sided IBM
PC-compatible PC-DOS format floppy disks

Type of Compiler

Produces assembly language

Computer Needed

IBM-PC running PC-DOS with two single-sided disk drives and a minimum of 128K bytes of RAM; IBM Macro Assembler required for use

Documentation

46-page loose leaf manual

Audience

Systems and applications software developers. C programmers

Name

Small c: PC 1.1 PC-DOS version N

Type of Software Package

C programming language compiler

Manufacturer

Caprock Systems Inc.
POB 13814
Arlington, TX 76013
(817) 261-4493

Price

\$35

Format

5¼-inch double-density single-sided IBM
PC-compatible PC-DOS format floppy disk

Type of Compiler

Produces assembly language

Computer Needed

IBM PC running PC-DOS with two single-sided disk drives and a minimum of 64K bytes of RAM; IBM Macro Assembler required for use

Documentation

17-page staple-bound manual

Audience

Experimenters, students, and hobbyists who want to learn more about C

Name

CI-C86 C compiler version 1.33b

Type of Software Package

C programming language compiler

Manufacturer

Computer Innovations Inc.
10 Mechanic St.
Red Bank, NJ 07701
(201) 530-0995

Price

\$395

Format

5¼-inch double-density single-sided IBM
PC-compatible PC-DOS or CP/M-86 format floppy disks

Type of Compiler

Produces object code

Computer Needed

IBM PC running PC-DOS or CP/M-86 with two single-sided disk drives and minimum of 96K bytes of RAM

Documentation

143-page loose-leaf manual in vinyl ring binder

Audience

Systems and applications software developers. C programmers

through the Sieve" (January 1983, p. 284) and allows general comparison with benchmark figures in that article and in other compiler reviews in this issue. Float.c was used to allow comparison between 8087 use on the PC and other systems that use the 8087 at its full speed, as well as to show the relative performance of the compilers reviewed here. (Refer to "Comparing C Compilers for CP/M-86," on page 82 of this issue for details about this benchmark. You will also find information about benchmarks in Christopher O. Kern's "Five C Compilers for CP/M-80" on page 110.)

The compiler group as a whole showed the least execution time variance in efficiency of function calling (which may explain the close grouping of results from the fibo.c benchmark used in the two articles mentioned above). See tables 1 and 2 for the results of the benchmarks. The greatest variance was for func-

tions measuring performance in address arithmetic. Function-calling measures (with and without argument passing) showed that those compilers that implement register variables always incur a penalty in code size and execution speed, whether this feature is actually used or not. Test results are dramatic and slow some of the top-rated code generators to the crawl of the poorest performers. Quantum C and c-systems suffered heavily from saving the 8088's SI and DI registers on each and every function call, regardless of whether they are actually used, and restoring them both on every return.

Implementation Differences

Peculiarities and variations in how a compiler is written point up some criteria to consider.

Does it use the linker supplied with the native operating system or one of its own unique format? By using the standard linker supplied with the operating

system, the compiler's usefulness and flexibility are greatest because assembly language interface is simplified.

Does it generate object code or assembly language? Object-code generation often results in faster compile times and more efficient compiler-code optimization. If assembly language is produced, the effective compiler price must be increased by the \$100 price of the IBM Macro Assembler (as in the case of PC-DOS), unless you already own one or (as in the case of the DeSmet compiler) one is provided. Perhaps more important is the time penalty that an assembler extracts from the programmer. On the other hand, assembly-language generation might be necessary if much low-level hardware or operating-system interfacing is needed or if any time- or space-critical code is to be written. If the compiler's output is assembly language, code optimization for speed or compactness offers

ERG/68000 MINI-SYSTEMS

- Full IEEE 696/S100 compatibility

HARDWARE OPTIONS

- 8MHz, 10MHz or 12MHz 68000 CPU
- Memory Management
- Multiple Port Intelligent I/O
- 64K or 128K STATIC RAM (70 nsec)
- 256K/512K or 1MB Dynamic RAM, with full parity (150 nsec)
- 5 1/4" - 8" D/D, D/S floppy disk drives
- 5MB-40MB hard disk drives
- Full DMA Disk Interface
- SMD Disk Interface
- 1/4" tape streamer
- 10 to 20 slot backplane
- 20 or 30A amp power supply
- Desk top or Rack mount cabinets

SOFTWARE OPTIONS

- 68KFORTH¹ systems language with MACRO assembler and META compiler, Multi-user, Multi-Tasking
- Fast Floating Point package
- Motorola's MACSBUG
- IDRIS² Operating System with C, PASCAL, FORTRAN 77, 68K-BASIC¹, CIS COBOL⁴, RDBMS
- UNIX³ Sys III C, etc.
- CP/M-68K³ O/S with C, Assembler, 68K-BASIC¹, 68KFORTH¹, Z80 EMULATOR¹, APL
- VED68K¹ Screen Editor

Trademark 'ERG, Inc.

²BELL LABS ³Digital Research
⁴Micro Focus ¹Whitesmiths

30 day delivery
with valid Purchase Order

OEM prices available
For CPU, Integrated Card Sets
or Systems.



Empirical Research Group, Inc.
P.O. Box 1176
Milton, WA 98354
206-631-4855

RAM execute time in seconds

Incremental file size in bytes

Compiler Manufacturer	loops.c	control2.c	funcall1.c	intmath3.c	pointer1.c
c-systems	35.8	26.2	15.5	12.3	75.0
	128	512	256	640	128
Caprock Systems (1,2)	133.0	no goto: or case:	25.0	50.7	228.3
	256		384	1920	256
Computer Innovations	31.4	19.7	17.1	13.8	75.2
	84	388	212	612	100
DeSmet	19.9	13.4	10.9	11.6	41.7
	0	0	0	512	0
Intellect Associates (2)	56.8	no goto:	12.2	21.6	98.3
	128		256	371	128
Lattice	19.9	10.7	11.0	7.5	38.2
	0	256	128	256	0
Quantum	20.0	14.0	29.0	12.0	42.0
	74	295	263	510	88
Supersoft	47.0	26.0	12.2	26.3	108.3
	128	640	384	1792	256
Telecon	failed compilation	27.6	11.6	20.0	88.5
		512	256	1024	128

(1) 'puts' substituted for 'printf'
(2) 'while' loops in place of 'for' loops

Table 1: Code generation and execution times of the standard BYTE Sieve of Eratosthenes benchmark sieve.c and a floating-point benchmark (float.c) for those C compilers that support floating-point operations. Times are given in seconds for both the floppy disk and memory disk emulation modes.

faster development than coding from scratch in assembly language.

Are libraries standard and Unix compatible? Libraries of nonstandard functions may perform as well as or better than the standard functions on some specific machine, but when it comes time to move the code to another processor, the lack of standardization can prove expensive. Subtle differences in microprocessor libraries center around what a system call, in Unix, would directly or indirectly accomplish. Popular microprocessor operating systems require that subroutines simulate these calls.

In particular, the areas of file and byte-stream I/O (especially open and fopen) are subject to small variations in implementation to make up for the lack of capability in the surrounding operating system. (Table 3 on page 166 lists a full complement of standard, single-user functions.)

The c-systems compiler, which implements a nonfloating-point subset of C, does not yet allow cast operators or typedef declarations (although the developers expect to offer a fully standard implementation of C, including these abilities and floating point, by

FREE SHIPPING

PRINTERS

C. ITOH	
Prowriter 8510	\$345
F-10 Serial	\$1110
F-10 Parallel	\$1110

COMREX

CR-1-S	\$670
CR-1-P	\$760
CR-2	SAVE

DATASOUTH

DS-180	\$1170
--------------	--------

DIABLO

620RO	\$920
630RO	\$1720

IDS

Microprism 480	\$485
----------------------	-------

EPSON

RX80	SAVE
MX100	SAVE
FX80	SAVE

Free Cover with each Epson Printer

NEC

8023A	\$395
3510	\$1370
7710	\$2045

OKIDATA

82A	\$390
83A	\$635
84S	\$1070
84P	\$980

STAR MICRONICS

Gemini 10X&15X	SAVE
----------------------	------

TALLY

MT 160L w/ Tractors	\$570
MT 180L w/ Tractors	\$785

TEXAS INSTRUMENTS

810 Basic	\$1240
-----------------	--------

TOSHIBA

1350 Par or Ser	\$1475
-----------------------	--------

TELEVIDEO

910	\$570
910+	\$570
920	\$735
925	\$740
950	\$915
970	\$1025
803	\$1860

PIED PIPER

COMMUNICATOR I	\$999
----------------------	-------

Prices reflect 3% to 5% cash discount. Product shipped in factory cartons with manufacturer's warranty. Free shipping is on UPS ground only. Prices & availability subject to change without notice. Send cashier's check or money order...all other checks will delay shipping two weeks.

SILICON SPECIALTIES
2034 WEST SOUTHERN
MESA, ARIZONA 85202
602-969-0921

sieve.c Compiler Manufacturer	Compile Time		Link Time		Code Size File	Incremental	Execute in RAM
	Floppy	Memory	Floppy	Memory			
c-systems (3)	55	28.0	45	21	26368	15360	19.8
Caprock (1,2,3)	44	27.7	14.2	3.7	12800	8704	69.3
Computer Innovations	51	11.8	45	18.5	12864	234	17.4
DeSmet	41	3.8	40	4.6	6144	0	12.1
Intellect (1)	19	3.3	13	4.0	8704	8576	31.3
Lattice	33	7.2	40	10.5	19328	8320	11.3
Quantum (3)	39	8.0	42	14	11513	8384	12.6
Supersoft (3)	88	53.0	40.5	11.2	24960	8704	31.3
Telecon (3)	51	28.9	29	10.7	16256	8448	25.0

float.c Compiler Manufacturer	Compile Time		Link Time		File Size	RAM Library	Execution 8087
	Floppy	Memory	Floppy	Memory			
Computer Innovations	47.1	9.9	35	19.2	13052	805	45.3
DeSmet	41	4.7	39	4.9	6656	296	22.0
Lattice	34	5.2	41	10.3	12288	286	—
Quantum (3)	38	8	44	17	3367	—	13.0

(1) 'puts' substituted for 'printf'

(2) 'while' loops in place of 'for' loops

(3) compilation time includes assembly

Table 2: Incremental file sizes (factoring out the size of the library overhead) and execution times of some single benchmark functions.

August). The 60 library routines and macroinstructions supplied include useful, PC-specific, BIOS (basic input/output system) interface and video-display utilities, and the run-time package supports I/O redirection. As this article was written, the c-systems compiler and Digital Research C (for CP/M-86) were the only ones available that implemented multiple memory models, although others were imminent. The c-systems compiler, in addition to the usual small model, includes a command-line option and library for the medium model as well. Figure 1 il-

lustrates the variety of models available.

While not an outstanding performer in terms of code size, compile time, or execution time relative to others reviewed, the c-systems compiler's unique and innovative options make it a useful tool. Integer math and local-variable access benchmarks produced relatively efficient code, but performance lagged somewhat in control-mechanism efficiency testing. Function calling was burdened with the register variable mechanism, saving and restoring SI and DI registers on each call and return. Code-

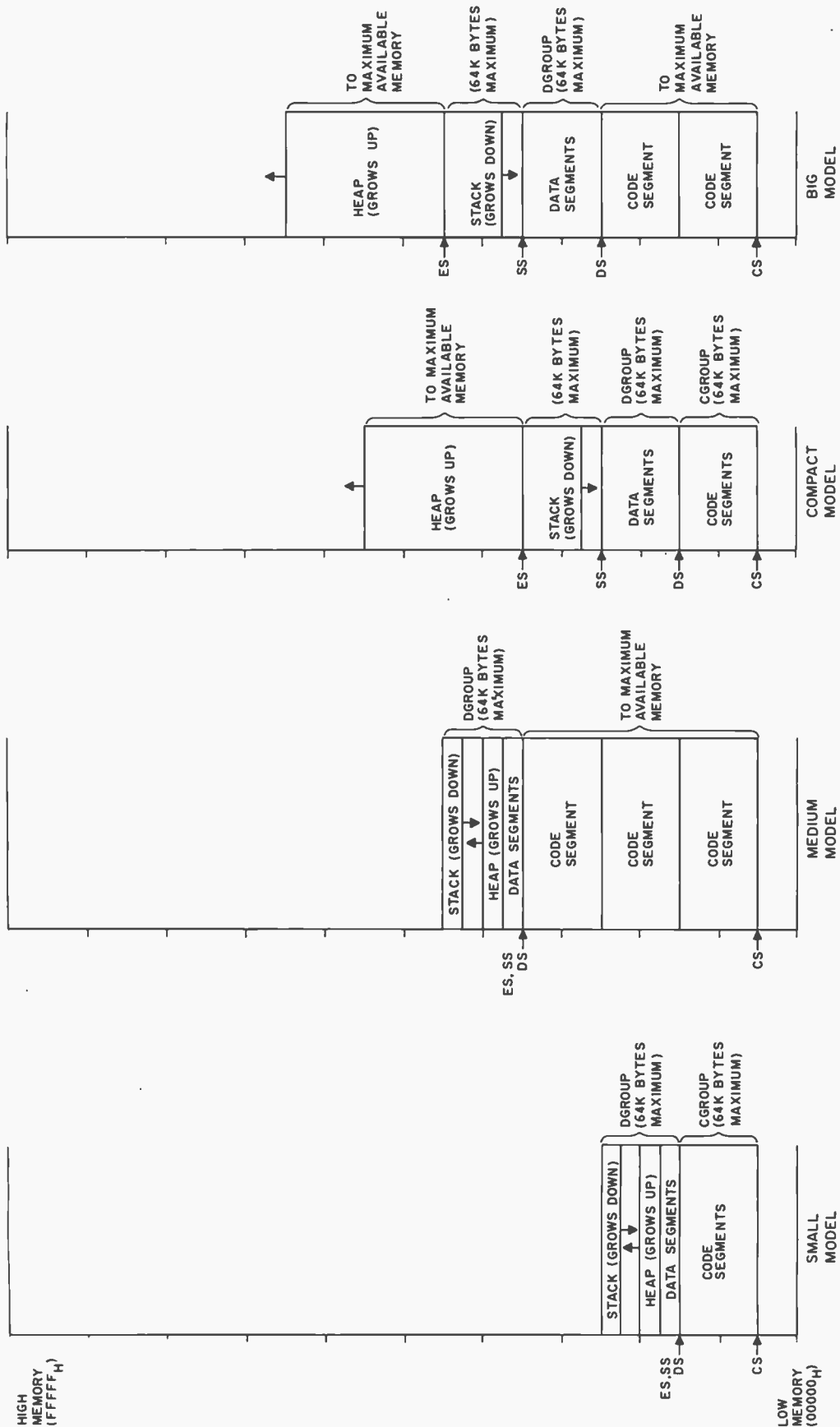

Figure 1: A diagram of the four memory models used by various C compilers.

Will this year's bells and whistles be next year's hoots and howls?

NOT IF IT'S A GIFFORD.

Freedom from obsolescence now costs less than \$10,000 for 3 users. Because Gifford Multi-User Computer Systems, based on industry standard IEEE 696/S-100 with 20 bus slots, allow ample expandability and upgradability as new processors and peripherals are introduced. For example, up to four additional users can be added for only \$600 each, plus terminal costs. All while protecting your investment.

That's why Gifford computer systems, with their dual processor CompuPro CPUs, have proven themselves to be THE

SYSTEM for business and technical professionals requiring obsolescence-proof, hard-disk computers.

GIFFORD GIVES YOU THE BEST OF TWO SOFTWARE WORLDS.

We were the first company to develop a system that runs any combination of 8 and 16 bit CP/M™ programs simultaneously. So, if you go with Gifford, you'll *know* you can use the thousands of 8 bit CP/M programs available, PLUS any of the more powerful 16 bit programs ... at the same time.

And, in addition to compatibility with all the CP/M software that's out there, you also get Super-Calc-86™, dBase II™ and MP/M-86™ FREE.

PRICELESS INFORMATION FOR THE PRICE OF A STAMP.

We invite you to cut out the coupon and mail it to us today. We'll send you a free brochure with detailed information regarding all the other advantages of going with Gifford. Such as, our exclusive networking and multi-tasking telecommunications packages, our two year warranty, complete service and support, system integration and custom application software. Plus all the benefits of selecting an IEEE 696/S-100 bus-based system.

MP/M-8-16 is a proprietary implementation of MP/M-86 and was configured for CompuPro by Gifford Computer Systems. CP/M and MP/M are registered trademarks of Digital Research. Super-Calc is a trademark of Sorcim. dBase II is a trademark of Ashton-Tate. CompuPro is a trademark of Godbout Electronics. Prices and specifications subject to change.



GIFFORD
COMPUTER SYSTEMS

1922 Republic Avenue, San Leandro, CA 94577
(415) 895-0798 A division of G&G Engineering
I'D LIKE THE WHOLE STORY.
Please send me your brochure.

Name _____ Title _____

Organization _____ M/S _____

Address _____

City _____ State _____ Zip _____

Phone _____

Please have a representative call me.

Other centers opening soon nationwide.

GIFFORD COMPUTER SYSTEMS SAN LEANDRO, CA (415) 895-0798 SAN FRANCISCO, CA (415) 391-4570 LOS ANGELES, CA (213) 477-3921
 MIAMI, FL (305) 665-9212 HOUSTON, TX (713) 877-1212 AMHERST, NY (716) 833-4758

Memory Models

A thorough understanding of the models employed to structure memory usage beyond the familiar 8-bit processor, 64K-byte domain is necessary. The revolutionary innovations in software design will not come from using this newly available memory resource for more spreadsheet arrays or a bigger memory disk emulator. Real innovation and creative design can only progress when the tools are available for concrete realizations.

Two compiler manufacturers (c-systems and Digital Research) are already supporting larger memory usage, one has two additional memory models in test sites (Lattice), and at least two others (Mark Williams and Mark DeSmet) have definite plans for supporting larger models in the near future. The tools are here; we need to know how they work.

Although the Intel 8088 microprocessor used by the IBM Personal Computer can directly address over one million bytes of semiconductor memory, the manner in which this space is accessed leads to compromises in both hardware and software architectures. For the processor to retain a 16-bit internal datapath (assuring relative

ease in software migration from earlier Intel products), a segmented architecture was chosen.

To generate the 20-bit physical address needed to reach any location in the memory space, the bus-interface unit of the processor automatically shifts the 16-bit contents of one of the four segment registers left by four binary bits (filling the spaces created on the right with binary zeros) and internally adds this result to a 16-bit register containing an offset address. Therefore, to reach any memory with a physical address outside a 64K-byte span, the appropriate segment register must be adjusted. The processor takes fewer clock cycles to operate within a 64K-byte logical address space and requires additional cycles for any memory transactions outside that limit. The compiler designer wishing to enable access to code or data spaces beyond 64K bytes faces a confusing thicket of tradeoffs as a result of this complex process.

To deal with this complexity, C compiler writers for Intel's 16-bit architecture are choosing to adapt the four memory models expressed in the Intel PL/M-86 object format (see figure 1). The most widely used

model, and the default model for most compilers, is the small memory model, which defines separate code and data areas, with a maximum size of 64K bytes each for a total program memory access to 128K bytes. All code must fit within the code group; the 8088 CS register is used as relative origin. All data and the stack must fit within another 64K-byte area with the DS, ES, and SS registers all pointing to its origin and defining the lowest accessible address. Within this data area the stack grows downward from the highest available data memory, and the dynamically allocated heap area, generally based on the 8088's ES register, grows upward from the top of whatever memory the compiler has allocated as a fixed area for globally available variables and data.

The medium model still restricts its programs to a maximum of 64K bytes of data, apportioned identically to the small model, but code is allowed to expand to the limit of maximum available memory. The compiler and linker normally manage the CS segment register to generate the optimally appropriate form of call and return. A third model, the compact model, limits code and

production times were impeded by the use of the snail-like PC assembler. Sieve execution performance improved by 22 percent when register variables were used for the loop indexes.

The company's c-window symbolic debugging package, available for \$195, is a unique and valuable option worth noting. When the user sets a compiler command-line option (the debugger works only with the c-systems compiler), provision is made to link a separate library containing a program-execution supervisor. When the compiled program is run, high-level debugging using single-step, trace, or breakpoint is supported with breaks conditional on count, function name, and source-line number or by nonzero evaluation of arbitrarily complex user-defined expressions. Extensive user-specified automatic commands allow the setting or display of evaluated expressions, variables, and data with radices and formats precisely predetermined.

Another interesting command-line

option allows the user to set a PL/M- and Pascal-compatible argument-passing convention. Compared to C, arguments are placed on, and removed from, the stack in inverse order. Because C allows a variable number of arguments to be passed into a function, all arguments must be explicitly declared when the function is declared, enabling the compiler to generate proper stack cleanup on function returns. This option can be used to compile C function modules callable from Pascal or PL/M programs and, when combined with the medium memory model, to generate code for popular real-time operating systems such as Intel's RMX-86 or Industrial Programming's MTOS-86.

The documentation explains these complex options and contains a full treatment of the assembly-language interface to c-systems code. However, while the 46-page manual is accurate, complete, and useful, it includes neither an index nor error message explanations. An alphabetic reference

list of the library functions would be a welcome addition.

Caprock small-c is a result of Ron Cain's generosity (i.e., it is a translation of source code intended for the 8080, originally published in *Dr. Dobbs' Journal* #45 and placed in the public domain by Cain at that time). Program run-time memory usage is organized by assigning all code to a 64K-byte code segment shared, after linkage, with the run-time library. The stack, which manages all data items, has a separate 64K-byte segment. The PC-DOS linker assigns the code segment to low memory, with the stack segment immediately above.

Assembly language provides for any desired departures from the above arrangement, as long as you assume responsibility for juggling the segments. In contrast to the original small-c, the compiler can produce multiple output files and supports true extern linkage, so the entire run-time library source is not required as

external variables to 64K bytes each and allots a full 64K bytes for stack data, with the CS, DS, and SS registers adjusted accordingly. The heap data area employs the ES register, growing upward, and can occupy up to all of the remaining memory. The amount of memory allotted to heap use is generally specified at link time.

The final model, the big model, is a deviation from the PL/M-86 convention's large model plan. In the PL/M-86 model, each code segment allocation should be able to access its own 64K-byte data segment. C compiler writers have settled on a less ambitious scheme, where a program is limited to a single 64K-byte data space for global data, a single 64K-byte stack area, but allowing code and heap allocations to divide up the remaining memory with the heap left to manage whatever is not used by the program code.

In the words of its progenitors, "C is not a 'very high-level' language." A programmer can get close to and manipulate the details of individual machines. Therefore, a few ramifications to all of the above exist that govern C compiler design and should influence the C programmer's choices and

coding practices. Under the small model, the natural integer size and natural pointer size for C are both 16 bits, a fact that allows maximum efficiency in using the 8088 processor and a minimum of confusion for the programmer. In the big model, the natural size for C int and pointer types is 32 bits, and while the processor takes longer to juggle 32 bits than 16, this concerns the programmer solely from a code size and performance standpoint.

With the compact and medium models, care must be exercised. In the compact model all function calls are short (16 bits), but the dynamic data must be managed in C using 32-bit data pointers, loads, and stores. Thus char pointer and natural integers are not all the same size, and care should be exercised in the use of casts and type conversions. The medium model, which allows long calls but restricts all stack and data to 64K bytes, reverses the implications of the previous anomaly if you want to use pointers to functions or manipulate code addresses directly.

compiler input along with the user's program. The assembly-language interface is adequately documented and is aided by the directives #asm and #endasm for including in-line assembly statements in the C source file.

While quite inexpensive, the Caprock small-c lacks many of the features that make C the powerful systems tool it is. For instance, the control structures while, for, switch, and goto are missing. This subset does not support the storage classes auto, static, and register; typedef declarations; float or long int data types; conditional compilation (#ifdef, etc.); arguments for #define preprocessor statements, initializers on declaration or casts; and multidimensional arrays, structures, and unions are not allowed. Functions may only return int, pointers may only point to char or int, and no complex assignments are permitted. Caprock small-c does not support conditional expressions, comma, logical negation, and one's complement.

In performance, small-c came in last in every test of execution speed and behind most of the others in code size and compile time. The interactive nature of the command mode is inoffensive, but assembly durations require patience.

Why, then, is such software useful? First, as the least expensive C compiler available for the PC, it can give the programmer a taste of the language without a large cash investment. Beginners at programming should know, however, that using small-c as a means to learn programming or to learn C can be extremely frustrating at best because so much of the language is absent. Most programs from books or magazines will simply not compile or run without significant alteration. Such changes are best left to the experienced.

Caprock small-c could also be used as a learning aid for the C programmer. The source code for the entire compiler and run-time library is included on the disk; it is a unique aid for anyone interested in studying and

tinkering with the mechanics of compiler construction. And because the disk includes a translation, into C source, of the text-formatting program from Kernighan and Plauger's classic text, *Software Tools*, it is a valuable resource for the student learning how to translate into C from another language (RATFOR preprocessed FORTRAN or Pascal, depending on which version of the book you use). As a bonus, the executable version provides some useful word-processing capabilities when combined with a trusty text editor.

Computer Innovations C86: In addition to the three-pass compiler and complete source-code files for the assembly language and C library functions, this package includes an object-code librarian, object libraries, a linker, and a source-code library-maintenance program that allows many small code files to be stored in one archive, eliminating disk-file clutter and freeing disk-directory entries.

The CI-C86 compiler accepts the standard C language and produces object code in a format exclusive to the system linker. Register variable declarations are converted to auto (storage class), and true register variables are slated for a future release. A command-line option allows 31 character identifiers, a feature that increases the self-documenting qualities of the resulting code but makes it more difficult to transport. Other compiler options enable comments to nest and permit the entry of command-line #defines. Error messages are accompanied by the line number the compiler was working on when the error was detected. An interim solution to interfacing assembly-language to a nonstandard object-module environment is provided by a program that converts an assembler's output to a form acceptable to the CI-C86 linker.

Although only the small memory model is implemented, the package includes a software foundation for using overlays. Library routines enable program I/O redirection. The 8087 math coprocessor is supported by calls to library functions, and in-line code capability is scheduled for

Text continued on page 146

ALPHA OMEGA

COMPUTER PRODUCTS

ALPHA OMEGA COMPUTER PRODUCTS. The beginning of fast, efficient service and low-priced computer products. The end of mail order worries!

We have a reputation for excellent service and low prices and at ALPHA OMEGA we enjoy living up to that reputation.

DISKETTES

SCOTCH 3M SS DD 24.95
MAXELL MD2 DD DD 41.00

PRINTERS

CITOH 8510 PARALLEL 385.00
GEMINI 10 325.00
GEMINI 15 490.00
OKIDATA MICROLINE 92 529.00
OKIDATA MICROLINE 93 914.00
EPSON FX-80 \$CALLS

MODEMS

HAYES SMARTMODEM 300 209.00
HAYES SMARTMODEM 1200 524.95
HAYES MICROMODEM II 279.00

MONITORS

USI P1 3 12" AMBER 159.00
NEC JB 1201M 12" GREEN 159.00
TAXAN 12" AMBER 129.95
AMDEK COLOR I 13" 285.00
AMDEK COLOR II 13" RGB 425.00

IBM PERIPHERALS & SOFTWARE

TANDON TM55-2 THIN LINE \$CALLS
TANDON TM100-2 259.00
AMDISK III 3" DISK SYS 690.00
VISTA MULTICARD \$CALLS
KRAFT & T.G. JOYSTICKS 46.95
DBASE II 425.00
WORDSTAR 269.00
HOME ACCOUNTANT + 99.00
VOLKSWRITER 140.00
LOTUS 1.2.3 \$CALLS
MULTIPLAN 185.00

APPLE PERIPHERALS & SOFTWARE

VIDEX VIDEOTERM 80 COLUMN.. 219.00
MICROSOFT PREMIUM PAK 474.95
MICROSOFT 16K RAMCARD 69.00
KRAFT & T.G. JOYSTICKS 45.95
OUENTIN APPELMATE DRIVES... 245.00
SUPER 5 THIN LINE DRIVES 275.00
WIZARD BPO16K BUFFERED INT. 139.95
PFS FILING SYSTEM 85.00
PFS REPORT 67.00
DBASE II 425.00
WORDSTAR 269.00

THESE ARE SAMPLES OF THE MANY PRODUCTS THAT ARE AVAILABLE. PLEASE CALL FOR PRICING AND INFORMATION.

(213) **345-4422**



4847 LA MONTANA CIRCLE
TARZANA, CA 91356

All products are in factory sealed packages. We guarantee all items for 30 days. Within this period, defective merchandise returns must be accompanied by RMA number. All other returns will be subject to a 10% restocking fee. For prepaid orders there will be a 3% shipping charge, \$5.00 minimum. There will be an additional \$4.00 surcharge on COD orders. Cash or Cashiers Check is required on COD orders. Calif. residents add 6.5% sales tax. Prices subject to change without notice.

Listing 1: The math benchmark.

```
/*      intmath3.c      */

#define COUNT 10000

main( )
(
    int i, j, k;
    printf("Starting\n");
    for(i = 0; i < COUNT; ++i) {
        j = 240; k = 15;

/* test byte-byte combinations */
        j = (k * ( j / k ));
        j = (k * ( j / k ));
        j = ( k+k+k+k+ k+k+k+k+ k+k+k+k+ k+k+k+k );
        k = (j -k-k-k-k -k-k-k-k -k-k-k-k -k-k-k );

/* test byte-word combinations */
        j = (j << 4); k = (k << 4);
        j = (k * ( j / k ));
        j = (k * ( j / k ));
        j = ( k+k+k+k+ k+k+k+k+ k+k+k+k+ k+k+k+k );
        k = (j -k-k-k-k -k-k-k-k -k-k-k-k -k-k-k );

/* test word-word combinations */
        j = (j << 4); k = (k << 4);
        j = (k * ( j / k ));
        j = (k * ( j / k ));
        j = ( k+k+k+k+ k+k+k+k+ k+k+k+k+ k+k+k+k );
        k = (j -k-k-k-k -k-k-k-k -k-k-k-k -k-k-k );
    }
    printf("Finished\n");
}
/*      intmath3.c      end      */
```

Listing 2: The pointer benchmark.

```
/*      pointer1.c      */

#define COUNT 10000
#define ALLOTTED 128

main( )
(
    char workarea[ALLOTTED], *ptr;
    int i;
    printf("Starting\n");
    for(i=0; i < COUNT; ++i) {
        ptr = workarea;
        while(ptr < (workarea + ALLOTTED)) {
            *ptr = ' ';
            ++ptr;
        }
    }
    printf("Finished\n");
}
/*      pointer1.c      end      */
```

TIME-PROVEN PERFORMANCE



Now Available Nationwide
Through Participating
COMPUTERLAND Stores

While new printers with impressive specifications are introduced on an almost daily basis, only time will tell the true quality of the product. Over the past 2 years our customers have continued to buy the DS180 printer, not only because of its impressive performance and competitive price, but also because of our outstanding track record for product reliability and customer support.

We have continually improved on the performance of the DS180 by incorporating such enhancements as dot addressable graphics, 6 user-selectable print sizes and a 2000 character buffer. These features coupled with 180 cps printing, parallel and serial interfaces, adjustable tractor feed and over 40 other programmable features, make the DS180 one of the most versatile matrix printers available today.

Before you select your next printer, why not take a look at a time-proven performer—the Datasouth DS180.

The DS180 printer is available nationwide through our network of sales/service distributors.

datasouth computer corporation

P.O. Box 240947 • Charlotte, NC 28224 • 704/523-8500

Telex: 6843018 DASOU UW

www.americanradiohistory.com

Circle 131 on Inquiry card.



Construction Costs Profile

- A - Materials (24%)
- B - Labor (31%)
- C - Overhead (23%)
- D - Land (22%)

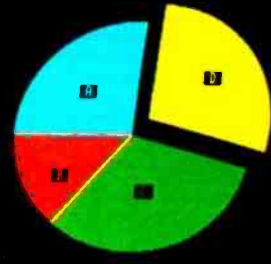

Only Texas Instruments offers these 7 advantages that add up to more computer for your money.

If you're a smart business professional, you want a business computer that gives you the most productivity power for your dollar. For you, Texas Instruments has the answer: the TI Professional Computer. With seven obvious advantages that make buying TI make sense.

The Disk Storage Advantage.

The TI Professional Computer gives you standard 320K floppy disk storage. That's twice the standard data storage of the leading competitor.

The Function Key Advantage.

We give you 12 function keys that you can easily preprogram to make your work simpler and easier. The best the competition can do is 10 or fewer function keys.

The Keyboard Advantage.

Our standard touch-typing layout makes word processing as easy as sitting at a typewriter. The separate numeric and cursor control keypads let you isolate information and enter numbers for spreadsheets more quickly. And with our isolated edit/delete keys, you'll never have to

worry about accidentally erasing valuable data.

The Monitor Advantage.

Our monitor gives you 40-50% better resolution than the leading personal computers. Which means you get clearer displays that are easy on the eyes. And some of the sharpest graphics possible today.

The Software Advantage.

There's software available now for the TI Professional Computer that meets virtually every professional and small business need. And with our memory expansion board, you can use advanced integrated software like Lotus 1-2-3™ to help you do several kinds of work without changing programs.

The Expandability Advantage.

Our standard features like the floppy disk controller and printer support are built-in so they don't take up the valuable expansion slots you'll need for adding optional features like communications and up to ten megabytes of hard-disk storage. Which leads to one of our most exciting advantages...

The Future Enhancement Advantage.

No one wants to buy a personal computer that's already on the road to obsolescence. That's why we're developing exciting new features that you can easily add to your TI Professional Computer—like speech recognition. Imagine being able to say, "Spreadsheet, please" and having it appear instantly on your monitor. This and more will be available this fall.

One additional benefit makes the TI Professional Computer especially attractive — the price. Feature for feature, dollar for dollar, you'll choose TI.

Get the business computer that puts these benefits to your advantage. Visit your TI authorized dealer or write: Texas Instruments Data Systems Group CA, Dept. 062BY, P. O. Box 402430, Dallas, TX 75240. Or call toll-free: 1-800-527-3500.



TEXAS INSTRUMENTS

Creating useful products
and services for you.

VICTORY AT C.

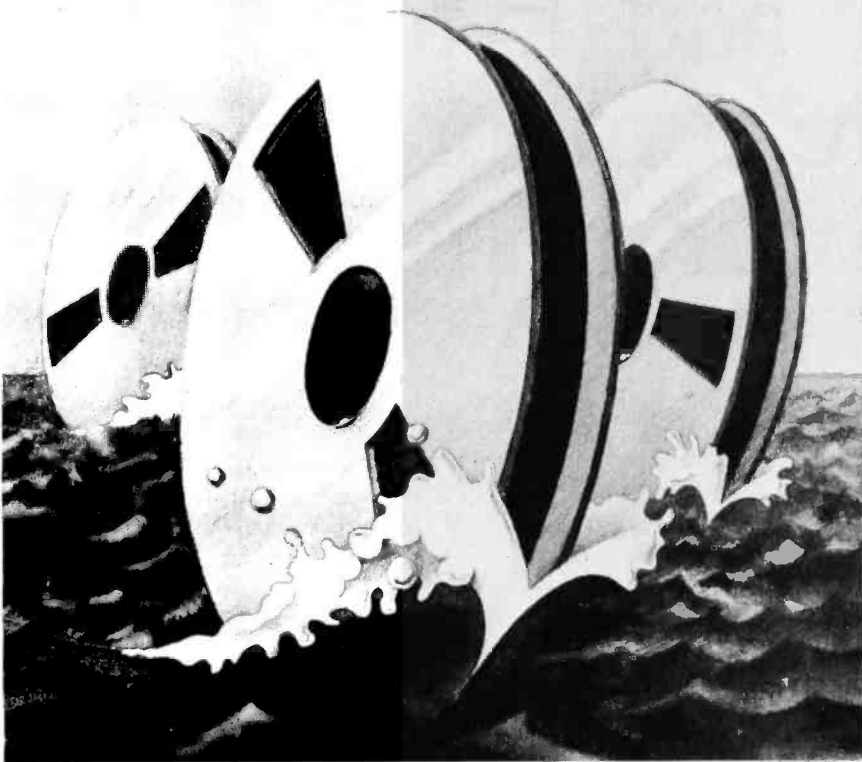

The Z-80 C Cross-Compiler Fleet has arrived.

Is your Z-80 C object code larger than it needs to be? Rerouting to assembler because C isn't fulfilling its promise? Your ship has come in. Vandara introduces the Z-80 C Cross-Compiler. Starting with the finest "pure" C-to-8080 cross-compiler available (Whiresmiths), we've added 8-bit expressions, a right calling convention, a peephole optimizer and full use of the Z-80 instruction set to reduce your code size by up to 36%.

And if you're in a ROM-based environment, you'll appreciate our in-line machine code, listings, ROM-able tables and optional royalty-free runtime library!

The Vandara Z-80 C Cross-Compiler is available for VAX, PDP-11, 68000 and Z8000 hosts.

For more information call (206) 542-7611 or write VANDARA 17544 Midvale Ave. N., Suite 107 Seattle, WA 98133 Call toll free: 1-800-426-5248



Text continued from page 141:

future release.

More than 100 library subroutines include several utilities for math, memory management, and string manipulation. Two important library functions behave differently with respect to the standard, so migrant code may need adjustment: the CI-C86 I/O subroutine `fopen` employs a 12-choice mode argument, rather than the usual 3-choice mode, to accommodate CP/M end-of-file conventions and to differentiate between binary and ASCII files. The CI-C86 open system-call simulation requires a 6-choice mode for similar reasons. The formatted I/O functions include the nonstandard, but welcome, extension of capability in the inclusion of a binary radix.

The manual's coverage of this particular implementation of C is a bit thin. The individual programs included are documented in clearly structured style, but error messages are neither listed nor explained, and the descriptions of the programs and routines are often terse. The alphabetic listing and clear one-to-a-page format of library-routine documentation, however, make for easy reference.

This widely used compiler has been the subject of continual work and improvement since its introduction, and it will probably continue to improve. C86 was relatively inefficient at function calling, a drawback unrelated to overhead of register variables because the register type is converted to auto. Code generated for integer math and local-variable access was relatively efficient compared to others.

In use, C86 is simple and straightforward and complicated only by the need to manage the nonstandard linker's syntax. Error messages can be confusing if they don't offer additional documentation, but a provision to print a source listing after the preprocessing pass can be a useful debugging tool. By including source code for the run-time subroutine library, Computer Innovations gives the user greater control over the structure of the final executable code module. While I found no real basis for complaint about this product,

\$\$ "LOWEST PRICES" \$\$



SMITH CORONA

LETTER QUALITY PRINTERS

SMITH CORONA TP1 June Special \$514
Less June & July Mfg. Rebate 50
ONLY \$464
STARWRITER 40 CPS S or P . . . \$1274
PRINTMASTER 55 CPS S or P . . . 1544
NEC 3510 33 CPS SERIAL 1386

DOT MATRIX PRINTERS

GORILLA BANANA Graphics \$221
EPSON
MX-80 w/Graphics Rom+ 80 cps . . 427
FX-80 Friction & Tractor 160cps . . 595
MX-100 Friction & Tract. 100cps . . 653
STAR MICRONICS
GEMINI 10 2.3K Buffer 100 cps . . 329
GEMINI 15 15" Carriage 494
OKIDATA
82A Serial & Parallel 120 cps . . . 404
84 Parallel 15" Fr&Tr 200 cps . . . 960
92 Parallel 10" Fr&Tr 160 cps . . . 501
PROWRITER 8510 10"Par 120cps 404
8600-Near Letter Quality Par . . . 1031
PRISM 80 756

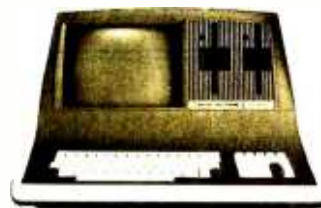

SUPERBRAIN

SUPERBRAIN II

DOUBLE DENSITY \$1970
QUAD DENSITY 2376
SUPER DENSITY 2684

COMPUSTARS FOR NETWORKING

VPU-10 \$1540
VPU-20 2284
VPU-30 2656
VPU-40 3029
DSS-10 3029

AMERICAN SQUARE COMPUTERS is organizing a World Wide Association of Computer Dealers. Open a Store or Start Work Out of Your Home! We Charge NO FRANCHISE FEE! (Our Competitors charge a FRANCHISE FEE of from \$15,000.00 to \$45,000.00.) Be a Winner! Let US help YOU get started MAKING MONEY by HELPING PEOPLE to put COMPUTERS to WORK. Write or Phone today.

Which Computers are Best? . . . Free
Insured Shipping at Low Rates.

ADVANCED DIGITAL

S-100 SUPER QUAD SINGLE BOARD
COMPUTER Z-80 64K RS232 DISK
CONTROLLER FOR 5" OR 8" . . . \$474
SUPER SLAVE 128K + PS NET/1 . . . 437
SUPER SIX/128 6 MHZ 128K 555
TURBODOS SINGLE USER 250
SUPER SYSTEM-DD-8 2327
SUPER SYSTEM-8-HD-10 3920

ALTOS COMPUTERS

8000-2 64K RAM \$2680
8000-15 208K RAM 3653
8000-10 208K RAM 5571
5-15D 3 USER 2 5 1/4" 2201
5-5D 3 USER HARD DISK 4379
8600-12 16 BIT 20 MB HD 9104

COMMODORE 64

CALL
ATARI 400 w/Rebate Coupon . . . \$149
ATARI 800 655

TRAXX 5 1/4" ADD ON DRIVES

Bare drive SSDD Quantity 2 Ea . . . 215
SSDD w/cabinet & power sup. . . . 312



TELEVIDEO

TERMINALS

TELEVIDEO 910 OR 910+ \$538
TELEVIDEO 925 Detach Keybd . . . 674
TELEVIDEO 950 Prog func keys . . . 863
TELEVIDEO 970 VT-100 compat . . . 935
ADDS Viewpoint 3A+ Emulates . . . 458
ADDS Viewpoint 60 Graphics 620
ADDS Viewpoint 90 Prog. EPROM 820
ADDS Color Terminal NEW! 998
Zenith Z-29 Z19&VT100 compat . . . 655
Zenith ZT-1 Terminal+modem . . . 460
Visual 50 Ergonomic \$545
Visual 55 New! Enhanced #50 626
Visual 100 80/132 columns 890
Visual 200 Tilts&detach keybd . . . 761
Visual 330 VT52&Haz1500 comp . . . 782
Visual 400 ANSI x3.64 compat . . . 1074
Visual 500 Graphics 14" screen . . . 1646

MONITORS

ZENITH
ZVM 121 Green Phosphor \$123
ZVM RGB Color Monitor 545
GDZ-13-14 Composite Color 325

NEC

JC1201M 12" Composite Color \$378
JC1202DHA 12" RGB Color Mon. 810
JB1201M 12" Green phosphor . . . 176

AMDEK

Color I Color monitor \$321
300G 12" Green 165

GRAPHICS & COLOR GRAPHICS

VECTRIX

VX 128 8 colors 322x560 Pix. . . . \$2245
VX 384 16.8 million colors 3865
VXM Hi Res. 13" RGB Monitor . . . 1430

MICROANGELO

MA 512 512x480 Monochrome . . \$674
MA 520 512x480 + Screen Pak2 . . 890

COMPUTERS

COMPUPRO

Compupro computers come as main-
frame, boards, and drives, and you just
set the switches.

816A Computer 8085/8088 128K \$3964
816B Computer 8085/8088 256K 5038
816C 8085/8088 384K 3 users . . . 6470
816D 10 MHz 8086 512K 10052
816-08 CPUZ 208K Oasis 6471
816-016 10 MHZ 8086 512K 10052

SEATTLE Pure 16 bit computer is the

fastest microcomputer by actual test!
S-100, 128K Static Ram, 8 MHz 8086 18
slot, Mainframe, 3 serial & 1 parallel
ports.

Gazelle II computer \$4346
Hard Disk Gazelle II 5750

RADIO SHACK TRS-80 SAVE! CALL

TARBELL with 2-8" disk drives
EMPIRE I single sided \$3304
EMPIRE II double sided 3775

MEDICAL SOFTWARE

MICROMED & MICRODENT . . . 1656
STARDOC 350
THE DOCTOR'S OFFICE NEW! CALL



NORTH STAR ADVANTAGE

North Star Advantage	8 BIT	8/16
Work Station	\$1918	\$2281
2 Floppies 360K ea. . . .	2252	2542
5 Mb Hard + 360K Floppy	3362	3652
15 Mb Hard + 360K Floppy	4385	4748

NORTH STAR HORIZON

HORIZON	1 User	Multi
2 Floppies 360K ea. . . .	\$2252	N/A
5 Mb Hard + Floppy	3362	\$6095
15 Mb Hard + Floppy	4385	6821
18 Mb Hard + Floppy	5837	8273



Morrow
Terminal

Micro Decision II

MICRO DECISION

"A DEAL YOU CAN'T REFUSE"

64K RAM Z80 4MHz 2 serial ports
5 1/4" disks Free Software — CPM 2.2
MicroSoft Basic, BaZic, WordStar
LogiCalc spreadsheet, Correct-it

ONLY
MD1 1 single sided 5 1/4" \$818
MD1 +ADDS 3A+ Terminal 1269
MD1 +ADDS 3A+ +Smith Corona 1769

MD2 2-5" SS drvs + Per. Pearl . . . 1148
MD2 +ADDS 3A+ Terminal 1599
MD2 +ADDS 3A+ +Smith Corona 2099

MD3 2 sided drives & Bookkeeping
& Personal Pearl. FANTASTIC BUY

MD3 2 Double sided drives 1566
MD3 +ADDS 3A+ Terminal 2019
MD3 +ADDS 3A+ +Smith Corona 2519

Above Packages include all Cables

DECISION I

"IBM-360 on the Z-80 & S-100 Bus!"

Sixteen programs running simultane-
ously! FREE CPM, MicroSoft Basic,
S-100, IEEE 696, 14-slot, 4 MHz Z80
Real time clock, Interrupts, 3 Serial
& 1 parallel port, 64K static RAM ex-
pandable to 1 Megabyte.

D1 Hardware & Software as above \$1712
D2 Has 2 DSSD 5 1/4" drives . . . 2485
D3A 1 DSSD 5 1/4" +5 Mb Hard Disk
+Wordstar, Correct-It, LogiCalc,
BaZic, and Personal Pearl

D3A w/5 Mb Hard Disk 3120
D3C w/15 Mb Hard Disk 3822

MOS Multi user upgrade 3-64K RAMS
+Micronix operating system 1432

MOS+ with above & Whitesmith's C
& Pascal 1783

MORROW DISK DRIVES

Complete systems include S-100 con-
troller, power supply, cabinet, & fan,
CPM & Basic 80.

Add Drives include power supply, cabi-
net & fan.

	System	Drive
5 1/4" Winchester	5Mb	\$1572 \$1151
5 1/4" Winchester	15Mb	2485 2064
8" Winchester	10Mb	2625 2134
8" Winchester	20Mb	3187 2766
14" Winchester	26Mb	3187 2766

	8" (w/DMA controller)	
One 1 sided	\$870	\$576
One 2 sided	1081	800
Two 1 sided	1418	1011
Two 2 sided	1839	1432

Call for latest prices & availability

Factory Guarantees

We Beat Prices

AMERICAN



COMPUTERS

919-889-4577

4167 Kivett Dr.

Jamestown N.C. 27282

919-883-1105

Circle 22 on Inquiry card.

BYTE August 1983 147

Name

DeSmet C Development Package version 1.5

Type of Software Package

C programming language compiler

Manufacturer

C Ware
1607 New Brunswick Ave.
Sunnyvale, CA 94087
(408) 736-6905

Price

\$100

Format

5¼-inch double-density single-sided IBM PC-compatible PC-DOS or CP/M-86 format floppy disks

Type of Compiler

Produces object code or assembly language

Computer Needed

IBM PC running PC-DOS or CP/M-86 with two single-sided disk drives and a minimum of 64K bytes of RAM

Documentation

105-page loose-leaf manual

Audience

Systems and applications software developers, C programmers

Name

C88 version 2.01

Type of Software Package

C programming language compiler

Manufacturer

Intellect Associates Inc.
POB 365
Holbrook, NY 11741
(516) 472-4449

Price

\$150

Format

5¼-inch double-density single-sided IBM PC-compatible PC-DOS format floppy disks

Type of Compiler

Produces object code

Computer Needed

IBM PC running PC-DOS with two single-sided disk drives and a minimum of 64K bytes of RAM

Documentation

60-page staple-bound manual

Audience

System and applications software developers, C programmers

Name

Lattice C version 1.04

Type of Software Package

C programming language compiler

Manufacturer

Lattice Inc.
POB 648
Hoffman Estates, IL 60195
(312) 843-2405

Price

\$500

Format

5¼-inch double-density single-sided IBM PC-compatible PC-DOS or CP/M-86 format floppy disks

Type of Compiler

Produces object code

Computer Needed:

IBM PC running PC-DOS or CP/M-86 with two single-sided disk drives and a minimum of 128K bytes of RAM

Documentation

162-page staple-bound loose-leaf manual

Audience

Systems and applications software developers, C programmers

neither its features nor its performance were relatively outstanding.

Mark DeSmet has recently released a full suite of 8088 systems-development software accompanied by more than 100 pages of documentation. Available from C-Ware for the low price of \$100, the package includes a two-pass compiler, screen editor, assembler, linker loader, cross-reference and list utility, object-code librarian, and two valuable system-utility programs in both source code and executable form. The run-time library is supplied in two versions; one provides 8087 coprocessor floating-point support, and the other provides software floating-point subroutines.

The extent and quality of these programs are amazing. The DeSmet compiler was usually fastest in compilation and linkage times, regularly produced tight code and small incremental program size, and always ranked at the top in terms of execu-

tion speed. Because it is relatively young, the product is bound to have some rough edges. For instance, the preprocessor section of version 1.5 failed to properly handle tests of intricate #define expansion, producing spurious code with no compile-time error indication. In all other tests run, no further fault was found with compiler accuracy.

This system produced consistent optimization in both code size and execution speed and generated code that consistently outperformed all but the Lattice compiler. In the short history of this product, C-ware seems committed to continuously improving it and has already added substantially to the library. The DeSmet package is an unsurpassed vehicle for programmers in other languages (particularly assembler) to use in learning C. Examples of C and assembly-language source files that are included deftly illustrate the range of capabilities available.

Although it does not support Unix

version 7 extensions, in most other respects the DeSmet compiler accepts the entire standard C syntax, including all widely used data types and operators. For example, the only pre-Unix version 7 data type missing is short, which may be added by employing typedef. Extensions are made to support 31-character variable names (for more readable code) and to include assembly language in line via the #asm preprocessor directive. Console I/O is not provided with redirection in the current release, and only the small memory model is presently supported.

A full-facility programmer's tool, the screen editor has an elegantly simple command syntax. The assembler includes all 8087 coprocessor mnemonics and uses a syntax that differs only slightly from that of Intel's ASM-86 standard. Bind, the system's linking loader, is used to produce executable files from the object output of both the assembler and the compiler. It produces a full sorted

IBM® AUGUST PRICE WAR!

These sale prices good through August 31, 1983.

WordStar® \$249	dBASE II™ \$439	Lotus™ 1/2/3 \$379	SuperCalc™ \$129	Multiplan™ \$189
WordStar® MailMerge™ \$349	InfoStar™ \$259	WordStar® dBASE II™ \$679	VisiCalc® \$169	Perfect Writer™ \$289

ALPHA SOFTWARE™ All Products CALL	dGraph \$219	SuperSort \$129	Perfect Writer/Speller \$409
APPLIED SOFTWARE TECHNOLOGY™ VersaForm \$269	HAYES™ SmartModem \$549	SpellStar \$129	Perfect Calc \$169
ASHTON-TATE™ dBase II \$439	HOWARDISOFT™ All Products CALL	ReportStar \$219	Perfect Filer \$279
ASPEN SOFTWARE™ Grammatik \$ 60	IUS™ EasyWriter II \$189	Apple Packages and Other Specials CALL	All Four Perfect Products \$799
Random House Proofreader \$ 39	EasySpeller II \$119	Professional Pak CALL	SOFTWARE PUBLISHERS™ PFS File \$ 95
Random House Thesaurus \$119	EasyWriter/Speller \$299	MICROSOFT® RAM Card™ \$ 89	PFS Report \$ 95
C. M. B. III ENTERPRISES™ WS-Palch and WS-Keys \$ 35	EasyFiler \$259	Softcard™ \$249	PFS Graph \$ 95
COMPUTING!™ Power! \$119	Financial Management Series CALL	Videoterm (Videx™) \$239	SORCIM™ SuperCalc \$129
CONTINENTAL SOFTWARE™ Home Accountant CALL	LEXISOFT™ SpellBinder \$239	All Three Above \$479	SuperCalc2 CALL
DIGITAL RESEARCH™ CBASIC \$109	LIFETREE SYSTEMS™ VolksWriter \$129	Mulliplan™ \$189	SuperWriter \$179
CB-80 Compiler \$379	LOTUS™ 1/2/3 \$379	Enhancer II (Videx™) \$119	SpellGuard \$129
PASCAL/MT+ \$259	METASOFT™ Benchmark \$359	BASIC 80 \$275	VISICORP® VisiCalc \$169
SPP \$155	MICROLAB™ Tax Manager \$179	BASIC Compiler \$295	VisiTerm \$ 85
Access Manager \$225	MICROPRO® Wordstar \$249	COBOL Compiler \$549	VisiDex \$189
Display Manager \$299	Wordstar/MailMerge \$349	FORTRAN 80 \$349	CALL
CBASIC 86 \$139	Wordstar/MailMerge/SpellStar \$459	FFlight Simulator \$ 45	VisiFile \$209
PASCAL/MT+ 86 \$289	Wordstar/InfoStar \$499	Multi-tool Word CALL	VisiSchedule \$209
Concurrent CP/M 86 \$249	MailMerge \$129	All Other Products CALL	VisiTrend/Plot \$279
CP/M 86 \$ 49	InfoStar \$259	MICROSTUF™ Crosstalk \$119	VisiWord \$100
FOX AND GELLER™ Quickcode \$219	CateStar \$ 89	OASIS™ The Word Plus \$129	Business Forecaster \$219
Dutil \$ 59	DataStar \$179	Punctuation and Style \$109	Desktop Planner \$219
		ORGANIC™ Milestone \$269	Specials CALL
		PBL CORPORATION™ Personal Investor \$105	FLOPPY DISKETTES (Boxes of Ten) 8" \$ 25
		PERFECT SOFTWARE™ Perfect Writer \$289	5" (SS) \$ 25
		Perfect Speller \$169	5" (DS) \$ 35
			Larger Quantities CALL

NOW, PAY LESS, AND GET GREAT SERVICE, TOO!

When you buy software from us you're in good company. You see, one of our favorite customers is IBM, itself.

That's right.

When IBM PC headquarters in Boca Raton, Florida wants to try out some competitive products, they give us a call and place an order.

So do Hewlett-Packard and General Electric and Honeywell.

Frankly, we're flattered but not surprised. Because we know we've earned a national reputation for rock-bottom prices, fast, personal service,

and outstanding product support.

Now, we'd like to go to work for you.

TAKE A LOOK AT WHAT WE OFFER.

LOWEST PRICES: Compare prices for yourself. We think you'll be impressed. (Somebody at IBM must love a bargain!)

How do we keep prices so low? By buying in tremendous volume and negotiating the best deals. (We were the *first* mail-order house in the country to sell Perfect Writer!)

FAST DELIVERY: When you call 800-SOFTWARE you get the fastest delivery available anywhere.

Which means that every order is filled the day we get it. And that our unique Order Tracking System™ is on the job, keeping tabs on your order every step of the way.

Our giant inventory — one of the largest in the United States — also assures you of the fastest possible service. Everything's in stock so you don't have to wait.

TECHNICAL SUPPORT: It's the best. When IBM calls with a question, we *better* be ready! (One day, when you have a question, you'll be glad you bought from 800-SOFTWARE.)



WRITE
800-SOFTWARE



940 Dwight Way, Ste. 14
Berkeley, CA 94710



CA residents
add sales tax.

© Copyright 800-Software 1983

Microsoft is a registered trademark, and Soficard, RAM Card, and Multiplan are trademarks of the Microsoft Corporation.

Circle 3 on Inquiry card.



TO ORDER, CALL TOLL-FREE: 800-227-4587
IN CALIFORNIA: 800-622-0678 or 415-644-3611

- Purchase orders accepted. Please call us in advance.
- Prompt UPS 3 day Blue Label.
- Call for shipping charges, free catalog, and other low software prices.
- Now open Mon. - Sat.
- International and national dealer requests welcome.
- Quantity discounts available.
- Prices may change.

list of public symbols with corresponding segment locations and offsets. A utility program, *clist*, produces paginated source listings with line numbers, fully formatted for printing, and includes a cross-referenced listing of all functions and all line numbers where they were found. Object libraries included can be called from either C or assembly language, and both options are clearly explained.

The object library supplied consists of 59 subroutines. An additional 16 routines for IBM PC screen and keyboard handling are included in a separate assembly-language source file that may be assembled and linked with C or assembly-language object modules. A C implementation of the game of Life, invented by English mathematician John H. Conway, is included in both executable and source-code forms to illustrate the use of this comprehensive assembly-language PC screen handler.

Two other source files accompany this package. A core-style file-dump

utility illustrates the use of file and screen I/O routines. An assembly-language source file for an operating-system utility patch, which extends the keyboard input buffer from its current 15 to a full 128 characters, illustrates use of the system assembler. Both are included in executable form and are valuable as programs and as examples.

Although brief, the documentation devotes just enough attention to each feature in this extensive package to supply the user necessary information. The lack of an index seems less noticeable here than in some other documentation due to the clear structural organization and the inclusion of a functionally subdivided listing of library routines in the table of contents. All programs include extensive error messages, which are fully documented.

Intellect Associates C88 is a one-pass, nonoptimizing, integer-only subset compiler that seems to be constructed on a foundation of the public-

domain small-c source but incorporates many enhancements. Memory usage is limited to the 64K-byte 8080 .COM file format, with the origin of a user's program set at the address 100 hexadecimal. The somewhat non-standard subset of C this compiler supports is limited, but fortunately the documentation clearly outlines what is missing. A function library consisting of 44 individual object files requires the supplied linker to form an executable file. No run-time I/O redirection for the user's programs is supported. Modules may be compiled without a main, so they can be used as subroutines in addition to the object files supplied.

The two allowable data types are *int* and *char*, and pointers may point only to these. Structures, unions, compound assignments, *goto*, the storage classes *auto*, *static*, *extern*, and register and typedef declarations are not allowed. Multidimensional arrays are not permitted, and subscripting either an integer array or a pointer to an integer—in contrast to standard

PROGRAMMERS "C" the extras we offer

More than just a compiler . . . we address the total programming environment

C Compiler —

- Complete non-float implementation (float avail 3Q) per Kernighan and Ritchie.
- Small and medium models supported. Medium model allows greater than 64k of code and greater than 64k of data.
- Complete standard I/O package.

c-window™ — Source level debugger

- Fully interactive symbolic debugging.
- Full C expression evaluation during debugging.
- Statement and expression breakpoints.
- Automatic commands provide multiple variable display per single step or breakpoint.

Ask for a demonstration package — you'll immediately "C" the difference!

Available for Victor 9000, IBM PC, Zenith Z100, other MSDOS systems. Inquire about CP/M-86 version.

C Compiler \$195.00
c-window \$195.00
c-window demo package
(w/manual and diskette) \$45.00

Prices subject to change without notice.

c-window tm c-systems; IBM tm IBM Corp.; MSDOS tm Microsoft; TI Professional tm TI; CP/M-86 tm Digital Research.

c-systems

P.O. Box 3253 • (714)637-5362
Fullerton, CA 92634

PROGRAMMING IN C ? BE SURE YOU GET ALL THE PHACT'S !

base your C programming on
PHACT-dbrm
a multi-keyed (I S A M)
Data Base Record Manager.

PHACT-dbrm
is an easy to use library of C callable functions for manipulation of records in a database, plus high level database manipulation tools.

PHACT-dbrm
supports: data dictionary; 5 datatypes; variable length records; full database security; database locking, data portability; ".h" file creation and much much more!

PHACT-dbrm
runs on: all UNIX systems • IDRIS and UNIX look-alikes • MSDOS • CP/M

PHACT-rgl (Relational Query Language) **PHACT-rg**
(Report Generator) and **PHACT-rsg** (Relational Screen Generator)
under development.

PHACT-dbrm
is priced between \$250-\$950. (Source available)



To get all the PHACT's call DAVID GRAHAM at
PHACT ASSOCIATES Ltd • 212 • 420-1512
231 EAST 11 STREET • NEW YORK • NY 10003

THE ONE AND ONLY CRAMBO

You've got a problem. Go to your favorite computer store. Ask to see their Combo Cards. Then ask about their RAM Cards. See the problem? Just too many to pick from. Now, ask to see the CRAMBO™. No problem. There's only one. Ours. Except you don't know what a CRAMBO is. You've probably guessed it's a Combo Card piggy backed to a RAM Card. So it only takes up one slot in your IBM/PC. That's right. But here are the details.

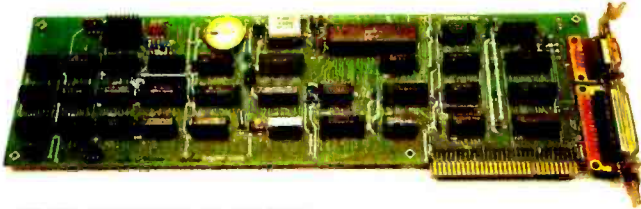

THE COMBO II CARD:

For **\$189** you'll get a Clock Calendar, Async Communications, Parallel Printer and a Game Adapter.

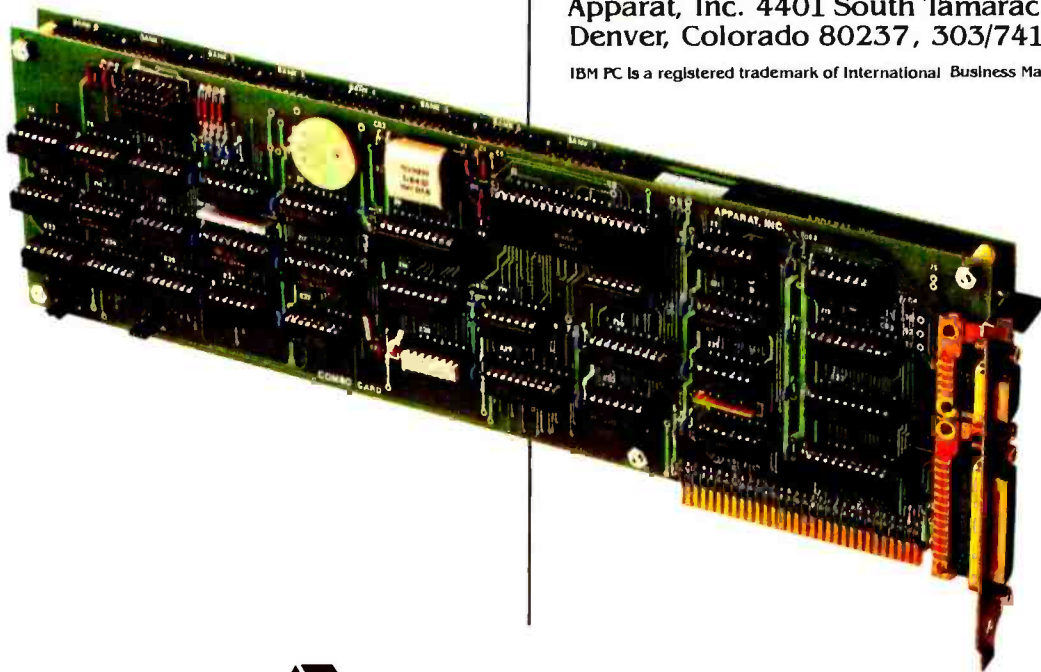

THE 512K RAM CARD:

It too, is only **\$189** with 64K of RAM installed. And when you need more RAM, 64K increments are available for \$64 each. And, SDRIVE, the electronic disk emulator, is available at no cost with the RAM Card.

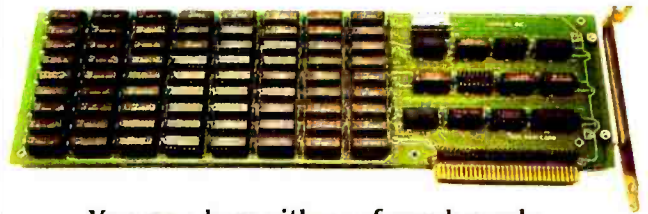

You can buy either of our boards separately for use in the XT or PC expansion chassis. But only our boards can be piggy backed to give you the one and only CRAMBO. And for only **\$359**.

Go check out the CRAMBO at the same store carrying all those Combo Cards and RAM Cards. If they don't have the CRAMBO have them call us. **800/525-7674**. Or write: Apparat, Inc. 4401 South Tamarac Parkway, Denver, Colorado 80237, 303/741-1778.

IBM PC is a registered trademark of International Business Machine Corp.

 **Apparat, Inc.**

Eye-Guard™

the only anti-glare shield* made with lead to cut eye fatigue caused by glare, X-rays, UV radiation & microwaves from computer terminals.

The new Eye-Guard anti-glare screen shield is made of strong, impact-resistant, lead-impregnated acrylic.

It is identical to the material used as windows by nuclear power plants and hospital x-ray facilities to block radiation and protect personnel. And, even though Eye-Guard screen shields contain 30% lead (by weight), they are completely transparent.

Whether your eye-fatigue is caused by glare, radiation, or both, from your computer terminal, Eye-Guard will give your eyes relief.

Eye-Guard is the only anti-glare shield on the market made with lead. It's the only product that can make that claim.

It is so effective at reducing eye-fatigue and

*Attaches to computer terminal with convenient Velcro tabs.



eliminating the possibility of damage to your eyes from computer generated radiation that it's sold with a 100% money-back guarantee of satisfaction.

If your eye-fatigue isn't absolutely eliminated in the first 30 days, we'll buy back the Eye-Guard Leaded Screen Shield for the full purchase price.

Order your Eye-Guard Leaded Acrylic Anti-Glare Radiation Shield today. 9½" x 11½" or 10" x 13," complete with velcro fasteners for easy attachment to most monitor screens, **\$129.95.**

Eye-Guard Leaded Acrylic Radiation Shields (without anti-glare filter), **\$119.95.**

Dealer inquiries invited.

Mail to:
Langley-St. Clair Instrumentation Systems, Inc.
132 W. 24th St., New York, NY 10011

Please ship the following Eye-Guard Leaded Acrylic Radiation Shields:

— 9½" x 11½" and/or 10" x 13" with anti-glare filter @ \$129.95 \$ _____
— 9½" x 11½" and/or 10" x 13" without anti-glare filter @ \$119.95 \$ _____

Total number ordered _____
Ship Regular UPS UPS Blue Label
Parcel Post Overseas

Add \$4.00 each for shipping and handling.
Add \$10.00 for shipping overseas, parcel post or UPS Blue Label.
Add sales tax where applicable.

Charge to my MasterCard Visa

No. _____ Expires _____

My check for \$ _____ including shipping costs enclosed.

Ship to:

NAME _____

ADDRESS _____

CITY _____ STATE _____ ZIP _____

syntax—will double the subscript evaluation. Arguments to #defines are not permitted, and #includes may not nest.

All constant expressions are evaluated at run-time (rather than at compile time, which would be faster), and function arguments must be defined in the order in which they appear in the function declaration. The compiler considers all undeclared but referenced functions or variables to be external functions and sends necessary external references to the object file. The user must examine the list of external identifiers printed at the end of compilation for incorrect entries such as misspelled variable names.

Function calls have a decidedly nonstandard but potentially interesting feature for the absolute-address adventurer. Almost anything you can imagine immediately followed by ((the open parenthesis) is compiled as a function call. Thus 1000() would call absolute memory location 1000 decimal and array[i]() would call the location whose address is found in the ith member of the array. Arguments to such functions are pushed onto the stack in the order in which they appear within the parentheses.

Most of the object files that constitute the library have nonstandard names, syntax, and functions and do not include routines for heap management or string handling. Several useful PC console interface, BIOS interface, special-purpose disk I/O, and memory-utility functions are also on the disk. The 60 pages of documentation are neither well structured nor oriented to the novice. After considerable groping about, however, I found most of the information I needed.

C88 was fast at compiling its limited subset of the C language, and it generated some of the smallest executable files. The supplied interactive linker was equally rapid and only required input of files actually used by the final program. I felt a certain frugal satisfaction at seeing this software produce an executable utility program to clear the PC's display screen that occupied only 128 bytes

Langley-St. Clair Instrumentation Systems, Inc.

132 W. 24th St., New York, NY 10011

Circle 234 on inquiry card.

Microsoft languages connect your software to more 16-bit systems.

The largest market for 16-bit software. Over 95% of all 16-bit microcomputers run Microsoft® operating systems, languages, or both. That means your programs written in Microsoft languages find their market in the largest installed base of 16-bit systems. The IBM® PC, and systems from Wang, Zenith, DEC, Victor, Altos, Texas Instruments and Radio Shack, to name just a few. And, if you're working with Microsoft operating systems and languages, you'll find that it's far easier to transport software between systems.

A full range of languages. The versatile MS-BASIC interpreter and the fast MS-BASIC compiler, Microsoft Business BASIC and MS-COBOL for business use. MS-FORTRAN for scientific and engineering applications. Microsoft C, a complete C, that provides a productive alternative to assembly language. And MS-Pascal, a high-level language compiler specifically designed for microprocessor system software implementation. All these languages are compatible with ANSI or ISO standards.

A total programming environment. Compatible languages. Operating systems. Utilities. Plus complete support. All the tools you need to write software that sells.

Leadership in micros.

Microsoft wrote the first BASIC for the

first production microcomputer. Since then, we've added a full range of 8-bit and 16-bit languages, plus the MS™-DOS and XENIX™ operating systems. What's more, we are constantly enhancing both languages and operating systems. And we make those enhancements available to our customers. That means Microsoft programming languages are state-of-the-art programming tools. Tools that allow your applications programs to reach more systems. More effectively.

More information? See your Microsoft dealer for complete information on Microsoft's 16-bit languages and operating systems. Or, write for our booklet, "The Microsoft Language Family." A family of tools that give your programs access to the largest installed base of 16-bit systems.

BETTER TOOLS FOR MICROCOMPUTERS

MICROSOFT™

MICROSOFT CORPORATION
10700 NORTHUP WAY
BELLEVUE, WASHINGTON 98004



Microsoft is a registered trademark, and MS, XENIX and the Microsoft logo are trademarks of Microsoft Corporation.

Need to Measure Your Corporate Communications?

Want to define your company's image? Measure competitive strengths? Determine the acceptance of your company publications? Gauge reactions to your annual report? Determine the effectiveness of your corporate advertising? Monitor the impact of important trends and developments on your company's business?

Call McGraw-Hill Research

Backed by 30 years of research experience covering scores of markets and fields, McGraw-Hill Research professionals design custom projects that can make a big difference in the success of your corporate communications efforts. The Corporate Communications Research Center will meet your research needs promptly, at a reasonable price.

Put McGraw-Hill Research to work for you.

For a quote or proposal, call Joan Bullen, Director-Corporate Communications Research Center at (212) 997-3517 or Eleanor Nicoletti, Project Director, at (212) 997-3095. Or, write Corporate Communications Research Center, 1221 Avenue of the Americas, New York, NY 10020



If it's a communications problem, we probably pioneered the solution.

on the disk. Other compilers impose a minimum overhead of 6 to 10K bytes on executable files by including mandatory I/O redirection, even for those programs where this is unused and totally inappropriate. However, the performance of the code generated, especially in such critical areas as looping and local-variable access, is inadequate for any serious production work, particularly when compared to the price/performance ratio of other available software.

Lattice C, in addition to the two-pass compiler, includes a standard library in object form, an object module disassembler, three header files, a source function-extraction utility, and sample C source files. A run-time package supports full I/O redirection. The 150-page manual includes a detailed table of contents and a comprehensive index. With the addition of an object-code librarian, this compiler is marketed as the Microsoft C compiler.

The Lattice C compiler produces remarkable code. In integer and floating-point math evaluation, pointer and array handling, local-variable access, and function calling, performance was outstanding in terms of both execution speed and code compactness. Most measures applied to the compiler group echoed this superiority. Not only was the code fast and compact, but the Lattice compiler was consistently second only to the DeSmet compiler in compiling and linking speed in both memory-disk emulator and floppy-disk environments.

Rapid compilation and high-performance code are crucial in a production environment where they facilitate an interactive "successive approximation" style of coding. This compiler encourages the programmer to code in small units, testing each as he goes, rather than build untested monoliths that require laborious debugging.

In extensive use over an 8-month period, the Lattice compiler has performed reliably and predictably, even when facing intentionally nasty traps and errors. The preprocessor handles

Text continued on page 158.



INTRODUCES: PC-VSAM™

™

- one of the most comprehensive and versatile I/O programs available with power and performance to match that of the IBM-PC.®
- uses sophisticated and easy command language that allows flexible and efficient storage of information.
- meets the challenge of today's complex system and application needs while saving time and money in development.

SYSTEM REQUIREMENTS: IBM-PC™, DOS, 64K RAM, ONE DISK DRIVE-5¼", 80 COLUMN DISPLAY, OPTIONAL PRINTER

INTRODUCTORY PRICE: \$155.00

(Offer good through Sept. 7, 1983)

In order to enable us to market the most economically priced software we use functionally-inexpensive packaging™. Thus, passing the savings on to you.

PROFESSIONAL BUSINESS SPECIALISTS,™ INC.

P.O. Box 026005

Miami, Florida 33102-6005

Call Collect (305) 545-7077

For Information and Specifications.

Method of Payment: Check. Money Order.

Terms: All Handling and Shipping are included in Software price. Allow 2-4 weeks delivery.

Trademark: IBM is a registered trademark of International Business Machines, Corp.

PROFESSIONAL BUSINESS SPECIALISTS, FUNCTIONALLY-INEXPENSIVE PACKAGING, PC-VSAM, PBS are Trademarks Pending of PROFESSIONAL BUSINESS SPECIALISTS, INC.

COMPETITIVE EDGE

WELCOME TO THE GREAT LAKES EXPANSION CELEBRATION

SLUDER HAS EXPANDED AND RELOCATED AND IS NOW READY TO SERVE YOU EVEN BETTER THAN BEFORE. WE ARE CELEBRATING AND TO HELP YOU JOIN US WE ARE FEATURING THIS MONTH SOME BRAND NEW ITEMS AND HAVE CUT EVERYDAY SALE PRICES EVEN FURTHER.

COMPUPRO™ FROM GODBOUT ELECTRONICS

FULLY INTEGRATED



816-A A&T	\$ 3995.	CSC \$ 4449.
816-B A&T	\$ 5095.	CSC \$ 5690.
816-C A&T	\$ 6566.	CSC \$ 7335.
816-D A&T	\$10216.	CSC \$11676.
816-08 A&T	\$ 6566.	CSC \$ 7335.
816-16 A&T	\$10216.	CSC \$11676.
816-68K AT	\$ 6566.	CSC \$ 7335.
20 MEGABYTE SUB-SYS W/DISK 2	3495	CSC \$ 3595.

COMPETITIVE EDGE INTEGRATED BUDGET SYSTEMS

85/88, 64K, I/O-I, 10 SLOT, CP/M, (2) 8" DSDD	\$3095.
6MHZ CPU Z, 64K, I/O-I, 10 SLOT, CPM, (2) 8"	2995.
10MHZ 8086, 128K, I/O, 10 SLOT, CPM, 2-8"	3895.
10MHZ 8086, 256K, I/O-3, 10 SLOT, MPM, 2-8"	5495.
10MHZ 8086, 512K, I/O-3, 10 SLOT, MPM, 20MB	9995.
10MHZ 68K, 128K, I/O-I, 10 SLOT, CPM, 2-8"	3895.
CPU 80286, 128K, I/O-I, 10 SLOT, CPM, 2-8"	4495.
DISK 1 & CPM-2.2	\$ 445.
DISK 2 A&T	507.
CPU 80286 A&T	\$1164.
CPU 80286 CSC	1268.
CPU 68000 A&T	499.
CPU 68000 CSC	621.
M-DRIVE-H A&T	1383.
ENCLOSURE 2 DESK	595.

SEATTLE COMPUTER PRODUCTS

GAZELLE, 128K, LIST \$5995.	SALE \$4695.
15 MEGABYTE HARD DISK FOR GAZELLE INCLUDES CONTROLLER & SOFTWARE	1895.
SEPARATE CABINET & 15 MB HD	2095.

COMPETITIVE EDGE BUDGET SYSTEM

SEATTLE 86 CPU SET, 128K, (2) 8", MSDOS 2.0, 10 SLOT CAB. POWER SUPPLY, READY TO RUN POWER SUPPLY, READY TO RUN	3395.
CE INTEGRATED SYSTEM W/ 1-8" DR, 15 MEGA- BYTE HARD DISK, 8086 SET, MSDOS 2.0, 128K OF FAST SEATTLE STATIC RAM.	4995.
8086 CPU SET, MSDOS \$595.	64K STATIC RAM 475.
SCP DISKMASTER	319.
SCP 2 PORT SERIAL	175.
SCP 4 PORT SERIAL	210.
8087 PACKAGE	263.

SEATTLE RAM+ & RAM+ 3 FOR IBM PC

RAM+ 64K \$199. 128K 249. 192K 299. 256K	350.
RAM+ 3 64K 269. 128K 319. 192K 369. 256K	420.
8087 PACKAGE W/8087 & BASCOM. LIB	263.

HARD DISK SUB SYSTEMS FOR ANY Z80 CPM COMPUTER

10 MEGABYTE INCLUDES SOFTWARE CAB. & CONTROLLER	\$1795.
22 MEGABYTE INCLUDES SOFTWARE CAB. & CONTROLLER	\$2295.
44 MEGABYTE INCLUDES SOFTWARE CAB. & CONTROLLER	\$3995.

ABOVE FOR CP/M OR TELETEK TURBODOS DEALER PRICES AVAIL.

LOMAS DATA PRODUCTS INC.

8MHZ 8086, LDP72, HAZITALL, 256K DRAM
4 BOARD SET FROM LOMAS

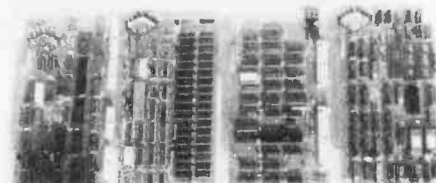

**AUGUST
SALE
\$1399.**

LOMAS S100 PC 2-5" DRS, 8MHZ 8088 \$2499.
128K RAM, LDP72, HAZITALL, MSDOS, 15 SLOTS

COMPETITIVE EDGE INTEGRATED SYSTEMS

8MHZ 8086, 128K DRAM, 2.4 MB 2-8" DRS, 10 SLOT	2995.
10MHZ 8086, 128K STATIC, 2-4 MB, 10 SLOT	3795.
LOMAS 286, 128K, 2.4 MB 2-8" DRS, 10 SLOT	4995.
2 USER MPM 86, 86/89, 256K, 10 SLOT, 2-8"	3895.
5 USER MPM 86, 86/89, 512K, 10 SLOT, 1-8" 8MBHD	6595.
5 USER MPM 86, 86/89, 512K, 10 SLOT, 1-8" 32MBHD	8095.
4 BOARD SET AUGUST ONLY, 86, LDP72, HAZ, 256K	1399.
8MHZ 8086 \$420., LDP72 \$220., HAZITALL	\$260.
10MHZ 8086 \$520. 128K STATIC \$875. 256K DRAM	636.

TELETEK

TELETEK OFFERS FINE SINGLE & MULTI-USER COMPONENTS IN THE 4 & 6MHZ Z80 SERIES

Z80A, 64K, 2-5" .6 MEGABYTE FLOPPY \$1795. SYSTEM W/2 SERIAL, 2 PARALLEL PORTS AND CP/M 2.2 OPERATING SYSTEM	
10 MEGABYTE HARD DISK FOR ABOVE	1795.
22 MEGABYTE HARD DISK FOR ABOVE	2295.
Z80A, 64K, 2-8" 2.0 MEGABYTE FLOPPY SYSTEM W/2 SER. 2 PAR PORTS, CP/M AND 10 SLOT S-100 CABINET	2495.
Z80A, 64K, 1-8" DR, 1-10MB HD, TWO Z80A SLAVES, TURBODOS NETWORK O/S 10 SLOT CABINET, EXPAND TO 9 USERS BY ADDING MORE SLAVES. 22MB AVAIL. MANY CONFIGURATIONS UP TO 16 USERS	
TELETEK SYSTEMMASTER \$671.	Z80A SLAVE \$649.
Z80B SLAVE	756.
TELETEK HD/CTC	596.
CP/M 2.2	165.

DEALER CORNER

DEALER PRICES AVAILABLE ON SYSTEMS,
HARD DISK SUB SYSTEMS & BARE DRIVES
TELETEK COMPONENTS AT SPECIAL DEALER
PRICES. WE DISTRIBUTE SPELLBINDER
FOR IBM PC AND ALL CP/M COMPUTERS

MANY TERMINALS (QUME 102 \$535.), PRINTERS, & ALL CP/M & IBM PC SOFTWARE AVAILABLE

COMPETITIVE EDGE • P.O. BOX 556 • PLYMOUTH, MI 48170
800 ORDER LINE 1-800-336-1410 LOCAL & INFORMATION LINE 1-313-451-0665
VISA & MASTERCARD ACCEPTED NO SURCHARGE

CP/M & MPM ARE TRADEMARKS OF DIGITAL RESEARCH. TURBODOS IS A TRADEMARK OF
SOFTWARE 2000 INC.. COMPUPRO™ IS A TRADEMARK OF GODBOUT ELECTRONICS

PROGRAMMING INTERNATIONAL

Apple DOS

Applied Software Technology

	LIST	SALE
Versaform	389	269
Versaform-Pascal ..	245	180
Versaform/Corvus Hrd Disk	495	360

ARTSCI

Magic Mailer	70	49
Magic Pack Combo	225	156
Magic Window	100	75
Magic Window II	150	109
Magic Words	70	49

Avant Garde

Ultra Plot/DIF/Datagraph	99	71
--------------------------------	----	----

Beagle Brothers

Apple Mechanic	30	22
Beagle Bag	30	23
DOS Boss	24	17
Double Take	35	27
Flex Text	30	23
Pronto DOS	30	23
Utility City	30	22

BPI

GL, AR, AP, Payroll, JobCost, Inventory (ea)	395	320
--	-----	-----

Broderbund Software

Bank Street Writer	70	53
General Ledger w/AP	495	305
Payroll	395	275

Computer Station

Combined Enhanced Graphics	55	40
Station Master	175	136

Comshare

Image Maker	175	126
-------------------	-----	-----

Continental Software

CPA #1, 2, 3, 4 (all 4)	[5] 1000	600
CPA #1-GL	250	159
CPA #2-AR	250	159
CPA #3-AP	250	159
CPA #4-Payroll	250	159
CPA #5-Property Management	495	352
FCM (First Class Mail)	100	75
Home Accountant	75	52

Crane

Menu Generator	40	29
----------------------	----	----

Creative Curriculum

Speed Reading Courseware	99	75
--------------------------------	----	----

Dakin 5

Business Book-keeping System	395	299
Budget Planner	150	112
Depreciation Planner	395	299

Datamost

Reap (Real Estate)	130	90
Tax Beater	130	90
Write On	130	99

Datsoft

BASIC Compiler	100	75
Lisp Interpreter	125	94
Micropainter	35	25

Decision Software

Accountant	129	97
Accountant with DBCalc	149	112
DBCalc	0	20

Delta Software

Bookkeeper Check Writer	40	29
Bookkeeper Master	90	68

Denver

Financial Partner	250	188
Pascal Programmer	296	223
Pascal Tutor	125	97

Eduware

Algebra 1	40	30
Algebra 2	40	30
Algebra 3	40	30
Algebra 4	40	30
Algebra 5 & 6	50	38
Compu-Math/Arithmetic Skl	50	37
Compu-Read	30	22
Compu-Spell/Data Disk 4-8 (ea)	20	15
Compu-Spell/System	30	22
Counting Bee	30	22
Decimals	49	37
Fractions	49	37
Metri-Vert	16	12
Perception	25	19
PSAT Word Attack	49	37
Rendezvous	40	30
SAT Word Attack	49	37
Spell Bee w/Reading Primer	40	30
Statistics	30	22

GL, AR, AP, Payroll, Job Cost

Inventory (ea)	395	320
----------------------	-----	-----

Hayden

Writer/Multi-Column	150	108
Writer/Standard	150	108

Heyes

Micromodem II w/Term Point	409	289
Terminal Program	100	75

Highlands

CRAE	40	30
EZ Ledger	60	37
MCAT	25	19

Howard

Creative Financing 1983	195	149
Real Estate Analyzer	195	146
Tax Preparer 1983	225	179

IUS

Datadex	150	108
Datadex Hard Disk	300	216
Easy Mover	100	75
Form Development System	140	101
Tellstar Level 1	40	30
Tellstar Level 2	80	58

Insolt

ALD System II	75	56
Electric Quiet	30	23
Graforth II	75	56
Transforth II	125	94

ISM

Graphmagic	90	65
Mathemagic	90	65

Kensington

Format II	150	113
-----------------	-----	-----

Lightning

Master Type	40	30
-------------------	----	----

Link Systems

Data Fax	199	149
Data Link	100	75
Link Disk	70	51
Link Index	195	149
Link Sampler I	60	45
Link Video	55	42

LJK Enterprises

Data Perfect	100	78
Edit 6502	100	78
Lettr Pict w/Mail Merge	150	112

Lotus

Executive Briefing System	199	149
---------------------------------	-----	-----

Micro Lab

Asset Manager	200	144
Data Factory	300	216
English SAT #1	30	22
Invoice Factory	200	144
Learning System	150	108
Merger	50	37
Painter Power	40	30
Payroll Manager	300	216
Tax Manager	180	129
US Constitution Tutor	30	22
VisiWord	50	37
VisiFactory	75	54
Will Streamer	300	216

Microsoft

Applesoft™ Compiler™ (TASC)™	175	119
Multiplan™	275	198
Math/Simp™ (ADIOS)	250	194
Time Manager™	150	110
Typing Tutor II™	25	19

Muse

Address Book	50	36
Datapur	60	43
Elementary math Form Letter Modules	40	29
SuperText Home Office	100	75
Professional	125	94
The Voice	40	29

Omega

Inspector	60	44
Locksmith	100	75

Optimized System Software, Inc

Special Read Plus	60	44
-------------------------	----	----

PBL

Personal Investor	145	99
-------------------------	-----	----

Paragon

Additional Fonts Char Set	20	15
Comp Graphics/Apple Tablet	120	86

Complete Graphics System

Graphics Magician	60	45
Special Effects	40	30
Special Effects Apple Tablet	70	50

Phoenix

Zoom Graphics	50	38
---------------------	----	----

Program Design

New Step-By-Step	80	58
Step by Step II	90	70

Quality Software

Bag of Tricks	40	30
---------------------	----	----

GBS—DB Appl Dev Program

.....	650	488
-------	-----	-----

Sensible

Applesoft + Struc. BASIC	40	30
Best	40	30
Bug, The	50	32
Build Using	30	23
Disk Organizer	30	23
Disk Recovery	30	23
DOS Plus	25	19
Edit Soft	40	30
Image Printer Epson	40	30
Image Printer Letter Qual	40	30
Image Prtr NEC/Dot Matrix	40	30
Multi Disk Catalog	25	19
Quadrant 6112	30	23
Quickloader	25	19
Sensible Speller	125	94
Sensible Speller Pascal	125	94
Sens Speller Word Handler	125	94
Super Disk Copy	35	26

Sirra On Line

Dictionary	100	70
Emrv	80	56
General Manager II	250	168
LISA	80	56
LISA Educational System	120	83
Screenwriter II	130	85
Screenwriter Professional	200	149

Silicon Valley

Dictionary	125	94
List Handler	90	56
Word Handler	195	145

Sirius

Pascal Graphics Editor	100	75
------------------------------	-----	----

SOFTSYS

Executive Secretary	250	188
Executive Speller	75	56

Softech

BASIC Compiler & Runtime	[5] 225	169
Softtech	125	94
UCSD p-System Set	[5] 625	469
Xenofila	50	38

Apple IIe

Most Apple IIe products also run on the IIc (call for details). Products below are specially designed for the IIe.		
--	--	--

Software Dimensions

	LIST	SALE
Accounting + IIe	395	289
+ AR	395	289
+ GL	395	289
+ Inventor	395	289
+ Payroll	395	289
+ POE	395	289
+ POS	395	289
+ SOE	395	289

Software Publishers

PFS: File	125	94
PFS: Graph	125	94
PFS: Report	125	94

Visicorp

Visicalc	250	189
----------------	-----	-----

Applied Software Technology

Versaform	495	371
-----------------	-----	-----

Datamost

Write On	130	99
----------------	-----	----

Denver Software

EASY	750	562
------------	-----	-----

Insolt

ALD System III	75	56
Transforth III	125	94

Link Systems

Data Fax	249	187
Link Index	195	149
Link Sampler I	60	

Your CPM & HARDWARE Source

PROGRAMMING INTERNATIONAL

CP/M-80

8" standard SSSD and Apple 5 1/4". Please call to confirm price & availability for other formats, available as special orders.

Mark of The Unicorn	LIST	SALE	MAC	30	13	Calcstar	15	96	• AR†	400	275	CP/M-86	LIST	SALE
Final Word	300	223	Pascal MT +	350	262	Datastar	25	195	• GL†	400	275	Ashton-Tate	LIST	SALE
Mince	175	139	Pascal MT+ with			Infostar	45	327	Series 80 Pak			dBASE II	[5]	700 398
Adventure International			SPP	500	395	Mailmerge	30	165	(GL,AR,AP)†	[5]	595 398	dBASE II w/User's		
Adventures			PL/1 80	500	375	Reportstar	30	231	• AP†	400	275	Guide	[5]	729 419
1-12 (Req Z80)	129	97	SID	75	63	Spellstar	20	165	• AR†	400	275	Digital Research		
ATI			SPP	200	150	Supersort	20	165	• GL†	400	275	Pascal MT + 86		
Power for CP/M	75	54	ZSID	100	88	Word/Mail	[5]	695 426	• Inventory†	400	275	w/SPP-86	490	600
Anderson-Bell			DJR Associates, Inc.			Word/Spell	[5]	695 426	Pearl Soft			X-T 86	150	132
ABSTAT	359		FMS 80	995	625	Word/Spell-Mail			Personal Pearl	295	184	Word		
Artificial Intelligence			FMS 80-1	495	312				Quality			MoveIt	150	99
Dental (PAS-3)	995	749	FMS 80-2	495	312	Wordmaster	150	99	GIS—DB App	650	488	HARDWARE		
Medical (PAS-3)	995	749	Eagle			Wordstar	[5]	495 327	Dev Prog			(not machine specific)		
Ashton-Tate			Citation	250	169	Microsoft			Select			Amdek	LIST	SALE
Bottom Line			Ecosoft			BASIC 80™	350	252	Select Word			300		
Strategist	400	279	Microstat	295	248	BASIC Compiler	395	276	Processor	495	356	(12" Green)	[10]	200 157
dBASE II	[5]	700 398	Microstat 3.0	395	320	COBOL 80™	750	542	• AR	645	398	300A		
dBASE II w/User's			Supervyz	150	94	FORTRAN 80	500	360	• GL	645	398	Color II (RGB)	[10]	499 645
Guide	[5]	729 419	Epic			MACRO 80™	200	150	• Inventory	645	398	Corvus Systems		
Aspen Software			Falcom			μLips/μStar™	200	156	• Payroll	645	398	6MB Hard		
Grammatik	75	56	Micro B + (CBasic)	260	211	Multiplan™	245	198	• POE	645	398	Disk	[10]	2295 1895
Proofreader	50	38	Micro B + (Other)	260	211	μMath/μSim	240	194	• POS	645	398	1MB Hard		
Balcones			Fox & Geller			Sorting Facility			• SOE	645	398	Disk	[10]	3295 2695
BOSS Fin. Acctg			dGRAPH	295	195	(MSORT)™	105	151	Sorcim			20MB Hard		
System	2495	1496	dUTIL	99	59	Text Editor™	120	94	ACT 65	175	126	Disk	[10]	4295 3495
Byrom Software			Quickcode	295	195	Microsoft			ACT 68	175	126	Daisywriter		
BSTAM	200	149	Quickscreen/			Crossalk			ACT 69	175	126	Printer	[10]	1395 1235
BSTMS	200	149	CBasic	149	125	Smartmodem	195	135	ACT 80	175	126	Hayes		
Caxton			QuickGreen			Northwest Analytical			ACT 86/88	175	126	Chronograph	[5]	249 199
Cardbox	245	177	dBASE II	149	125	Statpak	495	369	Pascal/M-80	395	284	Smartmodem	[5]	699 509
Comm soft			Quickcode	149	125	Oasis			Pascal/M-86/88	495	356	300	[8]	279 209
Roots/M	195	142	FMS 80	149	125	The Word Plus	150	112	Supercalc	295	129	3430		
Computer Control			Quickscreen			Organic Software			Supercalc 2	295	179	Smartwriter	[10]	3790 1735
FABS-BTree File			MBasic	149	125	Datebook	245	229	Superspellguard	195	129	8023 Dot		
Access	195	146	FYL line	195	129	Milestone	295	299	Superwriter	295	185	Matrix	[10]	695 495
Ultrason II	195	146	Superfile			Peachtree			Trans 80	175	126	Monitor 1" Green	[10]	285 167
Computer development			Human Soft			Series 4 Pak			Southwestern			Hi. Res.	[10]	285 167
Image	495	356	dBPlus	125	95	(GL,AR,AP)†	[5]	595 398	Z-Term	100	75	Novation		
Comshare			Infocom			• AP	600	398	Z-Term			Smart Cal 103	[4]	259 207
Planner Calc	99	74	Deadline	60	43	• AR	600	398	Professional	150	109	Smart Cal 103/	[4]	595 476
Target Application			Starcross	50	49	• GL	600	398	Supersoft			212		
Guide	50	38	Suspended	50	38	Inventory	500	398	Ada Compiler	300	225	Quadram		
Combo Pak	125	94	Zork I	50	38	• Payroll	50	515	Analiza II	50	38	Microfazer		
Condor			Zork II	50	38	• Sales Inv.	50	515	Disk Doctor	100	75	• In-line serial		
Condor 1	295*	189	Zork III	50	38	Peachpak Series 9	500	345	Dungeon Master	40	30	• In-line parallel		
Condor 3	650	398	ISM			• Mailing List	275	258	Nemesis	45	34	330 270		
Designer Software			Mathmagic	100	72	• Peachcalc	275	258	Scratchpad	295	221	225 185		
Palantir	425	356	Intec Intersystems			• Peachtext	600	345	T/Maker Co.			275 215		
Dietronics			Pascal 8Z	450	375	• Proofreader	600	206	T/Maker III	275	215	Wolf Software Systems		
Ransom House			Pascal Z	450	375	• Telecom	375	258	MoveIt	125	83			
Thesaurus	150	113	Pascal Z & BZ	650	542	Series 40 Pak								
Digital Research			Lexisoft			(GL,AR,AP)†	[5]	595 398						
Access Manager	300	225	Spellbinder	495	281	• AP†	400	275						
CB80	500	395	Metasoft											
CBasic	150	94	Benchmark Mail											
CIS Cobol	800	595	List	250	184									
Despool	50	38	Benchmark											
Display Manager	400	295	Wordprocessor	500	367									

TERMS: All prices subject to change without notice and availability. Cashier's check/M.O/bank transfer. Allow time for company or personal checks to clear. Prices reflect cash prepaid discount. VISA/MASTERCARD/COD/PO's + 3% CA residents add sales tax. All sales include games & special orders.

SHIPPING: \$3 per item/box UPS surface (\$4 for Blue Label) within Continental USA, except where shipping cost is specified in square brackets. UPS does not go to Canada, Alaska, APO's, FPO's, call for ship charge or add 15%—we will refund credit difference.

RETURNS: Must have authorization number, obtained at 415-324-0305. Unauthorized returns will be refused; damaged goods will be refused. All returns subject to 15% restocking fee. No return after 30 days.

PROGRAMMING INTERNATIONAL
505 HAMILTON AVE. • SUITE 301
PALO ALTO, CA 94301
(800) 222-8811
Inland California
(415) 324-3730

TELEPHONE ORDERS
Outside Calif.: (800) 222-8811
Inside Calif.: (415) 324-3730

Order lines are manned 8:30-6 Monday thru Friday and 9-5 Saturday. Other lines are open 9-5 Monday thru Friday.

Technical Support (415) 324-0311
Order Status (415) 324-0306
Sales Manager (415) 324-0305

More CP/M*, APPLE*, IBM PC*, UNIX*, UCSD p-System™ software, hardware, etc. call for quote.

Orders must be PAID by AUGUST 31 to qualify for these special prices!

FLOPPY DISK DRIVES - 8"**PRICE QTY. ONE****QUME**

242 - Half height DSDD 48TPI	450.00
842 - Full size DSDD 48TPI	465.00

TANDON

TM-848-2 - Half height DSDD 48TPI	399.00
-----------------------------------	--------

MITSUBISHI

M-2894 - Full height DSDD 48TPI	455.00
M-2896 - Half height DSDD 48TPI	455.00

FLOPPY DISK DRIVES - 5 1/4"**QUME**

142 - Half height DSDD 48TPI	195.00
542 - Full size DSDD 48TPI	260.00
592 - Full size DSDD 96TPI	335.00

REMEX

RFD-480 - Two-thirds height DSDD 48TPI	245.00
RFD-960 - Two-thirds height DSDD 96TPI	290.00

(IBM compatible; full-height face plate option available, N/C; 6-month warranty)

TANDON

TM-100-2 - Full size DSDD 48TPI	255.00
TM-100-4 - Full size DSDD 96TPI	365.00

(For the IBM PC)

MITSUBISHI

M-4853 - Half height DSDD 96TPI 1MB	335.00
M-4854 - Half height DSDD 96TPI 1.6MB	395.00

WINCHESTER HARD DISKS**AMPEX**

Pyxis 7 - 5 1/4" 7MB capacity	650.00
Pyxis 13 - 5 1/4" 13MB capacity	795.00
Pyxis 27 - 5 1/4" 27MB capacity	1225.00

*** 1 year warranty ***

WINCHESTER SUBSYSTEMS**MEDIA DISTRIBUTING**

MD-10 - 11MB capacity	2695.00
MD-20 - 22MB capacity	3595.00

(For Z-80, CP/M, IBM PC systems)

TERMINALS**AMPEX ADDS VIEWPOINT****Call for prices****AMPEX**

D-125 Green phosphor	499.00
D-150 Green phosphor	610.00
D-175 Green phosphor	625.00

(Amber phosphor option available)

QUME

QVT-102 Green phosphor	595.00
QVT-103 Green phosphor	749.00
QVT-108 Green phosphor	749.00

PRINTERS**QUME**

Sprint II - 40 CPS Daisy wheel	1395.00
--------------------------------	---------

OKIDATA PRINTERS**Call for prices****MONITORS****TAXAN**

KG-12N-U 12" Green phosphor hi-res.	149.00
KG-12N-UY 12" Amber phosphor hi-res.	159.00
RGBVISION-I 12" RGB color medium-res.	359.00
RGBVISION-III 12" RGB color hi-res.	629.00

**(408) 438-5454****SUPPLIES AND ACCESSORIES ALSO AVAILABLE****DEALER INQUIRIES INVITED****TERMS: COD, CASH WITH ORDER, MASTERCARD, VISA****FREIGHT CHARGES WILL BE ADDED TO ALL ORDERS**

most complex constructions without error or complaint. The company has shown steady progress in upgrading the product and adding preplanned enhancements. The documentation sets such a high standard of comprehensive excellence that others don't even come close. Only the function library is slightly lacking, and additional functions for sorting, randomizing, and ASCII/numerical conversion would be icing on the cake.

A full implementation of the C language, the Lattice compiler produces code only for the small memory model, although versions for the compact and big models are in use at test sites. A command-line option allows inline generation of 8087 floating-point code, but in the review compiler, library floating-point routines in 8087 format were substituted. Another command-line option enables you to intersperse C source code in the object module disassembler output, a step toward a planned high-level symbolic debugging package.

The few extensions to and variances from the C standard are worth noting. Only one copy of identically written string constants is generated by this compiler, although Kernighan and Ritchie state that all strings are distinct even when identical. Multiple character constants are allowed. Comments nest by default. Identical names may be used for members in different structures because the specific structure being referenced determines which member name (and corresponding offset and attributes) is intended.

The Lattice manual is logically organized and complete in its documentation of compiler libraries and assembly-language interface. The in-depth treatment of the relationship between the Lattice implementation and the C standard is especially welcome to the serious user. It lists variances and clarifications in order, with numerical reference to the corresponding section of the standard. The compiler's 90 error messages are fully and helpfully explained.

The object library includes additional functions for low-level memory

Compilers From Whitesmiths, Ltd. Are Earning Top Grades.



For users of PDP-11, VAX, MC68000, 8080, or 8086 CPUs, Whitesmiths' C Compilers are quite a step above average.

The compilers offer a wide range of desirable features. Like dependable and proven code. Flexibility. Ease of use. Portability. An incredible number of cross support options (now including support for the DEC and IBM PCs). An extensive portable library, with a new set of UNIX-

style functions to aid migration. And, of course, our optional Pascal Translator as well.

With our compilers, you get all this plus affordability. Prices start as low as \$550 for C Native Compilers, \$1100 for Cross Compilers. Pascal plus C Native Compilers cost \$700, Pascal plus C Cross Compilers cost \$1400. And our new "licensing under copyright" eliminates end-user licenses, thereby

lowering OEM costs and simplifying software distribution.

When it comes to Whitesmiths' compilers we are sure you'll agree: we are crafting software that is in a class by itself.

To find out how you can make our compilers work for you, write

Whitesmiths, Ltd.,
97 Lowell Road, Concord,
MA 01742. Or call (617)
369-8499, Telex 951708
SOFTWARE CNCM.



Whitesmiths, Ltd. Software Craftsmen

UNIX is a trademark of Bell Laboratories; PDP-11 and VAX are trademarks of Digital Equipment Corporation; MC68000 is a trademark of Motorola Inc.
Distributors: Australia, Fairway Pty Ltd., P.O. B. 224, Hurstville, NSW 2220 (612) 579-6100; Japan, Advanced Data Controls Corp., Chiyoda-ku, Tokyo (03) 263-0383; United Kingdom, Real Time Systems, Newcastle upon Tyne (0632 75313)

Name

Quantum C compiler

Type of Software Package

C programming language compiler bundled with multitasking operating system

Manufacturer

Quantum Software Systems Inc.
7219 Shea Ct.
San Jose, CA 95139
(408) 629-9402

Price

\$650 including operating system and utilities

Format

5¼-inch double-density single-sided IBM PC-compatible QNX format floppy disks

Type of Compiler

Produces assembly language

Computer Needed

IBM PC running QNX with two single-sided disk drives and a minimum of 128K bytes of RAM; 8087 coprocessor required for floating point

Documentation

186-page loose-leaf manual plus operating system documentation in two cloth binders

Audience

Systems and applications software developers, C programmers

Name

Supersoft C compiler version 1.1.3

Type of Software Package

C programming language compiler

Manufacturer

Supersoft Inc.
POB 1628
Champaign, IL 61820
(217) 359-2112

Price

\$500

Format

5¼-inch double-density single-sided IBM PC-compatible PC-DOS or CP/M-86 format floppy disks

Type of Compiler

Produces assembly language

Computer Needed

IBM PC running PC-DOS or CP/M-86 with two single-sided disk drives and a minimum of 64K bytes of RAM; IBM Macro Assembler required for use

Documentation

80-page loose-leaf manual in vinyl binder

Audience

Systems and applications software developers, C programmers

Name

Telecon Systems C version 2.6

Type of Software Package

C programming language compiler

Manufacturer

Telecon Systems
1155 Meridian Ave., Suite 218
San Jose, CA 95125
(408) 275-1659

Price

\$200—compiler without floating point

Format

5¼-inch double-density single-sided IBM PC-compatible PC-DOS or CP/M-86 format floppy disks

Type of Compiler

Produces assembly language

Computer Needed

IBM PC running PC-DOS or CP/M-86 with two single-sided disk drives and a minimum of 96K bytes of RAM; IBM Macro Assembler required for use

Documentation

21-page loose-leaf manual

Audience

Systems and applications software developers, C programmers

management, direct console I/O, and sophisticated string handling by pattern matching, parsing and symbol and token extraction are provided. An optional \$150 library, whimsically named "C Food Smorgasbord," provides a complete fixed and floating-point BCD (binary-coded decimal) arithmetic package with 16 significant-digit accuracy, an extensive series of direct device I/O routines, and a terminal-independence package providing the programmer with access to a variety of predefined existing terminals using ANSI X3.64 standard conventions. Built-in facilities let you add new terminals.

Quantum C, nearly a full Unix version 7 standard compiler, is an integral part of a complete multitasking operating system that supports up to 16 users and 250 simultaneous tasks and includes a large number of Unix-

like features such as hierarchical file structure with multilevel file security, device-independent I/O with mountable disk-resident drivers, and a complete shell command structure including inter-task pipes.

Quantum C has far too many special features and programs to explain in this article. One highly innovative feature worth mentioning, however, is that it shares the last three stages of code generation and assembly with optional FORTRAN 77, PC-compatible BASIC, and extended Pascal compilers, allowing separate compilation and cross-linking of modules from any of these different languages into one executable file. The four languages share a single extensive series of subroutine libraries; all require the 8087 coprocessor for floating-point calculations and all employ the same assembler (which may be used separately) and linking loader. Full exter-

nal communications and PC-DOS two-way file transfer are supported. The libraries, with over 150 subroutines to interface to all capabilities of the operating system, also include math support for exponential and logarithmic functions and trigonometrics, including hyperbolics and inverses.

The C compiler supports enumerated data types and allows in-line assembly language insertion via the #asm directive. It does not currently support initialization of auto variables, bit fields, or expressions following #if. Structures are initialized as if they were int arrays, and braces may not be nested in initializations. All of these features will be supported in the next major release.

All Quantum parsers support 64 significant characters in variable names. I/O redirection is supplied by the underlying operating system and thus is available to all programs in all

Innovative technology brings you quality color printing

for only \$599

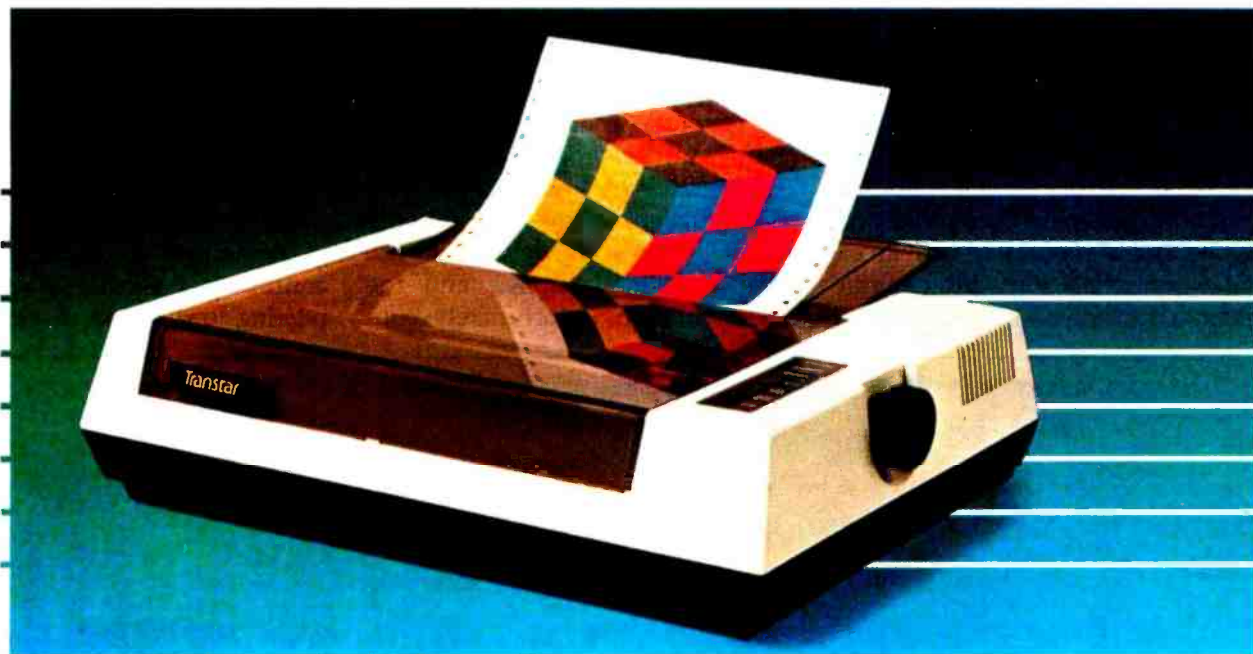

The technology of the all-new Transtar 315 color printer revolutionizes color impact printing! Unlike old-fashioned printers needing multiple passes with pins to print color, the Transtar 315 employs an innovative 4-hammer print head to allow 7 colors and more than 30 shades to be printed in a single pass!

A unique 4-color diagonal ribbon maximizes the efficiency of the 315's color imaging and enhances its simple reliability. Built by Seikosha, the most experienced manufacturing company of the famous Seiko group, the Transtar 315 is available now and has been designed to be compatible with the IBM, Apple II/IIe and Franklin personal computers. An optional PICS card also allows Apple and Franklin users to simply depress the 315's "copy" button to print any high- or low-resolution screen without exiting a program!

Transtar is bringing the technology of tomorrow to you today. Your future in color printing is only \$599 away.

Transtar

P.O. Box C-96975, Bellevue, Washington 98009

Circle 394 on Inquiry card.

languages. Kernel interface is possible on two levels, by software interrupts or message passing. Memory allocation is according to a system-specific model, with an initial configuration, similar to the small model, defaulting to a low-memory code segment with the remaining two allocatable segments concatenated immediately above. Direct segment-register usage manipulation by the programmer is allowed. In addition, the C parser recognizes the @ symbol as a pointer reference in the same manner as * pointers but as a reference off the base value of the ES segment register rather than the DS register used in normal C pointer reference.

This compiler produces fast, compact code for its host operating system and supports some highly innovative features. If it were available for more widely used systems, it could be generally recommended, but because it is bundled with an extensive discrete software environment, a decision on its merits or use

must be based on the entire operating system, not just the compiler alone. While I like the Quantum development environment—especially on a hard disk where command file access is reasonably short—full evaluation of this system is impossible here. It is worth noting that, while the system contains many powerful commands, programs, and utilities, the user pays a considerable price, in terms of performance, for the multitasking and multiuser capabilities. Potential users should anticipate some actual need for these capabilities.

The operating system and C compiler are accompanied by two manuals. Their structure provides for functional coverage of all aspects of the system, but their style assumes the user has considerable knowledge of the kind of programs provided. The libraries are given comprehensive alphabetized coverage, but only 16 small pages are devoted to the details of the compiler, and the documentation unfortunately con-

tains no indexes.

Supersoft C is one of a related series of products said to be available for any host-target combination from 8080, Z80, 8086, and Z8000 microprocessor families. Current operating systems supported are said to include the versions of CP/M and MP/M for both the 8080 and 8086 processors, MS-DOS, Unix, Xenix, and Central Data's ZMOS. The subroutine library is supplied in both source and object forms, and the package contains five sample programs.

In relation to the standard, the Supersoft implementation lacks long, double, and float data types, static and typedef storage class specifiers, bit-fields, and initializers on declaration. No parameters are allowed to #define macroinstructions, and the preprocessor does not support any conditionals, but #asm and #endasm are included to allow in-line assembly language.

The Supersoft documentation, a confusing pastiche of fragments relating to different processors and

The Most Promising Duet For An Orchestra.

Our duet is perfect for a single user system.

The same duet performs even better in a multi-user orchestra.

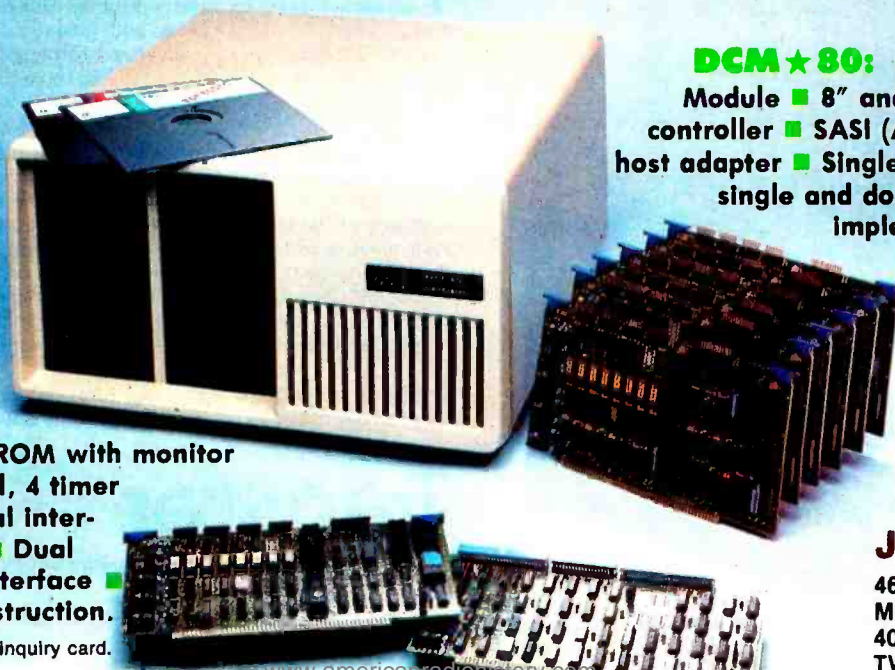

MEM 80:

- S-100 Single Board Computer
- Single or multi processor capability
- Programmable master or slave selection
- Redundant processor manipulation
- 4MHz Z80A or 6MHz Z80B CPU
- 64K RAM and 2K EPROM with monitor
- 2 serial, 2 parallel, 4 timer ports
- Bi-directional inter-processor channel
- Dual mode serial ports interface
- Multi-layer PCB construction.

\$495. Circle 218 on Inquiry card.

- DCM 80: S-100 Disk Controller Module
- 8" and/or 5 1/4" floppy disk controller
- SASI (ANSI, SCSI) hard disk host adapter
- Single and double density, single and double side
- Software implementation on CP/M 2.2 and TurboDOS!

TM of Digital Research, Inc.
TM of Software 2000, Inc.

\$345.



JC SYSTEMS

469 Valley Way
Millitas, CA 95035
408-945-0318
TWX#910-381-7041

Taxan monitors when precision counts

Dedicated to quality and precision, TAXAN offers a complete line of monitors including green and amber, ultra-high resolution monochrome, plus medium and high resolution RGB monitors.

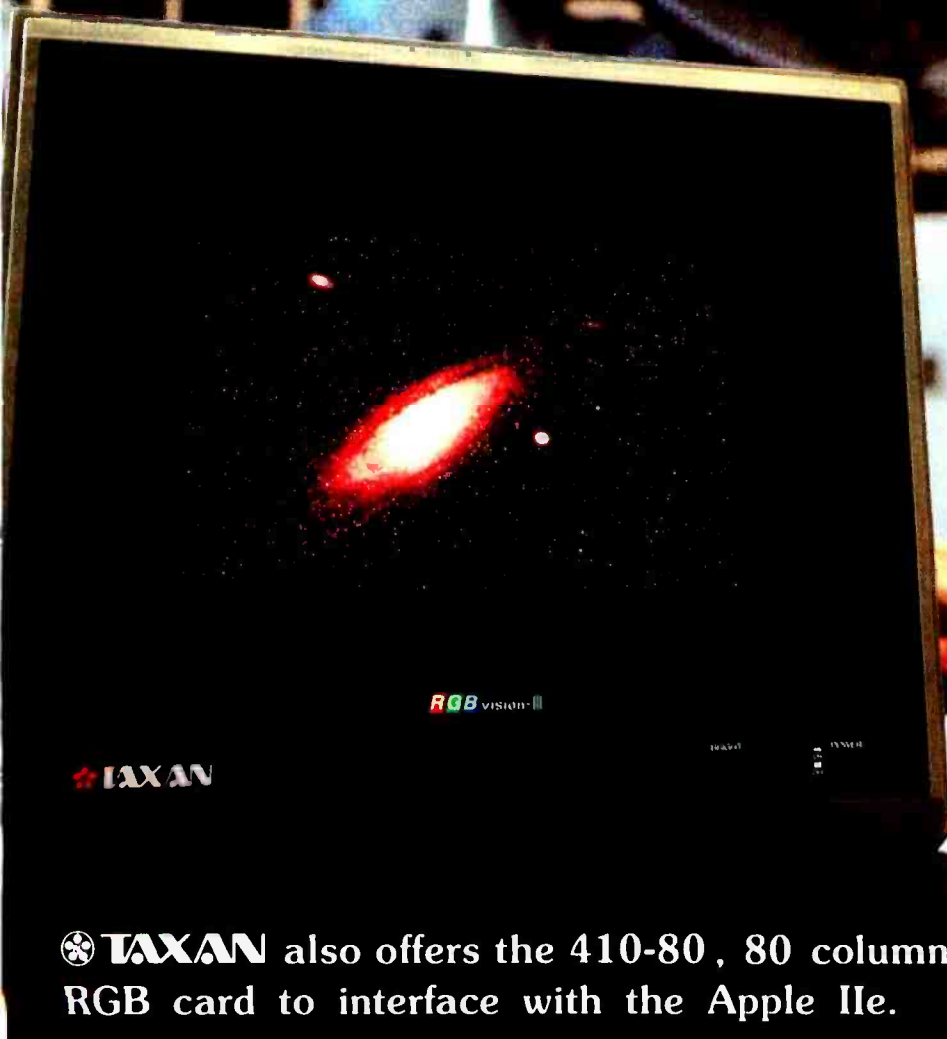

RGB vision III

TAXAN

⊗ TAXAN also offers the 410-80, 80 column and RGB card to interface with the Apple IIe.

⊗ TAXAN monitors stand alone.

See your local ⊗ TAXAN dealer, or call us for details!

⊗ TAXAN

TSK Electronics Corporation
18005 Cortney Court
City of Industry, CA 91748
(213) 810-1291

Circle 399 on Inquiry card.

operating systems, was a factor in making the Supersoft compiler the most difficult of the nine to use. Files that do not exist on the supplied disks are allocated whole chapters, and the files that do exist are mentioned only in passing, if at all. In the PC-DOS version I examined, the operating-system-related documentation was mainly concerned with CP/M, and its instructions were quite misleading. Run-time memory structure was only one of many useful items the manual neglected to cover, although an examination of the compiler's output shows the default to be the small model.

This software consistently took the longest time to compile the largest executable files of any compiler evaluated. In spite of the size of the executable file, facilities for run-time I/O redirection were not included. The run-time package did, however, produce a copyright message each time the user's program executed. Execution times for the code produced were consistently in the bottom third

of the nine compilers, with particularly poor results in pointer intensive and integer math operations. In light of the poor documentation and poor performance in terms of compile time, code size, and execution times, the software and documentation I received do not warrant consideration for serious use.

The Telecon 8086/88 C compiler, a product of Telecon Systems, will be obtainable for any combination of these host and target environments: 6809 (Flex, Uniflex, OS-9), PDP-11 (RT-11, RSX-11), 8080/Z80 (CP/M), 8086/88 (PC-DOS, CP/M-86). Priced at \$200, the package includes, in addition to the compiler, the standard I/O library in both source and object form, the `stdio.h` header file, and 21 pages of loose-leaf documentation. A floating-point library (not yet available) for the 8088 will cost about \$150.

The compiler accepts the full C language, and while the manual claims full Unix version 7 compatibility,

potential users should note the lack of support for enumerated data typing and structure assignment. Register declarations are treated as if they are automatic. Compiler I/O can be redirected, and C source code may be optionally interspersed with the assembly-language output as comments. Other command-line switches allow the generation of absolute addressed output (the default is relocatable), preprocessor macroinstruction expansion only, or run-to-locate errors only. The compiler's 36 error messages are cryptic.

Documentation is sparse, and, in relation to the other compilers, incomplete. The description of interfacing methods to external routines, in an attempt to cover all supported processors, is too general. No mention is made of how the compiler allocates memory or manipulates the segmentation of the 8088 processor, although code examination reveals that the compiler supports the small memory model as default. Custom-segmentation schemes can be implemented



MegaPlus & I/O-Plus 2 The Ultimate Expansion for IBM PC or XT

The AST Research MegaPlus™ has three functions standard: Parity checked and fully socketed memory up to 256k in 64k increments; clock/calendar with battery back-up for automatic loading of time and date when the computer is turned on, and asynchronous communication port (RS232C serial) which can be used as COM1 or COM2, (DTE for a printer, or DCE for a modem). Also included is SuperDrive™ "electronic disk" software. This program builds "disk drives" in memory which access your programs at the speed of RAM memory. And you get SuperSpooler™, print spooling software.

Options include a 100% IBM compatible parallel printer port (can be configured as LPT1, or LPT2), and a second RS232C asynchronous port (COM1 or COM2) The MegaPak™ option plugs into your MegaPlus "piggyback" style to give you an additional 128k or 256k of memory.

I/O-Plus 2, is the answer for those who don't need additional memory but would like all those other multi-function board features. The I/O-Plus 2 comes standard with a clip-on battery powered clock/calendar, an asynchronous communication port (RS232C serial), SuperDrive™ electronic disk, and SuperSpooler™ print spooling software.

Optional is a second asynchronous port (DTE, or DCE), a parallel printer adapter, and the best game paddle adapter on the market. It is an IBM standard game port, but it can also use Apple compatible paddles and joysticks.

Both boards come with a one year factory warranty and the Qubie' satisfaction guarantee. If for any reason you are not satisfied with the performance of your board within thirty days of purchase, you may return it for a full refund, including the postage to return it.

TO ORDER BY PHONE:
In California (805) 482-9829
Outside California TOLL FREE (800) 821-4479

PRICES:
I/O-Plus 2™ with Clock/calendar, asynchronous communication adapter, SuperDrive™ and SuperSpooler™ - \$129
MegaPlus™ with memory, clock, async, SuperDrive™ and SuperSpooler™ - \$289

OPTIONS:

64k upgrades, installed and tested	\$50
Parallel Printer Port	\$35
Second Asynchronous Port	\$35
Game Adapter (I/O-Plus 2 only)	\$35
MegaPak™ with 256k of Memory	\$349
with 128k of Memory	\$249
2 year extended warranty	\$50
ConnectAll Cable Bracket	\$19
Cable to Parallel Printer	\$35
Cable to Modem or Serial Printer	\$25
Comprehensive Diagnostics Programs	\$10
SUPERWRITER by Sorcim	\$179
SUPERCALC™ by Sorcim	\$159
dBASE II by Ashton-Tate	\$419

SHIPMENT:
Normal shipment is day after receipt of order. We pay UPS surface charges, 2 day air service \$5 extra.

QUBIE' DISTRIBUTING
4809 Calle Alto, Camarillo, CA 93010
European Inquiries:
129 Magdalen Rd., London, SW18, England
Phone (01) 870-8899

The new COMPAQ Portable Computer. IBM compatibility to go.

Simple, isn't it? The COMPAQ™ Portable Computer can do what the IBM® Personal Computer does. To go.

It runs all the popular programs written for the IBM. It works with the same printers and other peripherals. It even accepts the same optional expansion electronics that give it additional capabilities and functionality.

There's really only one big difference. The COMPAQ Computer is designed to travel.

Carry the COMPAQ Computer from office to office. Carry it home on the weekend. Or take it on business trips.

If you're a consultant, take it to your client's office.

If you use a portable typewriter, you can use the COMPAQ Computer as a portable word processor instead.

If your company already uses the IBM Personal Computer, add the COMPAQ

you'd probably need to buy an additional display screen because the built-in screen is too small for certain tasks, like word processing. The COMPAQ Computer's display screen is nine inches diagonally, big enough for any job, and it shows a full 80 characters across. And the built-in display offers high-resolution graphics and text characters on the same screen.

The bottom line is this. The COMPAQ Computer is the first uncompromising portable computer. It delivers all the advantages of portability

In the standard configuration, the COMPAQ Computer has three open slots for functional expansion electronics as your needs and applications grow. It accepts standard network and communications interfaces including ETHERNET™ and OMNINET™.

If you're considering a personal computer, there's a new question you need to ask yourself. Why buy a com-

puter that isn't portable?

For more information on the COMPAQ Portable Computer and the location of the Authorized Dealer nearest you, write us. COMPAQ Computer Corporation, 12330 Perry Road, Houston, Texas 77070. Or call 1-800-231-9966.

without trading off any computing power capability.

And what do those advantages cost?

Nothing.

The COMPAQ Portable sells for hundreds less than a comparably equipped IBM or APPLE® III. Standard features include 128K bytes of internal memory and a 320K-byte disk drive, both of which are extra-cost options on the IBM. Memory and additional disk drive upgrades are available options to double those capacities.

Portable as a mobile unit that can use the same programs, the same data disks, and even the same user manuals.

There are more programs available for the COMPAQ Computer than for any other portable. More, in fact, than for most non-portables. You can buy them in hundreds of computer stores nationwide, and they run as is, right off the shelf.

With most other portables

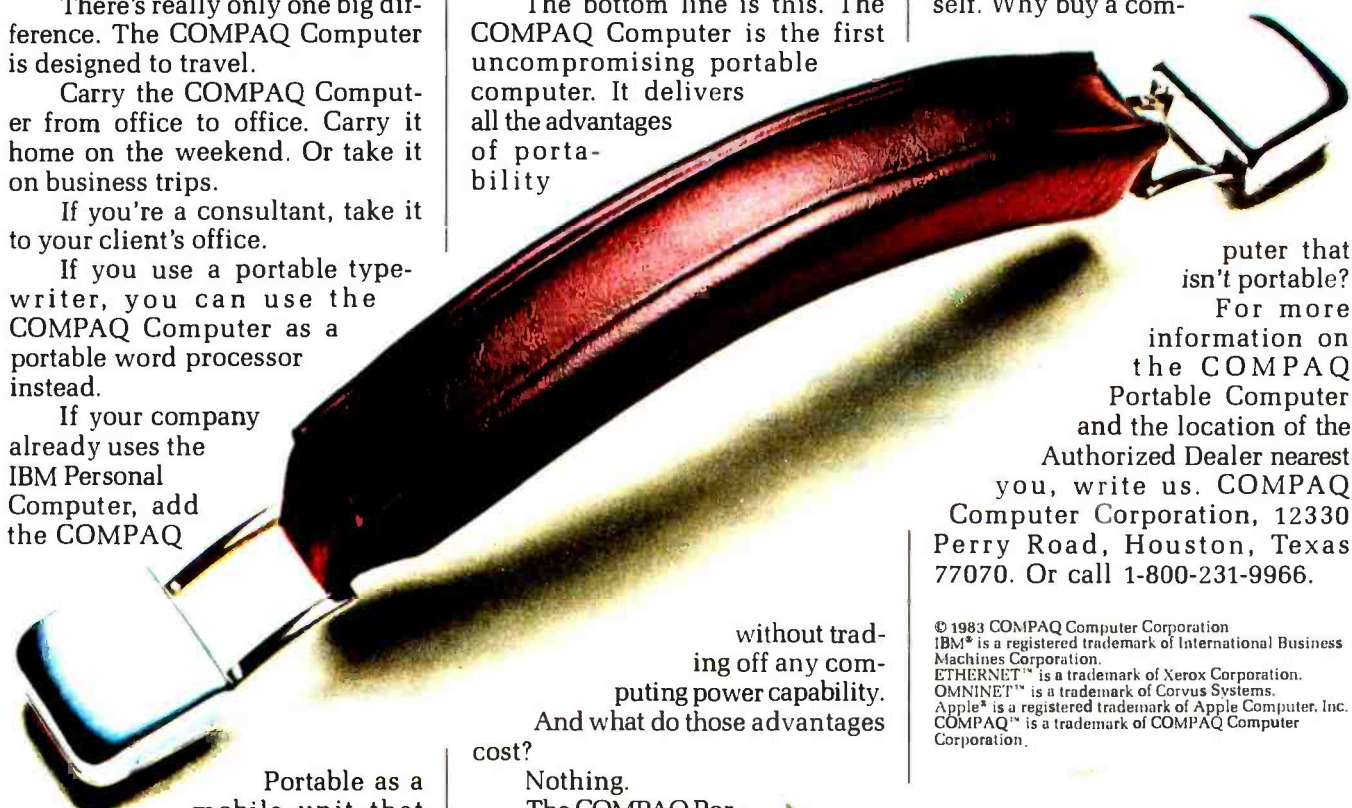

COMPAQ™

PORTABLE COMPUTER

The most computer you can carry Circle 81 on Inquiry card.

STANDARD UNIX SYSTEM CALLS REPLACED BY C LIBRARY SUBROUTINES

	c-systems	Caprock	CI-C86	DeSmet	Intellect	Lattice	Quantum	Supersoft	Telecon
brk								X	
close	X		X	X		X		X	
creat	X		X	X		X		X	
..._exit			X			X			
exit	X	X	X	X		X	X	X	X
lseek	X		X	X		X			
open	X		X	X		X		X	
read	X		X	X		X		X	
sbrk	X		X			X		X	
tell	X		X						
unlink	X		X	X		X		X	
write	X		X	X		X		X	

STANDARD C LIBRARY SUBROUTINES

	c-systems	Caprock	CI-C86	DeSmet	Intellect	Lattice	Quantum	Supersoft	Telecon
abort			X				X		
abs						X	X	X	
atof			X				X		
atoi	X		X				X	X	
atol							X		
calloc			X	X		X	X		
free			X	X		X		X	
longjmp									
malloc			X	X		X	X		
qsort			X						
rand				X			X	X	
realloc			X	X			X		
setjmp									
srand				X				X	

STANDARD C LIBRARY STRING FUNCTION SUBROUTINES

	c-systems	Caprock	CI-C86	DeSmet	Intellect	Lattice	Quantum	Supersoft	Telecon
strcat	X		X			X	X	X	X
strcmp	X		X			X	X	X	X
strcpy	X		X	X	X	X			X
strlen	X		X			X	X	X	
strncat			X					X	
strncmp			X						
strncpy			X					X	
index			X					X	
rindex			X					X	

Table 3: Standard library functions included with each of the compilers. In the table, an X indicates the function is available, an ! (exclamation point) means the function varies significantly from the standard, and a blank means the function is not included. Most compilers also include additional, nonstandard functions.

using assembly language.

The entire Telecon object library is entered to the linker in line with the user's program, rather than as a library to be searched through for only the appropriate code. Although this strategy ensures a consistent method across the range of processors supported, these files mean an additional 6K bytes at the least to any program. Fortunately, the source code is included, so the experienced

programmer can separate what will be used from the remainder and recompile for minimum program size. Unfortunately, the library contains only a bare minimum of subroutines.

The Telecon compiler is simple and straightforward to use. Compile and link times in both memory disk emulator and floppy-disk environments were somewhat longer than the median, and incremental code size and execution speed were only average.

For some reason, this compiler crashed when attempting to compile a function consisting solely of an empty for loop, used to factor out looping times from measures of other compiler performance facets, forcing the system to be reloaded. The Telecon compiler is relatively efficient at function calling, but it ranked behind the others in integer math, local-variable access, and pointer operations. I haven't seen or used the

STANDARD C LIBRARY CTYPE CHARACTER MACROS

	c-systems	Caprock	CI-C86	DeSmet	Intellect	Lattice	Quantum	Supersoft	Telecon
isalnum	X		X			X		X	
isalpha	X		X	X		X	X	X	
isascii			X			X		X	
iscntrl			X			X		X	
isdigit	X		X	X		X	X	X	
islower	X		X	X		X	X	X	
isprint			X			X		X	
ispunct			X			X		X	
isspace	X		X	X		X	X	X	
isupper	X		X	X		X	X	X	
*tolower	X		X	X		X	X	X	
*toupper	X		X	X		X	X	X	

*Conversion functions

STANDARD C LIBRARY stdio SUBROUTINES

	c-systems	Caprock	CI-C86	DeSmet	Intellect	Lattice	Quantum	Supersoft	Telecon
flush	X		X			X	X	X	
fclose	X	X	X		X	X	X	X	X
feof			X			X	X		
ferror			X			X			
clearerr			X			X			
fileno						X			
fopen	X	X	X	X	IX	X	X	X	X
freopen						X			X
fread			X						
fwrite			X						
fseek	X		X			X	X		
ftell	X		X			X			
rewind						X	X		
getc	X	X	X	X	X	X	X	X	X
getchar	X	IX	X	X	IX	X	X	X	
fgetc			X			X			
getw	X		X	X				X	
gets	X	IX	X	X	X	X	X	X	X
fgets	X		X	X	X	X	X	X	X
printf	X		X	X	X	X	X	X	X
fprintf	X		X	X	X	X	X	X	X
sprintf	X		X	X	X	X	X	X	X
putc	X	X	X	X	X	X	X	X	X
putchar	X	IX	X	X	IX	X	X	X	
fputc			X			X			
putw			X	X				X	
puts	X	IX	X	X	X	X	X	X	X
fputs	X		X	X	IX	X	X	X	X
scanf	X		X	X	X	X	X	X	X
fscanf	X		X	X	X	X	X	X	X
sscanf	X		X	X	X	X	X	X	X
ungetc	X		X			X	X	X	

other code generators or compilers in this series, but I think the main reason for choosing this software would be its cross-compilation facilities. Because the output is assembly language, small applications could always be hand optimized for speed and compaction.

Conclusions

Evaluating the nine compilers in several broad categories may shed

light on their main strengths and weaknesses. Software floating point is supported by Computer Innovations, DeSmet, Lattice, and Quantum. Compilers that use the 8087 are Computer Innovations, DeSmet, and Quantum, with the Quantum compiling in-line code and others making function calls to library subroutines. C-systems allows use of more than 128K bytes of memory, although versions of several others

that do so are imminent. Run-time library source code is included in systems from Caprock, Computer Innovations, Supersoft, and Telecon. Under PC-DOS, the c-systems, Caprock, Supersoft, and Telecon compilers require ownership of the IBM Macro Assembler. The compilers from Caprock, Intellect Associates, and Supersoft were unable to compile several programs in the test group. C-systems, Caprock, DeSmet,

Unix Version 7 Extensions to the C Language

The two significant Unix version 7 extensions to the C language—enumerated data types and structures as function arguments—need further elucidation because no readily available source of information about them exists. Because Kernighan and Ritchie's standard text made provisions for both of them, they are likely to be more widely used in the future.

Enumerated Data Types

This powerful extension, shared with the other ALGOL-derived languages—Pascal (as enumerated scalars), Ada, and Modula-2—allows the user to specify named, ordered, and sequential data sets. By default, each newly created set member is assigned, in sequence, an integer value, ascending from 0 in increments of 1. The keyword `enum` is used to define the new data type, declare the set members, and initialize those members to specific values. For example, to specify a sequential set of constants that may appear anywhere an integer constant is allowed,

```
enum direction { north, east, south, west };
enum opcode { clc, stc, cli, sti, cld, std };
enum workday { monday, tuesday,
               wednesday, thursday, friday };
```

Constant integral values may be assigned, at declaration or later, to any

of the set elements as:

```
enum direction { north = 'N', east = 90,
                 south = 180, west = 270 };
```

If any set member is assigned a value, the remaining members progress from there. In the 8088 instruction set, for example:

```
enum opcode { clc = '0xf8', stc, cli, sti, cld,
              std };
```

Having previously defined the data type `workday`, it can then be used in a declaration such as:

```
enum workday today; /* today can have one
                    of five possible values */
today = tuesday; /* assigns a set
                  element to the new variable */
```

An example of illegal assignment:

```
today = south; /* south is not one of the
                five valid choices */
```

The possible applications of this technique are extensive and can lead to dramatic improvement in the clarity and readability of C programs.

Structures as Function Arguments

Function calling with a structure as an argument causes a copy of the entire struc-

ture to be passed to the function. Similarly, with functions returning structures, a copy of the entire structure is passed back to the caller. This extension allows normally global data to assume a temporarily local nature, thus optionally isolating the actions of a function or series of functions on a structure.

For example, if `struct1` has been declared a structure, then `&struct1` is a pointer to it. Calling a function with a pointer to a structure has been the usual way of passing this data type as a parameter. It looks like this:

```
function(&struct1);
```

In compilers that implement the new version 7 extensions, to actually pass the entire data structure, rather than pass a pointer to the structure's location in memory, simply omit the `&`:

```
function(struct1);
```

Some compilers accept the structure name without `&` while still passing only a pointer, and they may or may not give a warning message telling what's going on. Obviously this can lead to trouble if you then transport that code into a true Unix version 7 environment.

Quantum, and Supersoft provide support for mixing in-line assembly language with C code. The Computer Innovations and Lattice compilers provide command-line options to ease translation from 8080 C source code written for the ubiquitous BDS C compiler, in which all variables are extern or auto.

Three broad classes emerged in performance, price, and user interface. At the top, "superior quality, but expensive and unsuited to the beginner" are the Lattice and Quantum compilers. Just below this category is software that offers particular individual values and features. These might be called "good-quality." In this category I would include the c-systems, Computer Innovations, DeSmet, and Telecon software. The last category, "other," includes

Caprock, Intellect Associates, and Supersoft.

My personal preferences are Lattice C in the top category for its quick compile and execution times, small incremental code, best documentation and consistent reliability; DeSmet in the good category for its combination of fast compiling and executing code, good documentation, extraordinary price/performance ratio and many included utilities; and Caprock in the third category because it's a good learning tool for a reasonable price. C-systems, in the "good" group, is also attractive for its innovative debugger, PL/M compatibility mode, and memory-usage extensions. The company has been working hard to improve its product since it was released, and I would expect performance upgrading follow-

ing the completion of their implementation. The DeSmet compiler would be rated at the top except for preprocessor problems and the newness of the producer, making the extent of future support and improvements unpredictable.

These nine C compilers are part of the largest array of compilation tools available for any single programming language on the IBM PC. ■

Ralph A. Phraner (516 Shrader St., San Francisco, CA 94117) is an independent microcomputer product-development consultant currently working with the C and FORTH programming languages.

Acknowledgments

I'd like to thank the compiler manufacturers who made their products available for my evaluation and those compiler authors who freely shared their insights and experience with me.



FOR APPLE USERS

MITAC is the leading supplier of add-on disk drives for APPLE II computers. The MITAC add-on line-up includes 5¼" standard/half height floppy disk drives and 5¼" 5MB/10MB Winchester disk drives. MITAC disk drives are engineered and built to the most demanding industrial standards of reliability, availability and maintainability. Passing through the crucial 48 hours of burn-in and a series of hardware/software tests, you are assured of MITAC's superior quality.

MITAC disk drives are designed to be compatible with the APPLE II[®], II Plus[®], and IIe[®] computers. All software developed under Apple DOS, CP/M[®], PASCAL[®] can be run on the MITAC AD-X disk drives without modification.

For U.S.A and CANADA Inquiries
Please Call Collect (408)988-0258,

AMERICAN *mitac* CORP

P.O. Box D Santa Clara, CA. 95055
Tel: (408) 988-0258 Telex: 9103382201 MECTEL

FOR IBM PC USERS

Business people needing storage, reliability, fast access and office automation will be impressed with MITAC MATE-V, X Winchester disk drives due to the unique, microprocessor-based cost-effective design. With built-in hardware capability, it checks and automatically corrects errors and this insures you of data integrity.

MITAC Winchester disk drives are designed to be fully compatible with IBM PC computers, all software developed under MS-DOS[®], CP/M-86[®], UCSD-p[®] systems can be run on MATE-V, X without modification.

* Registered trademarks of ©Apple Computers Inc
©Digital Research Inc. ©UCSD ©Microsoft
©Softech Microsystems

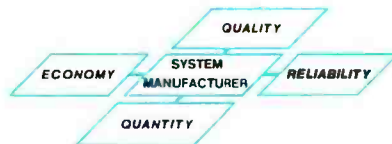

FULL LINES OF AD-ON DISK DRIVES

BRAND	MODEL	COMPATIBILITY		CAPACITY (FORMATTED)
		APPLE II	IBM PC	
MATE-I	AD-1	v		143.4KB
MATE-II	AD-2	v		143.4KB
MATE-V	AD-50A	v		5 MB
	AD-50 I		v	5 MB
MATE-X	AD-100A	v		10 MB
	AD-100 I		v	10 MB

MITAC is a system manufacturer. Add-on disk drives, office microcomputers, personal computers, video monitors, ASCII and Chinese terminals.

For International Inquiries Please Contact

***mitac* INC.**

3rd Fl., 75 Nanking E. Rd., Sec. 4,
Taipei, Taiwan, R.O.C.
Tel: (02) 713-6980; (02) 715-0940
Telex: 20261 MECTAC; 11942 TAIAUTO

Circle 21 on inquiry card.

“ADD UP TO 512K RAM, ASYNC AND SYNC COMMUNICATIONS, A CLOCK AND PRINTER SUPPORT-UP TO FOUR I/O PORTS IN JUST ONE SLOT?”

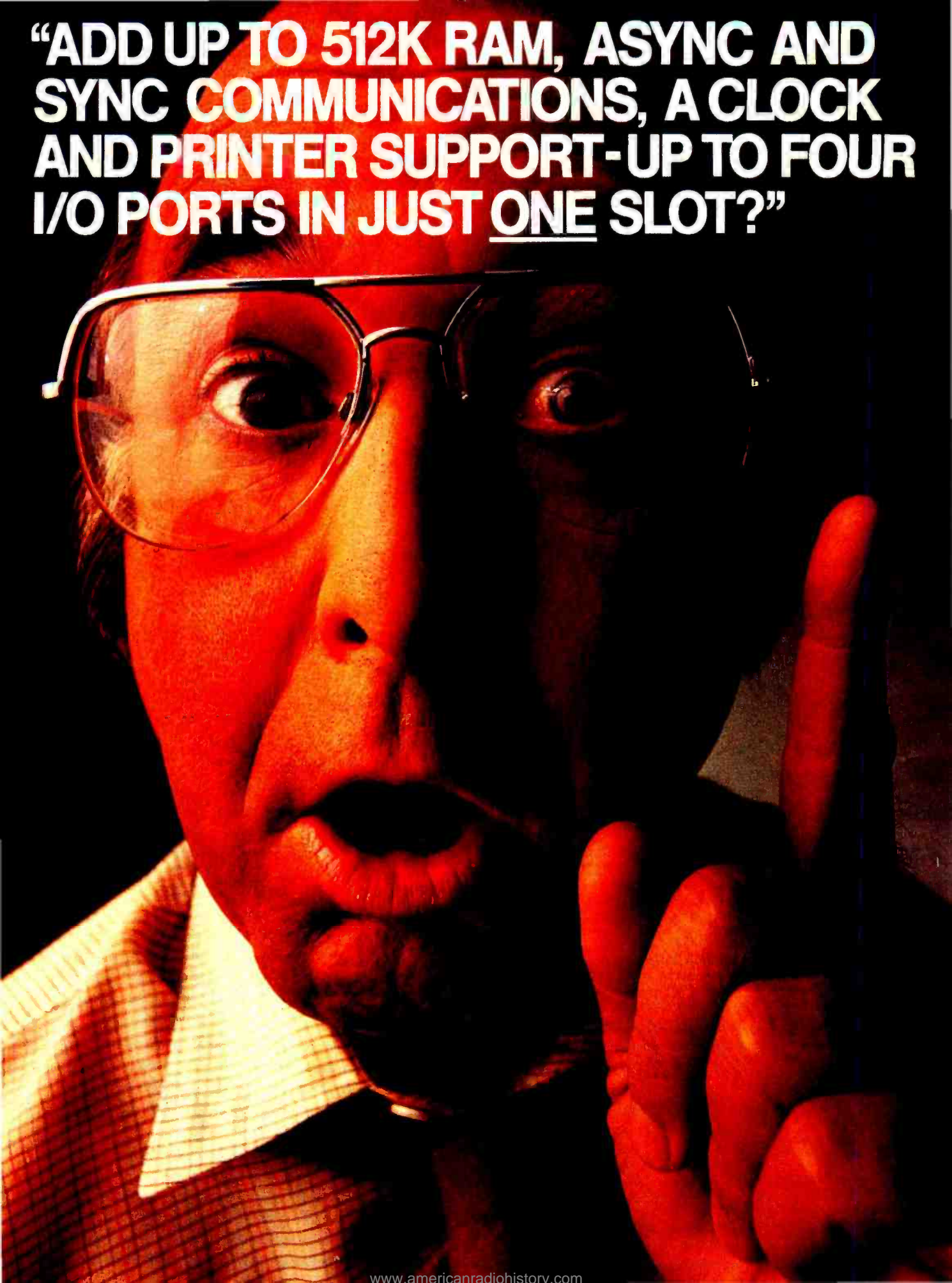

"YOU CAN WITH PERSYST."

The Persyst Time Spectrum. It's the most powerful and expandable multi-function PC board you can buy.

A Persyst Time Spectrum™ multi-function board can make any personal computer work better.

Whether you own an IBM PC or XT. Or the IBM compatible Compaq or Columbia.

There's even a Time Spectrum board for the Texas Instruments PC.

With Time Spectrum, you can combine up to six powerful functions—plus two advanced software programs—on just one board. And get performance and features like nothing else.

For the IBM PC, Compaq and Columbia, maximum capability in minimum space.

For example, Time Spectrum is the only multi-function board that lets you expand your IBM PC from 64K up to 512K RAM. Add a calendar clock. Add as many as two RS-232 asynchronous communications ports, or two synchronous and one asynchronous communications port. Plus print spooling and as much as 320K of RAM disk memory.

Up to four I/O ports—in just one slot.

How did we do it?

With the Cliffhanger™ A unique, RFI-shielded connector system that solves the problem of tying two or more I/O ports to peripheral equipment like a printer or modem, without consuming two or more slots.

And only Persyst has it.



The Time Spectrum Cliffhanger™. So ingenious, it's patented.

What's more, expansion functions can be plugged right onto the Time Spectrum board. Or added with Versapak™ piggyback modules. So you can add exactly the capability you need, when you need it.

Extra flexible expansion for the IBM XT.

For the IBM XT, Time Spectrum not only delivers exceptional one-board expansion capability, but extra flexibility, too.

First, we designed Time Spectrum so you can add the RAM you want without having to fill the memory rows on the XT mother board.

And with Time Spectrum plug-in expandability, you can continue to add functions as you add requirements.

Start with basic memory and a calendar clock. Then add another asynchronous communications port. Parallel printer port. Additional memory. Or any combination of functions.

With Persyst, the choice is yours.

And now, one-slot capability for your Texas Instruments PC.

Now there's even a Time Spectrum multi-function board for your TI PC. With it, you can add up to 512K RAM, two serial ports, calendar clock and light pen port—capability to handle even the most complex and difficult computing functions.

And still only consume one slot.

The Persyst Time Spectrum board.

Maximum expandability now. And quality and versatility so you can keep on expanding later.

See your IBM or TI PC dealer and insist on Persyst.

PERSYST™

Persyst Products, Personal Systems Technology, Inc., 15801 Rockfield Blvd., Suite A, Irvine, CA 92714. Telephone: (714) 859-8871. TWX: 467864.

Circle 313 on inquiry card.

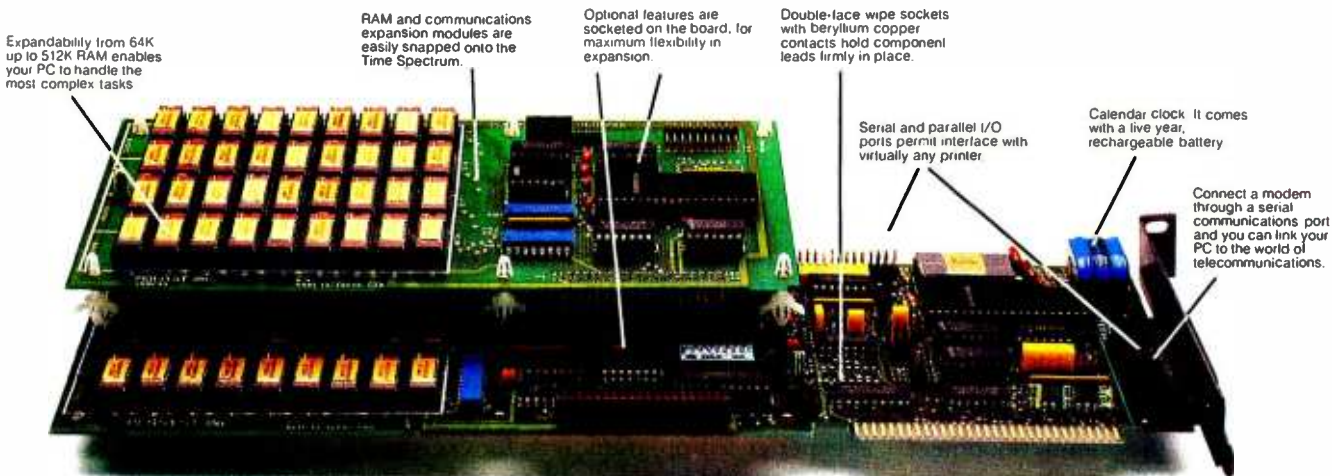

THE TIME SPECTRUM™ BY PERSYST.

Managing Software Development with C

Selecting a program-development environment that meets its users' needs

by Jason Linhart

Designing software for the rapidly changing personal computer marketplace is a complex task. But by carefully selecting a program-development environment, you can ease the job considerably. Choosing the development environment's major component, the programming language, from the many languages available today is difficult, but coming to grips with this problem early in the design cycle hastens the development of efficient, competitive programs.

The rapidly growing market for personal computer software is driven by constantly improving hardware technology that in turn raises users' expectations of software performance. As a result, developing software for this market requires careful understanding of users' needs and the ability to rapidly develop programs that meet these expectations.

This article will focus on how to select a program-development environment and choose a programming language that allows the most efficient use of program-development time. Note that the environment includes all the hardware and software

tools used in the process of developing programs: the programming language, the compiler, the text editor you use to compose programs, and the machine you use for development. The development environment also includes such factors as programming style and the availability of consultants.

Choosing an Environment

A good programming environment can affect programming ease and code quality more than you might imagine. An often quoted maxim about end-user applications applies equally to programmers' tools: if a system is comfortable and easy to use, you will use it more frequently and produce better work with it.

A programming environment should make programs easy to write; it should include a large assortment of useful tools and techniques to help ease the programming process at every step. And the tools should never be obstacles to the development process—error messages aimed at experienced programmers, for example, should be clear and concise.

A poor programming-environment

selection can limit marketing possibilities for the program. For example, licensing restrictions on the use of the development compiler's run-time library can prevent programs from being competitive with similar programs written on different systems. In general, environments aimed at producing programs for sale must not impose such disadvantages.

When you choose your programming environment, keep in mind that the development software should run on a variety of microcomputers. That way, you can use common, inexpensive development systems while developing your program on the target machine and at the same time keep in touch with the target machine's limitations and capabilities. Development software that runs on a variety of machines makes writing transportable applications programs easier. Indeed, to increase market potential, such programs should be transportable to many different microcomputers. The microcomputer industry changes quickly, and designing programs to be transportable increases their chances of running on the new hardware that

PKASO™

Printer Interface Family

**Welcomes the
New Apple IIe...
We work together.**



PKASO Interfaces come complete with Cable, Instructional Diskette and Comprehensive Manual.

The PKASO family makes you and your Apple Computer a master of text and graphics.

PKASO makes it easy to use the features of your printer—select character sizes, vary line spacing, even print in colors. Simple PKASO commands make these features usable from the keyboard or a program.

PKASO also adds features to your system. Press a few keys and get a snapshot "dump" of the image you see on the screen—text or graphics. Add new characters and symbols that you couldn't print before, using our SuperFont™ system. Add our new PipeLine™ printing buffer and your printer can take its time while you and your Apple move on to the next task. The PipeLine is a modular add-on to the standard PKASO board.

The PKASO interface is designed for Apple II and Apple III in all the popular configurations. It prints in full color on the IDS Prism Printer, and in striking black on C. Itoh, Centronics, Epson, IDS, NEC, and Okidata matrix printers

Circle 211 on Inquiry card.

NEW!

The IS Pipeline™ Printing Buffer with Random Access Printing stores paragraphs or pictures for printing in any order—any number of times!

- Universal—works with any parallel (Centronics style) computer/printer combinations.
- 8K to 128K Bytes of memory with data compression for efficient use of memory space.

Interactive Structures Inc.
146 Montgomery Avenue
Bala Cynwyd, PA 19004
Telephone: (215) 667-1713

will probably replace existing machines within three years.

A development environment should also be suitable for writing programs that are large, at least by microcomputer standards. Most systems won't constantly be used to generate programs with thousands or tens of thousands of lines, but an environment suited to such tasks is almost always adequate for writing small programs.

Choosing a Language

Selecting a programming language is the most fundamental step in the implementation of a programming environment. It is far simpler to change compilers, machines, text editors, or any of the other factors in the environment than it is to change the language in which a library of programs is written. The substantial investment in any code already written is lost if it must be translated into another language.

The first step in language selection is to choose between assembly lan-

guage and high-level languages. Assembly language can be thought of as a more readable version of the binary machine code that tells the processor what to do. High-level languages let you program for an abstract or theoretical computer that does not necessarily correspond to any particular physical computer.

Assembly language tells the machine what to do for each program step. A program written in assembly language can therefore run as fast as the machine is theoretically capable of operating. In contrast, a program written in a high-level language must be translated into machine code, typically by a compiler. The result of this compilation is never as tailored to the machine as it would be if an experienced assembly-language programmer had written the code. Programming in assembly language always results in faster programs, given sufficient programming effort.

The size of the finished program is under the direct control of the assembly-language programmer. A

compiler, on the other hand, translates a given program into a sequence of instructions that is not always the shortest possible route to the desired result. Because the programmer has no control over the compiler's translation operation, an assembly-language program can always be made smaller than a compiled program for a given task.

One major disadvantage of assembly-language programming is the large size of the source program. Assembly-language programs are 10 or more times larger in source-code form than their equivalent high-level language programs. High-level languages usually specify several machine instructions with a single statement, while an assembly-language statement specifies only one instruction.

Another drawback to programming in assembly language is that it generally introduces an additional level of complexity into the programming process. Assembly-language statements can often serve more than

GRAPHICS-PLUS an enhancement For Z19 Terminals from Northwest Digital Systems

- Tektronix² 4010 Compatible Graphics
- 512 Horiz by 250 Vert Resolution
- 80/132 Col and 24/49 Line Text Displays
- Seven Page Off-Screen Text Memory
- Menu-driven "Plain English" Set-up Mode
- 16 Programmable Keys- 128 Chars Each
- Optional Hardcopy Port
- Simple Field Installation

1 TM Zenith
2 TM Tektronix
3 TM DEC

GP-19 Upgrade for Z19 Terminal	\$ 849
Z19 Terminal With GP-19 Installed	\$ 1495

Northwest Digital Systems

P.O. Box 15288, Seattle, WA 98115 (206) 362-6937



GRAPHICS-PLUS is a field installable enhancement board for the popular Zenith¹ Z19 video terminal adding many powerful features found only on terminals costing much more. GRAPHICS-PLUS provides Tektronix² 4010 compatible vector drawing graphics, VT100³ compatible 80 and 132 column display formats, off-screen scrolling memory, programmable function keys, "Plain English" menu-driven Set-up mode, and a host of other enhancements. Installation can be accomplished within 15 minutes using only a screwdriver.

"Training? Call a computer school."

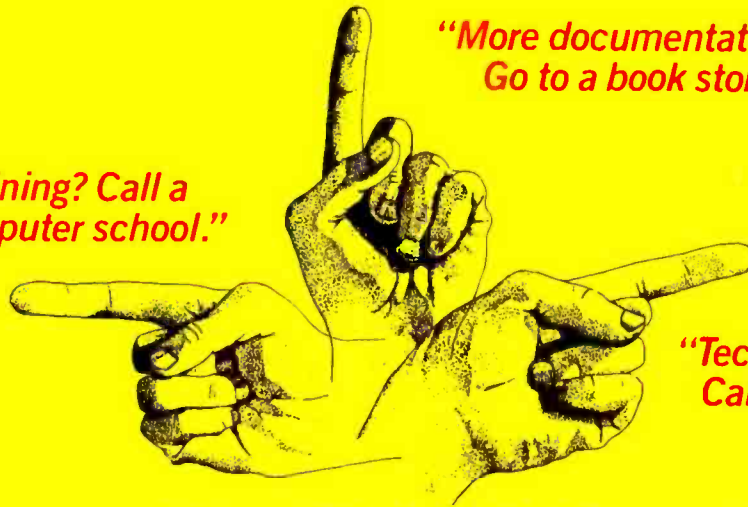

"More documentation? Go to a book store."

"Technical support? Call the publisher."

Interested in dBASE II™ or 1-2-3™? Beware The Dreaded Finger Pointers!

Sound familiar? Does your dealer turn into a "finger pointer" when you need help?

At SoftwareBanc we offer a complete system that doesn't stop when your software is delivered.

Careful Product Selection

Do you get bewildered by the endless lists of software you find in most ads? Let us be your quality control department.

We only sell the best programs on the market. After a thorough evaluation we chose dBASE II™ for data processing, and 1-2-3™ for financial management.

Our complete line of add-on products help you to continue to get the most from your software.

Expert Technical Support

When you buy software from us, you can rest assured that help is only a phone call away. Just call us at (617) 641-1235 for all the free support you need.

Money Back Guarantee

We are offering a 60 day money back guarantee on the following software: 1-2-3, dBASE II and ABSTAT. Call for details.

Free dBASE II™ User's Guide

Order dBASE II™ from us, and you'll receive a free copy of our dBASE II™ User's Guide. You can also buy the User's Guide first for only \$29, and then receive a full credit when you buy dBASE II.™

1-2-3™ & dBASE II™ Classes

Want more in-depth information about dBASE II™ or 1-2-3™? Attend a SoftwareBanc Seminar near you. Each session runs from 9 to 5, and costs \$175. Seminars are in lecture format with a custom sound & video system which is used to display taped interviews with prominent software personalities and sessions with various software programs.

Los Angeles
July 18-22

Anchorage
August 11-12

Washington, D.C.
Aug. 29-Sept. 2

New York City
September 19-23

Prices You Can Afford

†1-2-3™	\$399
†dBASE II™	\$479
†ABSTAT™	\$379
dBASE II™ User's Guide	\$29
DBPlus™	\$95
dGRAPH™	\$199
dUTIL™	\$69
dNAMES™	\$109
QUICKCODE™	\$199
TEXTRA™	\$60*

†No-risk 60 day money back guarantee

*Only available for IBM PC with MS-DOS.

Free Catalog

If you want to learn more about SoftwareBanc, call or write for our free product catalog.

SoftwareBanc

661 Massachusetts Avenue
Arlington, Mass. 02174

For technical support call:
(617) 641-1235

Dealer Inquiries Invited.

™ Manufacturer's trademark

Payment may be made by: MasterCard, Visa, check, C.O.D., money order. Mass. residents please add 5% sales tax. Add \$5.00 for shipping and handling. Prices subject to change.





For users of Apple, IBM, TRS/80, Atari, Commodore, Texas Instruments, and other brand name computers:

Here's the easiest way to buy quality diskettes at discount prices

Now you can get error-free double or single-side diskettes by IBM, Control Data, Maxell and Verbatim delivered to your door. For some of the lowest prices around.

You save because we ship huge volumes of magnetic media in boxes of 10.

To order, use the form at right:

- Select the manufacturer
- Indicate the quantity of boxes you need
- Fill in your name, address and credit card number

For even faster service, call our toll-free number for your area.

In the continental U.S.
1-(800)-FLOPPYS or 1-(800)-521-5700
In Canada • 1-800-265-4824.
In Alaska/Hawaii • 1-800-821-9029.

ALL MAJOR CREDIT CARDS ACCEPTED
Shipping & handling F.O.B. Southfield
Transaction Storage Systems Inc., Southfield, MI



EXPECT A MIRACLE

Circle 393 on Inquiry card.

Size	IBM Qty	Verbatim® Qty	Control Data Ⓞ Qty	maxell Qty
5-1/4" SS	24.90	23.90	19.90	28.90
5-1/4" DS	39.90	34.90	29.90	41.90
8" SS	24.90	—	19.90	—
8" DS	39.90	—	29.90	—
Sub Totals	\$ _____	\$ _____	\$ _____	\$ _____

Name _____ Title _____
 Company _____
 Address _____
 City _____ State _____ Zip _____
 AMEX MASTERCARD VISA
 Card Number _____ Expiration Date _____
 Shipping and handling 1-6 boxes add \$4.00 per order
 7 or more add \$6.00 per order.
 Clip and mail today to: Transaction Storage Systems, Inc.,
 22255 Greenfield Road, Southfield, MI 48075

going to be available for the machine that interests you.

The most popular languages on microcomputers have been BASIC and Pascal. FORTRAN, COBOL, and PL/I have been more popular on mainframes but are only just becoming available for microcomputers. Other languages such as C, LISP, APL, and FORTH have not yet or have only recently begun enjoying general popularity, having been used for the most part only by small, often specialized, groups.

From these languages, programmers must select the ones that are going to be predictably available for most or all existing machines and possible future machines. BASIC and Pascal, with their widespread popularity, can be expected to be available for some time. FORTRAN, COBOL, and PL/I are more complex languages that take longer to adapt to a microcomputer. Only recently have complete implementations of these languages existed for microcomputers, and some microcom-

puters are still not supported. LISP and APL are interesting languages that few people understand as yet. Both are very complex in their implementations and very powerful for programming, but unfortunately there is no reasonably complete implementation of either for any microcomputer. FORTH is a relatively young language that has many dialects. There does not appear to be a single standard implementation that interacts well with host operating systems (because FORTH is often thought of as an operating system in itself). C has gained a lot of popularity recently, and compilers for it have appeared for many microcomputers.

It is important to check for compatibility not only within a language but between machines and compilers. A standard for Pascal exists, but it is generally considered incomplete. Thus each compiler implementer adds additional features in incompatible ways. Because programming in the standard portion of Pascal is very hard, use of nonstandard extensions proliferates and can cause portability problems.

Despite its long life and popularity, there is no recognized standard for BASIC, although one is under development. Different implementations vary wildly from one another. One possible standard is Microsoft BASIC; unfortunately, there is no second source for Microsoft-compatible BASICs, and depending on a sole supplier seems unwise.

The standard for C is contained in Kernighan and Ritchie's book *The C Programming Language* (Prentice-Hall, 1978) and in the Unix C compiler. Both of these standards are complete and reasonably accurate descriptions of the language that compiler writers must adhere to with some care. Unfortunately, the C I/O (input/output) library is not standardized. The resulting problem is surmountable, however: because the I/O library contains nothing but C functions, a different I/O library can be substituted while maintaining portability.

BASIC, Pascal, or C?

The languages that appear to be consistently available on most micro-

Excellence Acknowledged.



Some people demand the best.

Superior quality of superior value identifies the "best" products, and the best in Apple II™-compatible drives is the Micro-Sci line of 5 1/4" floppy disk drives and subsystems.

Business people needing storage, reliability and fast access have been impressed with Micro-Sci's A40 system since we introduced it back in 1979. For a lower list price than the Apple Disk II™s, the A40 offers 20Kb more capacity, faster access time and greater data reliability.

The Micro-Sci A70 drive combines quick access and high reliability with a full 286Kb storage capability.

The newest member of Micro-Sci's Apple II-compatible family, the A2, is a direct replacement for the Disk II,

featuring total compatibility at a lower cost. Better still, you can mix our A2 drive and controller with their drive and controller for complete freedom of interchangeability.

And Micro-Sci's controller includes operating features like jumper-selectable 3.2 and 3.3 DOS.

Give yourself the privilege.

Micro-Sci delivers the most in quality, reliability and performance. So when you consider additional drives or a disk subsystem for your Apple II, indulge yourself in the Micro-Sci alternative.

See our complete product line today at a dealer near you.

(SPECIAL NOTE TO APPLE III™ USERS: Micro-Sci also offers a full range of Apple III-compatible drives. Ask your local dealer for details.)

μ-SCI
MICRO-SCI

Micro-Sci is a Division of Standun Controls, Inc.
2158 SOUTH HATHAWAY STREET • SANTA ANA, CALIFORNIA 92705 • 714/662-2801 • TELEX: 910-346-6739
International Dealer Inquiries... IMC International Markets Corp. Telephone: 714/730-0963 • Telex: 277782-ROBY UR

* Apple, Apple II, Apple III and Disk II are registered trademarks of Apple Computer, Inc.

THINK ELECTRONIC TYPEWRITERS MAKE TYPING EASY? WAIT TILL YOU GET YOUR HANDS ON THIS.



LANIER'S TYPEMASTER™ IS A MASTER OF EASY TYPING.

You get better work back faster and with less effort than electronic typewriters. No more white-outs or retyping.

TypeMaster lets you make corrections, even move whole paragraphs to get letter-perfect pages the first time. And your pages are stored on removable diskettes, so memory is unlimited.

A VISIBLE DIFFERENCE.

Watch this. TypeMaster's full display screen lets you see your page, not just a line or two.

That's why our typing is so easy compared to typing on most electronic typewriters.

TYPEMASTER'S "HANDS ON" TRIAL OFFER.

Even the trial is easy. You'll see how the

TypeMaster not only makes typing easier. But how it also makes deciding between a TypeMaster and any other electronic typewriter a lot easier, too.

Simply send us this coupon to set up an immediate trial or call (800) 241-1706. Except in Alaska and Hawaii. In Georgia, call collect (404) 321-1244. ©1983 Lanier Business Products, Inc.



Mail to: July '83 Byte 476 B G3
Lanier Business Products, Inc.
1700 Chantilly Drive N.E., Atlanta, GA 30324

Name Title

Phone Best time to call

Firm

Address County

City State Zip

LANIER®

WAREHOUSE SOFTWARE

CALL TOLL FREE **1-800-421-3135**
MOST DISK FORMATS AVAILABLE—
 CP/M Program names prefaced with # are also available for IBM PC.

DATA BASE MANAGEMENT SYSTEMS

BUY OF THE YEAR!

DBASEII+EVERYMAN'S DATA BASE PRIMER+EXTRA DISKETTE WITH DBASE ACCOUNTING, MAIL LIST AND INVENTORY PROGRAMS. IBM PC AND CP/M—CALL FOR OUR SPECIAL PRICE.

#Condor III	\$445
#NWA Statpack	\$339
#TIM	\$285
#Infostar	Call
WORD-PROCESSING PACKAGES	
#Wordstar, Mail Merge, Spellstar	\$445
#Wordstar	\$265
#Mail Merge	\$135
#Wordstar, Mail Merge	\$345
#Spell Star	\$145
#Lexisoft Spellbinder	\$270
#Aspen Spellchecker	\$36
#Metasoft Benchmark	\$335
#Sorcim Spellguard	\$135
Peachtree Magic Wand, Spell Check, Mail List	\$325

SPREADSHEETS	
#Calcstar	\$95
#Supercalc	\$185
#Microsoft Multiplan	\$185

ACCOUNTING	
#TCS*Equivalent Of Peachtree* Specially Augmented By Warehouse Software Customized For Your IBM*Terminal And Printer-GL, AR, PA, AP	Each Module \$75
	For All Four. \$275
#TCS Total Accounting	Call
#CYMA	Call
#Peachtree GL, AR, AP	\$375
Sail CP/M For North Star	\$150

LANGUAGES	
C-Basic	\$99
CB-80	\$395
Microsoft Basic 80	\$250
Microsoft Basic Compiler	\$315

TRANSFER PROGRAMS	
Move-It	\$95
IBM PC Move-It	\$110
FOR THE IBM PC	
Best Price In U.S.	
Seven Function Board—Includes Async Adapter, Parallel Adapter, Clock with Battery Back-Up and Software, Game Port, 64K Memory Expandable to 512K.	
1 year warranty	\$2??

Floppy Disk Controller w/Par. or Serial Port	\$235
Plantronics Color + Board	\$365
Tandon 100-2 Drives	Call
256K Ram Board W/Async Port	\$365
Corona Computer—look alike for IBM PC. 128K User Ram—Par. Port—Ser. Port—Two 320K Drives—Mono Display—CP/M-86-MS Dos + other software	
	\$2475
Hayes Smartcom Program	\$49

PC DOS	
IBM PC Volkswriter	\$135
PCI Copy Program	\$34
Datamost Write-On	\$94
Real Estate Investment Prog.	\$94
Microsoft Flight Simulator	\$38
Howard Real Estate Analyzer II	\$185

IBM PC CP/M-86	
CBasic86	\$145
CIS Cobol86	\$595
Pascal MT+86 W/Spp	\$450

TERMS: Prices include 3% cash discount. Add 3% for charge orders. Shipping on most items \$5.00. AZ orders + 5% sales tax.

WAREHOUSE SOFTWARE
 4935 West Glendale Ave., Suite 12
 Glendale AZ. 85301
 (602) 842-1133 Technical Information
 1-800-421-3135 Toll Free Order Line

computers are BASIC, Pascal, and C. Other languages may be added to this list, but none of them is solidly available now. PL/I and FORTH, however, seem to be the most likely candidates for future support.

The speed and size of a compiled program are closely related. In almost all current compilers, smaller source code translates to fewer instructions and so takes less time to execute. Occasional exceptions to this rule exist, but for the most part small programs are fast. When you're writing programs for resale, size and speed are perhaps the most important qualifications of a compiler. For personal use a certain amount of waiting may be tolerable, but speed is often an important factor in program sales. The size of the code affects not only the size of the program as perceived by the user but the number of capabilities that can fit into the program.

Interpreted versions of any given language are slower than compiled code. Because of the importance of speed in influencing user impressions of a program, in the following summary we will consider only the compiled versions of each. A quick look at available compilers for each language shows that BASIC is noticeably slower than the others and that C usually is slightly faster than Pascal. C's performance is due to the fact that it was designed to be very easy to compile. The basic operators in C correspond to basic machine operations on many machines. Thus C can be compiled more closely to a specific machine than Pascal or BASIC, given the same amount of complexity in each compiler.

As mentioned, separate compilation is an important feature in the development environment. Neither BASIC nor Pascal offers separate compilation as a standard feature, although some implementations offer this capability. Note, however, that using separate compilation features that vary from one system to another causes portability problems. Separate compilation, a standard feature of C, is available in all implementations.

It's difficult to judge portability accurately. At present, no accepted standard for BASIC exists, and the

standard for Pascal is considered very limiting and is almost always extended. The standardization process for Pascal is farther along than that for BASIC, but in neither case do the available compilers adhere closely to the standards. C has a well-defined standard, the version 7 Unix C compiler, which is also well documented in Kernighan and Ritchie's book. Almost all existing compilers adhere to the standard or provide a proper subset of it with no loss of language generality. Thus the portability of C programs is much higher than those written in BASIC or Pascal.

BASIC is the weakest language for structured programming. Most BASIC systems do not have named subroutines, local variables, do-until-endo, while-do- endwhile, or record structures, to name a few limitations. Some of these features are being added to recent BASIC systems, but extensions are not being done consistently from one system to another. Pascal is much better because it provides almost all of the common structured-programming constructs. C also provides a full set of structured-programming features, and it has greater flexibility as well.

BASIC does not provide any facilities to support the use of data abstractions. It has a fixed set of data types and no facilities to define more. Pascal provides structures and pointers, both of which can be used to implement data abstractions but present limitations.

In Pascal, to define a data object and several procedures that act on it so that they can be used anywhere in the program, you must define all data and functions at the top level of the program. This means, first, that the structure of the source is forced on the programmer. Second, it means that the entire representation of the data is accessible to the entire program, making name conflicts and invalid data access very likely. Finally, the lack of separate compilation means that all of the code associated with a data abstraction must be inserted into the source for a particular program that uses it.

C is better suited to data abstractions. A data abstraction can be a

COMPUTER WAREHOUSE

CALL TOLL FREE **1-800-528-1054**

SPECIAL OF THE MONTH

**UNBELIEVABLE SYSTEM!
UNBELIEVABLE PRICE!
\$1399**

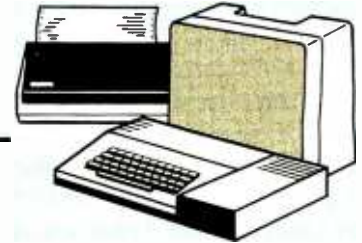

**PIED PIPER • GEMINI 10X
TAXAN 12" AMBER MONITOR
5 SOFTWARE PACKAGES**

System includes: Pied Piper Portable (features below) • Gemini 10X
• Taxan KG-12N • CPM • Perfect Writer • Perfect Speller • Perfect Calc
• Perfect Filer • All necessary cabling.

PRINTERS

C-Itch	
F-10-Parallel or Serial	\$1049
55 CPS Serial or Parallel	\$1555
8510 Parallel (Prowriter)	\$339
Computer International	
Daisywriter 2000 w/16K	Call
Daisywriter 2000 w/48K	Call
Comrex	
CR-1-S	\$665
CR-1-P	\$755
CR-2	Call
Datasouth	
DS180	\$1155
Diablo	
620 RO	\$910
630 RO	\$1710
IDS	
Microprism 480	\$480
Juki	
6100	Call
Epson	
All models	Call
NEC	
PC-8023A	\$399
3510	\$1365
3550	\$1710
7710	\$1900
2010	\$785
2015	\$785
2050	\$910
Okidata	
82A	\$385
83A	\$630
84P	\$975
84S	\$1060
92	\$490
93	\$835
Olivetti	
PRACTIS 41 (w/interface)	\$725
2300 INK JET	Call
Silver Reed	
EXP550P	\$675
EXP550S	\$690
Star Micronics	
Gemini-10X	Call
Gemini-15X	Call
Tally	
1805/1802	\$1455
MT 160L w/Tractors	Call
MT 180L w/Tractors	Call
Texas Instruments	
810 Basic	\$1245
850	\$650
Toshiba	
P1350	\$1460
Transtar	Call

MODEMS

Hayes	
Smartmodem	\$205
Smartmodem 1200	\$499
Novation	
CAT	\$140
D-CAT	\$155
J-CAT	\$110

DISK DRIVES

Rana (Drives for Apple)	
Elite 1	\$245
Elite 2	\$380
Elite 3	\$490
Controller (w/Drive only)	\$75
1000 (For Atari)	Call

VIDEO TERMINALS

ADDS	
A-1	\$445
VIEWPOINT 60	\$685
Hazeltine	
Esprit I	\$485
Esprit II	\$445
Esprit III	\$525
Qume	
QVT 102 Green	\$550
QVT 102 Amber	\$560
Televideo	
910 or 910 Plus	\$560
925	\$730
950	\$905
970	\$1015
Wyse	
Wyse 100	\$680
Wyse 300	\$1020
Visual	
Visual 50	\$610
Zenith	
Z-29	\$635
ZT-1 Keyboard Only	\$350

MONITORS

Zenith	
12" Green Screen	\$95
12" Amber Screen	\$120
Amdek	
Video 300	\$130
Video 300A	\$145
Color I	\$270
Color I Plus	\$310
Color II	\$450
Color III	\$360
NEC	
JB 1201	\$155
JB 1260	\$115
Taxan	
12" Amber	\$125
USI	
12" Amber	\$150

DISKETTES

Maxell	
MD-1 (Qty. 100)	\$250
Scotch	
744-0 (Qty. 100)	\$225
Elephant	
S/S/S/D (Qty. 100)	\$180

COMPUTERS

Altos	
Series 5-15D	\$2100
5-80-10 W/MPM	\$4200
Atari	
600XL	\$149
800XL	\$219
Corona	Call
NEC	
APC HO1	\$1875
APC HO2	\$2375
APC HO3	\$2875
Northstar	
Advantage	\$2160
Advantage w/5MB	\$3345
Advantage W/15MB	\$4315
Horizon II 64K QD	\$2625

Pied Piper

Communicator I Portable, Z-80, 64K Ram, Full sized keyboard, Slimline 5 1/4 Disk Drive with 1M Byte of storage, RF Modulator for use with T.V., Monitor output, Perfect Word, Perfect Calc, Perfect Speller, Perfect Filer, CPM, 90-day nationwide warranty **\$995**

Sanyo 2-Drive System

\$1850

System includes: wordstar, clacstar, mailmerge, spellstar, infostar, Sanyo basic, CPM. \$1450 with 1-Drive

Televideo Systems

TS-802	\$2525
TS-802H	\$4450
TS-803	Call



2222 E. Indian School Rd.
Phoenix, Arizona 85016

Order Line: 1-800-528-1054 Other Information: 602-954-6109
Order Line Hours: Mon.-Fri. 10-5 MST Saturday 9-1 MST

Prices reflect 3% to 5% cash discount. Product shipped in factory cartons with manufacturer's warranty. Please add \$8.00 per order for shipping. Prices & availability subject to change without notice. Send cashier's check or money order...all other checks will delay shipping two weeks. 9/83

single compilation unit in which only the desired function names are visible to the rest of the program. The data representation can be completely hidden within the single source file. Various modules can be maintained separately and linked together to form the final program. C does not provide type checking on these user-defined types—a limitation that is alternately a blessing and a curse. You can use a programming tool such as lint (so named because it "picks nits" in your programs) on Unix for type checking.

Another advantage of C over Pascal is its flexibility in terms of how you can program. There are always several different ways to code a given construct, and you can choose an appropriate one depending on the level of readability, speed, or programming style you want. You are not forced into a programming style by the language; you are free to explore the style suggested by the task at hand. This ability is most apparent when a particular section of the code

must run very fast. C provides constructs such as pointers and register variables that can be used to locally improve the speed of a particular spot of code instead of depending on the overall quality of the compiler.

Picking a Compiler

Having picked a language, C in this case, we still have to pick a compiler. Several C compilers are available for each microprocessor, so we can pick the one that comes closest to meeting other design goals.

The first thing to check on a compiler is the accuracy and completeness of its implementation of standard C. It is not actually necessary that it implement the full language. The C programs should run on a large variety of compilers, so it is best to stay away from features that might be missing on some compilers. C has very few such features; most have to do with features added in Unix since the C book was written. Still, the compiler must implement most of the language accurately.

It is also important to check how long it takes the compiler to compile a large program. Because the compiler will run many times, long compilation times can be a problem. The difference in compiling time among the available compilers is incredible. I have observed compiling times for compilers working on the same medium-sized program vary from 40 seconds to 15 minutes.

The size and speed of the resulting code will affect every program you write for it every time it is run. People might be willing to wait around for the compiler, but it is hard to get them to buy a slow program. The size of the compiled code usually varies by a factor of up to 2 between compilers. Remember, a code-size improvement of just 1 percent in a medium-to-large program can make room for another feature. Fine differences are worth watching. ■

Jason Linhart is president of Mark of the Unicorn Inc. (222 Third St., Cambridge, MA 02142).

C LANGUAGE TRAINING FROM PLUM HALL

- **C Programming Workshop:** Comprehensive, hands-on C course for programmers.
- **Advanced C Topics Seminar:** Includes Efficiency and Portability; for lead programmers.
- **UNIX Workshop:** Hands-on course in uses of UNIX; for general audience.
- Each is a 5-day course: available in-house or at public sessions.

Learning to
Program in
C

Thomas Plum

372 pp, 7½"x10", Price \$25.

● AND AN INTRODUCTORY BOOK ON C LANGUAGE:

Learning to Program in C, by Thomas Plum, teaches C language from the ground up. With or without previous programming experience, anyone acquainted with computers will find a clear description of how C works.

You will find guidelines for writing portable programs that will run on a wide variety of modern computers—micro, mini, and mainframe, with excellent efficiency in all these environments.

PLUM HALL 1 Spruce Ave, Cardiff, NJ 08232
Phone orders: 609-927-3770

Send information on Plum Hall Seminars on C and UNIX™

Check
 Mastercard Visa
 American Express

Exp. Date _____

Please send me _____ copies of "Learning to Program in C" (NJ residents add 6%; overseas add \$5 airmail.)

NAME _____

COMPANY _____

ADDRESS _____

CITY _____ STATE _____ ZIP _____

Card No. _____

Signature _____ B2

Incubation Complete

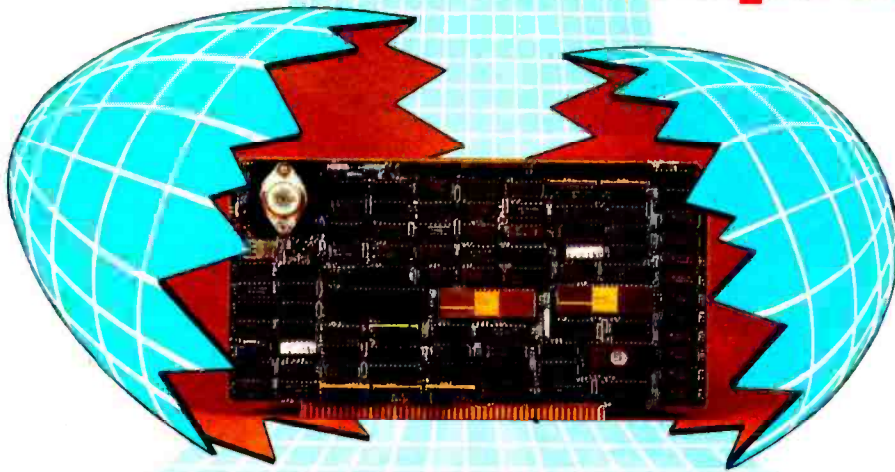

A Third Generation is Born

SBC 300

(Pictured above)

A Z80 based microcomputer board with memory and I/O functions

- Fully complies with IEEE 696 Standard
- 4/6/8 MHz Z80 A/B/H*
- Supports CP/M® Plus
- Operates as bus master/slave for multi-user, multi-processor architecture.
- 64K on board memory, dual ported, parity checked
- 2 serial ports, 1 full SASI port
- All I/O drivers on board
- Memory management
- Full 24 bit address capability
- 3-16 bit CTC's



ExpandoRAM IV—Random access memory board utilizing 64K or 256K NMOS RAM chips

- Fully complies with IEEE 696 Standard
- 256K capacity with 64K chips
- 1024K capacity with 256K chips
- Error checking and correction (2 bit detection, 1 bit correction)
- On board refresh
- Supports both 8 and 16 bit data transfers
- 24 bit addressing



SD300—A new series of compact yet expandable S-100 microcomputers.

- Compact size approximately 4" x 14" x 17"
- 6 Slot motherboard
- Rugged metal enclosure
- Supports up to 5 users

OEM Version: Designed for ease of integration and maximum flexibility

- Z80 CPU
- 256K RAM
- Versafloppy II with free CP/M Plus™

Discless Version: An Ideal high performance system for disk intensive applications. Eliminates disk wait states for spread sheets, spelling checkers, and network operation. Utilizes SDSystems RAMDisc and ROMDisc modules.

VFW-3: A single board controller for floppy and Winchester disk drives:

• Fully complies with IEEE 696 Standard • Free copy of CP/M Plus™ included • Up to 4 Floppies and three Winchester drives may be controlled by VFW-3 • Data transfers to and from board under DMA or programmed I/O control • Supports 24 bit address space.

CP/M Plus™, high performance single user operating system.

• CP/M® 2.2 compatible—no modification! • When used with SDSystems 256K memory board speeds are up to 7 times faster than CP/M® 2.2. • High performance file system • MP/M® II file password protection • Time and date stamps on files • Support for 1 to 16 banks of RAM • Support for 1 to 16 drives of up to 512 MB each • Easy to use system utilities with HELP facility • Powerful batch facility • Sophisticated programmer utilities.

RAMDisc 256: A solid state disk emulator that greatly increases system performance by eliminating disk waits in disk intensive applications. Excellent for spreadsheets, spelling checkers and software development.

• 256K capacity • 1 mb total bus capacity • CP/M® 2.2, PLUS™ compatible • I/O port addresses user selectable • Storage locations addressed by on board 20 bit counter • On board refresh.

ROMDisc 128: An EPROM board that replaces a floppy disk drive for the purposes of booting CP/M® and loading application programs.

• Provides non volatile, permanent storage of programs and data • Utilizes 2732 or 2764 EPROMS, (16 max) • 128K capacity per board • 512K system capacity • Use with SDSystems RAMDisc to configure a stand alone or network discless system • CP/M Plus™ available in eproms • Serial port provided.

CP/M® 2.2 and CP/M Plus™ are registered trademarks of Digital Research, Inc. *Z80 product of Zilog Corp.

SDSYSTEMS

A Syntech Company

10111 Miller Road • Dallas, Texas • (214) 340-0303 • TLX-682 9016

Circle 351 on Inquiry card.
www.americanradiohistory.com

IBM UNLEASHED



Now you can move your IBM PC¹ from the fast lane into the jet stream. With the Personal Hard Disk™ from Corona.

More power to you.

The Corona Personal Hard Disk really revs up your IBM PC, with none of the floppy bottlenecks, headaches and hassles.

You get 5 to 10 megabytes of storage.

Speeds up to ten times faster than floppy disc drives.

The high reliability of a hard disk.

In an easy add-on external package, or a convenient internal plug-in.

Lightning strikes twice.

If that's not enough, you also get a lot of the features of the Corona PC, our own 16-bit desktop and portable personal computer.

Like free RAM "disk." Just define blocks

of main memory as a disk and load your programs, then run them at incredible microsecond speeds.

Like disk partitioning that supports several operating systems at the same time, so MS-DOS², CP/M-86³ and Pascal are all right there when you need them.

Like simple menu operation that makes your PC friendlier than you would have believed possible. Small directories. Automatic backup. And much more.



All backed by Corona's exclusive DataGuard™ and FailSafe™ data protection systems for maximum reliability.

So if you're hungry for power and your IBM

just can't keep you fulfilled, get your hands on the Personal Hard Disk from Corona.

It'll set you free.

The Personal Hard Disk is available in internal and external, 5 and 10 megabyte versions. For the name of your nearest Corona dealer, just call us toll-free at 800-621-6746. Or write Corona Data Systems, 31324 Via Colinas, Westlake Village, CA 91361. (213) 991-1144.



FEEL THE POWER.

Circle 114 on Inquiry card.

© Corona Data Systems. 1983. 1. IBM Corp.
2. Microsoft. 3. Digital Research.

The Unix Tutorial

Part 1: An Introduction to Features and Facilities

A look at some of the programming tools available to a Unix user

by David Fiedler

C. *Unix*. In the acronym-happy world of computers, these collections of letters stand out. The C language, it is whispered, can replace everything from assembly language to Pascal, and is only understandable by those willing to deal with a 5-year-old text and lots of squiggly characters; Unix, the legendary operating system from Bell Laboratories, is now being offered to the public under a half-dozen names and by four dozen computer manufacturers. Why are C and Unix always spoken of in the same breath, and why are so many people talking about them at all?

This three-part series will attempt to answer this and other questions about Unix and C. This month I'll present a tutorial overview of the Unix operating system and its toolbox of utilities, with explanations of its internal structure as well as its user interface.

In part 2 I'll discuss a few more Unix utilities and the variety of applications that have been written in or adapted to the Unix environment.

Part 3 will focus on Unix implementation by different software vendors for several computers and how Unix compares to its competitors—Unix work-alikes, look-alikes, and the other 16- and 32-bit operating systems.

Unix was specifically designed to make software development easier.

The popularity of Unix is easily explained. It was the first complete programming environment designed by programmers to make it easier to write programs. (See the text box "The History of Unix.") Like the C language, it has both elegance and simplicity, and like most great discoveries, its virtues seem so obvious that you may wonder why no one thought of them before. (See figure 1 for a schematic breakdown of Unix's features.)

The File System

On some operating systems, you

must specify what kind of disk file you intend to work with before you can gain access to it, and then you can use the file only in predefined ways. The actual storage of the file may be different for a sequential file, a random-access file, and a database file. When writing a program to read a file, you may have to include tests for the physical end of the file, the logical end of the file, the end-of-file marker, reading past the last record, or all of the above. On Unix, all files are alike. Each file is simply a sequence of bytes, whether it contains text, program source code, executable object code, or the disk directory. If you wish to read one byte, you can. If you wish to read the 768th byte from the end of the file, you can do that too, provided the file has at least 768 bytes. You need follow no predefined structure of files to work with them. Naturally, some of the system programs expect a certain structure in their data files, but such constraints are not forced by the system itself.

The way you deal with files at the user level is particularly interesting. On many large timesharing computer systems and most home or

Unix is a trademark of Bell Laboratories.

THIS IS IT!

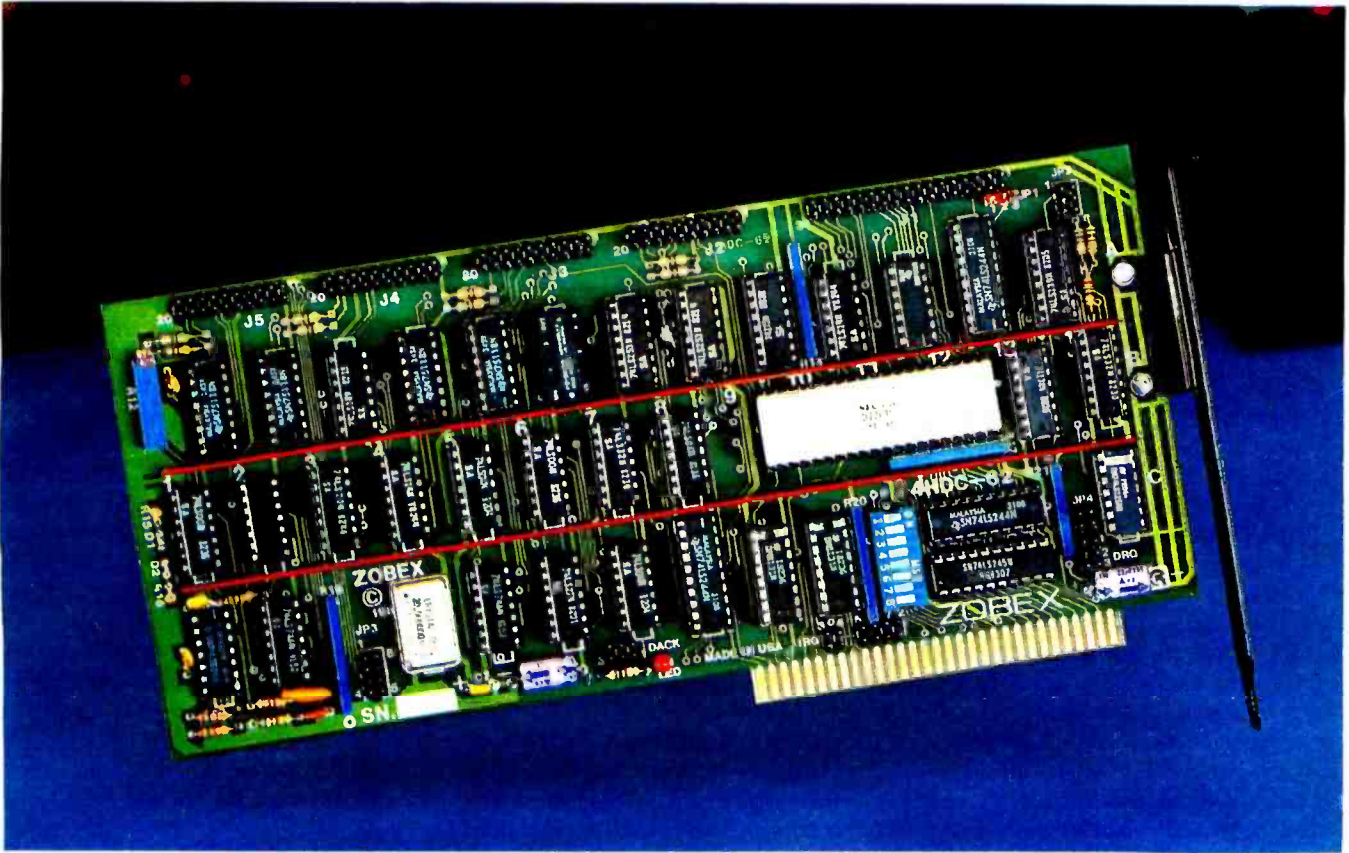

The **HARD DISK CONTROLLER** for IBM PC and TI PROFESSIONAL Computers

Whether you use MINISCRIBE, SEAGATE, SHUGART, TANDON, DISKTRON, SYQUEST, MAXTOR or others with ST506 compatible interface, this is the ONLY BOARD you need.

It plugs right into the IBM PC, and features:

- Parallel seek — allows overlap seeks between drives
- ECC generation/check/correction
- CRC generation/check
- Up to 4 disk drives
- Write-protect each drive individually
- CARTRIDGE CHANGED, CHANGE CARTRIDGE and CARTIDGE IN lines are provided to allow use of cartridge type disk drives
- Compatible with 140 Mbyte MAXTOR drive
- Programmable track format: data length is variable from 128 - 4095 bytes/sector
- Data transfer rate 5 Mbits/sec
- Multiple sector transfer
- Multiple track transfer
- Data scan, Data verify commands
- DMA Data transferring

Dealer's inquiries invited.

Competitive Pricing

HARD DISK SUBSYSTEM AVAILABLE

For more information contact:

ZOBEX

7343-J Ronson Road • San Diego, CA 92111 • (619) 571-6971

ZOBEX IS A TRADEMARK OF ZOBEX CORPORATION

IBM IS A TRADEMARK OF INTERNATIONAL BUSINESS MACHINES CORPORATION

TI PROFESSIONAL IS A TRADEMARK OF TEXAS INSTRUMENTS CORPORATION

Circle 433 on inquiry card.

www.americanradiohistory.com

The History of Unix

In the late 1960s, a project was underway at the Massachusetts Institute of Technology (MIT) to improve the state-of-the-art in timesharing software. Along with MIT, Bell Laboratories and General Electric (GE was once a mainframe computer manufacturer) were collaborators in the venture. But Multics, as the system was christened, was too big and slow—an overdesigned behemoth of the software world. So Bell Labs pulled their people out of the project, which left MIT and GE to develop the system further on their own. (They did, and Honeywell, who later bought GE's computer operation, still sells Multics.) Unfortunately, that left Ken Thompson, a computer scientist at Bell Labs, without any hardware to run his video game.

Thompson had written a simulation of the solar system, called *Space Travel*, which ran on the Multics system on a timesharing terminal. The loss of Multics was the impetus he needed to find hardware he could use exclusively. He gained access to a Digital Equipment Corporation (DEC) PDP-7, complete with a video display that would enhance *Space Travel* tremendously. While Thompson was rewriting *Space Travel* for the PDP-7, he began experimenting with some ideas he had for a new type of file system. Working in PDP-7 assembly language, he soon had his file system running with some utility programs and a central core (or kernel) that together made a rudimentary operating system. Here was a system designed by one man for the sole purpose of making his own software-development work easier. Unix was thought to be a good name for it—the Uni (one) was a word play on the Multi (many) of Multics.

Unix came to the attention of others at Bell Labs, including Dennis Ritchie, another systems software designer. Together, Ritchie and Thompson enhanced Unix, adding some word-processing facilities in response to hints that another department needed a word-processor. This earned the designers enough funding for a PDP-11 minicomputer, a more modern and reliable machine than the PDP-7. Eventually, other departments bought PDP-11s and chose to use Unix for the software base rather than DEC's own operating systems.

But Thompson, dissatisfied as he was with other operating systems, also felt that programming languages could be improved. FORTRAN was tried and discarded. He then worked for a while on BCPL (Basic Combined Programming Language), which was a simplification of CPL, itself a simplification of the Algol 60 language (today, we would call Algol 60 a Pascal-like language). Thompson condensed BCPL down to its most basic features. The interpreted language that resulted he named simply B. Ritchie then took the best parts of B, reworked them until he had a language that was simple and elegant, added data structures, and called it C. Ritchie and Thompson both felt this was a language suitable for systems programming—one that allowed a programmer to express concepts clearly without being tied to one machine's architecture, and yet was efficient enough so that assembly language would not be needed for speed.

Getting a Handle on Portability

Unix was rewritten in C in 1973, whereupon Ritchie and Thompson realized that because C was a relatively high-level language, compilers could be written on other computers to give them C capability too. And because Unix was written in C, theoretically Unix could then be moved to these other machines. The experiment was tried in 1977 with an Interdata 8/32, a 32-bit minicomputer that was as unlike the PDP-11 as possible. All code specific to the PDP-11 was taken out of the kernel and rewritten to make it easy to transport Unix. After the Interdata test, they moved Unix to an IBM/370 mainframe. With each trial they learned more about C, Unix, and portability in general.

Until Unix, operating systems were written exclusively in assembly language. This long, error-prone process seemed the only one appropriate to an industry that considered machine efficiency to be more essential than human efficiency because computers were more expensive in dollars and cents than human labor. Compared to other languages, assembly language allows the fastest execution of instructions and takes up the least memory space; therefore, programs as important as operating systems could only be written in assembly language. Who cared if a programmer or

two went crazy trying to understand it? What was the difference if it took a long time to write and three times as long to debug?

Ritchie and Thompson saw that a software designer's environment was more important, in the long run, than that of the computer; computer hardware tends to get cheaper and faster, while the cost of labor in both economical and emotional terms tends to go up. This last is especially true when the software tools at hand are not appropriate for the job. Unix forever broke the notion that a system had to be written in assembly language and therefore tied to a specific computer design, word size, or architecture. For the first time, an entire programming environment, including file system, kernel, applications packages, utility programs, and user interface, could be moved to an entirely different type of machine.

Think about that for a moment. Look at the CP/M 2.2 operating system. CP/M has gained immense popularity; it runs on computers made by literally hundreds of different manufacturers and supports many different languages and applications packages. Why is it so popular with computer makers? CP/M is portable to many different hardware configurations. The catch is that the systems must use a microprocessor than runs 8080 assembly code.

In comparison, you can now run Unix or Unix-compatible systems on computers based on any of these processors: 8080, Z80, 8086, 8088, Z8000, 68000, 16032, LSI-11, PDP-11, VAX, HP-9000, Perkin-Elmer, Gould S.E.L., BBN C-Machine, IBM Series/1, and IBM/370. Typical hardware configurations range from \$5000 to considerably more. A program correctly written in C for any of these machines will run on any other one, needing only to be physically moved and recompiled. No doubt you can see why so many software houses have suddenly discovered Unix. By using C and Unix, they can expand their potential customer base tremendously with little trouble—one user manual, one customer support group, one version of source code. The net result can benefit everyone with better, more widely used software at lower prices.

COMPUTERSCOPE

USER PROGRAMABLE MULTIFUNCTION INSTRUMENT

by RC ELECTRONICS INC.

DIGITAL STORAGE OSCILLOSCOPE

SIGNAL AVERAGER

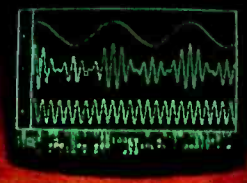
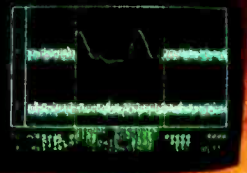

SPECTRUM ANALYZER

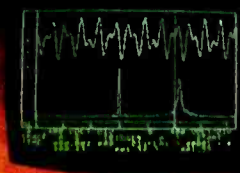

HISTOGRAM ANALYSIS PACKAGE



MULTIPLE TRACE DISPLAY

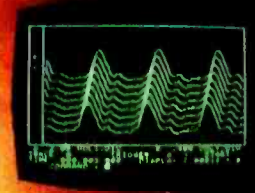

APPLE II COMPATIBLE

PROGRAMMABLE FUNCTION GENERATOR

STRIP CHART RECORD

DISK STORAGE



THE FIRST MULTIFUNCTION INSTRUMENT BASED ON A PERSONAL COMPUTER

Why pay for several different companies to design microprocessors into their instruments when we have upgraded a general-purpose microcomputer to accomplish the same tasks. R.C. Electronics has developed special hardware to give the **COMPUTERSCOPE** performance matching that of dedicated instruments with all the flexibility of a general-purpose computer. The **COMPUTERSCOPE** is hardware- and software-compatible with the Apple II, but with bonus features like a heavy-duty power supply and a 10-key pad for data entry.

For further information on the **COMPUTERSCOPE's** capabilities, contact R.C. Electronics for the name of your local representative.

5386 HOLLISTER AVE. • SANTA BARBARA, CA 93111 • (805) 964-6708
Telex 295281

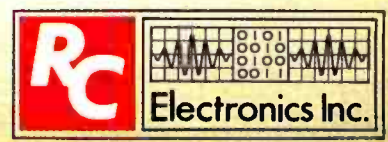

Champagne performance.

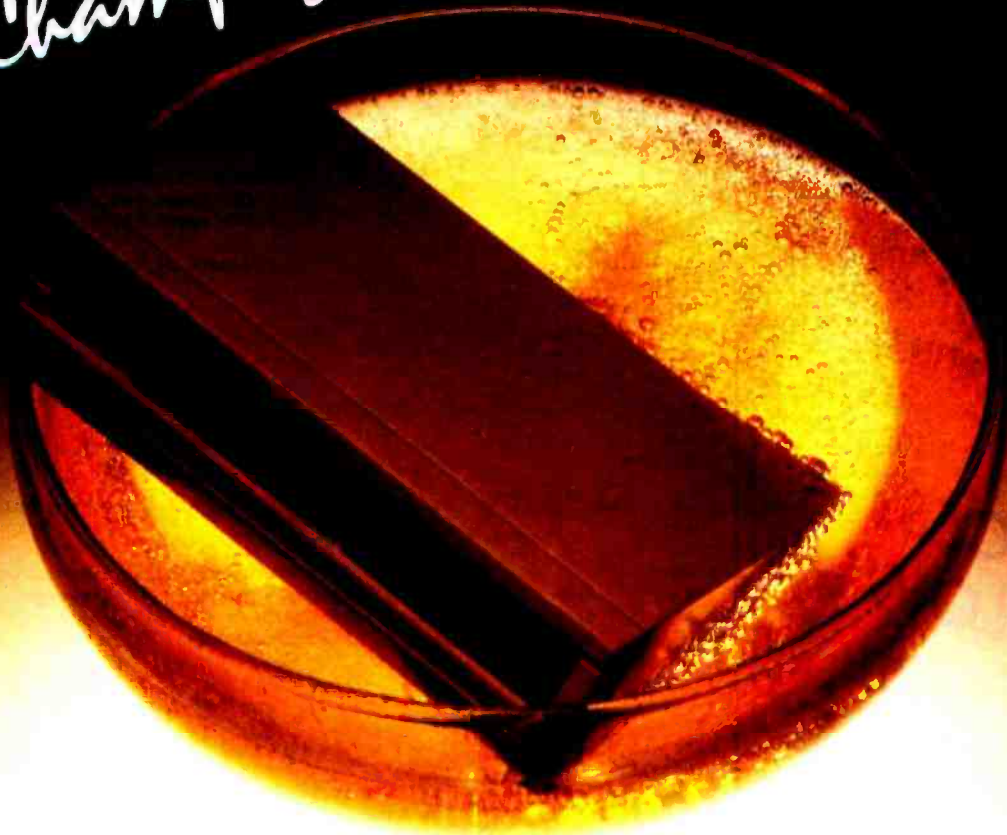

For businesses on a beer budget.

For a small business system that's beer-budget priced, there's no better buy today than the MIC 500 from Multitech.

It's got the same sparkling performance features as other popular micros: Z80A processor, 64K RAM, CP/M 3.0 operating system, and a full complement of business software, including Perfect Writer, Perfect Speller, Perfect Calc and Perfect Filer.

Beyond that, the MIC 500 is definitely not ordinaire. With its 400K bytes of low-profile disk storage, it's in a class by itself. And unlike comparably priced micros, the MIC 500 is easy to expand via two RS-232C ports and a parallel printer port. Or to program with languages like CBASIC, COBOL and Pascal.

The corker, though, is price: \$1,395 without terminal, or \$1,995 with. Of course, OEMs and dealers can expect discounts when you buy them by the case. For full details, write Multitech Electronics, 195 W. El Camino Real, Sunnyvale, CA 94086. Or phone (800) 538-1542; in California, (408) 773-8400.



**MULTITECH
ELECTRONICS**



ANADEX

Epson

DATASOUTH

NEC

Daisywriter

Diablo

Ribbons

Gemini

MANNESMANN TALLY

Okidata

MPI

PRICES SO LOW—

WE CAN'T LIST THEM!

ADDS

Smith Corona

QANTEX

LEAR SIEGLER

SUPPLIES

AMPEX

ESPRIT

All equipment is in factory cartons with manufacturers' warranty. Prices subject to change without notice. Most items in stock or shipped as received.

1 **NATIONWIDE SERVICE, MOST PRODUCTS**
SUPER WAREHOUSE

P.O. BOX 373 WALLINGFORD, CONNECTICUT 06492
ORDER LINE ORDER HOURS
203-265-1223 9:00 AM - 5:00 PM-EST
MONDAY-FRIDAY

PHONE ORDERS FREE
(ONE DOLLAR CREDIT FOR PHONE ORDERS)

Listing 1: A sample session on a Unix System with comments added. The \$ is the Unix prompt.

```
login: dave                                     (typing error)
Password:
Login incorrect                                 (login name not recognized)
login: dave
Password:
Last login: Wed Mar 30 18:46:57 on serial1

See /usr/news/READ_ME.                         (system message of the day to all users)

$ ls                                             (what files are in my home directory?)
bin      mbox      sieve.c  src      test1.c

$ who                                            (see what users are logged on the system)
dave     serial1  Mar 30 18:46

$ df                                             (see how much space is left on disk)
/usr     (/dev/usr ): 12045 blocks  8109 i-nodes
/        (/dev/root ):  8071 blocks  6666 i-nodes

$ time cc sieve.c                               (time the compilation of a benchmark)

real    36.0                                     (actual elapsed time)
user    6.2                                     (time spent executing the cc command)
sys     6.9                                     (time spent in system getting files, etc.)

$ time a.out                                    (execute benchmark and time it too)

1899 primes
real    8.0
user    7.4
sys     0.4

                                     (this is small since the benchmark
                                     program is CPU-intensive: no files to get)

$ pwd                                           (what directory am I currently working in?)
/usr/dave

$ cd ../pwd                                     (go up one branch and tell me where I am)
/usr

$ ls                                             (what files or directories are here?)
adm      demo      ega      include  man      preserve tmp
bill     dict      games    lib       mbsi     spool
bin      dave     garp     lost+found news    src

$ cd;ls                                         (go back to home directory and list files)
a.out    bin      mbox     sieve.c  src      test1.c

$ ls -al                                        (show in long format with hidden files)
total 113
drwxr-xr-x 5 dave      224 Mar 30 18:53 .
drwxr-xr-x 3 root      544 Mar  7 11:05 ..
-rw-r--r-- 1 dave           0 Feb 11 22:20 .news_time
drwx----- 2 dave      240 Nov 13 14:49 .personal
-rw-r--r-- 1 dave      183 Feb 27 03:37 .profile
-rw-r----- 1 dave    42170 Mar  5 23:36 .rogue.save
-rwxr-xr-x 1 dave     8696 Mar 30 18:53 a.out
drwx----- 2 dave      32 Oct  4 17:02 bin
-rw-r----- 1 root     576 Oct 12 21:33 mbox
-rw-r----- 1 dave     904 Oct 21 15:46 sieve.c
drwx----- 2 dave      32 Oct  4 17:02 src
-rw-r----- 1 dave      79 Oct 21 15:46 test1.c

$ cat .profile                                  (look at Shell program executed at login)
                                     (here some Shell variables are set)
PATH=/usr/games                         (set default command search path)
SHELL=/bin/sh                            (tells which Shell I'm using)
ED=/bin/vi                                (and which editor)
export PATH SHELL ED                      (lets these variables be used later)
umask 027                                  (sets default protection)
stty -tabs                                 (and my desired terminal settings)

$ stty                                         (look at current terminal settings)
speed 1200 baud
erase = ^H; kill = @; intr = ^?; quit = ^\
start = ^Q; stop = ^S; eof = ^D; brk <undef>;
even odd -raw -nl echo -lcase -tabs -cbreak

$ mail root                                    (complain to the super-user that my
                                     backspace key doesn't work correctly)
```

Listing 1 continued on page 194

Looking Good!



Composite Color Attractively Priced

- **Fine Resolution**—350 x 350 lines with 400 at center.
- **Full Compatibility with IBM PC**—as well as Apple II, Apple III, and many other popular personal computers.
- **Proven BMC Quality, Performance and Reliability.**

Contact your local dealer or call BMC direct for the dealer nearest you.

IBM® is a registered trademark of International Business Machines; Apple® is a trademark of Apple Computer, Inc.



LOS ANGELES
16830 South Avalon Blvd.
Carson, CA 90746
Telex: 664258 BMC GDNA
Phone: 213-515-6005

NEW YORK
450 Borell Avenue
Carlstadt, NJ 07072
Phone: 201-939-7079/7061

Dealer inquiries circle #51. End users circle #53.

Setting the standard in price and performance.

www.americanradiohistory.com

**!!!!COMPETITIVE PRICES!!!!
FROM DIGITAL DIMENSIONS**

FOR THE IBM P.C.

FULL AST LINE.....	CALL
NEC Spinwriter 3550..33CPS.....	\$1,990
NEC 8023A.....	\$415
Quadram Quadboard w/64K.....	\$320
Quadram Quadboard w/128K.....	\$380
Quadram Quadboard w/192K.....	\$430
Quadram Quadboard w/256K.....	\$490

OKIDATA

ML-80.....	\$317	ML-82A.....	\$395
ML-82A.....	\$639	ML-83A.....	\$639
ML-84S.....	\$1,083		

**ML-92..80 COL.,
160 CPS PARALLEL..... \$509**

**ML-93..136 COL.,
160 CPS PARALLEL..... \$832**

THE GORILLA

**SEIKOSHA DOT MATRIX, PARALLEL
50 CPS PLUS GRAPHICS..... \$241**

**INFO RUNNER RITEMAN
120 CPS, EPSON COMPATIBLE FRICTION
& PIN FEED, PARALLEL..... \$390**

IDS

PRISM 80..3.4K & 200 Sprint.....	\$1,036
Inc. sheet feed, color & graphics...	\$1,429
PRISM 132..3.4K & 200 Sprint.....	\$1,195
Inc. sheet feed, color & graphics...	\$1,591
MICROPRISM 480.....	\$569

DIABLO

Diablo 620.....	\$1,015
Diablo 630.....	\$1,915

C. ITOH

Prowriter..80 Col., 120 CPS, Parallel.....	\$396
Prowriter 2..80 Col., 120 CPS, Parallel.....	\$696
Starwriter F-10..40 CPS.....	\$1,425
Printmaster F-10..55 CPS.....	\$1,595

MODEMS

Hayes 300 Baud Smart Modem.....	\$219
Hayes 1200 Baud Smart Modem.....	\$515
Hayes Integrated Modem for the IBM PC.....	\$499
DATEC 212A-300/1200 bps.....	\$445
212A-300/1200 bps Inc. Auto Calling Unit.....	\$515
RIXON PC-212A Modem Card For the IBM PC.....	CALL

MONITORS

Taxan	
RGB I - Med. res. color.....	\$309
RGB III - High res. for the IBM and Apple III.....	\$509
Green Phosphor.....	\$159
Amber.....	\$169
Amdek	
Color I.....	\$309
Color II.....	\$609

DIGITAL DIMENSIONS

190 Chapel Rd., Manchester, CT 06040

Info & Orders Call 203-649-3611
Orders Only 1-800-243-5222

C.O.D. Welcome. Allow 2-3 Weeks For Checks. MC VISA OK
All Prices Include UPS Ground Freight In U.S.
CT Residents Add 7 1/2% Sales Tax.
Prices Subject To Change Without Notice.

Listing 1 continued:

is there a problem with stty accepting ^H as erase? my stty is set that way but the system doesn't seem to see them.

```
$ ls -l / (look at files under the root directory)
total 823
drwxr-xr-x 2 root          32 Feb 10 14:49 bck
drwxr-xr-x 2 root          2880 Mar 23 22:35 bin
drwxr-xr-x 3 root          3552 Mar 11 20:57 dev
drwxr-xr-x 2 root          320 Feb 12 02:26 etc
drwxr-xr-x 3 root          576 Feb 18 20:18 lib
drwxr-xr-x 2 root          32 Jan  5 23:38 lost+found
-rw-rw-rw- 1 root          3862 Mar 16 08:08 rst011966
drwxr-xr-x 2 root          544 Mar 30 18:55 tmp
drwxr-xr-x 5 root          80 Feb 18 21:02 unify
-rwx----- 1 root          67487 Jan 19 08:26 unix
drwxr-xr-x 23 root         544 Mar  7 11:05 usr
```

```
$ ls -ld /etc (look at protections on /etc directory)
drwxr-xr-x 2 root          320 Feb 12 02:26 /etc
```

```
$ cat /etc/passwd (look at system password file)
root:uWAMrSGHnJIw:0:0:/:/bin/sh
daemon:x:1:1:/:/
sync::1:1:sync command:/tmp:/bin/sync
bin:x:3:3:/:/bin:
uucp:not-nov:4:4:/:usr/spool/uucppublic:/usr/lib/uucp/uucico
dave:RMuFz3n/yNaPo:10:2:Dave Fiedler (InfoPro Systems):/usr/dave:/bin/sh
demo::100:100:guest account:/usr/demo:/bin/sh
```

```
$ fortune (fortune "cookie" selected at random)
As the trials of life continue to take their toll, remember that there
is always a future in Computer Maintenance.
```

```
login: (typed control-d and ended input to Shell)
```

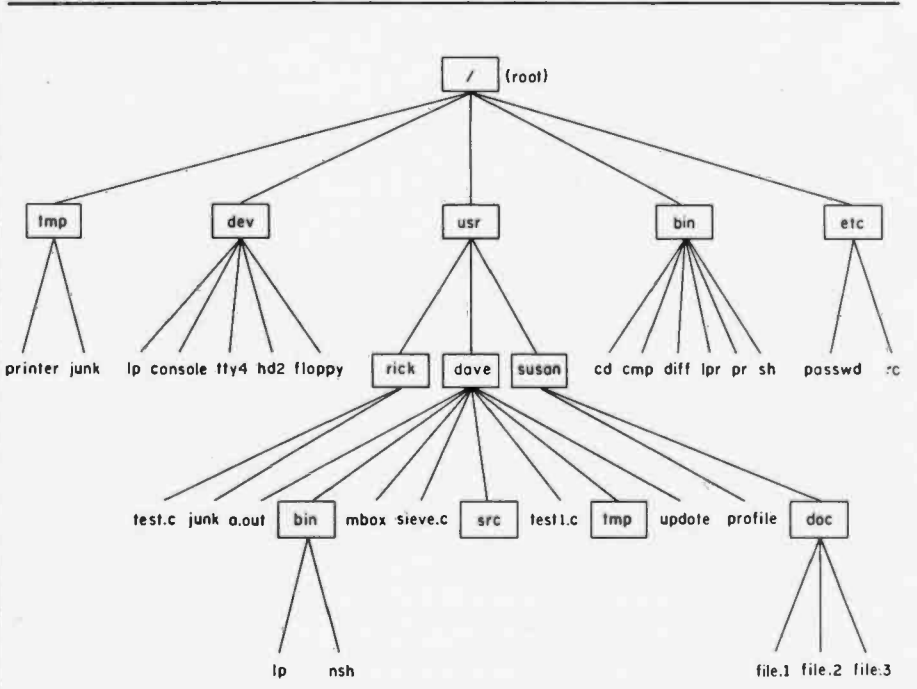

Figure 2: Part of a simple Unix file system. The hierarchical file structure organizes files and allows the use of the same file name within different directories. The directory files are symbolized with a block outline.

When the person administrating the Unix system initially sets it up, he or she can allocate more space to the /usr directory (and therefore the files under it) by setting up /usr as a logically separate file system. While this separate file system can physical-

ly reside on a distinct section of a disk (usually a Winchester disk or removable disk pack), it can also be on a totally different disk than the rest of the system; it can even take up an entire disk if needed. Not only can this allocation be changed later, it can

(800) 272-3360
TOLL FREE IN CALIFORNIA

**CALL FOR OTHER SOFTWARE
& HARDWARE PRICES FOR
IBM-PC & APPLE COMPUTERS**

(800) 292-3360
TOLL FREE OUTSIDE CALIF

MC-P APPLICATIONS

INTRODUCES SOFTWARE & HARDWARE AT UNBEATABLE PRICES

"WHY PAY MORE - COMPARE THESE PRICES"

LOTUS 1-2-3 \$325	WORDSTAR \$267	VISICALC \$165	MULTIPLAN \$168	dBase II \$395	HOME ACCOUNTANT \$49
----------------------------------	---------------------------	---------------------------	----------------------------	---------------------------	-------------------------------------

LIST OUR		LIST OUR		LIST OUR	
APPLIED SOFTWARE TECHNOLOGY		Account Receivable		MPC PERIPHERALS (APPLE)	
VersaForm	\$389 \$252	APPLE	400 237	Parallel Interface Card (w/cable)	90 63
VersaForm (hard disk)	495 323	IBM	600 355		
ASHTON TATE		Peach Pack	595 300	NOVATION	
dBase II	700 395	SOFTWARE PUBLISHING		Apple-Cat II	389 260
Financial Planner	700 452	Pfs:File		212 Auto Cat	695 561
BRODERBUND		APPLE	125 81	J-Cat	149 105
Bank Street Writer	70 46	IBM	140 91	Smart-Cat 103/121	595 416
CONTINENTAL		Pfs:Report	125 81	Smart-Cat 103	249 174
Home Accountant		SORCIM		PERSONAL COMPUTER PRODUCTS	
APPLE	75 49	SuperCalc	195 130	Appli-Card: 6MHz	375 265
IBM	150 96	Super Writer	295 195	Applicac: 4 MHz Applicard & Max 8 Cat. Card	620 334
Property Management	495 320	SYNAPSE		KRAFT Joystick	
HOWARDSOFT		File Manager	150 97	IBM	70 46
Real Estate Analyzer II		VISICORP		APPLE	65 42
APPLE	195 126	Visicalc	250 165	Paddle	50 33
IBM	250 162	VisiFile		T G PRODUCT Joystick	
Creative Financing		APPLE	250 165	IBM	65 42
APPLE	195 126	IBM	300 198	APPLE	60 39
IBM	250 162	VisiTrend/Plot	300 198	ELECTRONIC PROTECTION DEVICES	
LOTUS 1-2-3	495 325	VisiSchedule	300 198	Lemon	60 39
LIFETREE Volkswriter	195 129	VisiWnrd	375	Peach	98 63
MICROPRO		DeskTop Plan I	300 210	AST RESEARCH	
Word Star		HARDWARE			
APPLE	495 267	HAYES MICROCOMPUTER PRODUCTS		Megaplus 64K	395 330
IBM	495 295	Hayes Stack Chronograph (RS-232)	249 182	QUADRAM	
Spell Star		Hayes Stack Smart Modem (RS-232)	289 214	Quadboard 64K	395 285
APPLE	250 149	Smart Modem 1200 (RS-232)	699 511	Quad S12 + 64K	325 240
IBM	250 162	ADVANCED LOGIC SYSTEMS (APPLE II)		TANDON	
Mail Merge		Z-Card	169 110	TM 100-2 Drive	395 235
APPLE	250 135	PrinterMate (Parallel)	99 49	PRINTERS	
IBM	250 162	CP/M Card (with CP/M3.0)	399 300	Mennesman Tally MT 160L	798 645
Data Star	295 176	MICROSOFT		NEC 8023A	395
Super Sort	250 149	Softcard (APPLE)	345 242	Okidata 82A	410
Calc Star	145 86	Ram Card (APPLE)	100 70	Okidata 84	1019
Info Star	495 320	64-K Ram Card (IBM)	350 245	Okidata 92	499
Report Star	350 221	TERMS: All prices subject to change. Cashier's check / MO / Bank Transfer. Allow time for company or personal checks to clear. Prices reflect cash prepaid discount. VISA / MASTER CARD / COD / PO's + 3%. California residents add sales tax.		Okidata 93	875
MICROSOFT		SHIPPING: \$2 per item for UPS surface (\$6 for Blue Label) within con- tinental USA. Circle 251 on Inquiry card.		Gemini 10	399 305
Multi Plan				Panasonic KPX1090	550 435
APPLE	275 178			MONITORS	
IBM	275 168			Amdek 12" 310A	230 169
Flight Simulator	50 33			Amdek 12" 300A	199 155
PBL CORPORATION				Amdek Color I	399 291
Personal Investor	145 94			Amdek Color II RGB Hi-Res	529 425
PEACHTREE				Panasonic TR120 Green	220 165
General Ledger				Panasonic CT 160 Color	399 305
APPLE	400 237				
IBM	600 355				
Account Payable					
APPLE	400 237				
IBM	600 355				

MC-P APPLICATIONS, 111 W. St. John Street, Suite 230G, San Jose, CA 95113
HOURS: 8 a.m. to 5:30 p.m Monday thru Saturday Telephone (408) 293-3360

The Choice of

SAVE THIS AD IT IS YOUR CATALOG AND CHANGES MONTHLY

Computer Exchange — The Supply Center for the IBM-PC or XT

SOFTWARE for the IBM-PC or XT

SOFTWARE BUSINESS	LIST PRICE	OUR PRICE	
ASHTON-TATE dBase II, requires CP/M-86 & 128K	\$ 700	\$439	
dBASE II, requires PC-DOS & 128K	\$ 700	\$439	
The Financial Planner	NEW: \$ 700	\$439	
dBase II User's Guide by Software Banc	\$ 30	\$ 20	
Everyman's DB Primer (Book)	NEW: \$ 15	\$ 12	
Friday	NEW: \$ 295	\$199	
APPLIED SOFTWARE TECHNOLOGY Versatorm	\$ 389	\$265	
CONTINENTAL The Home Accountant Plus	\$ 150	\$112	
FCM (Filing, Cataloging, Mailing)	\$ 125	\$ 85	
Property Management	\$ 495	\$328	
DATAMOST Real Estate Investment Program	NEW: \$ 130	\$ 89	
Write-On-Word Processor Program	\$ 130	\$ 89	
DOW JONES Dow Jones Market Manager	\$ 300	\$239	
EAGLE SOFTWARE Money Decisions	NEW: \$ 150	\$129	
HAYDEN IBM Pe Writer	NEW: \$ 200	\$125	
HOWARDSON Real Estate Analyzer II	\$ 250	\$189	
INFORMATION UNLIMITED EasyWriter II (Word Processor)	\$ 350	\$259	
EasySpeller II (88K Words)	\$ 225	\$149	
EasyFiler (a DBMS)	\$ 400	\$299	
INNOVATIVE SOFTWARE TI Mill (a DBMS)	\$ 495	\$329	
INSOFT Data Design (a powerful easy to use DBMS)	NEW: \$ 225	\$169	
Data Base Made Easy (Book)	NEW: \$ 17	\$ 12	
IBM NameMagic	\$ 90	\$ 69	
★ LOTUS 1-2-3	NEW: \$ 495	\$329	
MICROCRRAFT Verdict (Legal) or Billkeeper, each IBM CP/M61	\$ 995	\$489	
★ MICRO LAB The Tax Manager	\$ 250	\$189	
MICROPRO WordStar plus free WordStar Training Manual	\$ 250	\$189	
Mail Merge™ (Call on 2 Pak, 3 Pak and others)	\$ 250	\$129	
SpellStar™	\$ 250	\$129	
WordStar Professional, 4 Pak, 3 above + Starindex	(Special) \$ 895	\$429	
Starindex™	NEW: \$ 195	\$109	
InfoStar™	\$ 495	\$269	
Report Star™	\$ 350	\$199	
★ MICROSOFT Multiphan	MSDOS	\$ 275	\$199
Multiflow Word	MSDOS	\$ 375	\$275
Multiflow Word with Mouse	MSDOS	\$ 475	\$350
Multiflow Financial	MSDOS	\$ 100	\$ 75
Multiflow Budget	NEW: \$ 150	\$115	
muLisp muStar	NEW: \$ 250	\$185	
muMath muSimp	NEW: \$ 300	\$225	
Business BASIC Compiler	MSDOS	\$ 600	\$450
Pascal Compiler	MSDOS	\$ 350	\$260
C Compiler	MSDOS	\$ 500	\$375
BASIC Compiler	MSDOS	\$ 395	\$295
Fortran	MSDOS	\$ 350	\$259
COBOL	MSDOS	\$ 750	\$559
BASIC Interpreter	MSDOS	\$ 350	\$259
★ NORTH AMERICAN BUS SYSTEM The Answer	\$ 250	\$189	
OSBORNE COMM. iBook & Desk Business, Statistics & Math Programs	\$ 100	\$ 69	
Some Common Basic Programs (70 programs)	\$ 100	\$ 69	
Practica Basic Programs (40 more programs)	\$ 145	\$ 99	
PBL CORPORATION Personal Utilities	\$ 595	\$365	
PEACHTREE SOFTWARE Peach Pak (GL, AR & AP)	\$ 389	\$219	
PERFECT SOFTWARE Perfect Writer™	\$ 295	\$129	
Perfect Speller™ or Perfect Calc™, each	\$ 595	\$259	
Perfect Filer™	\$ 595	\$339	
SELECT INFO. Se-edi (a WPS)	NEW: \$ 140	\$ 95	
SOFTWARE PUBLISHING PFS File	NEW: \$ 125	\$ 85	
PFS Report	\$ 295	\$199	
SORCIMA SuperCalc™	\$ 295	\$259	
SuperWriter	\$ 195	\$129	
Spe-guard	\$ 300	\$195	
STC The Creator	\$ 150	\$ 99	
SYNAPSE File Manager	\$ 250	\$189	
SYNERGISTIC Data Reporter	\$ 250	\$179	
★ VISICORP VisiCalc™ 256K	\$ 250	\$189	
VisiDex or VisiSchedule, each	\$ 300	\$219	
VisiTrend Plot	\$ 300	\$219	
VisiFile or Desktop Plan L, each	\$ 300	\$219	

UTILITY

★ CENTRAL POINT Copy II PC Backup and Utility	NEW: \$ 40	\$ 35
★ COMX Fasttrak™ RAM Disk emulator and printer spooler program. Works on many PC DOS version or RAM Card. Menu Driven.	NEW: \$ 100	\$ 69
DIGITAL RESEARCH Concurrent CP/M-86™	\$ 350	\$235
CBASIC 86™	\$ 200	\$135
CP/M 86	\$ 60	\$ 40
HAYES Smartcom II	\$ 119	\$ 89
MICROCOM Microterminal	\$ 100	\$ 65
MICROSTUF Crosstalk	\$ 195	\$129
NAGSYSTOMS Copy PC, Back and Utilities	\$ 35	\$ 25
NORELL DATA System Back	\$ 50	\$ 39
NORTON Norton Utilities 14 powerful programs 3 disks	\$ 80	\$ 55

HOME & EDUCATIONAL

EPXY Automated Simulations Temple of Ashkai Or Barons	\$ 40	\$ 29
ARMONK Executive Suite	NEW: \$ 100	\$ 75
BPI SYSTEMS Personal Accounting	\$ 40	\$ 27
BRODERBUND Apple Panic	\$ 195	\$139
CONTINENTAL The Home Accountant Plus	\$ 150	\$112
★ DATAMOST Pkg Pen or Space Strike, each	\$ 30	\$ 22
DAVIDSON The Speed Reader II	\$ 75	\$ 55
INFOCOM Deadline	\$ 50	\$ 39
Zork I or Zork II or Zork III, each	\$ 40	\$ 29
★ INSOFT Word Trek or Quatre or Mystic, each	NEW: \$ 35	\$ 28
MICROSOFT Flight Simulator (by Sub-logic)	NEW: \$ 50	\$ 35
SIERRA ON-LINE Lyrisses & The Golden Fleece	\$ 35	\$ 25
PBL CORP. Personal Investor	\$ 145	\$ 99
SIRIUS Conquest or Call to Arms, each	\$ 30	\$ 23
SIR-TECH Wizardry Scenario #1	\$ 60	\$ 40
SPINNAKER Snooper Traps #1 or #2, each	\$ 45	\$ 35
Story Machine or Face Maker, each	\$ 35	\$ 25
STRATEGIC The Warp Factor	\$ 40	\$ 30

IBM is a trademark of IBM Corporation.

IBM-PC

System Includes
Two 320K Disk Drives by CDC
90 Day Warranty By Us
Call For Details And Configurations

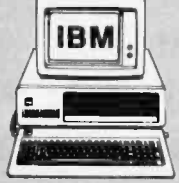

HARDWARE

MEMORY CHIP KITS	LIST PRICE	OUR PRICE
64K Kit, 200NS, 9 chips, 4154	\$ 150	\$ 99
16K Kit, 200NS, 9 chips, 4116 (for PC-1 motherboard)	\$ 30	\$ 16
★ AST Combo Plus 64K w/ async para & clock cal	\$ 395	\$ 279
Above Combo Plus, 128K, S P C	\$ 495	\$ 375
Above Combo Plus, 256K, S P C	\$ 695	\$ 525
★ ComX 256K RAM Card w/ Fasttrak™ RAM disk emulator and printer spooler software, 2 Year Warranty	\$ 750	\$ 625
CURTIS PC Pedestal™ for Display on PC	\$ 80	\$ 65
9 Foot Cable for IBM Keyboard (extends 3' to 9')	\$ 50	\$ 35
Key Tronic, KB5150, Standard Typewriter key locations	NEW: \$ 269	\$ 179
★ MICROSOFT 64K RAM Card w/ Parity	\$ 350	\$ 250
256K RAM Card w/ Parity	\$ 875	\$ 625
64K System Card, 4 Function	\$ 395	\$ 295
256K System Card, 4 Function	\$ 625	\$ 465
★ MBI Monte Carlo 64K Five Function (to 1000K)	\$ 625	\$ 395

★ QCS QUADRAM CORPORATION Big Blue, Z80 CPU plus five functions	\$ 595	\$ 449
★ Quadlink IBM to Apple II Link	\$ 680	\$ 580
Quadboard 64K, expandable to 256K, 4 function board	\$ 395	\$ 285
★ Quadboard 256K, four function board	\$ 595	\$ 425
Quad 512 - 64K plus serial port	\$ 325	\$ 275
Quad 512 - 256K plus serial port	\$ 550	\$ 440
Quad 512 - 512K plus serial port	\$ 895	\$ 675
Quadcolor I	\$ 295	\$ 235
Microfazer, w/ Copy Par, Par, 8K, #MP8 w/ Power Supply	\$ 189	\$ 139
Microfazer, w/ Copy Par, Par, 64K, #MP64 w/ Power Supply	\$ 319	\$ 235
Microfazer, w/ Copy Par, Par, 128K, #MP128 w/ Power Supply	\$ 465	\$ 345
Microfazer, Snap-on, 8K, Par, Epson, #ME8 w/ Power Supply	\$ 179	\$ 145
Microfazer, Snap-on, 64K, Par, Par, Epson, #ME64, w/ Pwr. Supply	\$ 319	\$ 235
All Microfazers are expandable (w/ copy to 512K) (Snap-on to 64K)		
TG PRODUCTS Joystick	\$ 65	\$ 49

DRIVES

Control Data or Tandon	1 each	2 or more
DISK DRIVES, Double Sided 360K 320K. Same as now supplied with IBM-PC & XT. Tested, burned-in. With installation instructions. 90 day warranty by us.	\$ 529	\$ 239
Hall Effect 360K or 320K Drives, same as above	\$ 395	\$ 199
★ DAVONG INTERNAL Hard Disk LIMITED SPECIAL	5-6MB \$1995	10-12MB \$2395
Power Supply & Controller	15-19MB \$2795	\$1895
MAYNARD, Floppy Drive Control Board, for up to 4 drives, same with Serial Port	\$ 195	\$ 165
same with Parallel Port	\$ 325	\$ 235
same with Parallel Port	\$ 275	\$ 205

PRINTERS AND ACCESSORIES

EPSON MX or FX PRINTERS	CALL	CALL
LEADING EDGE, Gonial Banana	NEW: \$ 250	\$ 209
PRACTICAL PERIPHERALS, Microbuiter In-Line 64K Parallel/Universal Buiter	\$ 349	\$ 259
Microbuiter In-Line 64K Serial Universal Buiter	\$ 349	\$ 259
★ STAR MICRONICS, 9x9 Dot Matrix, 100cps, 2.3K, Gemini 10"	\$ 499	\$ 349
9x9 Dot Matrix, 100cps, 2.3K, Gemini 15"	\$ 649	\$ 469
IBM-PC to Epson: Star Micronics Cable	\$ 40	\$ 35
Apple Interface and Cable for Epson or Gemini	\$ 95	\$ 59
Grappler - by Orange Micro, specify printer	\$ 165	\$ 119
Apple Graphics Dump Program by Epson	\$ 15	\$ 9
LETTERQUALITY - DAISY WHEEL PRINTERS		
COMREX Commander CR-1, 1 F, 200 wpm	Limited Special \$ 1189	\$ 645
Commander Tractor Feed for CR-1	\$ 118	\$ 99
SMITH-CORONA TPI Printer, specify serial or parallel I/F	Special \$ 899	\$ 499
TPI Tractor Feed	\$ 149	\$ 129
SUPPLIES: Tractor Feed Paper, Ribbons, Heads, Oume Daisy Wheels and Ribbons.		

ORDERING INFORMATION AND TERMS All Mail: P.O. Box 23068, Portland, OR 97223, Include telephone number. AD #976 means items usually in stock. We immediately honor Cashers Checks, Money Orders, Fortune 1000 Checks and Government Checks. Personal or Company Checks allow 20 days to clear. No C.O.D. Add 3% for VISA or MC. For U.S. Mainland, add 3% for shipping, insurance and handling (S&H) by UPS with \$5 minimum for S&H. UPS ground is standard so add 3% more for UPS Blue with \$10 minimum for S&H. Add 12% total for S&H for UPS Postal, APO or FPO with \$15 minimum for S&H. For Hawaii, Alaska and Canada, UPS is in some areas only, all others are Postal so call, write, or specify Postal. Foreign orders except Canada for S&H add 18% or \$25 minimum for S&H except for monitors add 30% or \$50 minimum for S&H. Prices subject to change and typo errors, so call to verify. All goods are new, include warranty and are guaranteed to work. Due to our low prices, ALL SALES ARE FINAL. Call before returning goods for repair or replacement. Orders received with insufficient S&H charges will be refunded. ORDER DESK HOURS 9 to 5 PST, Monday through Friday and 10 to 4 Saturday, 1 P.M. here is 4 P.M. in New York.

OUR REFERENCE: We have been in computers and electronics since 1958, a computer dealer since 1978 and in mail order since 1979. Banks: 1st Interstate Bank, (503) 643-4678. We belong to the Chamber of Commerce (503) 644-0123, Better Business Bureau (503) 227-0648, or call Dunn and Bradstreet if you are a subscriber. Conroy-LaPointe, Inc. is a division of O Tech Group, Inc. Fasttrak™ and Genetik™ are trademarks of ComX Corporation.

8" CP/M-80 BUSINESS & SYSTEM SOFTWARE - PARTIAL LIST, CALL

	LIST PRICE	OUR PRICE
ASHTON-TATE dBase II	\$ 700	\$ 439
INFOCOM Zork I or Zork II or Zork III or Starcross, each	\$ 59	\$ 39
MICROCRRAFT Verdict (Legal) or Billkeeper (Professional), each	\$ 995	\$ 469
MICROPRO WordStar™ plus free WordStar Training Manual	\$ 495	\$ 269
Mail Merge™ (Call on 2 Pak, 3 Pak and others)	\$ 250	\$ 129
SpellStar™	\$ 250	\$ 129
WordStar Professional, 4 Pak, 3 above + Starindex	\$ 895	\$ 429
InfoStar	NEW: \$ 495	\$ 269
ReportStar	NEW: \$ 350	\$ 199
★ MICROSOFT Multiphan	\$ 275	\$ 199
Fortran 80	\$ 500	\$ 325
BASIC Compiler	\$ 395	\$ 295
COBOL 80	\$ 750	\$ 545
BASIC-80 Interpreter	\$ 350	\$ 275
muLisp muStar-80	\$ 200	\$ 145
M-Sort-80	\$ 195	\$ 145
Edit-80	\$ 120	\$ 80
Macro-80	\$ 200	\$ 145

MONITORS AND ACCESSORIES

AMDEK 12" Green, #300G	\$ 200	\$ 159
12" Amber, #300A	\$ 210	\$ 159
★ 13" Color I, Composite	\$ 379	\$ 299
★ 13" Color II, RGB, Hi Res (Ap. II, III & IBM-PC)	\$ 529	\$ 459
★ 13" Color III, RGB, Commercial, (Ap. II, III)	\$ 479	\$ 399
DVM, Color II or III to Apple II Interface	\$ 199	\$ 175
NEC 12" Green, Model JB1201M	\$ 249	\$ 159
12" Color, Composite, Model JC1212M	\$ 450	\$ 349
PRINCETON, RGB Hi Res	\$ 795	\$ 539
QUADRAM, Quadochrome 12" RGB Color	\$ 795	\$ 565
SANYO, 9" Green, Model DM5109	\$ 200	\$ 139
12" Green, Model DM8112CX	\$ 260	\$ 199
13" Color, Composite, Model DM6013	\$ 470	\$ 349
TAXAN, RGB Vision 1, 380 Lines	\$ 350	\$ 339
ZENITH, 12" Green, Model ZVM121	\$ 150	\$ 99

MODEMS AND ACCESSORIES

AXLON, Datalink 1000 Hand Held Communications Terminal	\$ 399	\$ 295
HAYES, Microterm II (for the Apple II)	\$ 379	\$ 275
Apple Terminal Program for Microterm II	\$ 100	\$ 85
IBM-PC Smartcom II	\$ 119	\$ 89
Stock Chronograph (RS-232)	\$ 249	\$ 189
Smartmodem 300 (RS-232)	\$ 289	\$ 225
Smartmodem 1200 (RS-232)	\$ 699	\$ 535
Microterm 100 (S-100 bus)	\$ 399	\$ 275
IBM-PC to Modem Cable	\$ 39	\$ 29
MICROCOM, Micro Courier for Apple II	\$ 250	\$ 125
Micro Telegram for Apple II	\$ 250	\$ 125
NOVATION, Apple II Modem 300 BAUD	\$ 389	\$ 269
212 Apple Kit, 1200 BAUD	\$ 725	\$ 599
SIGNALMAN, Modem MK1 (RS-232)	\$ 99	\$ 79
SSM, Transcend 1 for Apple II Data Comm Modem Card for the Apple II	\$ 89	\$ 69
	\$ 299	\$ 259

★ CORVUS 5 Meg Hard Disk, w/o Interface	\$2395	\$1695
11 Meg Hard Disk, w/o Interface	\$3195	\$2695
20 Meg Hard Disk, w/o Interface	\$4195	\$3495
IBM-PC Interface (IBM DOS), Manual & Cable Kit	\$ 300	\$ 239
Mirror built in for easy backup	\$ 790	\$ 595
Apple Interface, Manual & Cable Kit	\$ 300	\$ 239
Other Interfaces: Omni-Net, Constellation, Mirror, All in Stock		

HP HP 75C Portable Computer, 48K, load to IBM PC	\$ 995	\$ 695
HP 41C Calculator	\$ 195	\$ 149
HP 41CV Calculator with 2.2K Memory	\$ 275	\$ 219
Full line of HP 75C and HP41 accessories & software	Call	

DISKETTES

CONTROL DATA CORPORATION Certified Top of the Line Diskettes		
CDC, 100 each, 5-1/4, with ring, SS, DD, 48T (Apple, IBM, etc.)	\$ 550	\$ 199
10 each, 5-1/4, with ring, SS, DD, 48T (Apple, IBM, etc.)	\$ 55	\$ 22
10 each, 5-1/4, with ring, DS, DD, 48T (IBM, H.P., etc.)	\$ 75	\$ 39
DYSAN, 10 each, 5-1/4, SS, SD, (Apple, etc.)	\$ 69	\$ 39
10 each, 5-1/4, DS, DD, 48T (IBM, H.P., etc.)	\$ 89	\$ 49
MAXELL, 10 each, 5-1/4, MD-1, SS, SD or SS, DD	\$ 55	\$ 35
★ GENERIK™ DISKETTES		
100 each SS, SD, 35 Track (Apple, Atari, etc.)	\$ 415	\$ 130
★ 1000 each SS, SD, 35 Track (Apple, Atari, etc.)	\$3200	\$ 995
100 each DS, DD, 40 Track (IBM, H.P., etc.)	\$ 626	\$ 160
★ 1000 each DS, DD, 40 Track (IBM, H.P., etc.)	\$4550	\$1200
With jackets, no labels, produced by a top of the line manufacturer. 90 day warranty by us		

★ Means a BEST buy #976

CASH & CARRY OUTLETS: Over-the-counter sales only. Open Monday through Saturday 10:00 until 5:00.
PORTLAND, OREGON, 11507-D.S.W. Pacific Hwy, Terrace Shopping Center, Tigard, OR 97144 between 217 and I-5. Call 245-1200.
SEATTLE, WASH., Grand Opening Soon. Call for location.

Professionals T.M.

LOW PRICES TO PROFESSIONALS WHO KNOW WHAT THEY WANT AND KNOW HOW TO USE IT.

apple II+/IIe supply center

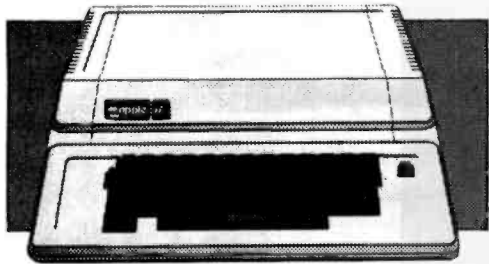

APPLE IIe 64K, 40 COLUMN	\$1,175
APPLE IIe 128K, 80 COLUMN	\$1,395
APPLE IIe STARTER SYSTEM BY APPLE (System A)	
64K and 80 column	
Disk II with controller	
Apple Monitor III	
Monitor Stand	\$1,695
APPLE IIe STARTER SYSTEM BY COMPUTER EXCHANGE (SYSTEM B)	
120" and 80 column	
1 micro-Sci Drive with controller	
File, Utility and DOS 3.3 Diskette	
Sanyo 9" Green Monitor	
RF Modulator (for color TV)	
Game Paddles	
Game with color graphics and sound	\$1,875
WARRANTY is 100% Parts and Labor for 90 days by us.	
To substitute or delete drive on System B, subtract \$245 and add drive price (System D)	
To add on Micro-Sci A2 Drive to above, add \$245. (System DD)	
To substitute or delete monitor on System B, subtract \$130 and add other monitor price (System M).	

DISK DRIVES for APPLE II+ /IIe	
U-SCI	A2, 5-1/4", 143K Disk Drive \$ 479 \$ 249
	Controller Card for A2 Drive \$ 100 \$ 79
MICRO-SCI	★A40, 5-1/4", 160K Disk Drive \$ 449 \$ 299
	★A70, 5-1/4", 286K Disk Drive \$ 599 \$ 299
	Controller for A40 or A70 \$ 100 \$ 79
	File, Disk Utility Software \$ 20 \$ 15
VISTA	Solo, 5" 143K Disk Drive \$ 300 \$ 249
	Std. Height \$ 420 \$ 329
	Half Height \$ 715 \$ 575
	Quartet, 5", 2 Duets Side by Side or Standard Cabinet \$ 89 \$ 75
	Controller Card \$2195 \$1295
	★V1000 Dual 8", Std. Format w/Controller, Complete \$ 379 \$ 279
TEAC	★143K Disk Drive, 1/2 High \$ 89 \$ 69
	Controller Card \$ 20 \$ 15
	★CENTRAL POINT, File, Utility and DOS 3.3

HARDWARE for Apple II

RAM EXPANSION	
★ ComX, for IIe, 80 col. 64K Adder Card	\$ 295 \$145
★ ComX, RAM Card, 2 Yr. Wty. (II -) 16K	\$ 179 \$ 39
★ ALS, ADDPain (II -) 16K	\$ 100 \$ 69
★ Microsoft, RAM Card (II -) 32K	\$ 100 \$ 79
★ Saturn Systems, RAM Card (II -) 32K	\$ 249 \$169
	HAM Card (II -) 64K \$ 425 \$319
	HAM Card (II -) 128K \$ 599 \$459
★ Axlon RAM Disk System (- ore) 320K	\$1395 \$795

VIDEO CARDS	
★ ALS, Smartem II (- ore)	\$ 179 \$139
ComX, 80 col. 64K Adder (Ile)	\$ 295 \$145
Videx Videoterm 30 col (- ore)	\$ 345 \$229
★ UltraTerm (- ore)	\$ 379 \$279
Soft video Switch (II -)	\$ 35 \$ 25
Enhancer II (II -)	\$ 149 \$ 99
Function Strip (II -)	\$ 79 \$ 59
Full Videx Line, Call. Up to 35% off.	
Vista, Vision 80	\$ 289 \$199

MISCELLANEOUS	
ALS, The CP/M Card V3 0 (- ore)	\$ 399 \$299
Z-Card (- ore)	\$ 169 \$129
Color II (- ore)	\$ 179 \$139
ASTAR, RF Modulator	\$ 35 \$ 25
CCS, Serial Interface 7710A	\$ 150 \$129
Dan Paymar, Lower Case Chip (II -)	\$ 50 \$ 39
Don's Ask, DAG 003 S A Mount	\$ 125 \$ 85
★ Eastside, W/C Card, copier	\$ 100 \$ 99
Kensington, System Saver	\$ 90 \$ 69
Key Tronic, KB200 keyboard.	
84 keys (II -)	\$298 \$198
Krah, Joystick (Ap II) (-)	\$ 65 \$ 49
Paddie (Ap II) (-)	\$ 50 \$ 39
M&R, Sup Rlan	\$ 50 \$ 39
★ Microsoft, 280 Softcard (- ore)	\$ 345 \$235
280 Softcard Plus (- ore)	\$ 645 \$459
Softcard Premium Pack (II -)	\$ 695 \$495
Softcard Premium Pack (Ile)	\$ 495 \$395
Micro Tek, Dumping 64, Buffer	\$ 349 \$269
★ Orange Micro, Grappier Plus	\$ 165 \$119
Practical Peripherals.	
MBP Ite 64K Par. (Epson Internal) (- ore)	\$ 279 \$209
MBS Ite 32K Ser. (Epson Internal) (- ore)	\$ 219 \$169
Microbuffer II - , 16K, (- ore)	
Par Ser (specify)	\$ 259 \$199
Microbuffer II - , 64K, (- ore)	
Par Ser (specify)	\$ 349 \$259
PCPI, Appl. Card, 14 features 4 Mhz	\$ 295 \$235
6 Mhz	\$ 375 \$275
RH Electronics, Super Fan II	\$ 75 \$ 59
★ Saturn Systems, Accelerator II	\$ 599 \$449
SSM, A10 II, Serial Para Interface	\$ 225 \$169
TG Products, Game Paddles (II -)	\$ 40 \$ 29
Joystick (II -)	\$ 60 \$ 45
Select-A-Port (II -)	\$ 60 \$ 45
Trak Ball (II -)	\$ 65 \$ 44
Videx, PSIO, Para Ser Interface	\$ 229 \$169
W/C, Trackball (Ap II) (-)	\$ 90 \$ 61
Analog Joystick	\$ 70 \$ 47

SOFTWARE on disk for Apple II/II+ /IIe

BUSINESS	
Apple Computer, Inc. 50% off list. on Apple Inc. software	Call
Applied Soft Tech., VersaForm	\$ 389 \$265
Artsoft, MagicWindow II NEW!	\$ 150 \$ 99
Ashlon-Tate, dBase II (CP/M)	\$ 700 \$439
Financial Planner	\$ 700 \$439
User's Guide by Software Banc	\$ 30 \$ 20
BPI Systems, GL, AR, AP, PR or INV, each	\$ 395 \$295
Job Cost	\$ 595 \$435
Broderbund, Bank Street Writer	\$ 70 \$ 47
Continental, GL, AR, AP or PRea	\$ 250 \$169
Home Accountant	\$ 75 \$ 49
FCM	\$ 100 \$ 66
Dow Jones, Market Analyzer	\$ 300 \$239
Hayden, Pie Writer (Specify brd.)	\$ 150 \$ 99
Howard Soft, Real Estate Analyzer II	\$ 195 \$129
Text Preparer	\$ 225 \$149
Info. Unim., Easywriter (PRO)	\$ 175 \$119
LJK, Letter Perfect w/ Mail Merge	\$ 150 \$ 99

★ Micro Craft, (requires Z80 CP/M Card)	\$ 995 \$469
Professional Billkeeper	\$ 995 \$469
Verdict, (Legal Billing)	\$ 180 \$119
★ Micro Lab, Tax Manager	\$ 180 \$119
Micro Pro, (all require Z80-CP/M Card)	
WordStar* + Training Manual	\$ 495 \$269
MailMerge*	SPECIAL \$ 250 \$129
SpellStar*	SPECIAL \$ 250 \$129
WordStar Professional 4 Pak.	
3 above + Star Index	SPECIAL \$ 895 \$429
WordStar w/Applicard & CP/M (special)	\$ 495 \$345
Microsoft, Multi-Plan (CP/M or Apple DOS)	\$ 275 \$199
Financial, Multitool (CP/M or DOS)	\$ 100 \$ 75
Budget, Multitool (CP/M or DOS)	\$ 150 \$115
Sierra On-Line, ScreenWriter II	\$ 130 \$ 89
The Dictionary	NEW! \$ 100 \$ 69
General Manager II	NEW! \$ 230 \$165

Osborne, C.P. Soft, (Disk and Book)	
Some Common Basic Programs (75 each)	\$ 100 \$ 49
Statistics and Main Programs	\$ 100 \$ 49
Practical Basic Programs (40 each)	\$ 100 \$ 49
Peachtree, Requires CP/M & MBasic, 40 columns	
Series 40 GL & AR & AP, all 3	\$ 595 \$395
Series 40 Inv. or Pay, each	\$ 400 \$275
Series 9 Text & Spell & Mail, all 3	\$ 595 \$395
Perfect, Perfect Writer	\$ 495 \$219
Perfect Speller	\$ 295 \$129
Perfect Writer/Speller 2 Pak	\$ 695 \$299
Perfect Filer	\$ 595 \$259
Quark, Word Juggler (Ile)	\$ 239 \$179

Sensible, Sens. Speller, specify version	\$ 125 \$ 85
★ Silicon Valley, Word Handler	\$ 250 \$139
Soft Sys., Executive Secretary	\$ 250 \$169
Executive Speller	\$ 75 \$ 55
Software Publishing, PFS: File	\$ 125 \$ 85
(specify - ore) PFS: Report	\$ 125 \$ 85
PFS: Graph	\$ 229 \$155
Stoneware, DB Master	\$ 99 \$ 69
DB Utility I or II	\$ 687 \$387
DB Master 3 Pak, Special	\$ 20 \$ 15
Videx, Applewriter II preboot disk	\$ 50 \$ 39
Visicalc 80 col. preboot disk	\$ 90 \$ 69
Videx 80 col. to 176K disk	\$ 37 \$ 28
VisiCorp Personal Software.	
Visicalc 3.3	\$ 250 \$169
Visicalc Enhanced (Ile)	NEW! \$ 250 \$169
VisiFile or VisiDex, each	\$ 250 \$169

UTILITY & DEVELOPMENT	
Beagle, Utility City	\$ 30 \$ 22
DOS Boss	\$ 24 \$ 18
Apple Mechanic	\$ 30 \$ 22
Central Point, Filter, DOS Utility	\$ 20 \$ 15
Copy II Plus (bit copier)	\$ 40 \$ 35
★ Computer Appl., Nibbles Away II	\$ 70 \$ 59
Epson, Graphics Dump	\$ 15 \$ 9
Insoft, GrafPORT by Paul Lulus	\$ 75 \$ 59
Microsoft, A.L.D.S.	\$ 125 \$ 75
BASIC Compiler	\$ 395 \$299
Bobol 80	\$ 750 \$559
Fontan 80	\$ 195 \$149
TASC Compiler	\$ 175 \$159
★ Omega, Locksmith (bit copier)	\$ 100 \$ 75
Penguin, Comp. Grphcs Sys.	NEW! \$ 70 \$ 53
Graphics Magician	NEW! \$ 60 \$ 41
Phoenix, Zoom Grafix	\$ 40 \$ 34
Quality, Bag of Tricks	NEW! \$ 40 \$ 29
Saturn Systems, VC-Expand	\$ 100 \$ 49
VC-Expand 80	\$ 125 \$ 69
Sensible, Back It Up, (bit copier)	\$ 60 \$ 49

HOME & EDUCATION	
Broderbund, ChopPletter	\$ 35 \$ 26
Budge Co, Pinball Constr. Set	\$ 40 \$ 27
Continental, Home Accountant	\$ 75 \$ 49
Dalamosi, Artex or Zaxxon, each	\$ 40 \$ 27
Edu-Ware, (Large Inventory)	Call
Hayden, Sargon II (Chess)	\$ 35 \$ 29
Infocom, Zork I, II, or III, or Starcross, each	\$ 40 \$ 27
Deadline	\$ 50 \$ 34
Lightning, Mastertype	\$ 40 \$ 27
Micro Lab, Miner 2049er	\$ 40 \$ 27
Muse, Castle Wolfenstein	\$ 30 \$ 23
Sierra On-Line, Ultima II	\$ 60 \$ 40
Solporm (X Rated)	\$ 35 \$ 22
Str. Tech, Wizardry	\$ 50 \$ 39
Sub Logic, Flight Simul	\$ 34 \$ 25
OTHER BRANDS AND PROGRAMS IN STOCK. CALL.	

WHILE THEY LAST OVERSTOCK SPECIALS FOR APPLE II/II+ /IIe	
★ ALS, Synergizer + Supercalc + Condor (for II +)	\$ 749 \$399
Anadex, DP9000, Dot Matrix Printer	\$ 995 \$395
CCS, Serial Interface 7710A	\$ 150 \$129
★ Com X, 16K RAM Card, 2 Yr. Warranty, for II +	\$ 179 \$ 99
M&R, SupRterm 80 col. for II +	\$ 375 \$199
MicroCom, Micro Courier	\$ 250 \$125
Micro Telegem	\$ 250 \$125
Micro-Sci, A70, 5 1/4" 286K Disk Drive	\$ 599 \$299
Microsoft, 16K RAM Card (for II +)	\$ 100 \$ 79
Saturn Systems, 32K RAM Card (for II +)	\$ 249 \$169
Silicon Valley, Word Handler	\$ 250 \$139
Videx, Videoterm, 80 column card (for II +)	\$ 345 \$229

SYSCOM II Apple II+ Work-a-like	
Note: Substitutions and deletions same as System B apply. Syscom 2 is software and hardware compatible to the Apple II +.	
Syscom 2, 64K (Apple II + Compatible)	\$ 869 \$559
Syscom 2, 64K Starter System (same as Apple IIe System B above except 64K, 40 columns)	\$1810 \$1195

AXLON The Leader in Atari Add-ons	
ATARI Rampower 128K System (800)	\$ 475 \$295
Rampower 48K Module (for 400)	\$ 185 \$115
Rampower 32K (400 or 800)	\$ 120 \$ 59
Ramscan Diagnostic Diskette	\$ 15 \$ 12

★ Means a BEST buy.

AD #976



NATIONAL ORDER DESK	TOLL FREE
(800) 547-1289	
All Other Orders Including Portland: 245-6200	
Oregon TOLL FREE (800) 451-5151	Hot Line For Information On Your Order (503) 245-1030

CONROY-LA POINTE

Formerly Computer Exchange T.M.

ALL MAIL: P.O. Box 23068, Portland, OR 97223
SHOWROOM AT 11507D SW PACIFIC HWY., PORTLAND, OR, OPEN M-SAT 10-5

Circle 89 for IBM Peripherals, Circle 90 for Apple, Circle 91 for all others.

console	—the system console terminal
fd0	—floppy disk 0
fd1	—floppy disk 1
hd0	—hard disk 0
hd1	—hard disk 1
kmem	—kernel memory
lp	—line printer
mem	—user memory
null	—null device (bit bucket)
phone	—telephone dialer (sometimes called acu)
rfd0	—“raw” access to floppy disk 0
rfd1	—“raw” access to floppy disk 1
rhd0	—“raw” access to hard disk 0
rhd1	—“raw” access to hard disk 1
tty0	—“teletype” 0—a user terminal or modem
tty1	—“teletype” 1—a user terminal or modem
tty2	—“teletype” 2—a user terminal or modem
tty3	—“teletype” 3—a user terminal or modem

Table 1: A typical listing of the files in the `/dev` (device) directory with descriptions of each device.

Listing 2: A typical directory listing for a user on a Unix system employing the list directory (`ls`) command with the `-l` (long form) option.

```

$ ls -l
-rwxr-xr-x 1 dave      8696 Mar 26 18:53 a.out
drwxr-xr-x 2 dave       80 Oct  4 17:02 bin
-rw-rw---- 1 dave     576 Oct 12 21:33 mbox
-rw-r--r-- 1 dave     904 Oct 21 15:46 sieve.c
drwx----- 2 dave     149 Oct  4 17:02 src
-rw-r--r-- 1 dave      79 Oct 21 15:46 test1.c
drwxrwxrwx 2 dave      48 Mar 26 18:55 tmp
-rwxr--r-- 1 dave    3508 Nov 23 13:11 update
$

```

also be done *at any level* of the file system. This means that one of your lowest-level subdirectories can be reassigned to reside on another device, expanding theoretical storage space almost ad infinitum (each file can contain almost 2^{30} bytes, and thousands of files are possible on a system).

I/O Independence

The I/O (input/output) system on Unix is easy to understand. Every physical device supported by the system appears, like a file, as an entry in the `/dev` (device) directory. Users and programs running on Unix handle the devices as if they actually were files. A typical listing of the files in the `/dev` directory might look similar to the left-hand column of

table 1 (descriptions of each device are on the right).

Notice that every physical resource on the system is accessed as if it were a regular file, even memory itself. To send characters to the line printer, you just issue a system write command to the file `/dev/lp`. If you want to debug a new disk device driver you can read, say, the file `/dev/rhd1`, which will show you exactly what's on a particular hard disk in “raw” form (i.e., not under control of the file system). Changing one byte in memory would involve writing the byte to `/dev/mem`.

While users can treat devices like files, to the Unix system programmer they are still devices, which must have device-driver programs written for them so they can communicate

with the system. The device drivers are loaded into `/unix`, the executable code that is the actual operating system, before you receive your Unix-equipped computer. Because the operating system must access devices through these driver programs, the devices are also known as *special files*. Depending on how information is passed to or from the device, these are either character special files or block special files. Generally, devices such as modems, terminals, and printers are considered character-by-character devices, while disks and tape drives are usually treated as block-by-block devices because they transfer data in larger blocks of 512 or 1024 bytes for efficiency.

File Security

Naturally, some control must be exercised over devices and files. Several people trying to write to the printer at once would result in confused program listings, and letting just anyone write to random spots in memory would soon crash the system. In addition, you wouldn't want other people to be able to read or erase your personal files. Unix provides this control in a simple but effective way. Each file has an associated group of protection bits (also known as mode bits), which the owner of the file can control individually.

The values of these bits may be seen for any file on Unix by executing the `ls` list directory command with the `-l` (long form) option. Listing 2 shows a typical directory listing. If a bit is set (turned on, or enabled) its value is visible; otherwise, you simply see a hyphen.

The 10 bits shown for each file include a directory bit (`d`—not actually a protection bit), 3 “user” protection bits (`rwx`, for read, write, and execute), 3 “group” protection bits (`rwx`), and 3 “other” protection bits (`rwx`). An enabled directory bit means that the file in question is a directory. The three sets of protection bits tell how the *user* (owner of the file), his or her working *group* (a collection of other people wishing to share file access for a project), or all *other* system users can access the file. When the



DAWN OF A NEW GENERATION

RELIANT • EFFICIENT • UPGRADABLE

CMC 8/16 SUPERSYSTEM II

- TurboDOS*, CPIM** and CPIM-86** operating systems
- Floppy and hard disk drives
- SuperNet, local area networking, accommodates up to 16 users with 6 MB to 52 MB storage
- All stand-alone models utilize 750K to 19 MB storage and can be field-upgraded to SuperNet status
- All 8-bit SuperSystems are easily upgraded to our new 8/16-bit system which features Intel's 80186 Processor and full CPIM-86 compatibility
- "Perfect Writer" word processing standard with all models
- Generous dealer and OEM discounts
- 6 month warranty
- National on-site service in over 150 cities

CMC International

1720 130th Avenue N.E.
Bellevue, Washington 98005
(206) 885-1600 Telex 152556 SEATAC

*TurboDOS is registered Trademark of Software 2000
**CPIM is a registered Trademark of Digital Research, Inc.

Circle 72 on Inquiry card.

read or write bit is enabled for one of these groups of bits, a user belonging to that group is permitted read or write access. When the read bit, but not the write bit, is set, you cannot add to, change, or destroy the file. This kind of protection is usually used for data files accessible to all, such as the system header files any C programmer might need. If the write bit, but not the read bit, is set, you have a "write-only" file. This is handy for creating system accounting log files where information about what people do on the system is kept. It may not be desirable to allow such information to be available to all users. When the execute bit is enabled, it means that the file may be executed as a program because it's either object code or a Shell program (I'll explain more about this later).

The significance of these bits is slightly altered when applied to directories. If the write bit is enabled for a directory, it means that files may be created or deleted in the directory. When the execute bit is turned on, you may then search through the files in the directory and read, write, and execute these files if permitted by the protection bits on the files themselves. If only the read bit is enabled, you may simply read the directory as a file, and you have limited access to the names of the files and their pointer information. The system administrator or *super-*

user can bypass all file protections.

Because only an owner of a file or the super-user may change the values of these bits with the `chmod` command, the security on Unix is as good as users wish it to be. The `umask` command allows you to set the default protection for all files you create, from `rw-----` for the suspicious to `rw-rw-rw-` for the trusting.

Redirection and Pipes

Most people who regularly run programs on computer systems don't concern themselves with where the program input comes from—usually it comes from their terminal, another predefined device such as a tape drive, or a dedicated data file.

File security in Unix is almost entirely up to each user.

Similarly, the output of a program is generally expected to end up on their terminal, in a new data file, or on the system printer. On Unix, you can easily arrange for your programs to get their input from any file or device you have access to (and it's equally easy to redirect output). Let's look at how Unix handles this procedure and you'll wonder why other operating systems weren't set up to

do it this way.

Remember that devices are treated as files, and so to send a directory listing to the printer, you just type the following:

```
$ ls > /dev/lp
$
```

The "greater than" (>) character sends the output of the `ls` command (which would normally print a list of files on your terminal) to the system printer. The dollar sign (\$) is the Unix prompt character (some versions of Unix use the percent sign (%) for the same purpose).

Input to a program can be controlled in a similar way. For example, if a file on the disk called `textfile` contains a list of words, we can find the spelling errors in the file and have them appear on the terminal with the command

```
$ spell < textfile
```

The "less than" (<) character redirects the input of the `spell` command to come from the disk file (notice the mnemonic nature of the characters used: each one points in the direction of data transfer).

Where would input normally come from? The typical Unix program has one source of input and only one type of output. Such a program is known as a *filter* if it simply accepts

RADIO SHACK COLOR COMPUTER MODEM COMMUNICATIONS

Make your Color Computer an intelligent printing terminal with off-line storage!

- Talk to a timeshare system or information service
- Print out what is received as it is received
- Save received text to cassette tape
- Re-display the received text even while on-line
- Communicate with other computers
- Using your computer as a general-purpose 300-baud terminal
- Downloading programs from other computers

The Microtext module is a program pack containing not only firmware but a second serial port so that both your printer and modem can be connected at the same time. Microtext can be configured for any serial printer that will work with the Color Computer, even if it requires line feeds! But even if you don't have a printer, you can keep a permanent copy of your data by storing to cassette tape. Also, any Radio Shack/Centronics-compatible parallel printer may be used by adding the Micro Works' P180C parallel interface.

For those of you with special terminal applications, Microtext has selectable parity; it sends odd, even, mark or space. With mark parity (which is default) you can send to computers requiring either seven or eight bits. All 128 ASCII codes can be sent. Exchange programs with other Color Computer users! Basic programs may be downloaded from other computers or timesharing systems.

You'll find many uses for this versatile module! Available in ROMPACK, ready-to-use, for \$59.95

PLUS

First-rate Programming Tools • Books • Games • Memory Upgrade Kits
Hardware • Keyboards • Parts

THE **MICRO WORKS**

P.O. BOX 1110 DEL MAR, CA 92014 619-942-2400

May we interrupt the hoopla with a few facts?

Nothing in the noisy world of multi-user micros fits the requirements of business system integrators like our new desktop system — the MuSYS NET/work 8816™.

The MuSYS NET/work gives you multiprocessor architecture, extensive mass storage facilities (much greater than 8MB) and TurboDOS™, the high speed CP/M® compatible operating system. Gone are the bottlenecks that make shared-processor multi-user systems too sluggish for real world business applications. You'll also appreciate the 128K RAM per user,

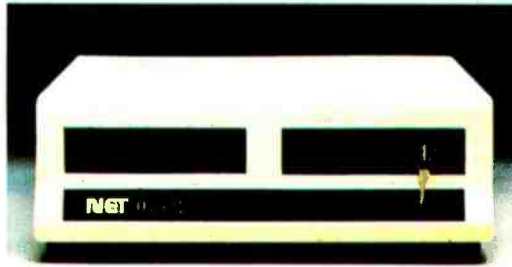

the local area networking capability (including Ethernet™), log-on security and other mainframe-like features that make the NET/work a truly professional, reliable business solution. Dealer and OEM customization programs available.

Get all the down-to-business facts! Call or write, MuSYS Corporation, 1752 Langley, Irvine, California 92714. (714) 662-7387 (toll-free outside California 1-800-852-5362). TWX: 910-595-1967. Cable: MUSYSIRIN.



We design the future.

The facts:	MuSYS NET/work 8816 ¹	ALTO 8000-10	Televideo 806/20	Micromation Mariner
No. users (min/max)	2/8	4/4	1/6	1/8
Winchester formatted Mbytes (min/max)	16/102	10/20	15/30	20/40
Total RAM per user	128K	48K	64K	64K
User TPA	63.5K	48K	54K	62K
8- and/or 16-bit user processors	YES	NO	YES	NO
Perfect Software ¹	YES	NO	NO	NO
Telecommunications Software	YES	NO	NO	NO
Operating system ¹	Turbo-DOS	MP/MII	Mmm-OST	M/NET
Use with any terminal	YES	YES	NO	YES
Price (2 user system)	\$7,495 ²	\$7,490	\$10,785 ³	\$13,400

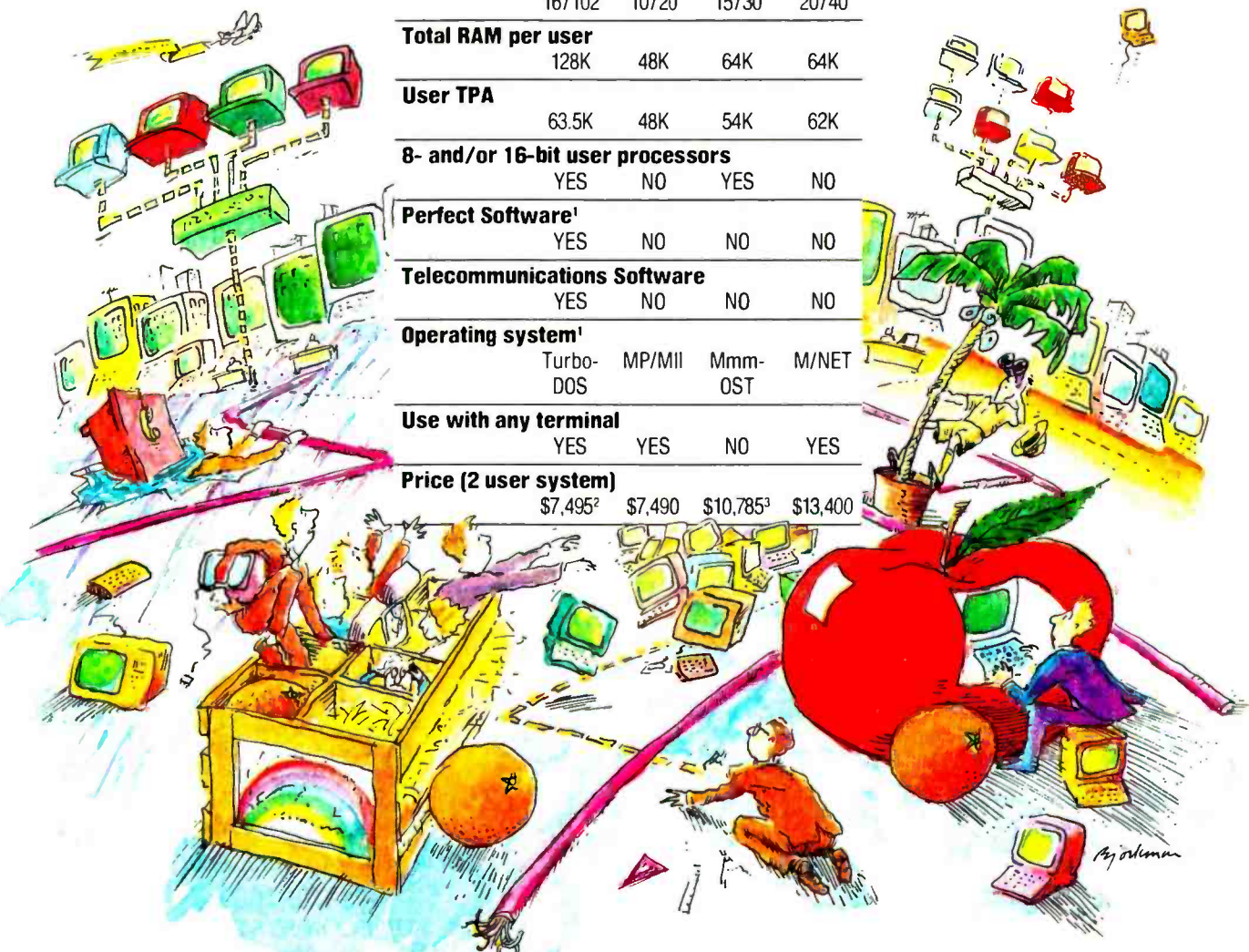

¹ NET/work 8816 is a trademarked product of MuSYS Corporation. Perfect Software is a trademarked product of Perfect Software, Inc. TurboDOS is a trademarked product of Software 2000, Inc. CP/M® and MP/MII are trademarked products of Digital Research, Inc. Mmmost is a trademarked product of Televideo. M/Net is a trademarked product of Micromation. Ethernet is a trademark of Xerox Corp. ² 8-User network is \$11,995. MuSYS prices include 16 MB formatted Winchester. ³ Includes terminals.

its input, performs some function on it, and emits the processed data as output. The system causes the default, or *standard*, input and output "files" to be the user's terminal unless otherwise redirected. So, for example, you can redirect the output of `ls` to a file in the following manner:

```
$ ls > temp
$
```

Now if you look at the file `temp`, you'll see the names of the files in your directory. The all-purpose program `cat` (short for concatenate) can be used to collect several files and put them all together. In the following example we'll simply use `cat` to show the contents of `temp` without formatting, using the directory from listing 2:

```
$ cat temp
a.out
bin
mbox
sieve.c
src
temp
test1.c
tmp
update
$
```

Notice the file `temp` you just redirected input to is listed as being in the directory. Redirecting input to a file creates the file if it didn't exist or erases it and creates it anew if it did exist. This is done before running the program that is having its input redirected; so when `ls` executed, it

picked up the `temp` file from the directory. Using the operator twice (`>>`) signals that you wish to add to the end of the file if it exists; this is useful for collecting data. If you now want to print out all the C source files, start each on a separate page, include page numbers, the date each file was last modified, and the name of each file, then the `pr` program will do this:

```
$ pr *.c
Oct 21 15:46 1982 sieve.c Page 1
/* Eratosthenes Sieve
Prime Number Program in C */
#define true 1
#define false 0
#define size
(interrupted)
$
```

Note that the almost universal wild-card character, the asterisk (*), is used to represent all files with a `.c` extension. But the `pr` program, like most others, sends its output to the terminal, and you wanted the printer. So for a printed listing, you have to redirect the output of `pr` to the printer (`/dev/lp`). However, on most Unix systems, users are not permitted to write directly to the printer (check the protection bits on your system), but must use something called the line printer spooler program. This program (called `lpr` on most systems) accepts as input whatever you want to print, writes it to a temporary file, and begins printing. This way, you can start a print job that might take an hour to finish, but the `lpr` program will return to you as soon as it's

finished copying your files, so you can continue working. Now if you say

```
$ lpr *.c
$
```

you get your prompt back almost immediately, and meanwhile the files are being printed. But when you look at them, you find both files are printed one after the other, with no page numbers or even expansion of tab characters. You really wanted `pr` to format them, so you can do this:

```
$ pr *.c > temp1
$ lpr temp1
$
```

Now we formatted the output properly, sent it to a file, then printed the file. We are also starting to leave files around to mess up our directory. Besides, this is a lot of typing. A better way would be to pass the output of `pr` directly to the input of `lpr`. So that's exactly what we do:

```
$ pr *.c | lpr
$
```

The vertical bar (|) looks somewhat like a pipe, and is called a pipe because the connection between programs is very much like a plumbing connection. At first it would seem that the pipe is simply an elegant notation for sending the output of `pr` to a temporary file, redirecting the input of `lpr` from that file, then erasing the file. In Unix, all programs in a pipeline actually run *simultaneously*

C compilers

- FULL C
- UNIX* Ver. 7 COMPATABILITY
- NO ROYALTIES ON GENERATED CODE
- GENERATED CODE IS REENTRANT
- C AND ASSEMBLY SOURCE MAY BE INTERMIXED
- UPGRADES & SUPPORT FOR 1 YEAR

C SOURCE AVAILABLE FOR \$2500⁰⁰

408-275-1659

TELECON SYSTEMS
1155 Meridian Avenue, Suite 218
San Jose, California 95125

HOST	6809 TARGET	PDP-11*/LSI-11* TARGET	8080/(Z80) TARGET	8088/8086 TARGET
FLEX*/UNIFLEX* OS-9*	\$200.00 \$350.00	500.00	500.00	500.00
RT-11*/RSX-11* PDP-11*	500.00	200.00 350.00	500.00	500.00
CP/M* 8080/(Z80)	500.00	500.00	200.00 350.00	500.00
PCDOS*/CP/M86* 8088/8086	500.00	500.00	500.00	200.00 350.00

*PCDOS is a trademark of IBM CORP. MSDOS is a trademark of MICROSOFT. UNIX is a trademark of Bell Labs. RT-11/RSX-11/PDP-11 is a trademark of Digital Equipment Corporation. FLEX/UNIFLEX is a trademark of Technical Systems consultants. CP/M & CP/M86 are trademarks of Digital Research. OS-9 is a trademark of Microware & Motorola.

PRESENTING THE S100-PC™ FOR \$2999.

**The S100-PC by Lomas Data Products:
Offering high performance at a "low" price...
and it's IBM-PC diskette compatible.**

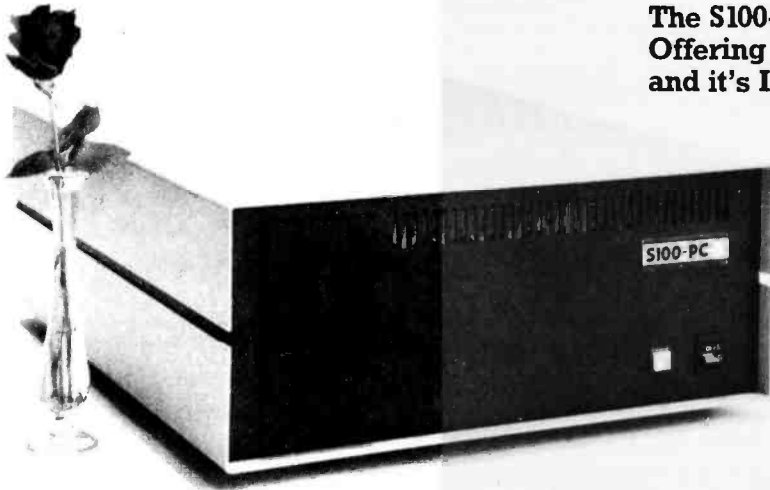

The S100-PC is a cost effective high performance floppy based system ideally suited to business and scientific applications.

The system offers the following standard features:

- Two 5¼" double sided disk drives (640 Kbytes of storage)
- Two serial ports, Two parallel ports
- Battery protected clock calendar
- MS-DOS** operating system (others optional)
- 128K RAM
- 8 MHZ 8088 processor (8087 optional)
- 15 slot S100 mother board
- Attractive desktop enclosure

And, the S100-PC is diskette compatible with the IBM-PC and most programs will operate without any changes. Plus, with its S100 bus expansion capability... your system will never be outdated.

S100 bus board products & support for the system integrator...

■ **LIGHTNING ONE *** 8086/8088 CPU**
8086 or 8088, with 8087 and 8089 coprocessors. Up to 10MHZ operation **PRICES start at \$425.00**

■ **HAZITALL SYSTEM SUPPORT BOARD**
2 serial, 2 parallel ports, battery protected clock calendar, Hard disk controller host interface **PRICE \$325.00**

■ **LDP128/256K DYNAMIC RAM**
Advanced dynamic RAM with LSI controller for failsafe operation, parity **Price 128K — \$495.00, 256K — \$795.00**

■ **RAM67 HIGH PERFORMANCE STATIC RAM**
High speed (100ns) low power CMOS static RAM. 128K bytes, extended addressing **PRICE \$1200.00**

■ **LDP72 FLOPPY DISK CONTROLLER**
Single/double density, single/double sided disks, both 8" and 5¼" inch drives simultaneously..... **PRICE \$275.00**

■ **LDP88 8088 SINGLE BOARD COMPUTER**
8088 CPU, 1K RAM, 8 K EPROM, Monitor RS232 serial port, 8 vectored interrupts..... **PRICE \$349.00**

■ **LIGHTNING 286 — 80286 CPU BOARD**
Offers 4 times the performance of a 5MHZ 8086 CPU while maintaining software compatibility..... **CALL FOR PRICE**

■ **OCTAPORT 8 PORT SERIAL BOARD**
8 serial ports 0 to 19200 baud operation real time clock interrupt. Ideal for multi-user systems such as MP/M-86.* ... **CALL FOR PRICE**

Our 16 Bit Set: Offers pricing & performance that can't be beat!



Here's your opportunity to move up to 16 bit computing. To make it easier to take advantage of our 16 bit board set, we are offering a special price on the boards you need to get a 16 bit system up and running quickly:

- LIGHTNING ONE model 86/10
- HAZITALL system support board
- LDP72 floppy disk controller
- LDP256K DYNAMIC RAM

Price valid for month of August only.

PRICE \$1695.00

All of LDP boards are fully tested to exacting standards and carry a one year warranty. We specialize in 16-bit products & support the four major operating systems for 16-bit processors: CP/M-86*, MP/M-86, CONCURRENT CP/M-86*, and MS-DOS (PC-DOS).

LDP

Dealer inquiries invited.

LOMAS DATA PRODUCTS, INC. □ 66 Hopkinton Road, Westboro, MA 01581 □ Telephone: (617) 366-6434

*CP/M-86, MP/M-86 and CONCURRENT CP/M-86 are trademarks of Digital Research.
**MS-DOS is trademark of Microsoft.
***Lightning One is trademark of Lomas Data Products, Inc.

Multitasking

Unix, of course, is a timesharing system, which means that more than one person can share the resources of a single computer and its set of storage devices and peripherals. Aside from being a multiuser system, Unix is also multitasking, splitting the available processor time among the various programs run by the users on the system. Even in the smallest Unix environments, where only one person at a time can use the system, this multitasking facility can speed up your work quite a bit.

Suppose you are writing a C program and its documentation. You write the latest changes of your program to disk, request a Unix command line while remaining in the editor, then type the following:

```
$ (cc test2.c 2>errors ; echo check errors) &  
5179  
$
```

This illustrates several features at once. First, note the parentheses around most of the command line.

This treats the enclosed commands as a unit. There are actually two commands on this line, separated by a semicolon, which signifies that they are to be run sequentially. The `cc` command calls for the C program `test2.c` to be compiled, while the number 2 before the output redirection symbol means that only the standard error output (always referred to by the number 2) is to be redirected to a file called `errors`. When this compile is done, the `echo` program is run, which simply sends its arguments to the standard output. Because no redirection is called for, the message will appear at your terminal when the compilation is done. But you don't have to sit there waiting for it because the ampersand (&) at the end of the command line means that both commands (remember the parentheses) will run in the "background" as one. The prompt comes back instantly, preceded by an identification number for the background process. Very simply, this means that your job is running, and you don't have to wait for it to

finish before continuing your work.

Meanwhile, you've gone back to editing your documentation file. When the message check errors appears on your screen, you write your text out to a file (possibly also beginning to print it in background), read in the errors file, note the line numbers of any errors, and fix them by editing `test2.c`. You can, of course, switch between any two or more tasks. It's much easier to sit down and do this than to read about it; it's a very natural way to work, and fast even on small Unix machines.

Every separate program running on Unix is called a *process*. Each process has a unique process identification number (PID). It's this PID that is displayed when you start up a background process, so that if you find the process has gotten stuck or is running too long, you can stop it by typing `kill PID`, where PID is that process identification number. You can also check its progress with the `ps` (process status) command, which will tell you how much processor time each of your programs has used.

Text continued on page 210

COMPUTER DEALERS

THIS AD WRITTEN FOR YOU ...

BYTE INDUSTRIES WANTS TO BE YOUR COMPUTER CONNECTION

Byte Industries is your one STOP shopping place for over 50 lines of microcomputers, terminals, printers and various other computer peripherals and accessories. Byte won't leave you at a STOP waiting for equipment to complete a sale. If you call in your order by 1:00 PST, we'll ship it out THE SAME DAY!

Byte Industries is searching for qualified Computer Dealers in the business of reselling the product we stock. If you're such a Dealer, you may have just found the best wholesale "Computer Connection" available.

BYTE INDUSTRIES IS THE AUTHORIZED COMPUPRO DISTRIBUTOR

I am in the business of reselling computers and related products. I would like a sales representative to contact me and tell me how I can receive my free Wholesale Pricelist and open a Dealer Account.

Name: _____
Store Name: _____
Address: _____
City: _____ State: _____ Zip: _____

Return to: Byte Industries, Inc. (415) 783-8272
21130 Cabot Blvd., Hayward, CA 94545



When critics rate you tops, what do you do for an encore?



*"VISUAL 50 is in a class by itself for visual quality; the character set is unusually clear and sharp."**

*"The VISUAL 50 is the most promising new terminal to come out so far, especially in light of its price."***

*"We consider this terminal to be one of today's best products in price/performance, its incorporation of ergonomically designed features and its broad range of functionality."***

*MICROSYSTEMS—March 1983

**THE ERGONOMICS NEWSLETTER—August 1982

Feature Comparison Chart *

Feature	ADDS 60	VISUAL 50	TeleVideo® 925	Zenith 19	Wyse 100
Style	4	4	4	3	5
Overall Quality	2	5	3	4	3
Keyboard	3	5	2	4	2
Rollover/false keying	5	5	3	4	4
Video Quality	1	5	4	4	3
No. of attributes	5	5	5	2	5
Attribute method	2	5	2	4	2
Suitability for micros	2	5	3	5	3
	24	39	26	30	27
List Price	\$895	695	995	895	995

Meet the VISUAL 55

The VISUAL 50, widely acclaimed as the best performing low cost terminal in the industry, is a tough act to follow. But the new VISUAL 55 extends its predecessor's performance even further by adding 12 user-programmable non-volatile function keys, extended editing features and selectable scrolling regions ("split screen").

Both the VISUAL 50 and VISUAL 55 offer features you expect only from the high priced units. For example, the enclosure is ergonomically designed and can be easily swiveled and tilted for maximum operator comfort. A detached keyboard, smooth scroll, large 7 x 9 dot matrix characters and non-glare screen are only a few of the many human engineering features.

Another distinctive feature of the VISUAL 50 and VISUAL 55 is their

emulation capability. Both terminals are code-for-code compatible with the Hazeltine Espirit,[®] ADDS Viewpoint,[®] Lear Siegler ADM3A and DEC VT52.[®] In addition, the VISUAL 55 offers emulations of the Hazeltine 1500/1510 and VISUAL 200/210. Menu-driven set-up modes in non-volatile memory allow easy selection of terminal parameters.

And you're not limited to mere emulation. Unbiased experts rate the combination of features offered by the VISUAL 50/55 family significantly more attractive than competitive terminals.

Both VISUAL terminals are UL and CSA listed and exceed FCC Class A requirements and U.S. Government standards for X-ray emissions.

Call or write for full details.

VISUAL

See for yourself

Visual Technology Incorporated
540 Main Street, Tewksbury, MA 01876
Telephone (617) 851-5000. Telex 951-539

Circle 414 on inquiry card.

Compute While You the Buffer that

MICROFAZER PUTS YOU BACK TO WORK

Your computer helps you work fast. Unless the printer is running. Then it doesn't help you work at all. It won't let you enter data or process information. It simply won't compute.

That's where Microfazer by Quadram comes in. It's the print buffer that frees your computer. And lets you keep right on working.

THE BUFFER THAT REMEMBERS IT ALL

Microfazer stores data from your computer in its own memory, then sends it to the printer at the proper rate.

You don't have to worry about losing vital information be-

cause of limited buffer space. Because Microfazer starts with 8K of memory and is expandable to 512K—a full half-megabyte. So it can keep pace with your needs. Now, and in the future.

THE ANY COMPUTER. ANY PRINTER BUFFER

Microfazer is perfect for any buffer task. Word Processing. Accounting. Graphics.

EXPANDABLE TO
512K



Available at retail stores worldwide.

Print with Microfazer,TM Remembers It All.

You name it. And it's perfect with any enhancement. Printers. Plotters. Even modems.



You'll find Microfazer in a variety of models and sizes. Some stand alone while others are stackable. There's one that

snaps onto the back of the popular MX Series Epson printers. And another that plugs inside an Epson MX or FX.

There's a Microfazer to interface incompatible devices. And for any data transmission need. Serial or parallel.

QUADRAM REMEMBERS TOO

Whatever your system, Quadram has a buffer to handle it. Including Microfazer's counterpart: Interfazer, for buffering and controlling up to eight computers with one or two printers.

Quadram didn't forget the hardware features either. The Ready LED, manual Reset and Pause/Copy buttons are all part of the

Quadram Quality tradition.

A PRICE YOU'LL GO FOR

You'll be glad to know that you can get Microfazer backed by Quadram Quality at a price that won't stop you from owning one. Parallel to parallel versions start at \$159 (8K). Serial to parallel, parallel to serial and serial to serial versions start at \$199.



**MICROFAZER.
THE PRINT BUFFER
THAT REMEMBERS IT ALL.**



QUADRAM
CORPORATION
An Intelligent Systems Company



4355 International Blvd./Norcross, Ga. 30093
(404) 923-6666/TWX 810-766-4915 (QUADRAM NCRS)

Circle 332 on Inquiry card.

The Shell

Many of the features I've described, while physically implemented in the low-level guts of the system, are controlled by the program you interact with most on Unix—the Shell. The Shell program is run each time you actually log onto the system. Because it is just another program, it can be changed or replaced if you don't like its function.

The Shell is responsible for the user interface to the system. It causes your prompt to be displayed, accepts your commands and causes them to be executed, expands wild-card symbols to provide a complete list of file names to pass to the programs, interprets and processes all the metacharacters (such as &, >, <, |, (,), and ;), and allows you to write fairly complex procedures in its own structured language. Further, it allows you to save a series of personal commands and use them as any other command on Unix.

When sending C files to the printer with pipes, suppose you don't want to type `pr *.c | pr` all the time, especial-

ly after you find out that the default width of a `pr` listing is only 72 columns and you have a 132-column printer. Instead, try writing a simple command line with the `cat` command, taking input from the terminal and directing it into a file:

```
$ cat > lp
(pr -w132 $* | pr) &
^D
$
```

The `^D` (control-d) is taken to be the end of input by many programs on Unix, among them `cat`, `mail`, and the Shell. Now the file `lp` has that single line you typed: it's set up permanently to provide `pr` with 132-column output if necessary, and the entire pipeline is put in the background for even faster response. But what's that `$*`, and how do you execute this as a command?

The explanation is rather involved. Any list of valid commands that can be entered to the Shell may be stored in a file and presented to the Shell for execution. One simple way is by

redirection:

```
$ sh < command_list
... execution of commands ...
$
```

Because you're already running under the Shell, the effect of this is to start up a *new* Shell as a process, which then executes your commands, ends, and returns to you. In fact, this is the way all commands are executed from the Shell; the currently running Shell makes a fork system call, effectively reproducing itself, then waiting for the "child" Shell to finish. You can also use the `chmod` command described before to make the file of commands executable; after that, only the name of the file needs to be typed. When the Shell reads a command file that has been thus marked executable, it will execute each command in the file. So you would type:

```
$ chmod +x command_list
$ command_list
... execution of commands ...
$
```

EXPORTING SERVICES

Overseas dealers and distributors. You need the lowest prices, prompt delivery, exclusive territories and professional services. We've provided these for three years. We've access to over 500 U.S. hardware and software manufacturers. Telex us NOW for more information or a quotation.

American Buying and Exporting Services

1635 School St.
Moraga, CA 94556
(415) 376-7600
Telex: 470851

DECADES OF SERVICE

Washington Computer Services

97 Spring St., New York, NY 10012 an affiliate of ((WASHINGTON ELECTRIC COMPANY)) est. 1912

TO ORDER: Call our toll-free number: (800) 221-5416. In N.Y. State and for technical information: (212) 226-2121. Hours: 9 AM-5:30 PM (EST) Monday-Friday TELEX: 12-5606 CABLE: WASHCOMP NYK

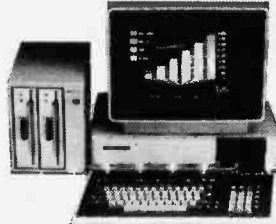

NEC PC-8800

The Professional's Workstation
We feel that this uniquely versatile graphics workstation offers a most cost effective microcomputer solution.

- INCLUDES:**
- CP/M
 - MBASIC-80,86
 - WORDSTAR
 - MULTIPLAN
 - HIGH RES. (640 x 400) CAD/CAM GRAPHICS
 - MONOCHROME & RGB COLOR
 - 5 1/4" & 8" DISK DRIVES
- OPTIONAL:**
- 8 Mhz 8086, 16 BIT
 - HARD DISK DRIVE
 - SPEECH SYNTH. & RECOG.
 - LIGHT PEN

Please call for prices and a demonstration.
NEC on NYS OGS Contract #P-07220

PLEASE! Do not confuse us with mail order dealers. We are a full service distributor serving the data processing & installation needs of business & industry from micros to mainframes. System houses, educational institutions & governmental agencies given special consideration. Leasing available. N.Y. State agencies, municipalities, and schools—call us for information on our O.G.S. term contracts on hardware & software.

Please call to make an appointment for demonstration of this extraordinary computer at our showroom. Prices subject to change without notice; call for latest prices. Prices include 3% cash discount. N.Y. residents add sales tax. CP/M® is a trademark of Digital Research. All sales subject to our standard sale conditions (available on request). Above prices do not include customization or installation.

"BUBBLES HELP MPC PROTECT APPLES FROM BRUISES."

—Daniel R. Obed, CEO
MPC Peripherals Corp.
San Diego, California



And dust. And dirt. And heat. And vibration. All the elements that can cause a disk drive to turn sour.

But thanks to a fresh idea from MPC Peripherals, Apples® can now run in the most demanding environments.

With BUBDISK™, a MPC memory module more rugged than a disk drive. More versatile than a RAM card.

A board that uses an Intel 7110 bubble.

The 7110 gives BUBDISK a full megabit of solid-state memory. As well as three times the data access speed of a floppy. Over 1000 times the data integrity of

tapes or disks. Plus a 10-year MTBF. Assuring that BUBDISK will smoothly work in environments where other types of mass storage have trouble operating at all.

Because the Intel 7110 bubble is non-volatile, MPC's BUBDISK retains its memory through power failures and power surges. Or when you simply turn the Apple off.

And BUBDISK makes Apples portable as well as durable, because it doesn't require battery back-up. Allowing Apples to operate just about anywhere, for any application. From truck stops to oil rigs. Grain elevators to highway maintenance.

So remember. If reliable memory is going to make or break your design, protect it with Intel bubbles.

Call Intel, toll-free.

(800) 538-1876. In California, (800)

672-1833. Or write

Intel Corporation, Lit.

Dept. #Y-2, 3065 Bowers Avenue, Santa Clara, California, 95051.

intel® delivers solutions

The MPC BUBDISK
Bubble Memory Module.
Featuring an Intel 7110 bubble.

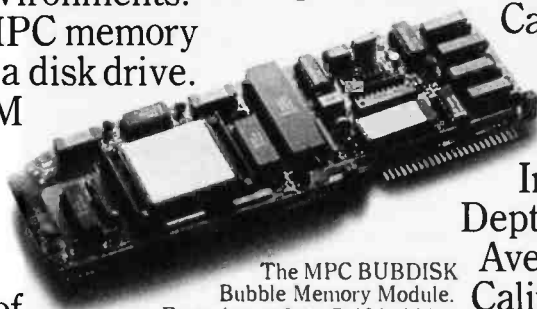

Apple is a registered trademark of Apple Computer Inc. BUBDISK is a trademark of MPC Peripherals Corp.

A Survey of Unix and C Resources

by Walter Zintz

Unix and C users have many sources they can turn to for general help and moral support. Much of this help is free or available at minimal cost—in most cases, you'll find that the cult-like history of Unix has created an atmosphere of camaraderie rather than exclusivity.

At least three Unix user groups are active in the United States. The oldest, Usenix (POB 7, El Cerrito, CA 94530-0007, (415) 528-8649) is oriented toward university users; it offers a newsletter, conferences, and software distributions for source-license holders. Another organization, /usr/group (POB 8570, Stanford, CA 94035-0221) was founded by system vendors, although membership is open to users. The group publishes a newsletter and an annual Unix product directory, has committees actively working on Unix standardization and licensing, holds conferences, and offers sponsorship to local user groups. Uni-Ops (POB 5182, Walnut Creek, CA 94596-1182, (415) 945-0448) began with a nucleus of newer Unix end users who wanted to share information. Uni-Ops holds conferences, tutorials and local meetings, coproduces a newsletter and an online software index/exchange, sponsors a Berkeley Unix SIG (special interest group), and maintains a mailing list of Unix and C users. The C Users Group (POB 287, Yates Center, KS 66783, (316) 625-3554) was originally for users of a C language subset that runs under CP/M, but it now supports the general C community. The group has a newsletter and distributes software. Unix user associations are also active in Canada, Europe, Australia, and Japan.

Usenix holds the largest conferences, which are a common meeting ground for everyone involved in Unix, although the papers presented are often a bit esoteric; /usr/group conferences offer the best exposure to available products. Uni-Ops slants its conferences toward newcomers to Unix who want to know how to get started.

Other sources for newsletters include Southwater Corporation (30

Mowry St., Mount Carmel, CT 06518, (203) 288-0283), which publishes *World Unix & C*, a nontechnical newsletter in a newspaper format. Infopro Systems (POB 33, East Hanover, NJ 07936, (201) 625-2925) publishes *Unique*, a mixture of technical and product information. Urban Software Corporation (330 West 42nd St., New York, NY 10036, (212) 736-4030) publishes a somewhat eclectic newsletter called the *Urban Software Newsletter*.

Local user meetings are starting to take hold. Established, regular meetings are held in the Washington, DC, and Silicon Valley areas. For meeting schedules and agendas in either of those areas, contact Gary Donnelly (RLG Corp., Suite 508, 1760 Reston Ave., Reston, VA 22090) and Uni-Ops, respectively. Regular meetings are firming up in the Boston area, and several metropolitan areas in the Sunbelt are trying to get meetings started.

On Line

Electronic meetings using Unix's uucp utility are popular, too. By far the largest network is Usenet, in which systems poll each other over phone lines. Usenet allows intersystem mail at minimal cost, and Netnews as a bonus. To have your system formally admitted to Usenet, contact Stephen Daniel (Dept. of Computer Science, Room 201, North Building, Duke University, Durham, NC 27706, (919) 684-3048). Many new Usenet sites simply find a nearby installation that is already on Usenet and arrange to poll or be polled. A system that joins the net this way is not known to the Usenet software; it appears to Usenet as an individual user on the parent installation. I've seen Usenet addresses with as many as eight intermediate systems in them, but this delays messages and runs up phone bills to boot. Also, users on "hung-on" (polling or polled) systems do not have direct access to Netnews.

If you find that the polling equipment needed to access Usenet is beyond your budget, consider The C Line, a fledgling free service out of New Jersey. It's a message drop, bulletin board, and free software exchange for C language users. A new user need merely dial up the central

computer, log on to the system, and begin browsing around. The C Line runs on a CP/M system, but it has two packages of Unix-like utilities to help Unix users feel at home. To access the C line, call (201) 625-1797 (with your modem set anywhere from 110 to 710 bits per second), hit a few carriage returns, then follow the system's prompts. The C Line is available at all hours except from 9:00 A.M. to 8:00 P.M. on weekdays; that's when the system's owners are using it for their own work.

Books

The serious Unix user also needs detailed information in printed form. Bell Laboratories is a good source to start with. It offers a flock of manuals on various aspects of System V and smaller but still substantial manual sets for earlier versions of Unix. These are thorough and rigorous (but not easy to read), and they're now available to anyone, with or without a Unix license. Bell Labs also has reprinted the *Bell System Technical Journal* special issue on Unix (July-August 1978), a wellspring on the philosophy and history of Unix. In conjunction with Holt, Rinehart and Winston, Bell Labs has brought out two volumes of the *UNIX Programmer's Manual* (New York: Holt, Rinehart and Winston, 1983).

The runaway best-seller among books on Unix, and deservedly so, is *A User Guide to the UNIX System* by Rebecca Thomas and Jean Yates (Berkeley, CA: Osborne/McGraw-Hill, 1982). Its technical chapters cover the most used Unix commands in clear style suited even to computing beginners, the resources sections are still useful as an elementary guide to software and services available, and the appendix has the complete official description of version 7 Unix as released by Bell Labs. Now, though, several newly published books are making strong bids for space on your bookshelf. *Introducing the UNIX System* by Henry McGilton and Rachel Morgan (New York: McGraw-Hill, 1983) has an ocean of information on what to do at a terminal or console. *The UNIX System* by Steve Bourne (Reading, MA: Addison-Wesley, 1983) is good on theory as well as practice,

and strong on the Bourne shell. *Unix Primer Plus* by Mitchell Waite, Donald Martin, and Steve Prata (Indianapolis, IN: Howard W. Sams and Co., 1983) will emphasize Berkeley Unix and be strong on logically organized reference tables and illustrative graphics.

There are worthwhile new books on C programming, too. Beginners, though probably not raw beginners, should consult *Learning to Program in C* by Thomas Plum (Cardiff, NJ: Plum Hall, 1983), which is rather complete for an introductory book and is not Unix-dependent. Plum also wrote *C Programming Standards and Guidelines* (Cardiff, NJ: Plum Hall, 1982). *The C Primer* by Les Hancock and Morris Krieger (New York: McGraw-Hill, 1982) is a good introduction to the language. People with some C experience can have fun while advancing their skills with *The C Puzzle Book* by Alan R. Feuer (Englewood Cliffs, NJ: Prentice-Hall, 1983), which is exactly what its name suggests. We mustn't overlook the standard reference work *The C Programming Language* by Brian Kernighan and Dennis Ritchie (Englewood Cliffs, NJ: Prentice-Hall, 1978) and *C Notes* by C. T. Zahn (New York: Yourdon Press, 1979).

With Unix's blooming popularity of late, your computer store or technical book shop may have the manuals and books you want. If not, three mail-order book services specialize in Unix and C. All three have lists of the books and manuals they offer and their prices. Cucumber Bookshop Inc., (5611 Kraft Dr., Rockville, MD 20852, (301) 881-2722) is the oldest. The Unix Bookstore (47 Potomac Street, San Francisco, CA 94117, (415) 621-6415) is run by a veteran Unix and C instructor. Southwater Corp. (30 Mowry St., Mount Carmel, CT 06518, (203) 288-0283) also carries general programming books.

Courses

A flood of tutorial sources has emerged in the last year or so. Some organizations offer courses at your site, others schedule classes in major cities around the country, still others hold all their training at their own offices. Many have hands-on training, with one to three students per terminal, others teach through lectures and

audiovisual materials.

Of the many tutorial firms these days, I can list only the most active ones. California firms include the Center for Advanced Professional Education Inc. (11928 North Earlham, Orange, CA 92669, (714) 633-9280), International Technical Seminars (47 Potomac St., San Francisco, CA 94117, (415) 621-6415), and The Wollongong Group (1135A San Antonio Rd., Palo Alto, CA 94303, (415) 962-9224).

In the Midwest, contact Uniq Computer Corp. (28 South Water St., Batavia, IL 60510, (312) 879-1566), the Computer Technology Group, (Telemedia Inc., 310 South Michigan Ave., Chicago IL 60604, (312) 987-4000), Unir Corp. (Suite 106, 5987 East 71st St., Indianapolis, IN 46220, (317) 842-7014), and, in Canada, Human Computing Resources Corp. (Suite 401, 10 Saint Mary St., Toronto, Ontario M4Y 1P9, Canada, (416) 922-1937).

On the East Coast, you can try RLG Corp. (Suite 508, 1760 Reston Ave., Reston, VA 22090, (703) 471-6860), Plum Hall Inc. (1 Spruce Ave., Cardiff, NJ 08232, (609) 927-3770), Structured Methods Inc. (7 West 18th St., New York, NY 10011, (212) 741-7720), DJR Associates Inc. (303 South Broadway, Tarrytown, NY 10591, (914) 631-6766), Training Services Group (Bunker Ramo Information Systems, Trumbull Industrial Park, Trumbull, CT 06609, (203) 386-2600), and the Institute for Advanced Professional Studies (55 Wheeler St., Cambridge, MA 02138, (617) 497-2075).

In the computer age it's practical to teach Unix and C without face-to-face meetings, and two organizations have software to do just that. User Training Corp. (POB 970, Soquel, CA 95073), (408) 354-6433 uses audio cassettes and a black box the firm manufactures to let you listen through earphones to an instructor's explanations while you watch an example displayed on your terminal screen. Uni-Ops (mentioned earlier) offers computer-managed-instruction interactive tutorials that can be run on any Unix system.

Walter Zintz is affiliated with Uni-Ops (POB 5182, Walnut Creek, CA 94596).

The dollar sign in \$* is the Shell's notation for a parameter whose value you may change. If a digit followed the dollar sign, then the argument corresponding to that number is substituted (\$0 would represent the command file name itself). The \$* simply means to expand all arguments following the command file name and substitute them for the \$*.

In the case of our new command `lp` above, now you need only type `lp *.c` to have all your C source files printed and nicely paged in the background. Even better than this is the programming language built into the Shell. Here's a quick example:

```
rm /tmp/cprinter
for i in *.c
do
  cc $i 2>$i.err
  cb $i | pr >> /tmp/cprinter
  pr $i.err >> /tmp/cprinter
done
lpr /tmp/cprinter
rm /tmp/cprinter
```

First, any temporary file with the given name (in this case, `/tmp/cprinter`) is removed. Then the program loops through each occurrence of a C source file by replacing the \$i with the proper name, compiles it (sending the error output to a similarly named file; e.g., `test.c` would have an error file; `test.c.err`), runs the C beautifier (`cb`) program (which indents structures and loops), sends the result through `pr` to be paged and dated, and appends this to the temporary file. Then the error file is paged and appended. When all C files have been through this procedure, the temporary file is printed and removed.

Why go through all this? If the C compiler sees a list of files, it assumes they are all to be compiled and loaded together, and this is not always the case. And if all the output was not directed to the temporary file, we might have had 45 or so separate printouts from all the source and error files. This type of short program doesn't even have to be saved in a file; it could be typed directly into the Shell and interpreted on the spot. And much more elaborate programs

ANNOUNCING UNIX™ and MS-DOS SOFTWARE

UNIX III FOR APPLE LISA:

Full Bell Labs System III implementation with UNISOFT enhancements. \$495 - \$1495

EMACS:

Reclaimed Gosling version, for UNIX and VMS. Full screen, multi-window, extensible editing system with built-in COMPILED MLISP.

From \$395

LEX:

Finest WORD PROCESSOR available under UNIX or MS-DOS (and all DEC operating systems.) Full screen editing and interactive formatting. Built-in spelling, calculator, and mass mailing.

From \$500

THE MENU SYSTEM:

Build menus INTERACTIVELY for any application. Multiple windows. System commands can be issued at any time.

From \$495

PHACT ISAM:

Multikey isam file system, handles VARIABLE length records. The routines can be included in any C program. Runs on MS-DOS tool

From \$250

RDB:

More than 40 relational data base TOOLS for UNIX.

From \$495

MIMIX:

CP/M EMULATOR. Migrate your programs to UNIX. Runs CP/M object code. Hardware assist optionally available.

From \$495

UNICALC:

SPREADSHEET, with mathematical, trig, conditional functions. \$175

AND FOR MS-DOS

C Compiler \$395

Software Tools \$200

PHACT ISAM \$250

YOUR UNIX SOFTWARE SOURCE

UNIPRESS SOFTWARE, INC.

1164 Raritan Avenue
Highland Park, NJ 08904

Orders: 800-222-0550

Technical: 201-985-8000

Visa and Master Charge Accepted

UNIX is a trademark of Bell Laboratories

are possible.

Development Tools and Languages

The most important aspect of software development is whether the tools needed for development are available. Unix not only has a full set of interpreters and compilers for various languages, but also includes programs that can be invaluable in creating your own language processors.

A typical Unix system will come with a C compiler (cc), assembler (as), syntax and portability checker (lint), a loader (ld) for the processor the system runs on, an interpreter for a BASIC-like language (bs), and the C beautifier (cb) mentioned before. A set of programs, together called SCCS (Source Code Control System), allows all changes made to source files to be stored, so that a previous level of revision can be reconstructed at any time—a lifesaver for people who tend to lose track of their latest changes. A sophisticated file comparator (diff) shows the exact differences between two text files and, optionally, can tell the text editing program how to convert one to the other. A full FORTRAN 77 compiler (f77) and a structured Ratfor-to-FORTRAN filter (ratfor) are included, as are numerous programs used to plot graphical output on a variety of devices. You also get a general-purpose macro processor (M4), a SNOBOL interpreter (sno), a program that will let you generate programs to perform lexical analysis (lex), a string-processing language (awk), and a compiler generator (yacc), not to mention the typesetting program (troff) and its word-processing companion (nroff).

You can expect all of the above with standard Unix. Also available are cross-compilers for almost every type of microprocessor available, COBOL compilers, FORTH interpreters, various versions of Pascal and Ada, translators from several languages to C, and LISP. Each month I receive dozens of press releases about new software products for Unix systems, such as full-screen editors, word-processing packages, applications pro-

grams, and even a few CP/M emulators. Almost everything you could ever need to develop and use software on Unix is on the market; you just have to find it.

Communications

Unix was invented at Bell Laboratories, so it's not surprising that the system makes it easy for you to use the telephone network for computer-to-computer communications. Interpersonal communication is natural and uncomplicated on Unix. The command most people first discover is the impromptu write facility, which lets you exchange messages with another person currently logged into the system. Each of you can write a message, then wait for the other's answer; in this way, a slow conversation can take place.

If the party you wish to reach is not logged on, the write command will tell you so. In this case you can send electronic mail with the mail command and the recipient will be notified of its existence when he or she next logs on. Mail is postmarked with the date and time sent and who sent it. You can type outgoing mail directly from the terminal or use an editor and text formatter to make it a bit fancier. Mail can even be forwarded to other people, and you can send the same item to several people at once. The mail facility proves to be quite useful in an organizational setting because people can log on at any time and send a message they know will be received eventually. Mail to yourself is equally useful as a reminder, and all incoming mail can be saved for future use.

Mail can also be sent to remote systems semi-automatically. If your Unix system is capable of dialing the phone by an automatic calling unit or intelligent modem, it may already have been set up to use the uucp facility to access other Unix systems. The name uucp is an acronym for "Unix-to-Unix copy"; essentially it uses an error-checking protocol to allow files to be transferred between machines. The important thing about uucp is that, once set up, it is easy to operate. You need only specify the publicly known name of the reci-

IS THIS LEVEL OF RELIABILITY REALLY NECESSARY?

ACCUTRACK



If you've ever lost data due to a faulty disk, you know how important reliability can be.

That's why Accutrack disks are critically certified at 2-3 times the error threshold of your system. Why they're precision fabricated for higher signal quality, longer life and less head wear. And why we take such extra steps as testing single-density mini disks at double-density levels. So you don't have to worry about the reliability of your media.

Accutrack disks. OEMs have specified them for years. You can trust them for your data. Call toll-free (800) 225-8715 for your nearest dealer.



ACCUTRACK
Dennison KYBE Corporation

82 Calvary Street, Waltham, Mass. 02254
Tel. (617) 899-0012; Telex 94-0179
Outside Mass. call toll free (800) 225-8715
Offices & representatives worldwide

Circle 306 on Inquiry card.

Dealers: Give your customers a choice—Accutrack's OEM performance as well as your heavily advertised brand. We have the industry's only complete line of disks, cassettes and mag cards, including virtually all special formats. If you want a quality line, small minimums, the ability to mix and match, private labeling, fast delivery and great price, call today. Find out how responsive a media supplier can be.

patient's machine and his or her user name, as in `infoprol:dave` or `decvax:laps`. Then instead of sending to Ann by typing `mail ann`, you can just type `mail harpol:ann` if harpo is the name of Ann's machine, and this will automatically send the remote mail via uucp. If your computer is part of the informal uucp-net, you can specify a series of machine names through which the messages will be passed until the final destination is reached, as in `decvax!harpo!floyd!infoprol:dave`. The advantage of this is that each machine in the chain only has to make a local or short-distance call, saving ultimately in telephone charges. Other similar networks exist, and in some the message will be automatically passed by the shortest available route. Regular program, text, and data files can also be sent and received using uucp, which is set up to dial in the middle of the night when phone rates are cheapest.

Transfer of data can also be initiated manually with the `cu` (call Unix) command. This lets you simply specify a phone number to be dialed, after which you can log onto the other machine, run programs, and send files back and forth. The combination of all these facilities allows Unix users all over the country to interact almost as if they were on one large machine. In addition, a few electronic news services enable people to conduct ongoing discussions, announce products, and spread rumors.

Unix Compared to Other Operating Systems

It's hard for some diehard buffs to remember that Unix isn't the only operating system around and that it still lacks a few important features.

Most inconvenient for business users is the lack of either file or record locking at the user program level. These facilities would allow several users to access the same database at once without fear that information would be inaccurate, as it can be when several different people write the same record simultaneously. While several commercially available database systems (such as MDBS III, Informix, and Mistress) handle this

problem internally, Unix software designers are hampered without a standard set of system calls to depend on.

Real-time facilities that could guarantee a maximum known response time for selected programs would benefit not only laboratory researchers (for whom such facilities are absolutely essential) but also would allow acceptance of Unix in other markets where speed is necessary. A simple order-entry program can be brought to its knees by an `nroff` program run at the wrong moment when the system as a whole is not carefully tuned and monitored.

Each time a person logs onto Unix a new process is created. When attempting to put large numbers of users on a single computer system simultaneously, Unix system administrators find that the large number of processes thus created is itself a drain on the system. Unix spends a good deal of time in switching context between processes; so the net result of too many processes is a system that spends most of its time doing no productive work. This prevents Unix from replacing other operating systems in traditional data centers where one mainframe computer might serve hundreds of terminals. While it is likely that networks of small Unix-based workstations will tend to make such traditional configurations obsolete, certain applications may be restricted from using Unix for this reason.

Virtual memory is not yet supported, even on machine configurations where this is possible. While this feature and record/file locking are expected to be added in future Bell releases of Unix, it has so far remained the province of the University of California at Berkeley to support virtual memory with its release of Unix, known as 4.2 BSD. However, this version is not widely available on the commercial market.

It was once commonly accepted that a Unix guru had to be on call at all times to reconstruct the file system after the almost inevitable system failure. This is no longer true; utilities exist on Unix to fix the file system automatically after a crash, and

crashes themselves are less frequent on newer releases due to improved ordering of disk writes and other factors. Nevertheless, while on many competing commercial systems all running programs will resume without error after a crash, that sort of improvement is not expected soon on Unix.

As previously mentioned, security of individual files tends to be left to the users themselves or the system administrator. While an almost foolproof data-encryption algorithm used on Unix for passwords may be invoked by users to encode any file they wish, several known methods can be used to compromise both user passwords and the super-user password. The result of this compromise could be destruction of important data files and the possible dilution of the encryption algorithm. Therefore, we advise would-be keepers of sensitive information to administer Unix with care.

System resources, in terms of exclusive use of physical devices and processor and memory facilities, are not adequately protected. This means that a naive user's first C program could crash the system. Also, if a program needs a tape drive and it is not available, the program will simply fail rather than wait for the tape.

However, these failings must be weighed against some more facts: First, Unix uses much less memory than other large operating systems, needing 64K to 160K bytes of main memory for the executable kernel. Large systems may require a megabyte of memory to run, or even more. Of greater importance is the size of the source code. Written in a high-level language, Unix is manageable by one person, while assembly-language operating systems tend to need teams of programmers just to install the fixes issued each month by the supplier.

The one-time cost of Unix, to an end user, is measured in the hundreds of dollars; compare this to the multiple thousands required *per month* to license and maintain a mainframe operating system. In fact, the cost of Unix in binary form approaches that of a single-user CP/M

THE NEW CANON[®] MICROCOMPUTER.

Its graphic system makes brilliant color more affordable.



Now everyone can have the advantage of a full-color graphics system at a very affordable price.

The Canon AS-100 microcomputer gives you a choice of 27 high resolution colors. Plus, its quiet color ink jet printer generates clean, crisp, impressive copies.

And it isn't just the AS-100's vivid color that dazzles.

It has a powerful, fast 16 bit microprocessor with standard 128K RAM.

A choice of storage capacity that includes 5¼ mini or 8 inch floppy disks, with hard disk drive also available.

A software system that uses either CP/M-86* or MS-DOS†, and if you prefer, a monochrome green or black and white display unit.

All of which make it the perfect tool for business and professional needs.

The new Canon AS-100. It's so smart, it makes life simple.

*CP/M-86 is a trademark of Digital Research. †MS-DOS is a trademark of MICRO SOFT. © 1983 Canon U.S.A., Inc.

Canon U.S.A., Inc.
Systems Division
One Canon Plaza, Lake Success, NY 11042

Please send me more information about the Canon AS-100 Microcomputer.

Name _____ (Please print)

Title _____

Company _____

Address _____

City _____ (State) (Zip)

Phone (____) _____

Canon
So smart, it makes life simple.

64K STATIC RAM MEMORY

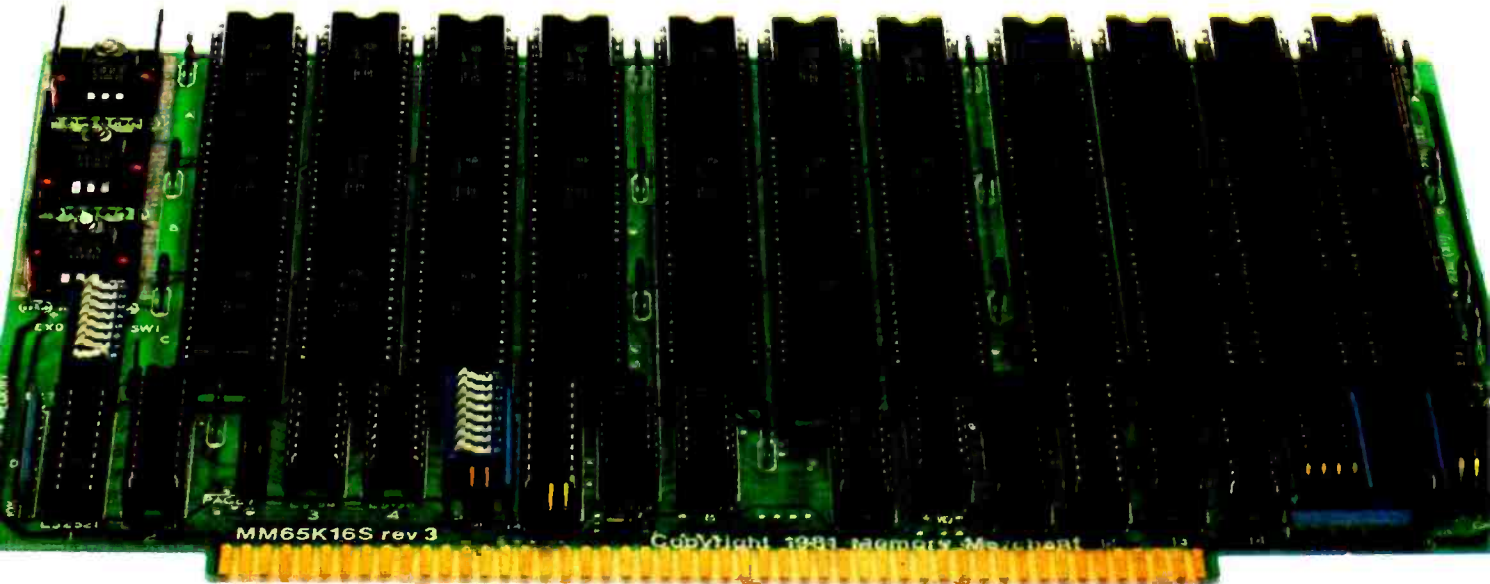

S-100 STATIC MEMORY BREAKTHROUGH

Finally, you can buy state-of-the-art S-100/IEEE 696 static memory for your computer at an unprecedented savings.

Memory Merchant's memory boards provide the advanced features, quality and reliability you need for the kind of operational performance demanded by new high-speed processors.

Completely Assembled.

These memory boards are not kits, nor skeletons — but top-quality, high-performance memories that are shipped to you completely assembled, burned-in, socketed, tested and insured with one of the industry's best warranties.

Superior Design & Quality.

Memory Merchant's boards are created by a designer, well known for his proven ability in advanced, cost-efficient memory design. Innovative circuitry provides you with highly desired features and incredible versatility.

Only first-quality components are used throughout, and each board is rigorously tested to assure perfect and dependable performance.

No Risk Trial.

We are so convinced that you will be absolutely delighted with our boards that we extend a no-risk trial offer. After purchasing one of our boards, you may return it (intact) for any reason within 15 days after shipment and we will refund the purchase price (less shipping).

NEW S-100 PRODUCTS COMING SOON:

- * DUAL 8/16 BIT CPU BOARD
- * 128K 8/16 BIT STATIC RAM
- * 256K 8/16 BIT DYNAMIC RAM

\$629.

48K PARTIALLY POPULATED \$519.
32K PARTIALLY POPULATED \$409.

64K RAM, MODEL MM65K16S

- 64K x 8-bit
- Speed in excess of 6 MHz
- Uses 150ns 16K (2K x 8) static RAMS
- Ultra-low power (435 Ma. max. — loaded with 64K)
- Bank Select **and** Extended Addressing
- A 2K window which can be placed anywhere in the 64K memory map
- Four independently addressable 16K blocks organized as:
 - Two independent 32K banks **or**
 - One 64K Extended Address Page **or**
 - One 48K and one 16K bank for use in MP/M¹ (option)
- Each 32K bank responds independently to phantom
- 2716 (5V) EPROMS may replace any or all of the RAM
- Field-proven operation in CROMEMCO CROMIX* and CDOS*.
- Compatible with latest IEEE 696 systems such as Northstar, CompuPro, Morrow, IMS, IMSAI front panel, Altair and many others.

OEM and DEALER inquiries invited.

MM Memory™
Merchant

14666 Doolittle Drive
San Leandro, CA 94577
(415) 483-1008

Circle 255 on inquiry card.
www.americanradiohistory.com

FULL TWO-YEAR WARRANTY.

The reliability of our boards, through quality-controlled production and proven performance, has enabled us to extend our warranty to a full two years. That's standard with us, not an option. This includes a 6-month exchange program for defective units.

Shipped direct from stock.

All Memory Merchant's boards are shipped direct from stock, normally within 48 hours of receipt of your order. Call us at (415) 483-1008 and we may be able to ship the same day.

16K RAM, Model MM16K14

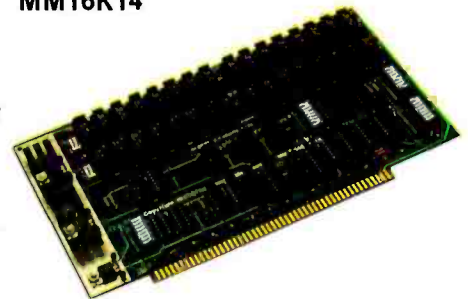

16K STATIC RAM \$169.

16K x 8 Bit
Bank Select & Extended Addressing
Four independently addressable 4K blocks
One 4K segment equipped with 1K windows
Uses field-proven 2114 (1K x 4) RAMS
Low Power (less than 1.2 Amps)
Runs on any S-100 8080, 4 MHz Z-80 or 5 MHz 8085 system.

Prices, terms, specifications subject to change without notice.

*Cromix and CDOS are trademarks of CROMEMCO.
* MP/M is a trademark of Digital Research

license!

Unix is portable, requiring from 1 to 12 months for a experienced systems programmer to move it to a different hardware configuration.

Comparing Unix to even smaller systems like CP/M is pointless because no single-user, single-tasking system is comparable to Unix on a features basis. However, important market considerations abound, which will be taken up in part 3 of this series.

Moving On

The features I've described explain why an expanding segment of the computer industry feels that Unix has reached its goal of being a pleasant environment in which to write and use programs.

Next month, I'll discuss what applications programs are available under Unix and some specific ways you can create a personalized environment on Unix. The last article of this three-part series will address Unix implementations on several different microprocessors and look at Unix in the marketplace of the future—where AT&T is likely to go with it, how it will stack up against other operating systems, and what your first Unix-based computer is likely to be. ■

References

1. Gilbreath, Jim. "A High-Level Language Benchmark," BYTE, September 1981, p. 180.
2. Greenberg, Robert B. "The UNIX Operating System and the XENIX Standard Operating Environment." BYTE, June 1981, p. 248.
3. Hancock, Les and Morris Krieger. *The C Primer*. New York: McGraw-Hill, 1982.
4. McGilton, H. and R. Morgan. *Introducing the UNIX System*. New York: McGraw-Hill, 1983.
5. Meyer, E. C. "MULTICS Alumnus Sets the Record Straight on UNIX." *Intoworld*, May 10, 1982, p. 30.
6. Ritchie, D. M. "UNIX Time-Sharing System: A Retrospective." *The Bell System Technical Journal*, July-August 1978, p. 1905.
7. Rosenblatt, A. "The 1982 Award for Achievement." *Electronics*, October 20, 1982, p. 108.

David Fiedler (Infopro Systems, POB 33, East Hanover, NJ 07936) is the editor of the monthly newsletter *Unique: Your Independent UNIX and C Advisor and the magazine UNIX Review*. He is also an analyst for the Perchwell Corporation, a consulting firm assisting management of companies using Unix.



WE WON THE PRICE WAR

In every battle, we came up the victors. Not only in price, but in service and support as well.

Call to order: **1-800-257-5217**
(in NJ 609-424-4700)

We carry:

TRISTAR

Intertec Data Systems
Corvus Concept
Corvus Hard Disk
C. Itoh Printers
Victor 9000

TriStar Data Systems
2 Keystone Avenue
Cherry Hill, NJ 08003
609-424-4700
215-629-1289

LET GINA WORK FOR YOU

GINA Sells Systems
GINA is an interactive point-of-purchase sales aide which acquaints customers with computer basics and helps define their needs. GINA's friendly format gives your customers confidence in using a computer.

GINA Saves Time And Money
While GINA entertains and informs your customers, your staff is free to close sales. Since GINA pre-qualifies customers, less time is spent on each sale.

GINA Gives You a Choice
GINA recommends generic systems. If you choose GINA+, you can promote specific brand-name systems.

For more information about how GINA can help increase your profits and productivity, call **(415) 697-3861**





**SYSTEM
VISION
CORPORATION**

199 California Dr.
Suite 207
Millbrae, CA 94030

LOWEST SOFTWARE

We hereby certify that your purchase from Discount Software represents the lowest price sold anywhere. If you find a lower price on what you purchased within 30 days, send the ad and we'll refund the difference.

	Discount Price
CP/M	
ARTIFICIAL INTELLIGENCE	
Medical (PAS-3)	\$849
Dental (PAS-3)	\$849
ASHTON-TATE	
\$4?? dBASE II...	call for price
dBASE User's Guide	\$29
Friday	\$265
Financial Planner	\$595
Bottom Line Strategist	\$349
ASYST DESIGN/FRONTIER	
Prof Time Accounting	\$549
General Subroutine	\$269
Application Utilities	\$439
DIGITAL RESEARCH	
CP/M 2.2	
Intel MDS	\$135
\$149 Northstar	
\$159 TRS-80 Model II (P&T)	
Micropolis	\$175
\$98 CBasic-2	
Display Manager	\$319
Access Manager	\$239
\$449 PL/1-80	
BT-80	\$179
MAC	\$85
RMAC	\$179
Sid	\$65
\$90 Z-Sid	
DeSpool	\$49
CB-80	\$459
Link-80	\$90
FOX & GELLER	
Quickscreen	\$135
Quickcode	\$265
\$65 Dutil	
D Graph	\$265
MICRO DATA BASE SYSTEMS	
Knowledge Man	\$429
HDBS	\$595
MDBS	\$1099
DRS or QRS or RTL	\$319
MDBS PKG	\$1999
MICROPRO	
\$279 WordStar	
\$179 Mail Merge	

WordStar/Mailmerge	\$399
WS/MM/SpellStar	\$549
\$199 SpellStar	
DataStar	\$249
InfoStar	\$349
ReportStar	\$254
Wordmaster	\$119
Supersort I	\$199
Calc Star	\$129
MICROSOFT	
\$249 Basic-80	
\$329 Basic Compiler	
\$349 Fortran-80	
\$549 Cobol-80	
Multiplan	\$219
M-Sort	\$175
\$159 Macro-80	
MuSimp/MuMath	\$224
MuLisp-80	\$174
ORGANIC SOFTWARE	
Textwriter III	\$111
Datebook II	\$269
Milestone	\$269
OSBORNE (McGraw/Hill)	
G/L, or AR & AP, or PAY	\$59
All 3	\$129
All 3 + CBASIC-2	\$199
Enhanced Osborne	\$299
PEACHTREE	
G/1, A/R, A/P, PAY, INV (each)	\$399
P8 Version	Add \$234
Peachcalc	\$249
Peachpack (G/L, A/R, A/P)	\$349
STAR COMPUTER SYSTEMS	
G/L, A/R, A/P, Pay (each)	\$349
All 4	\$1129
Legal or Property Mgt.	\$849
STRUCTURED SYSTEMS	
Business Packages (call)	
SORCIM	
\$179 SuperCalc I	
SuperCalc II	\$265
Act	\$157
SUPERSOFT	
Ada	\$270
Diagnostic II	\$89
Disk Doctor	\$89
Forth (8080 or z80)	\$149
Fortran	\$319
Ratfor	\$79
C Compiler	\$225
Scratch Pad	\$266
StatsGraph	\$174

Analiza II	\$45
Disk Edit	\$89
Term II	\$179
Utilities I or II	\$54
SOFTWARE DIMENSIONS/ACCOUNTING PLUS	
1 Module	\$399
4 Modules	\$1499
All 8	\$2799
UNICORN	
Mince or Scribble (each)	\$149
Both	\$249
The Final Word	\$270
WHITESMITHS	
"C" Compiler	\$600
Pascal (incl "C")	\$850
"PASCAL"	
Pascal/MT+ Pkg	\$429
Compiler	\$315
SP Prog	\$175
Pascal Z	\$349
Pascal/UCSD 4.0	\$349
DATA BASE	
dBASE II	Call 4??
Friday!	\$265
FMS-80	\$799
FMS-80-1	\$399
Condor I & III	Call
Selector	\$689
Superfile	\$159
"WORD PROCESSING"	
Perfect Writer	\$389
WordSearch	\$114
SpellGuard	\$139
Peachtext	\$289
Spell Binder	\$349
Select	\$495
The Word	\$65
\$145 The Word Plus	
Palantier-1 (WP)	\$385
"COMMUNICATIONS"	
Ascom	\$149
BSTAM or BSTMS	\$149
\$139 Crosstalk	
\$89 Move-it	
"OTHER GOODIES"	
Micro Plan	\$419
Plan 80	\$264
Target PlannerCalc	\$79
Target Financial Modeling	\$299
Target Task	\$299
MicroStat	\$224
Vedit	\$130
MiniModel	\$449
StatPak	\$449
Micro B+	\$229

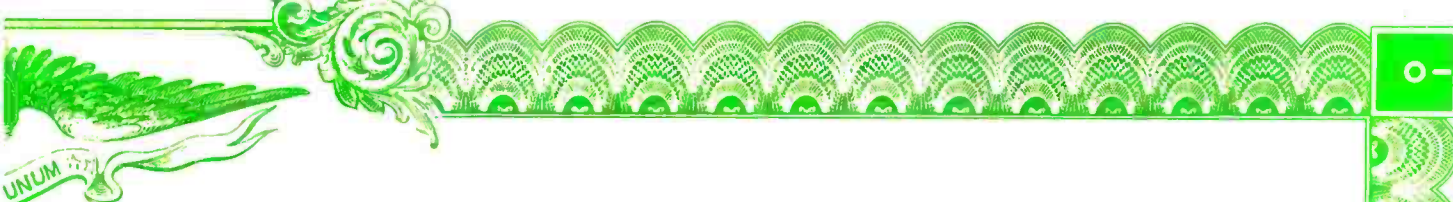

PRICES GUARANTEED

These remarkable savings represent only half the story of Discount Software. The other half is our reputation for prompt, courteous, and informative service. We are always available, always ready to help.

String/80	\$84
String/80 (source)	\$279
ISIS CP/M Utility	\$199
Lynx	\$199
Supervyz	\$95
ATI Power (tutorial)	\$75
Mathe Magic	\$95
CIS Cobol	\$765
Forms II	\$179
Basic	\$149
Zip MBasic, CBasic (each)	\$129

PEACHTREE	
G/L, A/R, A/P, PAY, (each)	\$399
PeachPack P40	\$349
ACCOUNTING PLUS	
G/L, AR, AP, INV, (each)	\$385
"OTHER GOODIES"	
Dow Jones	\$314
Incredible Jack	\$129
Super-Text II	\$127
Data Factory	\$269
Mini Factory	\$139
DB Master	\$184
Versaform VS1	\$350

Pascal (MSDOS)	\$429
Fortran (MSDOS)	\$429
"C" (MSDOS)	\$429
"OTHER GOODIES"	
SuperCalc II	\$265
VisiCalc	\$219
Visiplot/trend	\$259
Visidex	\$219
Easyfiler	\$359
Mathemagic	\$95
dBase II	Call 4??
Friday!	\$265
Statpak	\$449
Optimizer	\$174
Desktop Plan	\$259

APPLE II

ASHTON-TATE	
(See CP/M Ashton-Tate)	
BRODERBUND	
G/L (with A/P)	\$444
Payroll	\$355

INFO UNLIMITED	
EasyWriter (Prof)	\$155
EasyMailer (Prof)	\$129
Datadex	\$134

MICROSOFT	
Softcard (Z-80 CP/M)	\$249
Fortran	\$179
Cobol	\$549
Tasc	\$139
Premium Package	\$549
RAM Card	\$89

MICROPRO	
(See CP/M Micropro)	
Z-80 Card	\$299

VISICORP	
Visicalc 3.3	\$189
Desktop/Plan II	\$219
Visiterm	\$90
Visidex	\$219
Visitrend/Visiplot	\$259
Visifile	\$219
Visischedule	\$259

IBM PC, 16 BIT 8" DISPLAYWRITER

"WORD PROCESSING"	
Wordstar	\$289
Spellstar	\$199
Mailmerge	\$179
Easywriter	\$299
Easyspeller	\$159
Select/Superspell	\$535
Write On	\$115
Spellguard	\$189
Spellbinder	\$349
Final Word	\$264
Wordex	\$159
Edix	\$159

"LANGUAGES & UTILITIES"	
Crosstalk	\$139
Move-it	\$129
BSTAM or BSTMS	\$149
Pascal MT+ /86, SPP	\$679
CBasic 86	\$294
Act 86	\$157
Trans 86	\$115
XLT 86	\$135
MBasic (MSDOS)	\$329
MBasic Compiler (MSDOS)	\$329
Cobol (MSDOS)	\$649

FORMATS AVAILABLE.*

- 8" single density
- 8" OSI
- Superbrain
- Micropolis/Vector Graphic
- NorthStar Horizon
- NorthStar Advantage
- Osborne
- Heath/Zenith
- Cromemco
- Televideo
- Xerox 820
- Dynabyte
- Hewlett-Packard 125
- NEC
- Eagle
- Apple II/III
- Otrona
- TRS-80 Model I/II/III
- DEC VT-180
- Altos
- CP/M-86
- IBM PC

*New formats added weekly. Call for information.

FREE WITH PURCHASE:

Complete Software Buyer's Guide (\$5.00 value)
Filled with facts and usable advice about scores and scores of software programs from accounting and business systems to word processing and utilities.

Exclusive Service "Hotline"
Our reputation for courteous and knowledgeable service has resulted in calls from people who never purchased our products. Now a separate "hotline" is available to customers only.

Confidential Software BargainGrams
Regular notices of insider's bargains not available to the general public.



ORDER TOLL-FREE VIA VISA OR MASTERCARD:

1 800 421-4003

or 1 213-837-5141

Calif: 1 800 252-4092

6520 Selma Avenue, Los Angeles, CA 90028

Circle 146 on inquiry card.

DISCOUNT SOFTWARE
Outside Continental U.S.—add \$10 plus Air Parcel Post. Add \$3.50 postage and handling per each item. California residents add 6% sales tax. Allow 2 weeks on checks. C.O.D. \$3.00 extra. Prices subject to change without notice. All items subject to availability. *Mfr. trademark. Blue Label \$3.00 additional per item. CP/M is a registered trademark of DIGITAL RESEARCH, INC.

BM 883

SOFTWARE

What Is a Software Tool?

Develop your own problem-solving programming tools.

by Rebecca Thomas

The dictionary describes a tool as anything employed in performing an operation. A software tool is a program that is used to perform the operation of solving a data-processing problem. But this definition is too general for the purposes of this article because most commercial software packages would be considered software tools by this definition.

The type of software tools I'll describe here are programs that specifically aid the programmer in the development of other programs. These programs are designed to work well together.

Large programs such as operating systems and language compilers are technically software tools. In particular, the most important software tool is a good structured programming language. I'll describe how to use the Unix system and C programming language to develop software tools.

The Unix Environment and Productivity

The C programming language, the Unix operating system, and the numerous utility programs (software tools) together provide a very productive programming environment. These elements constitute the Unix development system, which promotes productivity by providing a friendly environment and quality tools for sophisticated software problem solving. The Unix system is one, and perhaps the only, operating system that actually assists in solving problems rather than presenting itself as a problem to overcome.

Build Tools and Use Them

The most widely used Unix tools are the programs for manipulation of text. Line and screen-oriented editors create and change text, a stream editor and other utilities transform text, several programs analyze text files statistically, and powerful formatting programs produce high-quality hard copy suitable for publication.

Your first step in understanding and using software tools is to master the rich set of tools that comes with the Unix system. Then don't hesitate to build new tools as your skill increases to help with your daily programming tasks. It is often tempting to use unskilled labor (yourself included in this context) to manually perform a task instead of stopping to build a tool that automatically performs the same task. If a tool of some general utility can be built, this tool then becomes a useful addition to your ever-growing software toolbox.

The Unix Shell

A brief discussion of the Unix shell should make clear how this command interpreter can be used to manipulate the software tool utilities. The Unix shell is actually a program itself that interprets user commands, calls programs into memory, and executes them one at a time or in series.

The Unix shell can be employed interactively as a command language to provide an efficient interface to the facilities of the operating system. In addition, it can be used in a "batch mode" to execute files of commands. In the latter context, the shell functions as a programming language that provides control-flow primitives (including while-do, if-then-else, for-do, and a case statement), string-valued variables, and parameter passing from the command line. I'll restrict my discussion to the interactive command language of this powerful command in-

A Complete Graphics Department For Just \$2295



Realize day-in and day-out solid performance from a quiet and capable desktop plotter. It's true. For only \$2295* the Houston Instrument HIPLØT™ DMP-29 will provide you with world-class multi-color hard copy graphics, and deliver a level of quality and performance that you would expect in a plotter costing three times as much.

It's a hard worker. The DMP-29 goes about its job with amazing speed and precision. Unbeatable resolution and repeatability are yours in both 8½" x 11" and 11" x 17" formats, and 8-pen capability assures you of fast attention-free flexibility when multi-color output is required. High pen speed combined with an addressable resolution of 0.001" assures fast, accurate and stepless traces.

It's friendly. You can call 21 different functions directly from the front-panel membrane keyboard. It's tolerant too. The DMP-29 will modestly protect itself from user errors, as when attempting to place a pen in an already occupied stall.

And it's smart. An extensive set of firmware routines makes life easier for the user. A small sampling of the built-in talent inherent in the DMP-29 includes character generation, circle, arc and ellipse synthesis, line type variations, viewport/windowing, clipping and scaling.

For the name, address and phone number of your nearest distributor/dealer, write Houston Instrument, 8500 Cameron Road, Austin, Texas 78753. Phone 512-835-0900, or 1-800-531-5205 if outside Texas. In Europe contact Bausch & Lomb Belgium NV., Rochesterlaan 6, 8240 Gistel, Belgium. Tel 059-27-74-45. Tlx 846-81399.

BAUSCH & LOMB 
houston instrument *division*

Circle 45 on inquiry card.

* U.S. Domestic price only
™ Trademark of Houston Instrument

terpreter. In some cases the algorithms proposed for a C language software tool can be tested by using the shell to execute a file of Unix commands to simulate the behavior of the algorithms. After debugging, you can code the algorithms in C.

The Unix software tools have a common invocation structure, which is based on how the shell invokes and executes programs. Simple shell commands are written as a series of "words" separated by white space (blanks or tabs):

(command name) (flags or options) (arguments)

These are three basic command-line elements for invoking a software tool. The command name is always required and represents the name of an executable binary program or perhaps a file of shell commands. The flags or options are specified next and generally cause some modifying action of the basic command. Usually the absence of an option indicates that the default action for the command is desired. Not all commands take modifying options. Finally, arguments might be required on the command line to specify, say, the identity of input or output files or devices.

Simple Unix commands such as `date` (print date and time) and `who` (who is currently logged on the system) require only that you type their name followed by a carriage return:

```
$ date
$ who
```

(Note: I will use \$ as the shell command prompt for the Unix system.) Other command lines call utilities that can take options, such as `du` (summarize disk usage), `ls` (list contents of directory), `ps` (process status), and `stty` (set terminal options). For example, some command lines and their options are

```
$ du -s      (summary option)
$ ls -ld    (long listing as directory)
$ ps -aux   (long listing of all processes)
$ ps -l     (long listing of owners' processes)
$ stty erase '^h' (set erase character to backspace)
```

Finally consider the following commands, which may require specification of file arguments: `cat` (catenate and display file), `cp` (file copy), `mv` (move or rename files), `rm` (remove file), and `wc` (word count). With file arguments, simple command lines are

```
$ cat file1 file2      (display contents of file1 followed by that of file2)
$ cp srcfile destfile (copy contents of srcfile to destfile)
$ mv oldname newname  (rename file oldname to newname)
$ wc -l textfile       (count lines in textfile)
$ rm -i oldfile        (interactively delete oldfile with query)
```

Design Tools as Filters

I'll design a filter program as the first example of a software tool. In a filter program, the input data comes from the standard input file (the keyboard, by default) and output data is directed to the standard output file (terminal screen, by default). The filter program performs some suitable transformation of the data passing through. In this way, the output of any one utility program may become the input to a different program. The Unix shell will establish the necessary connection (data paths, or pipeline) between the programs. In fact, the utility program may never be aware of where its data is actually coming from or going to. Rather, the tool considers the input and output (I/O) to be associated with the standard I/O files.

You can see the command line for accomplishing the task and an example of some actual results in this sample display of a terminal screen:

```
$ who
root      tty00      Mar 29 10:30
avante    ttyh5      Mar 29 10:03
vance     ttyhc      Mar 29 10:39
avante    ttyi3      Mar 29 10:27
becca     ttyi4      Mar 29 11:01
consult   ttyi9      Mar 29 11:08
```

```
$ who | sort
avante    ttyh5      Mar 29 10:03
avante    ttyi3      Mar 29 10:27
becca     ttyi4      Mar 29 11:01
consult   ttyi       Mar 29 11:08
root      tty00      Mar 29 10:30
vance     ttyhc      Mar 29 10:39
$
```

The first example, with just the `who` command, has the output sorted according to the second field (terminal designation). By using the `sort` command, you can have the second example reorder the file by the first field (the log-in name).

This use of filter tools necessitates restriction of program output to a bare minimum. For example, the `who` command produces one line of output for each user logged in to the Unix system. Thus, to obtain just the number of users, pass the output of `who` into the input of `wc`, the word count program employing the option to just count lines of input:

```
$ who | wc -l
6
$
```

If the `who` command output included a header containing the date and time, column headings, etc., more information would be at hand. However, then the number of output lines would no longer directly reflect the number of users. Instead it is best to use other utilities

The UCSD p-System. With Speed.



The new NCI implementation of the p-System. For IBM personal computers and compatibles.

NCI now makes the UCSD p-System run 1½ to 5 times faster on the IBM Personal Computer, including the new XT model and compatibles like Corona, Columbia, Compaq, Colby, Dot, Hyperion and Victor 9000. This speed is possible only with our new interpreter.

NCI includes more features for your PC.

NCI offers a wide range of software and hardware support that lets you tailor the p-System to your needs, including:

- HARD DISK SUPPORT compatible with most hard disk suppliers, including IBM Personal Computer XT, Corona, Davong, Corvus-Systems

and Tallgrass Technologies.

- AUTOMATIC RAMdisk SUPPORT (up to 512K) stores files for much faster access.
- PRINT BUFFER (up to 64K) eliminates printing bottlenecks.
- 8087 SUPPORT speeds numeric and graphics applications.
- GRAPHICS SUPPORT with much faster Turtlegraphics software or Tektronix emulation for business and scientific applications.
- COMMUNICATIONS SUPPORT LIBRARY links computers across continents.
- NCI CUSTOMER SERVICE—we're there when you need us to support the most reliable p-System ever developed for the IBM PC.

For all the advantages of the NCI version B8 of the UCSD p-System call or write:

Network Consulting Inc.

Discovery Park, Suite 110-3700 Gilmore Way
Burnaby, B.C., Canada V5G 4M1. (604) 430-3466

NAME _____

COMPANY _____

ADDRESS _____

CITY _____ STATE _____

ZIP _____



NCI

Portability. Reliability. Speed.

such as date to obtain additional information independently of the who program.

A Software Tool Performs One Job Well

You should design each software tool to perform a specific task as well as possible. If a different task is to be performed then a different tool (program) should be developed. This approach helps to avoid the messy "Band-Aid" program, which may be the result of adding too many new features to an existing software tool. For example, the Unix C compiler doesn't have any output listing. Instead, you would use other programs (tools) to generate symbol tables, etc.

It may not always be obvious how to best interpret the "one-task-well" guideline. For instance, programmers frequently require a source-code listing containing a line number at the beginning of each line. Here, the question might be raised, should another option be added to an existing tool such as cat to produce line numbering or should a dedicated line-numbering filter be developed? The best answer may depend in part on the tools that already exist and the best method of incorporating the line-numbering utility into the system.

Design for Early Testing

Design the software tool, no matter how complicated, so that some or all of it can be tested early in the design

APPLE IIe 	IBM P/C-XT 	NEW PORTABLE 
ON SALE \$1149.00	CALL NOW FOR SALE PRICE	COLUMBIA VP \$2359.00
COMPUTERS		
Apple compatibles..... 450 & up	APPLE ACCESS. AND SOFTWARE	
Columbia 1600-1..... 2295	M.S. Prem. Softcard..... 359	Ultraterm by Videx..... 289
Kaypro II or 10..... Sale!	Slimline 5W [®]	
Pled Piper by STM..... 1089	1 year warranty..... 289	Z-80 card..... 99
SKS P/C Portable..... New!	Graphic Printer card..... 99	Wordstar w/appl card..... 349
Corona..... 1995	30 to 60% of software..... Call!	
Zorba..... 1895	IBM ACCESS. AND SOFTWARE	
Eagle PC-XL..... 3395	USI multi display card..... 349	1st Mate by Teacmar..... 259
DEC Rainbow 100..... Call	Expansion Chassis..... 729	Quadlink by Quadram..... Call
Hyperion..... 4200	Mice?..... Call Us	Monte Carlo 64K..... 389
Epson QX-10 w/validox Sale!	Wordstar..... 239	The Home Acct..... 109
IBM, Apple are registered trade marks.	SPECIAL	
PRINTERS	New Micro-Sci..... Wow!	5W [®] Sentinel SS/DD (box 10)..... 25
Gemini 10x..... 299	Call For Secret Savings	
NEC 3550..... 799		
Silver-Read 550..... 729		
And More..... Just Call!		
MONITORS		
Princeton Graphics HX-12..... 499		
HI-RES Amber..... 129		
Composite Color..... 289		
RGB..... Best Buy		
BUY DIRECT AND SAVE	For Complete Selection and Lowest Prices — Free Catalog	
All prices and products subject to change and availability.	COMPUTERS and more	
TO ORDER (619) 291-1442	2420 University Ave., Suite 3, San Diego, Ca. 92104	

cycle. It would be advantageous if this first testing phase could begin within a few weeks of starting a project. In this way, you will spot algorithms that do not work as expected early so that they can be changed or even discarded. It is often prudent to discard awkward code and start over with a fresh approach based on the design experience to date.

Coding Guidelines

The tool program should be broken down into modules of code, which help simplify a program development task by controlling its complexity. Some coding guidelines are as follows:

- Use the logical control structures that the C language provides instead of the goto statement.
- A function should be moderate in size (say, less than 100 lines long and preferably smaller). This is so that the function can be easily comprehended as a whole.
- The functions that make up the module should be closely related, and the resulting module should represent one functional unit of the program.
- Both the functions and modules should be as independent of each other as possible. In this way, a change in one function or module of code will have minimal effect on other functions or modules. If it is necessary to share, for example, data structures between modules, then the interface to these structures should be clearly visible and well defined. In this way, the program will be easier to change at a later date.
- All the programs should be designed to work together so that a complicated task can be solved by suitably combining existing programs. In this context each program appears as a module, which interfaces with other programs via a simple well-defined interface.

Write code that is as clear and simple as possible and still does the job. The C language code, especially, may be written in a very obtuse, terse manner, which makes it almost incomprehensible. Such an algorithm could probably be expressed simply. Obviously, the simple approach is more desirable because other programmers (or you) may be called upon to maintain or modify your programs.

Build the program in steps that are manageable. Develop the central theme first, leaving the embellishments for later. In this way, the portion that is constructed first can be tested and even used in a production sense as soon as possible.

Don't reinvent the wheel. That is, if possible, start with existing modules or programs, modifying them as desired.

Portable Tools

You should design the software tools to be portable. To help achieve this end, the interface to the operating system should be clearly defined and localized within

System Saver[®]

The most important peripheral for your Apple II and IIe.

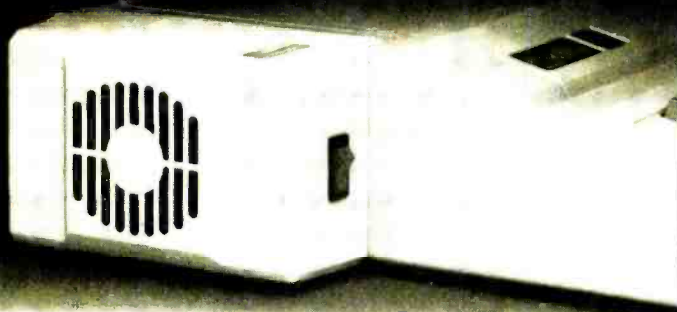

For Line Surge Suppression

SYSTEM SAVER provides essential protection to hardware and data from dangerous power surges and spikes. Dangerous voltage spikes are clipped off at a safe 130 Volts RMS/175 Volts dc level. High frequency noise is smoothed out before reaching the Apple II.

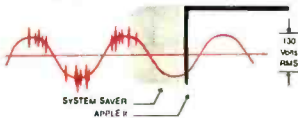

For Cooling

Today's advanced peripheral cards generate more heat. In addition, the cards block any natural air flow through the Apple II creating high temperature conditions that substantially reduce the life of the cards and computer itself. SYSTEM SAVER's fan exhausts 15 cubic feet of air per minute.

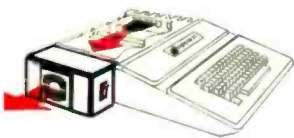

For Operating Efficiency

SYSTEM SAVER contains two switched power outlets. SYSTEM SAVER efficiently organizes your system so that one convenient, front mounted power switch controls SYSTEM SAVER, Apple II, monitor and printer. The heavy duty switch has a pilot light to alert when system is on. You'll never use the Apple power switch again. Also available in 220/240 Volt, 50/60 Hz.

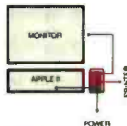

Easy Installation

Just clips on. Color matched to Apple II.

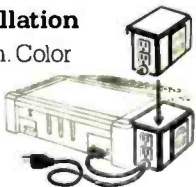

Fits on Apple Stand



Listing 1: The file copy filter program, copy. Written in the C language, the program uses Unix I/O routines to transfer data a character at a time from the keyboard to the terminal screen.

```
$ cat COPY.C
#include <stdio.h>
main()
{
    int c;
    while ((c = setchar()) != EOF)
        putchar(c);
}
```

the code. For example, if you use input and output routines from the Unix standard I/O library, then portability between Unix systems is virtually guaranteed. Even if the software tool is to be written for a non-Unix environment, you should restrict all code that interacts with the operating system to a minimum number of modular functions.

Primitives

For the purposes of this article a primitive is code that deals with the interface between the software tool and the operating system environment. You may use primitives to enhance portability of the software-tool program by restricting all system-dependent code to a few modules. In this way, only the system-dependent primitives need to be rewritten when moving the tool program to a foreign programming environment.

File Copy Filter

The trivial-looking example in listing 1 provides the basis for the tool programs I'll discuss. (For this and the examples that follow, I'll use the standard I/O library from the Unix environment. If you are working in a different environment, use the equivalent basic primitives for I/O.) Basically, the copy program transfers data a character at a time from a standard input file (the keyboard, by default) to a standard output file (the terminal screen, by default). I am employing two primitives from the Unix standard I/O library: `getchar()`, which reads the next input character, and `putchar(c)`, which outputs a single character. In listing 1, the line `#include <stdio.h>` directs the C compiler preprocessor to add the standard I/O library definitions directly to the source file before actual compilation begins.

Note that `c` is declared as an integer. This is necessary in order to have an end-of-input code, `EOF=-1` in this case, which is distinct from any valid character value. Also note that the standard library routine `getchar()` actually returns an integer value.

I/O Redirection

The Unix shell maintains three open files for each program it invokes: the standard input file, the standard output file, and a standard error file. Recall that this basic file-copy program reads characters from the standard input file and writes them to the standard output file. The Unix shell can be easily instructed to redirect input

\$89.95 at dealers everywhere or order direct by phone or mail. For phone or mail orders include \$2.50 for handling. New York State residents add sales tax. VISA and MASTERCARD accepted. Dealer inquiries invited.

KENSINGTON
MICROWARE

919 Third Avenue • New York, NY 10022 • (212) 486-7707
Telex: 236200 KEN UR

NOW
AVAILABLE FOR
IBM P.C.

NOW
AVAILABLE FOR
IBM P.C.

DBPlus™

SORT, COMPRESS, and TRANSFORM dBASE II™ DATA FILES

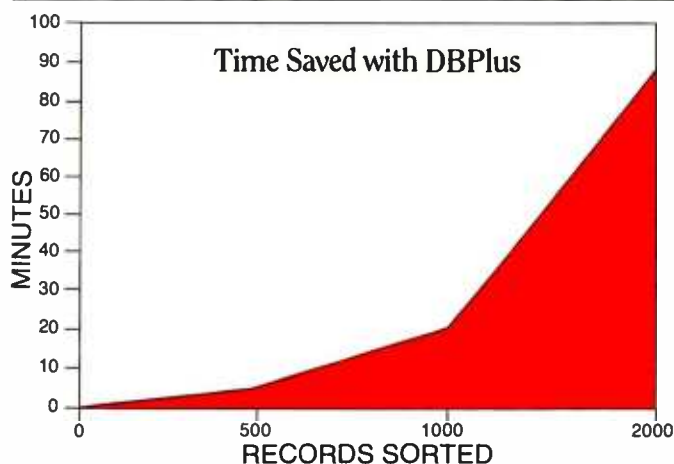

If you are serious about dBASE II™ you need DBPlus. This program runs outside of dBASE II™ and performs the following important functions on dBASE II™ data files:

- **Sort**
- **Compress/Decompress**
- **Transform**

DBPlus™ is designed to free you from the chore of typing or memorizing a new language. In most cases all you have to do is move the cursor to the next menu item and press return!

SORT

DBPlus™ can sort a data file up to 15 times faster than dBASE II™ on a single field; 32 fields may be sorted in a single pass and each additional field requires 1% more sorting time.

COMPRESS/DECOMPRESS

A copy of any dBASE II™ data file can be produced which is only 30% to 40% of the original size.

The compressed file will save you transmission time and phone costs when you send a data file over a modem.

Making backup copies of large data files can use up many floppy disks. Compressed files will save you space in archival storage.

TRANSFORM

You can now modify the structure of any data file by adding, deleting, and modifying fields without any programming knowledge.

DBPlus™ can also create a new file which is compatible with WordStar/MailMerge.™

Now retailing for \$125.

Manual and demo available.

Call for the name of a dealer near you.

Dealer and distributor inquiries invited!

HumanSoft

661 Massachusetts Avenue
Arlington, Mass. 02174
(617) 641-1880

dBASE II is a registered trademark of AshtonTate, Inc.
WordStar/MailMerge is a registered trademark of MicroPro, Inc.
DBPlus is a registered trademark of HumanSoft

Available from: Software Distributors 1-800-421-0814
France: La Commande Electronique
5 Villa Des Entrepreneurs
75015 Paris, France
Tel: (1) 577.31.82

Software Wholesalers 1-800-633-1000
Japan: JSE Int'l
9F Toyo Bldg. 6-12-20 Jingmae
Shibuya-ku Tokyo, Japan 150
Tel: (03) 486-7151

Germany: M&T Software Verlag
Hans-Pinsel-Strausse 2
8013 Haar bei Munich, West Germany
Tel: 089-4613-0

Available in popular formats

Circle 196 on Inquiry card.

and/or output for the copy program. This redirection capability of the shell greatly enhances the utility of a program even as simple as copy.

The shell redirects input or output by closing the original standard input and/or output file and opening the other files specified on the command line in its place. In this way, the program that the shell invokes is completely unaware of the redirected input or output.

For example, assume you want to quickly put a few lines in a disk file named message. The invocation command line would be

```
$ copy >message
```

Characters entered from the keyboard (standard input) would be written to the disk file message. When text entry was complete, the operator would give the end-of-file code (a Control-D in Unix), and the copy program would exit. Input could also be redirected. In fact, you could check the contents of the file you just created by rechanneling input from the disk file message instead of the keyboard. Here the command line would be

```
$ copy <message
```

The contents of the disk file are read by copy and sent to the terminal screen (standard output file).

The shell can redirect both input and output

simultaneously so that copy could be used to easily produce another instance of the disk file message as a backup. For example:

```
$ copy <message >message.bak
```

Now you have seen how a program as simple as copy is quite useful in its own right. You have also seen that with the aid of the Unix shell this program can be used to copy a character stream from virtually any source to any destination (if it can be specified as a file). In the Unix system, even all physical I/O devices are treated as files so that they can be easily accessed by specifying special-device file names on the shell command line.

The page Program

The copy program can serve as a model for constructing more complicated tools. Here again my philosophy is to use primitives that can read from an arbitrary input and can write to an arbitrary output destination. In this way, the tools are most flexible and work best together.

For the next example, let's create the page program (see listing 2) by adding the more() function, which counts the characters sent to the output. When a screenful has passed, the output is suspended, and the function command() is called, instructing the program to await operator intervention. If the operator presses the space bar, another screenful will be displayed, or if the return key is pressed, only one additional line will be shown. Obviously, this simple program lacks many embellishments required for a production version; however, it does serve to illustrate the evolution of a more complex tool from a simple one.

The page program requires an additional I/O channel (open file) to be attached to the keyboard. Thus the statement

```
20 fd = open("/dev/tty", 0);
```

returns a file descriptor for reading the terminal (/dev/tty). If the standard input channel is used for all input (including the operator response to the query for "more?"), then the display would never stop after one screen or line because the answer to the query would be supplied by the file passing through the filter.

The function command() reads characters from the alternate keyboard input shown opened in line 20 of listing 2 as depicted by the statement

```
48 while (read(fd,&c,1) && c != ' ' && c != '\n' && c != EOF)
49
```

This statement causes a character to be read into the location pointed to by &c. If the character is not a space (' '), a newline ('\n') or EOF (the end-of-file code, -1), then it will remain in the while loop. A space character causes the line counter to be reset so that another entire screenful will be displayed, as follows:

LETTER QUALITY

STARTING AT **\$599!**



- Daisywheel printer / portable typewriter
- Centronics and Wordstar™ compatible
- **OLIVETTI APPROVED**
- Based on the popular Olivetti Praxis series
- **ArkPrinter™ I** w/ portable carrying case **\$599***
- **ArkPrinter II** w/ switch selectable pitch **\$645***
- **ArkPrinter III** Durable office quality **\$699***
- Already own an Olivetti Praxis typewriter? We offer an easy-to-install interface kit (no soldering) for just \$195. **

TO ORDER CONTACT:

In Michigan Call (313) 769-7253



MICROSYSTEMS, INC.
P.O. BOX 4190
ANN ARBOR, MI 48106

CALL TOLL FREE
1-800-CALL-ARK

COMPARE & SAVE



*add \$10.00 for shipping
**for an additional \$25.00 our factory trained technicians will install this for you.



A FULL CAST OF STAR PERFORMERS

The Esprit product line has the right performer for every terminal role. It begins with *Esprit I*, an editing terminal at a conversational price. This basic Esprit presents crisp, clear video in comfortable green phosphor on a 12" diagonal screen. The integral typewriter keyboard has a 14-key numeric pad with alternate function key modes. *Esprit II* delivers additional editing features, plus the convenience of a detached keyboard; enhancements you'll appreciate in data entry. *Esprit III* meets a wide range of terminal applications. It costs much less than a TVI 925, but gives a significantly stronger performance including line drawing graphics, a broad repertoire of video attributes and editing commands, 22 user definable function keys and an optional 4-page display memory. *Esprit III COLOR* delivers the full Esprit III performance in eight brilliant colors.

There's an Esprit that's ready to star in all your terminal roles. Auditions are being held by your Esprit dealer right now.

Esprit Systems, Inc., Hazeltine Terminals Division, 100 Marcus Drive, Melville, NY 11747 (516) 293-5600

Esprit Systems, Inc.
Hazeltine Terminals Division

Pick up a SixPakPlus™

Introducing... **SixPakPlus™**, the refreshing new **384KB multifunction card!** In response to the changing needs of the IBM PC and PC-XT marketplace, AST Research, Inc. is proud to announce the latest addition to our line of multifunction enhancement products, the **SixPakPlus!** This new product is the result of extensive marketing research into the needs of IBM PC users whether they have the original 64K system board, the newer 256K system board, or the PC-XT. The

SixPakPlus has been engineered to meet these needs at a competitive price while maintaining AST's high standards for quality and reliability.

The **SixPak**, as we like to call it, could have been named for the six banks of RAM on it. However, we like to think that it was named for the six functions of the card.



for your IBM® PC.

The features of the **SixPak** include:



1. RAM memory starting at 64K, user-expandable in 64K increments to 384K. This makes the **SixPak** ideal for the PC or PC-XT with a 256K system board; 384K on a **SixPak** added to 256K on the system board yields 640K, the maximum addressable user memory in these systems.

2. One Serial (async) communications port, configurable as either COM1 or COM2, for use with serial printers, modems, a "mouse," and other serial devices. The serial port has on-board jumpers for easy management of the RS-232C lines, simplifying the wiring of cables in many installations.

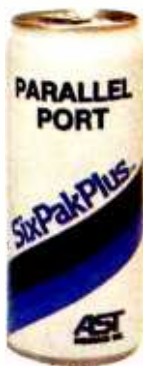

3. One Parallel (printer) port, configurable as LPT1 or LPT2 (LPT2 or LPT3 when the IBM monochrome card is installed), for use with the IBM/Epson and other compatible printers. The port is compatible with IBM diagnostics.

4. A Clock-Calendar with battery backup, featuring an easily replaceable Lithium battery and a quartz-controlled timebase for a high degree of accuracy.



5. An optional IBM-compatible Game Adapter port, for use with an IBM-type joystick. In conjunction with application programming, this game port may be used for cursor control, in generating graphics or for playing games at the end of your work day!

6. Every **SixPak** comes with an AST SuperPak utility diskette which includes SuperDrive and SuperSpool, the most powerful disk emulator and print spooler software you can get. These programs will greatly enhance the throughput of your PC or PC-XT by emulating disk drive and printer access at RAM speeds rather than the normal slower speed of mechanical devices. SuperPak is the first of such software to be compatible with both DOS 1.1 and DOS 2.0.



Most important of all, the **SixPak** comes with the AST "Plus," AST's unsurpassed reputation for quality, reliability, after-the-sale support, and overall design excellence that gives our products the best price/performance ratio in the industry! Hence the name, **SixPakPlus!**

AST products are available from Computerland, Entre', ComputerMart, and selected dealers worldwide. Call factory if your dealer does not have the AST products you want.

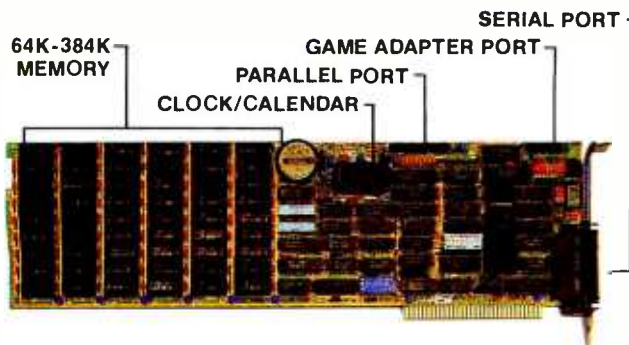

AST RESEARCH INC.

2372 Morse Avenue
Irvine, California 92714
(714) 540-1333 • TWX 295370ASTRUR
Dealer Inquiries Welcome

* IBM is the registered trademark of International Business Machines

Start ahead. Stay ahead.

The Columbia Family:
IBM-PC compatibility
plus outstanding value
and performance.



Today, Columbia offers you the highest level of IBM-PC hardware and software compatibility.

Each Columbia microcomputer is delivered with software worth thousands of dollars for word processing, financial planning, communications, and more.

Stay ahead with Columbia's economic multi-user capabilities and quality expansion products.

Choose the very practical Columbia VP Portable, \$2,995. Or, the flexible Columbia MPC, \$3,395. The Columbia MPC with hard disk is

\$4,995. All prices include CRT controller with graphics and keyboard.

Call (301) 992-3400 for the name of the dealer or distributor nearest you. Serviced and supported worldwide. National service by Bell & Howell Service Company.

World Headquarters:
9150 Rumsey Road
Columbia, MD 21045
(301) 992-3400
TWX 710-862-1891

West Coast:
3901 MacArthur Blvd.
Suite 211
Newport Beach, CA 92660
(714) 752-5245
Telex 277778

Europe:
Limitenstr. 94
4050 Moenchengladbach 2
West Germany
02166-47097
Telex 852452

COLUMBIA

DATA PRODUCTS, INC.

Distributors in Australia, Belgium, Colombia, Denmark, Hong Kong, Israel, Italy, Malaysia, Netherlands-Antilles, Norway, Portugal, Spain, Sweden, Switzerland, United Kingdom, Venezuela.

IBM and IBM PC are registered trademarks of International Business Machines.

www.americanradiohistory.com

Circle 381 on inquiry card.

Listing 2: The page program counts the characters sent to the output so that the operator can control the amount of information shown on the terminal screen.

```
$ cat -n page.c
 1  #include <stdio.h>
 2  #define LINESIZE 80
 3  #define SCRNSIZE 23
 4
 5  /*
 6   * Global variables:
 7   */
 8
 9  int c; /* The character */
10  int colcnt, linecnt; /* The counters */
11  int fd; /* The descriptor for the alternate key board input */
12
13  main(argc, argv)
14  int argc;
15  char **argv;
16  (
17      colcnt = 1;
18      linecnt = 0;
19
20      fd = open("/dev/tty", 0);
21
22      while ((c = getchar()) != EOF) (
23          putchar(c);
24          more();
25      )
26 )
27
28 more()
29 (
30     if (c == '\n') (
31         linecnt++;
32         colcnt = 1;
33     )
34     else (
35         colcnt++;
36         if (colcnt == LINESIZE) (
37             linecnt++;
38             colcnt = 1;
39         )
40     )
41     if (linecnt == SCRNSIZE)
42         command();
43 )
44
45 command()
46 (
47
48     while (read(fd,&c,1) && c != ' ' && c != '\n' && c != EOF)
49         ;
50
51     if (c == ' ')
52         linecnt = 0; /* reset counter */
53     else if (c == '\n')
54         linecnt--;
55     else
56         exit();
57 )
$ []
```

MITSUBISHI[®] DRIVES



M2892
1.6 MB, DS/DD
8" FULL HEIGHT
Floppy Disk Drive



M2896
1.6 MB, DS/DD
8" HALF HEIGHT
Floppy Disk Drive



M4854
1.6 MB, DS/DD
5 1/4" HALF HEIGHT
Floppy Disk Drive



M4851
500 KB, DS/DD
48 TPI
5 1/4" HALF HEIGHT
Floppy Disk Drive



M4853
1.0 MB, DS/DD
96 TPI
5 1/4" HALF HEIGHT
Floppy Disk Drive



M4852
1.0 MB, DS/DD
96 TPI
5 1/4" FULL HEIGHT
Floppy Disk Drive



M4855
2.0 MB, DS/DD
96 TPI
5 1/4" HALF HEIGHT
Floppy Disk Drive

AVAILABILITY: NOW
RELIABILITY: PROVEN
SERVICE: FACTORY AUTHORIZED

NCLDATA^{INC}
PHONE (408) 247-3450
1330 Lawrence Expressway, Suite 330
Santa Clara, California 95051

Text continued from page 230:

```
51         if (c == ' ')
52             linecnt = 0; /* reset counter */
```

Actually, because Unix usually requires you to type the line terminator before the keyboard is "read," a space followed by a carriage return must be typed to get the next screenful.

A *newline* is the Unix line terminator and is more or less equivalent to the CPM's carriage return/linefeed pair. When the response to the "more?" query is a newline (entered by typing the return key), one additional line will be displayed because the line counter is decremented by one:

```
53             else if (c == '\n')
54                 linecnt--;
```

The remaining possibility has to be the EOF code, which causes the page to exit:

```
55     else
56         exit( );
```

The concat Program

For the last example, I will introduce a few more primitives and illustrate how to transform the copy program into a more general utility, called the concat program, which can be employed to combine files specified on the command line and send them to the standard output (see listing 3).

In this example, I have added the function `getarg()`, which returns a pointer to the desired command-line argument. This approach is necessary so that functions besides `main()` can access the command-line variables without having to pass these same variables as additional arguments to functions outside of `main()`. Note that you need the function `allocarg()` to allocate space for the command-line argument(s). The actual copy operation is performed by `filecopy()`, which will copy the contents of the files (if specified) to the standard output file. If no files are designated on the command line when `concat` is invoked, then `concat` acts like the copy program introduced earlier.

Line 19 of listing 3 declares the variable `fp` to be a pointer to type `FILE` and `fopen()` to be a function that returns a pointer to a `FILE`. Now just what is `FILE`? First consider the definition of the array of `_iobuf` structures as defined in the include file `<stdio.h>`, which is actually located in `/usr/include/stdio.h`:

```
extern struct _iobuf {
    char *_ptr; /* next character position */
    int _cnt; /* number of characters left */
    char *_base; /* location of buffer */
    char _flag; /* mode of file access */
    char _fd; /* file descriptor */
} _iob[_NFILE];
```

Listing 3: The concat program. Building upon the original copy program, this expanded utility program can combine files and send the results to the standard output, in this case the terminal screen.

```
# cat -n concat.c
 1  #include <stdio.h>
 2
 3  /*
 4  * Command line arguments must be
 5  * external to all functions:
 6  */
 7
 8  int nargs; /* number of arguments */
 9  char **args; /* pointer to argument strings */
10
11 extern char *setarg();
12
13 main(argc, argv)
14 int argc;
15 char **argv;
16 {
17     int i;
18     char *strings;
19     FILE *fp, *fopen();
20
21     allocarg(argc, argv);
22
23     if (nargs == 1)
24         filecopy(stdin);
25     else
26         for (i = 1; i < nargs; i++) {
27             strings = setarg(i);
28             fp = fopen(strings, "r");
29             filecopy(fp);
30             fclose(fp);
31         }
32 }
33
34 allocarg(argc, argv)
35 int argc;
36 char **argv;
37 {
38     int i;
39     char *calloc(), *malloc(), *strcpy();
40
41     nargs = argc;
42     args = (char**) calloc((unsigned) argc, sizeof(char*))
43
44     for (i = 0; i < argc; i++) {
45         args[i] = malloc((unsigned) strlen(argv[i])+1)
46         strcpy(args[i], argv[i]);
47     }
48 }
49
50 char *setarg(n)
51 int n;
52 {
53     if (n > nargs)
54         return((char *)-1);
55     return(args[n]);
56 }
57
58 filecopy(filein)
59 FILE *filein;
60 {
61     register int c;
62
63     while ((c = getc(filein)) != EOF)
64         putc(c, stdout);
65 }
```

The include file further defines FILE to be an instance of this structure:

```
#define FILE struct _iobuf
```

Observe that the structure `_iobuf` contains information important to performing buffered I/O (also known as stream I/O). For instance, information such as the buffer location, the current character position in the buffer, the mode of file access (read/write), and the actual (low-level) file descriptor (which was used in the `page` program) is contained in this important structure.

Note that all names in the include file `stdio.h` intended for internal use begin with an underscore (`_`) to minimize the chance of conflict with user-defined names. Some of the important names intended to be used externally are

```
stdin (&_iobuf[0]) the standard input file (fd = 0)
stdout (&_iobuf[1]) the standard output file (fd = 1)
stderr (&_iobuf[2]) the standard error file (fd = 2)
EOF (-1) end-of-file value
NULL (0) the null pointer
BUFSIZ (512) recommended I/O buffer size
```

FILE is a convenient shorthand for declaring pointers to streams. Streams represent buffered I/O with output flushing where necessary.

The main processing loop for the `concat` program is reproduced here:

```
26 for (i = 1; i < nargs; i++) {
27     string = getarg(i);
28     fp = fopen(string, "r");
29     filecopy(fp);
30     fclose(fp);
31 }
```

For each command-line argument, (for `i = 1; i < nargs; i++`), a pointer to that argument, `string = getarg(i)`, is obtained. The string argument represents (you hope) a file that is opened for reading (`fp = fopen(string, "r")`). The func-

tion `filecopy()` actually performs the copying from the designated file to the standard output (see lines 63 and 64 in listing 3).

The `allocarg()` function is required to allocate storage for the external variables `nargs` and `argstr`. The Unix library routine `calloc()` allocates memory for an array of `argc` elements of size `sizeof(char*)`. The `malloc()` routine returns a pointer to a block of at least `strlen(argv[i]) + 1` bytes beginning on a word boundary. The `strcpy()` function actually makes the copy of the argument to the external variable `argstr`.

This last example nicely illustrates how the addition of a few primitive functions can transform the basic copy program into a very useful general-purpose tool with many of the same properties as the Unix `cat` utility program.

Summary

The software tools I've used as examples are very simple, but their design typifies the ease of use of the Unix environment. By carefully developing your software tools and adhering to good programming practice, you can design your own problem-solving tools. With these tools, you, the programmer, become the hammer rather than the anvil. ■

Dr. Rebecca Thomas (1839 10th Ave., San Francisco, CA 94122) is coauthor of the popular Unix guide for beginners, A User Guide to the Unix System (Osborne/McGraw-Hill, 1982). She is also coauthoring additional Unix titles to be available in 1983, including both a business user's and an application programmer's guide to both the Unix and Xenix systems, to be published by Addison-Wesley.

References

1. "The Bell System Technical Journal" Bell Laboratories, July 1978.
2. Brooks, F.P. *The Mythical Man-Month*. Reading, MA: Addison-Wesley, 1974.
3. Kernighan, B.W., and P.J. Plauger. *The Elements of Programming Style*. New York: McGraw-Hill, 1978.
4. Kernighan, B.W., and P.J. Plauger. *Software Tools in Pascal*. Reading, MA: Addison-Wesley, 1981.
5. Kernighan, B.W., and D.M. Ritchie. *The C Programming Language*. Englewood Cliffs, NJ: Prentice-Hall, 1978.
6. "The Unix Programmer's Manual," Bell Laboratories, 1978.

DATA TRANSFER PROBLEMS?

Your Simple Solution is **REFORMATTER**® Diskette Conversion Software



- Avoids serial communication protocols.
- Needs only one system to transfer data.
- Converts source code and data files.
- Allows 2-way transfer.
- Quick, reliable, and inexpensive.

VERSIONS

Runs On	Reads/Writes
CP/M	↔ IBM 3740
CP/M	↔ DEC RT-11
CP/M-86*	↔ IBM 3740
CROMIX	↔ DEC RT-11
DEC RT-11*	↔ CP/M
MS-DOS*	↔ IBM 3740
TRSDOS II	↔ CP/M
TRSDOS II	↔ DEC RT-11
PRICE:	\$249 *\$350

Requires 8" floppy drive.

(415) 324-9114 TWX: 910-370-7457

467 Hamilton Avenue, Suite 2, Palo Alto, Calif. 94301



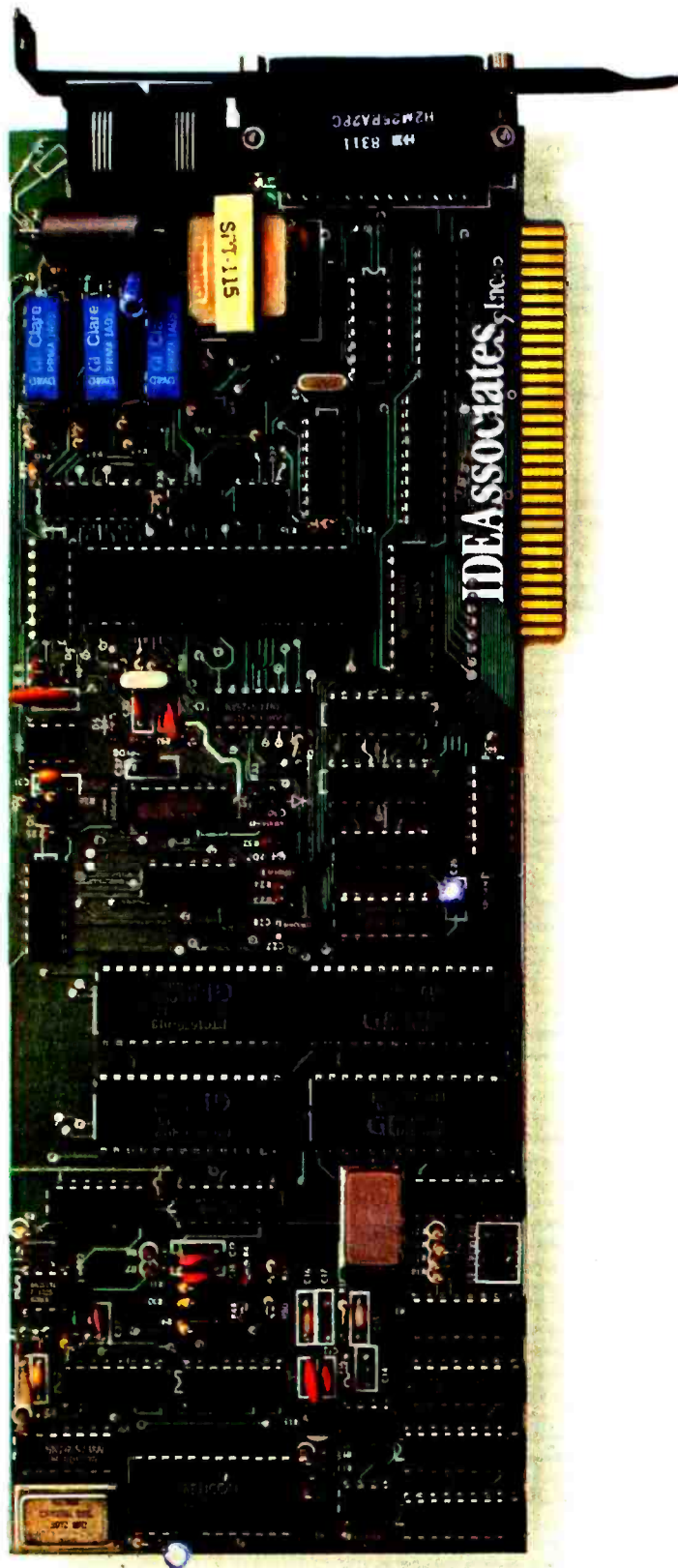

**Introduce your IBM-PC
to a fast-talking card sharp.**

The IDEComm 1200: Fast, reliable communications on a plug-in card.

Now you don't need an external modem to get 1200 baud communications capability for your IBM-PC. The IDEComm 1200 is an integral modem that combines the functions of an in-board asynchronous communications card and an out-board modem in one integrated plug-in unit. Snap it into an expansion slot, plug in a modular telephone jack, and you have direct 1200 or 300 baud communications without the confusion and added expense of external boxes and cables. And there are no switches to set; the speed is software-selectable or automatically selected by the card. Plus, we've designed in outstanding reliability: four powerful on-board microprocessors replace conventional analog circuitry with digital precision and reliability.

One Card That's a Great Deal

The fast-talking IDEComm 1200 is one sharp card: it eliminates the need for an external modem, gives you 1200/300 baud communications capability with the exceptional reliability of digital design; provides an additional plug so you don't lose regular telephone voice communications; and includes a standard RS232C interface and connector that can be used as an additional serial port. All for only \$545. That's about the cost of a conventional external modem alone, saving you the entire cost of the internal asynchronous card.

One Card Gives You a Full Hand

The IDEComm 1200 comes complete with software diskette enabling easy, menu-driven selection of all

Technical Specifications	
Speed 0-300 bps or 1200 bps	IBM Port COM 1
Data Format Serial, binary, 7-8 data bits, 1-2 stop bits	Modem Compatibility Bell System 103 or 212A in both Originate and Answer mode
Dialing Capability Touch-Tone (TM) or rotary dial pulse	Physical Data 3.9" x 10.8" x .6" (one card slot)
Operation Full Duplex	

communications, autodial, and auto log-on procedures, and easy recall at the touch of a single key. It also allows the IDEComm 1200 to work with most other terminal emulation packages—including IBM Comm 2.0 communications software.

We've Stacked Our Deck With Better Ideas

IDE's Better Ideas for your IBM-PC include expansion memory boards, "The IDEABoard" combination boards, fixed or removable Winchester disk drives for either internal or external mounting, and printer spooler and RAMFloppy disk emulation software. We have Better Ideas on product support, too. Superb technical support and documentation, including full programming specifications for the IDEComm 1200 . . . an aggressive pricing policy . . . a unique upgrade policy that lets you trade up any IDE product for another in our line . . . and our full year warranty.

Get the IDEA

To see IDE's Better Ideas for yourself, contact any of the knowledgeable dealers listed below. If there is no listing for a dealer near you, call us. We'll provide you with the name of your nearest dealer or take your order over the phone. **1-800-257-5027** (In Massachusetts, call 617-275-4430)



Removable Winchester disk drive



IDE Software



Expansion Memory Board

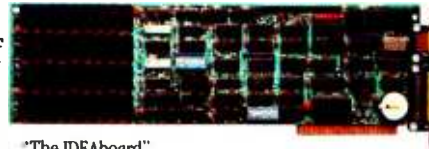

"The IDEABoard"

IDE
IDE Associates

Better ideas for personal computers.

IDEAssociates, Inc. 7 Oak Park Drive, Bedford, MA 01730

IDE Dealers: Alaska: VFM Electronics, Fairbanks Arizona: Abbot Data Products, Glendale; Computer Emporium, Tucson California: Q-Bits, Mountain View; Stoneware Ltd., La Jolla Connecticut: The Computer Establishment, Old Saybrook; MicroAge, Danbury; American Business Computers, Groton; Creative Systems, E. Granby Hawaii: Peripherals Hawaii, Kahuku Illinois: DM Micro Systems, Collinsville Iowa: ComputerLand, Des Moines Kansas: Computype, Manhattan Massachusetts: Arby Corporation, Cambridge; TEK Microsystems, Boston Michigan: The Computer Workshop, Houghton; TransNational Corp., Troy; Computer Rentals, Royal Oak Minnesota: Computer Depot/Daytons Computer Centers, Minneapolis, St. Paul, Burnsville Center, Ridgedale, Rosedale, Southdale Nebraska: ComputerLand, Lincoln; ComputerLand, Omaha New York: Future Data, NYC; Oppenheimer Software, NYC; Yankee Computer Services, Putnam Valley North Carolina: Surveyor's Supply, Apex; Computer South, Charlotte; Microcomputer Sales, Fayetteville; The Computer Exchange, Durham Ohio: U-Compute, Toledo Oklahoma: Advanced Financial Technology, Oklahoma City; Biologic Instruments, Stillwater Pennsylvania: Software Projections, Inc., Flourtown South Carolina: Berry's Office Automation, Lugoff South Dakota: Computer Terminal, Sioux Falls Tennessee: FICON, Nashville Texas: MicroSpec, Plano; Video Station, Plano; Southwest Automation, Houston Utah: Weidner Communications Corp., Provo Virginia: Micro Solutions, Reston Washington: Telecalc, Seattle

International Distributors: Austria, Switzerland, West Germany: Computer 2000 GmbH, Munich United Kingdom: KPG-Hardware House, London France: Micro Connection International, Paris Israel: O.D.C. Systems, Natanya

THE LEMON™ SOURS SURGES



Our crop-The Lemon™, The Lime™, and The Orange™ are designed to eliminate undetected submicrosecond overvoltage transients from electrical circuits. Commonly referred to as "spikes", or "glitches", these transients can cause hardware and software damage to unprotected circuits.

Today's electronic products are often microprocessor controlled - mini and micro computers, televisions, video cassette recorders - to name a few. Each of these products is sensitive to fluctuations in electrical power lines. Power switching devices such as refrigerators coming on and off or air conditioners starting up can be responsible for a momentary surge or spike of electricity in a circuit. Even your local

utility stepping-up transformers to add power at peak load times or an electrical storm passing through can trigger surges. Such surges can cause equipment to falter at times, not to work at peak performance or fail completely. An entire data base can be lost.

Now you can prevent this from happening to you with an AC Surge Protector from Electronic Protection Devices. Each Protector is a solid state clamping device with 6 outlets utilizing modern high speed semiconductor technology. Using our Protectors is as simple as plugging it into any standard three wire duplex outlet then plugging what needs protection into it. Each Protector exceeds the IEEE 587-1980 Guide for Surge Voltages in Low

Voltage AC Power Circuits.

When you compare the cost of computer hardware, software and your time with the price of a Protector (from \$59.95 to \$139.95), you'll want to sour your surges with one of the AC Surge Protectors from EPD, which are available through your local dealer.

Electronic Protection Devices

5 Central Avenue
Waltham, Massachusetts 02154

In Massachusetts Call:
(617) 891-6602

Outside Massachusetts Call:
1-800-343-1813

Dealer Inquiries Invited

The Unix C Compiler in a CP/M Environment

What subset of Unix version 7's compiler makes sense for CP/M?

·by Matthew Halfant

How much of the C programming language, as it exists under Bell Labs' version 7 Unix, can be made available under CP/M? To begin with, we must say what distinguishes Unix C from other implementations that follow the formal language definition. This is largely a matter of the "standard I/O library," though I maintain below that other groups of support functions must be considered as well. An examination of three C compilers for the CP/M environment (small-c, BDS C, and Aztec C) will give an idea how close the compilers actually come to version 7's C.

The Formal Side of C

For those without access to a Unix system, the principal source of information on C is the remarkable book *The C Programming Language* by Kernighan and Ritchie, referred to hereafter as simply K&R (see the references). I assume the reader to be familiar with this work. Appendix A of this book contains a formal definition of C, which is the place to turn for precise specifications of syntax, scope of identifiers, and other legal matters. This is not, however, the place to resolve a question on, say, the procedure for opening a file.

C does not specify the system interface: there are no built-in connections with terminals, printers, or files. These functions are supplied as library routines rather than innate parts of the compiler. Presumably, this simplifies the task of writing the compiler and allows flexibility in constructing the I/O (input/output) inter-

face. But it creates a potentially awkward situation: programs will not be portable between systems with widely divergent support libraries.

For this reason, Unix supplies the *standard I/O library* that is, according to chapter 7 of K&R, ". . . a set of functions designed to provide a standard I/O system for C programs . . . the routines are meant to be 'portable' in the sense that they will exist in compatible form on any system where C exists, and that programs that confine their system interactions to facilities provided by the standard library can be moved from one system to another essentially without change."

Adoption of this library is not obligatory; we have the example of Whitesmiths' C compiler, in which most of the standard functions have been renamed or redefined. The difficulty observed in moving a Whitesmiths program to a Unix system argues for formalizing the standard I/O library along with many other of the common functions described in K&R. (Editor's note: Whitesmiths recently released a new version of its compiler that will be more compatible with Unix version 7.) Such a project is the responsibility of the ANSI (American National Standards Institute) committee that was recently formed. I am not attempting to define a language standard here but merely describing the dialect of C that is spoken on Unix systems and devoting special attention to the subset that can be implemented under CP/M.

In the remarks of Kernighan and Ritchie quoted above, the terms "standard library" and "standard I/O library" are used interchangeably, whereas I would prefer "standard library" to designate the entire collection of support functions, of which the I/O library is a specific subset. Other members include the string-handling functions (`strcat()`, etc.), the math library (`sqrt()`, etc.), and a number of system calls. Some such collection of functions must be standardized if convenient portability is to be secured.

The Standard Library as Part of the C Language

To illustrate the importance of standardization, compare the treatment of character strings in C versus those in PL/I. The latter admits strings as a data type that may be assigned, transmitted as an argument, or returned by a function. In C, strings are implemented as null-terminated character arrays. Suppose I want to write a utility function to remove blanks from a string. I want to turn "this is a string" into "thisisastring". One strategy (I don't claim it to be optimal) is to operate in what might be called a "while there's still a blank in the string" loop in pseudocode. The loop body locates the leftmost blank, breaks the string into the part before the blank and the part after, and concatenates the two parts. In PL/I, I might write

```
do while(index(string, ' ') > 0);
```

We can help your little IBM C.

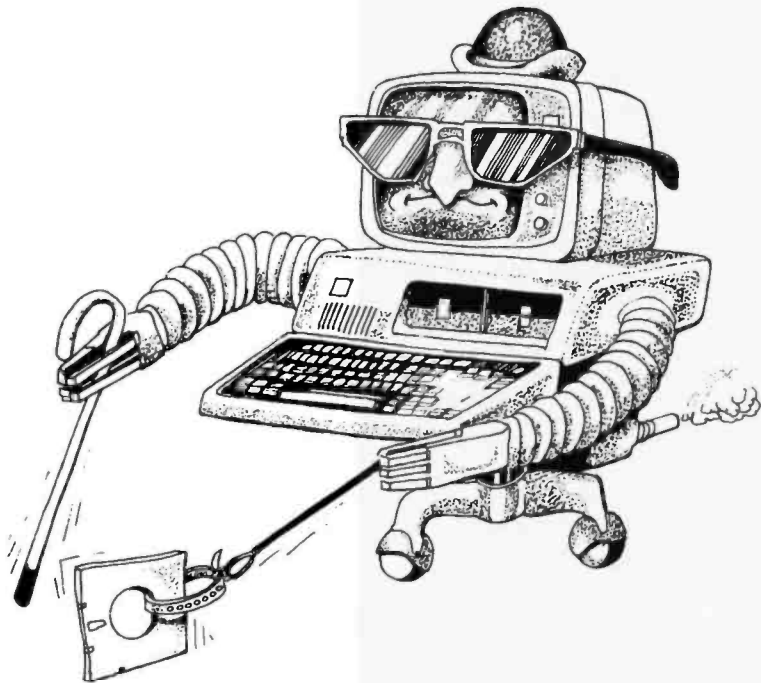

Powerful, portable and fast, C is the language of tomorrow!

With Computer Innovations' C86 compiler you'll have full unix-compatible C running on your PC or other 8086/8088 system. C86 is a complete implementation, with struct/union, bit fields, trig functions and floating point with 8087 support.

The source code for the run-time library is included — you pay no royalties on programs you produce!

C86 is only \$389, or \$399 with K&R "The C Programming Language" reference manual. And with each order we include a free copy of our powerful modem/file transfer program VaMP, a \$100 value!

Call us toll free or 1-800-426-5248. We'll help your PC "C" the light!

VISA, MasterCard and AMEX accepted.

For more information call:
(206) 542-7611 or write Vandata:
17544 Midvale Ave. N., Suite 107
Seattle, WA. 98133

unix is a trademark of Bell Laboratories.



```
i = index(string, ' ');
string = substr(string,1,i-1) ||
      substr (string,i+1);
end;
```

The concatenation operator || is part of the PL/I language, as are the "built-in" functions index() and substr().

In C I would use a similar method but would use the standard library functions index() (modeled on the above) and strcat():

```
while( (p=index(string," ")) != NULL) {
    *p++ = "\0";
    strcat(string,p);
}
```

Concatenation is achieved with a function call; assignment, when required, is done the same way (using strcpy()). As a C programmer, I come to regard functions like index() and strcat() as parts of the language, as is the case with their PL/I counterparts. Of course, they are not really parts of C as defined in Appendix A, but they do belong to Unix C, and I would expect to find them accompanying any C compiler advertised as Unix version 7 compatible.

What Is Meant by "Unix C"?

My intention is to use the phrase "Unix C" suggestively, rather than definitively, to encompass those features commonly used by C programmers in the Unix environment. To me, the Unix environment involves more than the union of C and the Unix standard library; it also includes certain system interface conventions, such as I/O redirection and the handling of command-line arguments. Such conventions become as indispensable as the standard library itself; thus, we begin our programs with

```
main(argc,argv)
int argc;
char *argv[ ];
{
```

and take advantage of getchar() and putchar() when writing filters that can be tested at the terminal before being applied to files or embedded in a pipe.

Where Is the Standard Library Defined?

K&R explicitly decline to describe the standard library in its entirety; moreover, several of the functions illustrated in the text differ in minor ways from those currently used. For example, the memory allocation function `alloc()` is named `malloc()` in version 7 Unix. A less trivial departure concerns the function `index()`: as shown on page 67 of K&R, it returns the integer index of the located substring (or -1 if none is found); under Unix version 7, `index()` returns a pointer to the located substring (or NULL if none is found). There are other inconsistencies of this kind.

The authoritative source for standard library definitions is Volume 1 of *The Unix Programmer's Manual*, which has recently been published in book form (see the references). This volume is divided into several sections, of which the ones on system calls (section 2) and subroutines (section 3) are relevant here. They enumerate the functions that may be invoked from within a C program, and thus comprise what I would speak of as the "standard library."

The special set of subroutines normally known as the "standard I/O library" consists of those items in section 3 denoted by the letter S, as in `SCANF(3S)`. A separate description of the standard I/O library can be found in Volume 2 of *The Unix Programmer's Manual*, a companion volume to the one mentioned above. Chapter 17, on Unix programming, is a tutorial along the lines of chapter 8 of K&R, but it covers additional ground. An appendix to that chapter, titled "The Standard I/O Library," contains a list that differs slightly from the conventions of Volume 1. For example, the listed function `system()` is not considered part of the I/O library in Volume 1. The same is true for the memory-allocation functions (see `MALLOC(3)`); what's more, the Appendix uses the name `cfree()` in place of `free()`.

in accessing system resources. For Unix, these are the system calls of section 2; they are analogous to the BDOS (basic disk operating system) calls of CP/M. The subroutines of section 3 provide a higher level of service to applications programs and are considered distinct from the system calls (by the systems programmers, at least). But this distinction, however relevant in the Unix domain, completely evaporates when we consider transporting the functions to CP/M,

for they must there be implemented as subroutines based on CP/M's own system interface.

Consider an especially important example: the low-level I/O interface. CP/M's view of reading and writing files is based on 128-byte logical sectors. Unix supports a more flexible approach: there are system calls to seek to an arbitrary byte boundary, and there to read or write an arbitrary number of bytes. These functions—`lseek()`, `read()`, and `write()`—can indeed



EXPOTEK

2723 W. Windrose Suite 3
Phoenix, Arizona 85029

1-800-528-8960





All Prices Subject To Change

COMPUTERS	PRINTERS
<p style="text-align: center; color: red; font-weight: bold;">ALTOS</p> <p>5-15D - \$2120 586 - 14 CALL 580-10 - \$4695 586-10 - \$5698 580-14 - \$9395 8600-12 - \$8950</p> <p style="text-align: center; color: red; font-weight: bold;">NORTHSTAR</p> <p>Advantage - \$2250 280A - \$1950 15m Byte - \$4499</p> <p style="text-align: center; color: red; font-weight: bold;">TELEVIDIO</p> <p>802 \$2520 802H - \$4450 806 - \$4950 800A - \$1250 803 - \$1890 1603 - \$2695</p> <p style="text-align: center; color: red; font-weight: bold;">APPLE-LOOK-A-LIKE CALL</p>	<p style="text-align: center; color: red; font-weight: bold;">OKIDATA</p> <p>M92A - \$ CALL M93A - \$ CALL M82A - \$ CALL/W/Tractor & Grap. \$ CALL M84P - \$ CALL M84S - \$ CALL Pacemark 2350P - \$ CALL</p> <p style="text-align: center; color: red; font-weight: bold;">CITOH</p> <p>F10 40 cps - \$1090 F10 55cps - \$1499 1550P - \$599 1550CD - \$655 8510P - \$375 8510BCD - \$499</p> <p style="text-align: center; color: red; font-weight: bold;">DATASOUTH</p> <p>DS120 - \$595 DS180 - \$1169</p> <p style="text-align: center; color: red; font-weight: bold;">DIABLO</p> <p>630RO - \$1725 620 - \$895</p> <p style="text-align: center; color: red; font-weight: bold;">NEC</p> <p>8023 - \$399 7710 - \$1999 3510 - \$1375 3550 - \$1750</p> <p style="text-align: center; color: red; font-weight: bold;">TRANSTAR</p> <p>140 - \$1290 130P - \$715</p>
APPLE CARDS	TERMINALS
<p>16K RAM - \$78 Z80 CARD - \$235 Videx Card - \$227 Viewmax-80 - \$175 Microsoft Prem. Pk - \$465</p>	<p style="text-align: center; color: red; font-weight: bold;">ADDS</p> <p>A1 - \$485 Viewpoint A3 - \$485</p> <p style="text-align: center; color: red; font-weight: bold;">HAZELTINE</p> <p>1500 - \$995 ESPRIT I - \$498</p> <p style="text-align: center; color: red; font-weight: bold;">TELEVIDIO</p> <p>910 - \$569 925 - \$718 970 - \$1040 950 - \$899</p> <p style="text-align: center; color: red; font-weight: bold;">ZENITH</p> <p>Z19 - \$670 Z89 - \$2129</p>
SOFTWARE	MONITORS
<p>All Major Brands 25% off List \$ CALL</p>	<p>Amdek 300 - \$130 Color I - \$295 Amdek Color II - \$425 Amber - \$145 BMC Green - \$85 USI Amber - \$149</p>
DISK DRIVE	COMPUTER IC'S COMPLETE LINE
<p>Microsci Apple Dr. - \$255 Rana Elite I - \$260 Rana Elite III - \$550 Rana 1000 - \$299</p>	<p>SPECIAL 4164 (150ns) \$5.50ea.</p>
MODEMS	
<p>HAYES - MICROMODEM - \$263 HAYES - SMARTMODEM - \$199 HAYES - 1200 Baud - \$499</p>	
DISKETTES/BOXES	
<p>Elephant - \$19 Scotch - \$25 Dysan - \$35</p>	
GUARANTEED LOW PRICES	Customer Service 602-863-0759

Sections 2 and 3 Seen as One Collection

Any operating system defines the interface that programmers must use

be replicated under CP/M, but there they are higher-level functions on an equal footing with any member of the standard library.

What Portions of the Standard Library Make Sense for CP/M?

Browsing through the available functions can help us to assemble a wish-list for CP/M. Naturally we can omit functions that deal with process management, such as fork() and wait() (described in chapter 17 of Volume 2). We can also dispense with functions—such as mknod(), for making new directories—that address incompatible aspects of the file systems. At the other extreme are functions whose suitability is clear, and we take these up before proceeding to the gray area between.

The I/O library: The standard I/O library is first on the list of things to include. (An exception, POPEN(3S), pertains to process communication and is therefore inapplicable.) Along with these subroutines, I am in favor of including the low-level functions

open(), creat(), lseek(), read(), write(), close(), and unlink(). This set is more convenient to use for byte-random access to binary files than are the buffered functions fread(), fwrite(), and fseek(); and, fopen(), unlike open(), does not provide access for both reading and writing at one time. Besides, unlink() is needed in any case.

The mathematics library: The mathematics library can, of course, be included. This consists of double-precision trigonometric, logarithmic, exponential, and hyperbolic functions as well as the less familiar Bessel functions. The function pow(x,y) is equivalent to exp(y*log(x)) and compensates for C's lack of the exponentiation operator that in FORTRAN allows writing simply x**y. Some lower-level functions are also convenient to have, such as frexp() and ldexp(), which provide separate access to the significand and exponent of doubles.

String and Character Handling

Many programmers who could live

without the mathematics library would not accept omission of the string functions, strcat(), strncpy(), index(), rindex(), and so on (see STRING(3)). Note that, as already indicated, some of the definitions do not agree with those given in K&R.

The character-classification macros —isalpha(), isupper(), and so on—are normally provided in the include file <ctype.h> (the angle brackets specify a standard directory in which include files are normally found). I find no mention of toupper() and tolower() in Volume 1, although they are included in the cited appendix of chapter 17, Volume 2 (and are, indeed, present in ctype.h). Actually, these functions are somewhat troublesome because their original formulation is, taking the first for illustration,

```
#define toupper(c) ((c) + 'A' - 'a')
```

which mutilates nonletters and must normally be preceded by the test

if (isalpha(c)) ...

TOLL-FREE (ORDERS ONLY) (800)392-7081

Calif., Alaska, Hawaii & all info call (213) 725-3080

PRICE, SERVICE, INTEGRITY...YOU OWE IT TO YOURSELF TO CALL US!



Star Gemini-10 100 CPS, 9x9 hi res. graphic, friction/tractor feed, 80 column. Parallel interface. SCALL Gemini 15 15" carriage. . . SCALL



BROTHER HR-1
Letter quality daisywheel printer 16 CPS, bi-directional, friction feed, parallel interface. Super value \$749
Serial interface . . . \$789
Tractor \$119



TRANSTAR 130P
Letter quality daisywheel printer. 16 CPS, bi-directional, proportional spacing, super/sub script, underline, bold face. 65dB quiet operation. Parallel \$699



5 1/4" DISK DRIVES
Tandon TM-100-1 SSDD 160K \$195
Tandon TM-100-2, DSDD 320K \$245
Tandon half height DSDD 320K \$255
Teac 56B half ht. DSDD 320K \$275
Panasonic half ht. DSDD 320K \$249



MONITOR SALE
BMC BM-AU8191MU 13" RGB color, 640-dot high resolution. Designed for IBM PC. Sale \$455



IBM PC & XT
IBM Personal Computers
Call for prices & configurations



COMREX CR-1
17 CPS daisywheel printer, bi-directional, Parallel. \$756
Serial Interface \$799
Tractor \$119



DYNAX DX-15
New! Letter quality daisywheel printer with 2-color printing. Logic seeking, bi-directional, proportional spacing, graphic & bold printing, direct printing, super/sub script, auto double strike & underline, 3 K buffer. Parallel. SCALL



DAISYWRI 2000
The intelligent letter-quality printer w/48K built-in buffer memory, 17 CPS, bi-directional, auto margin justification, universal interface \$1,195



Half Height Drives for Apple II
Super 6 (ALPS) 40-track, SS . \$239
Super 6 (Teac) 40-track, SS . \$269
Super 6 (Teac) double sided. . \$395
Control card for SS drive. . . \$59
Control card for DS drive . \$69



CORONA Computers
Complete with 128K memory, keyboard, hi-res monitor, graphics, serial & parallel interfaces, MS-DOS, GW Basic, PC Tutor, GSX Graphics, Speedsheet & Word Processing Software. Compatible w/most IBM PC hardware & software. CALL
Desk Model w/2-320K drives \$2,649
Portable Model w/2-320K dr. \$2,399



OKIDATA PRINTERS
ML-80P, 80 CPS, 80 col., friction & pin feed, block graphics, parallel interface. \$329
ML-82A, 120 CPS, 80 col., pin & friction feed, block graphics, serial & parallel interfaces. \$386
Okigrah-I 82A, 80x66 DPI dot addressable graphics for 82A . . \$45
ML-83A, 120 CPS, 136 col., tractor & friction feed, parallel/serial \$599
Okigrah-I 83A, 80x66 DPI dot addressable graphics for 83A . \$45
ML-84P, 200 CPS, 136 col., 9-pin head, dot addressable graphics, friction & tractor feed, parallel . \$959



JUKI 8100
NEW! Letter quality daisywheel printer. Features an 18 CPS speed, 10/12/15 pitches, 100-character daisywheel, 13" platen, a graphic mode & word processing functions. 2K buffer, 62dB quiet operation. It utilizes the popular IBM Selectric typewriter ribbons. Parallel. . \$699



AST Multi-Function Cards for IBM PC and XT
New Low Prices!
(Each card now comes w/ SuperDrive & SuperSpool) — ComboPlus Cards —
Amount of memory installed on card 64K 128K 192K 256K
with all options (serial, parallel ports & clock) — \$287 \$337 \$387 \$437



MegaPlus Cards
Amount of memory installed on card 64K 128K 192K 256K
w/standard features of serial port No. 1 & clock. \$289 \$339 \$389 \$439
w/ either parallel or additional serial port No. 2 - \$324 \$374 \$424 \$474
w/ both parallel and additional serial port No. 2 - \$368 \$409 \$459 \$509
MegaPak — expands a fully populated MegaPlus card to 812K \$336



FRANKLIN ACE 1200
Apple II and CP/M compatible, 128K RAM, built-in disk drive, controller, 80 col. card, serial & parallel ports, upper/lower case, numeric pad. CALL



OSBORNE Computers
Executive I — 128K RAM, 7" amber monitor, 2 serial & 1 parallel ports, 2 half height drives, plus Wordstar, Mailmerge, SuperCalc, Personal Pairs database, CP/M Plus 3.01. C-Basic and M-Basic softwares. CALL
OC-1 — Similar to above except 64K RAM, 5" green monitor, two full ht. drives and CP/M 2.2. CALL



C. Itoh ProWriter 8510AP, 120 CPS, 80 col., Graphics, Parallel . . . \$346
C. Itoh ProWriter-II 1550, 120 CPS, 136 col., 2K buffer, parallel. . . \$849
Cable-IBM to parallel printer- \$36



The new Epson FX-80 & RX-80 Call
Epson MX-80 and MX-100. CALL



I/O Plus Cards
Standard card w/one serial port (S1) and clock/calendar. \$129
with ONE additional option (RAM[G] or parallel[P] or serial [S2]) port \$168
with TWO additional options (GP, GS2, or PS2) \$199
with EIGHT additional options (IGP82) \$232



EASTERN ENTERPRISES, INC.
Miss Merchandising Since 1969
2937 S. VAIL AVE., LOS ANGELES, CALIF. 90040



In order, please send money order or cashier's check. Personal or company checks require 2-3 weeks to clear. Prices reflect 3% cash discount. Visa/Mastercard accepted. Shipping, insurance & handling charges are 3% of total order value by UPS Surface, 6% by UPS Air or Parcel Post. COD's require 20% deposit. Calif. residents add sales tax. No sales tax on out of state orders. Prices & availability subject to change without notice.

The **BROADEST LINE** of CPUs is also the **FASTEST.**

To get a job done *now*, you need **CompuPro** CPU boards. They not only run at maximum speed for maximum throughput, but like other **CompuPro** products, are designed to keep on running -- day in and day out -- to maintain peak system efficiency.

For 8 bit, 16 bit, or 8 *and* 16 bit operation, **CompuPro's** fine family of high speed CPUs deliver the performance, quality, and reliability you need for serious computing applications.

CPU 68K CPU 68K is the most advanced 68000 based board available. It includes sockets for an optional memory management unit and up to 8K X 16 (16 Kbytes) of EPROM. \$695 (8 MHz), \$850 CSC (10 MHz).

CPU 86/87 CPU 86/87 lets you take advantage of the 8086's large library of ultra-efficient 16 bit software. Includes sockets for 8087 math co-processor and 80130 firmware chips. \$750 ASM (8 MHz), \$850 CSC (10 MHz). Add \$300 for factory installed 8087 (limits clock speed to 5 MHz).

CPU 8085/88 CPU 8085/88 is the original, much imitated dual processor board. When you need the best of both worlds -- 8 bit, 16 bit, or 8 and 16 bit -- CPU 8085/88 delivers results in high-level computing applications. \$495 ASM, \$595 CSC.

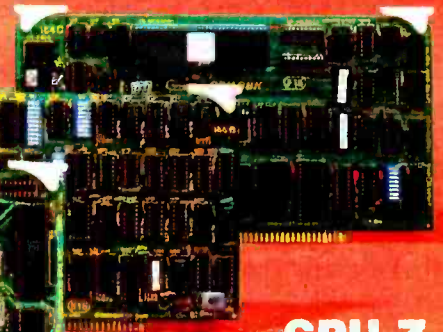
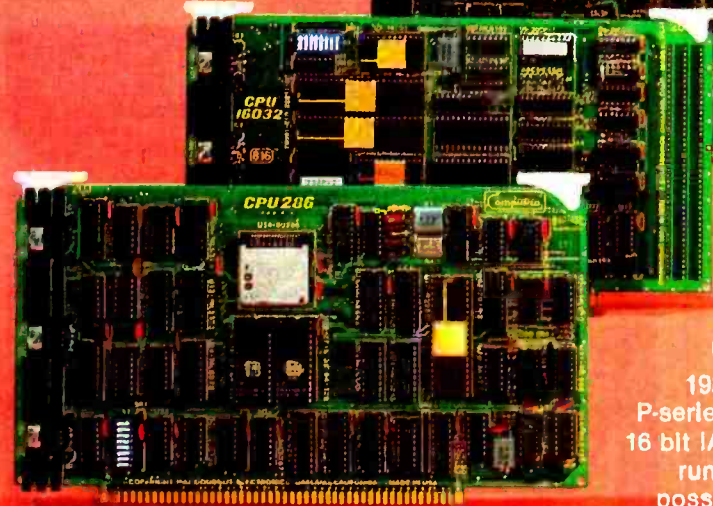

CPU Z

This premium 8 bit workhorse not only includes all standard Z80A features, but also has the necessary options to insure backward compatibility with most older S-100 mainframes. \$325, \$425 CSC.

CPU 16032 National's 16032 features *true 32 bit internal architecture* which more closely resembles that of a minicomputer than the architecture found in older micros; CPU 16032 lets you use this new processor to its maximum potential.

CPU 286 When we introduced CPU 8085/88 in 1980, we designed it to be upward compatible with future P-series processors. Three years later, CPU 286 (based on the 16 bit IAPX 286) not only protects your software investment by running all existing 8086/8088 software, but opens up new possibilities by combining an advanced instruction set with the use of four on-chip processors. \$1595 ASM, \$1750 CSC.

CompuPro CPU boards form the heart of our **System 816** family of high-speed, high-performance, modular computing systems. These include: **Model A** (CP/M® operating system, single user), **Model B** (CP/M, advanced single user), **Model C** (MP/M® 8-16™, multi-user), **Model 86/87** (MP/M-86™, multi-user), **Model 08** (Oasis operating system, 8-bit multi-user) and **Model 016** (Oasis, 16-bit multi-user).

CP/M is a registered trademark of Digital Research; MP/M and MPM-86 are trademarks of Digital Research. CompuPro is a registered trademark of CompuPro.

For business, scientific and industrial computing solutions, contact a **Full Service CompuPro Systems Center** or **CompuPro Sales Center** today; call **(415) 786-0909** for location.

CompuPro products are backed by a one year limited warranty (two years for boards qualified under the Certified System Component high-reliability program).



A **GODBOUT** COMPANY
3506 Breakwater Court, Hayward, CA 94545

Circle 85 on inquiry card.

A common, though questionable, practice is to alter the definition to incorporate the test:

```
#define toupper(c) ((c) >= 'a' && (c) <= 'z' ?
(c) + 'A' - 'a' : (c))
```

Of what I've seen, only the Code Works Q/C version 2.0 compiler retained the original toupper() and tolower() and added new functions chupper() and chlower(), which do the right thing.

Memory allocation, program exit: The memory-allocation functions—malloc(), free(), sbrk(), etc.—appear to be as natural under CP/M as under Unix. Most of the implementations I've seen are based on the one worked out at the end of K&R, chapter 8; they adopt the names alloc() and free() given there. Another easy transplant is the function exit(), along with its companion _exit(), which neglects to close all open files.

Program chaining: Several Unix system calls support program chaining; of these, execl() and execv() are

appropriate for CP/M. The format for execl() is

```
execl(name, arg0, arg1, . . . , argn, 0)
char *name, *arg0, *arg1, . . . , *argn;
```

Here name is the complete path name of an executable module; arg0 is a repetition of name as it would be typed from the default directory, and arg1 through argn are command-line arguments to be supplied to name. To quote a charming illustration (from chapter 17 of Volume 2),

```
execl("/bin/date", "date", NULL);
execl("/usr/bin/date", "date", NULL);
fprintf(stderr, "Someone stole 'date' \n");
```

If you don't know the number of command-line arguments in advance, the form

```
execv(name, argv)
char *name, *argv[ ];
```

may be used. (This is similar to the convention by which the function

main(argc, argv) is itself called.) Here argv is a null-terminated array of character strings; argv[0], argv[1], . . . is the same as arg0, arg1, . . . above.

The function execl() is adopted by BDS C and Supersoft C, but in an incompatible form. The term arg0 (admittedly superfluous under CP/M) is omitted, and the list begins with arg1 immediately following name. An alternative would be to replace the name execl() with another; for example, chain().

The Unix "system" function: Implementing the Unix library routine system(string), which causes the system to respond as if string were typed at the command level, is a real challenge. The difficulty is in making the program resume after the call completes. The effect is similar to that obtained using overlays, but the flexibility is greater because no special preparation is required for the called program. Supposing you can achieve this much, will addressing string directly to CP/M's Console Command Processor be satisfactory, or

**DEVELOPMENT HARDWARE/SOFTWARE
GTEK MODEL 7128 EPROM PROGRAMMER**



- Microprocessor based intelligence for ease of use and interface. You send the data, the 7128 takes care of the rest.
- RS-232 interface and ASCII data formats make the 7128 compatible with virtually any computer with an RS-232 serial interface port.
- Auto-select baud rate.
- Use with or without handshaking. Bidirectional Xon/Xoff supported. CTS/DTR supported.
- Devices supported as of DEC 82.

NMOS	NMOS	CMOS	EEPROM	MPU'S
2758	2508	27C16	5213	8748
2716	2516	27C32	5213H	8748H
2732	2532	C6716	X2816	8749
2732A	2564	27C64	48016	8741
2764	68766		I2816A	8742
27128	8755			8751
- Read pin compatible ROMS also.
- Automatic use of proper program voltage based on type selected.
- Menu driven eprom type selection, no personality modules required.
 - (40 pin devices require adapter)
- INTEL, Motorola and MCS-86, Hex formats. Split facility for 16 bit data-paths. Read, program, and formatted list commands also.
- Interrupt driven type ahead, program and verify real time while sending data.
- Program single byte, block, or whole eprom.
- Intelligent diagnostics discern between eprom which is bad and one which merely needs erasing.
- Verify erasure and compare commands.
- Busy light indicates when power is being applied to program socket.
- Complete with TEXTTOOL zero insertion force socket and integral 120 VAC power supply. (240 VAC/50HZ available also)
- High Performance/Cost ratio.
 - Model 7128 PRICE \$389.00 •••

MODEL 7128 SOCKET ADAPTERS
 MODEL 481 allows programming of 8748, 8749, 8741, 8742 single chip processors. Price \$98.00
 MODEL 511 allows programming the 8751, Intel's high powered single chip processor. Price \$174.00
 MODEL 755 allows programming the 8755 EPROM/IO chip Price \$135.00
 MODEL 7128/24 - budget version of the 7128. Supports 24 pin parts thru 32K only. Upgradable to full 7128 capacity. Price \$289.00

Non-expandable, very low cost models available for specific devices.
 MODEL 7128-L1 for 2716 only \$179.00
 MODEL 7128-L2 for 2732 only \$209.00

Also available from stock:
 EProm Erasers UVP model DE-4 . . . \$78.00
 Avocat Systems Cross Assemblers \$200.00
 RS-232 Cable Assemblies \$25.00
 Programmable Devices call
 Complete development systems . . . \$3240.00

Post Office Box 289
 Waveland, Mississippi 39576
 (601) 467-8048

GTEK INC.

ZX FORTH

for ZX81 and TS1000

Simplicity of BASIC with the speed of machine code!

A complete implementation of the FORTH language for the ZX81 and TS1000 computer. FORTH'S most distinctive feature is its flexibility. It can turn your computer into a "word processor". The basic unit is the WORD — the programmer uses existing WORDS to define his own which can then be used in further definitions. This makes program development much faster than other languages. FORTH is an interactive compiled language that expands the capabilities of your own ZX81/TS1000. Programs run up to 10 times faster than BASIC. The more programs you have written, the more words, therefore you can draw on those for further programs. FORTH is supplied on cassette and is accompanied by a 56 page users manual and an 8 page editors manual.
 (In Canada: \$39.95) **Z43 \$29.95**

NEW!
 Write for your FREE ZX81/TS1000 Catalog today!

Tiny Logo
 Teach your children programming skills through a computer graphics language. It's fun and easy too! **\$19.95**

Order toll free 1-800-833-8400
 N.Y. (716) 874-5510
 In Canada order toll free 1-800-268-3640
 Have your VISA or MASTERCARD ready!

GLADSTONE ELECTRONICS

1585 Kenmore Ave., Buffalo, N.Y. 14217
 In Canada: 1736 Avenue Rd., Toronto, Ont. M5M 3Y7
 Mail orders: VISA, MASTERCARD. Checks or money orders.
 No C.O.D.'s Add \$1.50 shipping.



PLATO EDUCATIONAL COURSEWARE BRINGS NEW EXCITEMENT TO LEARNING.

If your kids think serious education has to be dull, wait until they use Control Data PLATO® educational courseware.

With PLATO courseware, children can learn by competing against themselves; by interacting with stimulating graphics that keep them motivated. They see their progress, and find real excitement in achievement.

PLATO courseware is being used in classrooms across the nation. Now you can bring this quality education home. You'll find PLATO lessons at selected retail outlets where quality software is sold.

For the Apple II Plus and Apple IIe, the TI 99/4A or Atari 800.

The selection includes elementary Math lessons in Basic Number Facts, Whole Numbers, Decimals and Fractions.

Through such computerized activities as "darts" and "pinball," PLATO makes learning math almost fun.

Foreign Language lessons use the popular hangman or pyramid game concept to help teach French, German or Spanish in a way that holds and builds interest.

Our Computer Literacy lesson provides a perfect introduction to the computer age for kids and novices.

For Apple II Plus and Apple IIe.

Our Keyboarding lesson shows children and adults how to use a keyboard to enter data into the computer. Developed in cooperation with Gregg-McGraw Hill.

Widen your child's world.

See the growing library of PLATO educational courseware at selected retail outlets. Or for information and a free PLATO educational courseware catalog, call toll-free 800/233-3784. Or write: Control Data Publishing Co., P.O. Box 261127, San Diego, CA 92126. In California call 800/233-3785.

Warranty available free from Control Data Publishing Co., 4455 Eastgate Mall, San Diego, CA 92121



PLATO
COMPUTER-BASED EDUCATION

GD
CONTROL DATA
PUBLISHING

Circle 111 on inquiry card.



Some people drive fine German machines to work. Some people drive them once they arrive.

The tradition of high quality, high performance German craftsmanship and engineering is legend. And while we most often see that tradition in action on America's streets and highways, it is in America's business offices that its future holds the most promise.

The BASIS 108 is the proof.

This powerful small business computer passes higher-priced competitors with ease. Its dual processors — for CP/M® and Apple II® compatibility — open up the largest library of microcomputer software and plug-in peripherals available today.

This unique combination also provides compatibility with other popular languages, including Pascal™ and LOGO™.

The detached keyboard is a work of art and practicality. Lightweight and low profile, it features a full one-meter cord for comfortable operation on your desk — or your lap. There's a full 128-key ASCII character set. Fifteen user-definable function keys that can provide access to 60 distinct functions. A nine-key cursor control block. And a convenient eighteen-key numeric pad. For special applications, you can also custom map the keyboard with a simple exchange of ROMs.

And there's more. RGB and composite NTSC or PAL video. Keyboard-selectable 80- or 40-column display.

High resolution color graphics. Parallel and serial printer interfaces. Easily accessible onboard I/O connectors. Six Apple II-compatible card slots for peripherals expansion. Even a two-inch alarm or music speaker.

The BASIS chassis is cast aluminum, eliminating heat and RFI interference problems. And there's plenty of room for internal expansion to include hard disk drives and other peripherals.

The BASIS 108. Microcomputing's "Best Of Both Worlds." German craftsmanship and American business savvy. CP/M-based business computing and Apple II-based personal computing. High performance and surprisingly low cost. The BASIS 108. A computing machine finely tuned to handle the fast tracks of business today. Call your BASIS dealer for a test drive. Or call toll free in the U.S. (800) 222-0626.



BASIS
INCORPORATED

5435 Scotts Valley Drive
Scotts Valley, CA 95066
(408) 438-5804 TWX: 910-598-4512



CP/M® is a registered trademark of Digital Research, Inc. Apple II® is a registered trademark of Apple Computer, Inc. Pascal™ is a trademark of the Regents of the University of California at San Diego. LOGO™ is a trademark of Logo Computer Systems, Inc.

Circle 44 on Inquiry card.

www.americanradiohistory.com

would an intervening interpreter with sophistication approaching that of the Unix shell be preferable?

Some powerful utilities: There are some Unix utilities that are worthy of reproduction. The generic sorter `qsort()` and the random-integer generator `rand()` are examples that belong in this category and will be familiar to BDS C users. More ambitious efforts are required to duplicate the routines supporting arbitrary-precision integer arithmetic (see `MP(3X)`), database management (`DBM(3X)`), or encryption (`CRYPT(3)`). They'd certainly be nice to have.

It is useful to have a uniform and portable means for reading a real-time clock.

System clock: Many CP/M users employ a real-time clock (not, alas, for time-stamping files). It would be useful to have a uniform and portable means of reading such a device; the Unix approach provides a reasonable model. There are the system calls `stime()` and `time()` for setting and reading the clock; `time(0)` returns a long int equal to the elapsed seconds since 00:00:00 GMT (Greenwich Mean Time) January 1, 1970. Unix also provides a set of library routines for converting this to more familiar formats; for example, if `t` is the value returned by `time(0)`, then `gmtime(&t)` returns a pointer to a structure that looks like this:

```
struct tm {
    int tm_sec; /* 24-hour clock */
    int tm_min;
    int tm_hour;
    int tm_mday; /* day of month, 1 to 31 */
    int tm_mon; /* month of year, 0 to 11 */
    int tm_year; /* year - 1900, e.g. 83 for
                 1983 */
    int tm_wday; /* day of week, Sun=0,
                 Mon=1,... */
    int tm_yday; /* day of year, 0 to 365 */
    int tm_isdst; /* if !=0, daylight savings
                 time in effect */
}
```

Save time.

One call to the ITM experts gets you the right software at the right price ... in less than 20 minutes.

Expertise and low prices are just two reasons you should call ITM first.

For complete information and the 8 other reasons call toll free today.

We make software buying simple.

800-334-3404

IN CALIFORNIA CALL

415-284-7540

ITM™

936 Dewing Ave., Suite E
Lafayette, CA 94549

BHAT

YOUR ASSURANCE

"The Portable Office"



FREE
\$4,000 Worth
of Software

COLUMBIA VP Portable Computer

Fully compatible with IBM-PC: 128K ROM standard, 8088 CPU, socket for 8087 numeric processor. 2 Floppies 640 KB, serial & parallel ports, DMA, 1 IBM-PC compatible expansion slot. Keyboard, 9" screen w/full graphics built-in. AND, **\$4,000 WORTH SOFTWARE INCLUDED FREE:** MS-DOS, CP/M-86, BASICA, MS-BASIC, Perfect Writer, Perfect Speller, Perfect Filer, Perfect Calc, Fast Graphs, Home Accountant Plus, Macro Assembler, Asynchronous Communications Support, Columbia Tutor, Diagnostics Package, and Space Commanders!

Nationwide Service (BELL & HOWELL)

Whether you need a portable computer or not, this package represents OUTSTANDING VALUE for LIST \$2,999 **\$ CALL**

PIED PIPER Portable Computer

First truly portable computer which comes with a built-in quad-density Floppy (1 MB unformatted, 5 1/4"), 64K RAM, full-size keyboard, includes CP/M, PerfectWriter, PerfectSpeller, PerfectCalc and PerfectFiler. Serial & parallel outputs. No monitor, but can use external monitor OR connect to your own TV (RF modulator built-in) or use optional built-in modem (300 Baud auto-dial/answer). WEIGHS ONLY 12.5 lb, and small enough to carry daily from your home to the office (4"x20"x11") LIST ... \$1,296 **\$ CALL**

RITEMAN Dot-Matrix Printer

Small enough to fit in your briefcase (2 7/8"x14"x10 9/16", 11 lb.), yet prints 80/132 col. AND full dot graphics (9 x 9 printhead) at 120 CPS on standard, untreated paper! Adjustable tractor and friction feed standard. Emphasized characters, double-strike, italics, superscript & subscript, continuous underline and, of course, compressed /expanded characters. 1 line buffer, parallel interface standard, serial optional. LIST ... \$499



\$ CALL

SPECIAL INTRODUCTORY OFFER!

Buy a Columbia VP portable computer at list, and get a RITEMAN printer for only \$1.00 more!

FULL COLOR GRAPHICS \$1,999

- ABC terminal with full vector & char. graphics IN 8 COLORS!
 - Morrow Micro-Decision processor, 1 Floppy, CP/M
 - Nation-wide service
- Software package: PILOT CP/M Overlay for novice ease-of-use, WordStar, Logo-Calc, BASIC, GRAPHICS module ... add \$395
Second Floppy and Data Base program: add \$399
Double-sided Floppies add \$699
Morrow Micro-Decision w/o color terminal **\$ CALL**



FREE SOFTWARE CONSULTATION

Simply call (714) 783-3234. To place an order, call our toll-free line (800) 845-5555. If we don't have it, we'll tell you where to get it! Either way, you win!

IBM PC (MS-DOS)		Your Price	Word Processors:	
ATI Power for PC DOS	75	54	Wordstar (reg. CP/M)	495
ATI Power (WordStar)	75	54	Spellstar	295
Supercalc	75	54	Mailmerge	295
MBASIC	75	54	Super Sort	195
Multiplan	75	54	BONUS PACK	990
Visicalc	75	54	(Includes: Wordstar & M/merge)	455
dB Power	75	54	Word Handler	199
EasyFiler	75	54	CP/M (Most Formats)	139
EasyWriter II	75	54	CP+	150
Versa Form	389	288	Random House Thes.	150
BSTAM	200	144	dPATCH	195
Target Fin. Model	325	253	MicroLib File Lib.	295
Condor I Database	295	212	ATI-Pwr. for CP/M	75
Condor III Database	650	488	dB POWER	75
Home Account. Plus	150	104	Wordstar Power	75
1st Class Mail	124	89	SuperCalc Power	75
Properly Management	495	345	MBASIC Power	75
Write on	129	89	MultiPlan Power	75
Real Estate Invest.	129	94	dBASE II	700
Random House Thes.	150	109	Financial Planner	700
Money Decisions	199	144	Bottom Line Strat.	400
ZORK I, II, III	39	29	BSTAM	200
Deadline	39	29	Cardbox	245
Star Cross	39	29	Roots/M	195
PC Text	100	70	PlannerCalc	99
Window	150	109	Target Fin. Modeling	325
Wordtrix	34	25	Palantir Word Proc.	425
Joysticks (Kraft Sys.)	69	49	FMS-80	995
Spellbinder	495	274	Citation card file	250
Mince	175	160	Supervyz	150
Final Word	300	215	Micro B+ I/BASIC	260
Scribble	175	159	Micro B+ I/MBASIC/	260
Cross Talk	195	149	COBOL	
StatPack	495	359	Smart Key	60
The Word Plus	150	108	Smart Print	35
The Personal Investor	145	99	QuickScreen I/BASIC	149
RM/COBOL	950	684	MBASIC, dBASEII	123
RM/COBOL Runtime	250	179	FMS80	
Job Cost System	495	359	dGRAPH	295
File Manager Plus	149	109	dUTIL	99
Advanced Visicalc	400	309	Quickcode	295
VisiWord	375	293	Agri-bus. Software	3500
VisiSpell	225	176	Prof. Time Acct.	595
Visicalc	250	189	SuperFile	195
Desktop Plan	300	229	ZORK I, II, III	49
VisiDex	250	219	Deadline	59
VisiTrend/Plot	300	229	Star Cross	49
Bus. Forecast. Models	100	79	Mathemagic	99
Move-It	150	99	Pascal 7	450
Multiplan	275	219	Pascal BZ (bus. ver.)	450
			Spellbinder	495
			Final Word	300
			Benchmark	499
			Benchmark mailist	250
			CIS Cobol	850
			FORMS 2	200
			FORTH 79	139
			CROSSTALK	195
			ZIP (C or M-BASIC)	160
			ZIP for both C- and	225
			M-BASIC	142
			StatPack	495
			The Word Plus	150
			Textwriter III	125
			Datebook	295
			Milestone	295
			Job Files (Proj. Cost)	500
			Pearl 1	49
			Pearl 2	295
			Pearl 3	495
			Personal Pearl	295
			The Oquad	495
			Quick 'N Easy Pro	395
			MailMan	125
			Quick 'N Easy Gen.	295
			CRF FORM	400
			Encode/Decode	100
			Diagnostic II	125
			Term II	200
			Disk Doctor	100
			Disk Edit	100
			Scratch Pad	295
			Move-It	125
				94

of the BEST DOLLAR VALUE

SPECIALS OF THE MONTH!



SMITH-CORONA

TP-1
AT OUR PRICE,
NO COMPUTER
SHOULD BE
WITHOUT ONE!

Daisy-wheel, letter-quality, interfaces all computers. Serial & parallel models at same low price. No less than 18 print-wheels—only \$6.95 each, List \$8.49. ONLY \$5.45!

NEW: Tractor for TP-1, easy retro-fit \$129



GEMINI-10
from
Star-Microtronics

All the features of EPSON-FIT, plus backspace, continuous underline. List \$499..... ONLY \$ CALL!!!

**Special: New prices
TOO LOW TO ADVERTISE!**

GEMINI-15 similar but 15" carriage. Even better buy! List \$649..... ONLY \$ CALL!!!

TRANSTAR COLOR PRINTER SCALL

Mannesmann-Tally MT-160L

No other printer can match all these features: serial AND parallel inputs standard, 160 cps standard, dot graphics standard, front-panel programming standard, heavy-duty construction. **TRACTOR INCLUDED** \$ CALL!!!

MT 160 L: all features of MT-160L plus LETTER-QUALITY printing at 50 cps. \$ CALL!!!

Exceptional buy



IBM-PC COMPATIBLE COMPUTERS

ZENITH Z-100

NEW LOW PRICES!

Advanced color graphics, 16/8 bit, 128K RAM, 11 MByte Hard Disk. List \$5495..... \$ CALL

IBM-PC 64K
two floppies 320K
color board \$CALL

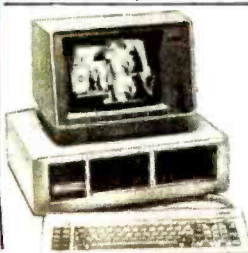

EAGLE



EAGLE-PC—Fully IBM-Compatible. Detached keyboard, 105 keys, 24 user-defined. EAGLE-PC—1 floppy - List \$1995..... \$ CALL

EAGLE-1600—Uses 8086, faster than IBM-PC \$CALL

COLUMBIA



COLUMBIA 1600 accepts all IBM boards, reads all IBM software, 128K, 8 expansion slots! NEW: \$3,000. FREE SOFTWARE: \$CALL

CORONA PC

The quality you expect from Corona — at a price you can afford! 128K RAM standard, 2 Floppies (320 KB each) or 1 Floppy and 10 MB internal hard disk, 4 expansion slots, 83-key keyboard, serial & parallel ports. High-resolution graphics standard (640x325 pixels)! Both MS-DOS and CP/M 86 included. GW-BASIC, GSX graphics software and word processor standard. LIST \$2,999..... \$CALL

BUY OF THE MONTH

EAGLE II 64K RAM, superb display, dedicated Word Processing keys, Spell-Binder, Ultra-Calc, CBASIC, CP/M, 1 Floppy 390KByte

LIST \$2,999... \$ CALL

EAGLE 10 MByte Hard Disk List \$2495..... \$ CALL for SPECIAL PACKAGE DEAL

1 Full Year Warranty,
Nationwide service (Bell & Howell)

SPECIAL OFFER:
Buy an Eagle II at the new, reduced price and get a Gemini 10 printer for only \$1.00 additional!

3M FLOPPY DISKETTES

Best Prices in the World

SOFTWARE SPECIAL SELECTOR V 2nd GENERATION DATA-BASE

More Powerful More Flexible

- Built-in capability to extract information from up to 6 Data-files simultaneously to generate a single report!
- Full-Screen Editor integral, allowing free creation of Data. Entry Screens with no additional software! (No need for Quickcode or similar software).
- LOWER PRICED: List \$900. Only \$649 (Compare with DBase plus Quickcode).

SPECIAL OFFER: Selector V Demo, Handles 60 Records with Full Capabilities and Full Documentation

ONLY \$1 Per Record (\$60)



NEW: JUKI 6100

Letter quality daisy wheel printer, all word processing functions/graphics, 18 CPS. List \$699..... \$CALL

TELEVIDEO
KEYPRO
ZORBA
\$CALL

NEC P-8800

Personal Computer System: Just Arrived:

All the flexibility one could ask for, in highest performance system! 2-80 standard, 8086 16-bit processor optional, ROM Basic (8/16 bit), Graphic RAM, 5 1/4 and 8" floppies. Include 3 individually-controlled windows, text & graphics, RGB or composite display, cassette interface. LIMITED SUPPLY \$CALL

Displayed and sold at our Showroom,
12210 Michigan Ave., Grand Terrace, CA:

MICRO-DECISION by Morrow Designs

Perfect desk-top computer:

• 2-80, 1 Floppy standard, 2nd optional. Optional terminal, or use your own. • CP/M with user friendly "shell". • WordStar, SpellChecker, SpreadSheet, Microsoft Basic-80 & BASIC. List \$1195 to \$1790, Limited Quantity CALL For Availability.

NEW: Now with double-sided double-density Floppies (800 KB storage), and with Data Base Management Software..... CALL For Availability!

NEC APC

Extremely sophisticated graphics and color display (1024x1024 pixel) 16-bit (8086), 128K standard, expandable to 256K, 1-2 8" Floppies 1 MEG each (run any CP/M program available on 8"). Detachable keyboard. Integral monitor (monochrome/color). Extensive software.

H01 Monochrome, 1 Floppy List \$3298
H02 Monochrome, 2 Floppies List \$3998
H03 Color monitor, 2 Floppies List \$4998

CALL for appointment

NEW Brother HR-15 Letter Quality Printer

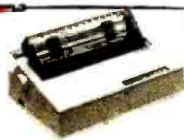

TAXAN COLOR MONITOR..... \$CALL
AMDEK 12" Amber \$159
AMDEK COLOR III RGB \$382
Zenith RGB hi-resolution RGB \$524
PGS hi-res. 12" RGB \$645
NEC 12" RGB hi-res..... \$CALL

INTERFACES & MODEMS, ETC.

Hayes Modems \$CALL
MICROFAZER printer buffer \$139
ALL QUADRAM BOARDS \$CALL
TYMARC printer-adapter /APPLE ... \$89
GRAPPLER \$129

DOT-MATRIX PRINTERS:

Okidata 83A 132 col. (s/P) \$649
Okidata 84-P 200 cps. & 50 cps \$994
Okidata 92, just released \$CALL
NEW: Cut Sheet Feeder for Okidata 84 \$CALL
IOS Microprism: serial and parallel inputs, two printing speeds and printing grades: Draft/Correspondence... \$519

Letter-Quality Printers:

Fujitsu 80 CPS (!) \$2289
NEC 3510 33cps serial \$1449
DIABLO 620 25cps. ser. \$1094
DaisyWriter 200, 48K buffer, \$1023
TRANSTAR, emulates Diablo, parallel \$699
TOSHIBA 1350, heavy-duty, .. \$1649
QUME NEW SPRINT II 40 cps. LIST \$1681 \$CALL
OLYMPIA ES100KR0 Electronic Typewriter/Printer 17.5 CPS: s/p \$1150

NEW COD 15 Day Exchange Privilege (subject to terms below)

Mo-Fri 7:00 AM-5:30 PM PST, Sat. 12:00 Noon-5:00 PM PST

1-(800) 845-5555 CA, AK, HI call (714) 832-3443 TELEX 472-0127 ATTN: EMD

BANK REFERENCE: BARCLAYS BANK OF CALIFORNIA (213) 892-7244



AMERICAN EXPRESS, VISA, MASTERCARD
APD FPO INTERNATIONAL ORDERS ACCEPTED



INC. P.O. Box 3791, Riverside, CA 92519

TERMS: Price in the ad apply to prepaid orders only, reflect 5% cash discount off our regular sale prices. Personal checks allow 2 week to clear. Fortune 1000 companies, Universities and Government only. 30-day net based on our regular terms, cash prices, COD based on non-cash prices and requires payment in full by Cashier's Check or Certified Check upon delivery. California residents add 6% tax. Third ad supersedes all prior offers. Prices subject to change and effect may be withdrawn without prior notice. All merchandise new in original factory cartons, carry full manufacturer's warranty, and are covered by full insurance during shipping. Absolutely no return on used or damaged items. Software refundable ONLY in UNOPENED original wrapping. We now offer 15 DAY EXCHANGE PRIVILEGE, subject to 10% restocking charge on returned merchandise, and excluding special order items. Add 3% for handling, shipping & insurance (\$3.95 minimum).

APPLE is trademark of Apple Computer Inc. IBM is trademark of International Business Machines Inc.

localtime(&t) returns a pointer to a structure of the same kind, but with local time instead of GMT. Finally, the function asctime() accepts a pointer to a tm structure and returns a string of the form

```
Wed Apr 13 21:13:30 1983 \n \0
```

It would also be nice to have available the date command (described in section 1 of Volume 1), which elicits a string in this format; or which, if typed with an argument, is used to set the system clock, as in

```
date 8304132113.30
```

which sets the date shown above. Users who do not already own a real-time clock may find time() and stime() convenient primitives, for a count of seconds can be maintained using simple hardware (or no new hardware at all, if interrupts are available). Owners of real-time clocks might prefer that localtime() had been the primitive function because it seems silly to have to implement time() by reading a date that is then converted to seconds since 1/1/1970, only to hand this back to localtime() to get the date again. However, the conversion to seconds is no big deal, and the transformation is a useful one to make in any case. Many interesting problems, from appointment sched-

uling to keeping track of the planets, involve computing the duration between two points in time; this is a far more natural operation when those points are represented as elapsed seconds from a common epoch than when they are encoded in the asctime() type format that is admittedly more suitable for display.

Difficulties Acknowledged

Functions like sin() or strcat() are clearly indifferent to the operating system under which they are invoked; translation from Unix to CP/M will be an issue only for functions that call on the Unix system interface. As I stated earlier, system calls that deal with concurrent processes, or that depend too intimately on the structure of the file system, will be inappropriate for CP/M. The difficult ground occurs with Unix functions for which an analogous, but not identical, service makes sense for CP/M. For example, chdir() changes the default directory under Unix and could be used under CP/M to log a different drive or user number. Likewise, the Unix system calls access() and stat() retrieve information about a named file and could be mapped into CP/M lookalikes. The appropriateness of doing this is partly a subjective matter; you may feel comfortable with the identification, or the analogy may seem strained by

the attempt to ignore the underlying differences of the file systems. It is easy to state criteria for translation—the meaning of the function is preserved, and the result works well in the new environment. The hard part is judging that these conditions are met in specific cases.

An example of a bad translation might be instructive. The system call unlink(), which deletes a file from a directory, is entirely at home under CP/M, and I adopted it without hesitation. Suppose I want to do the same with its companion call link(oldname, newname), which creates a directory entry "newname" as a synonym for the already existing file "oldname". CP/M does not allow two names for the same file, but if I get rid of the old one, then I will have merely renamed the file. Should I coerce link() into performing the rename() function under CP/M? Clearly, no. The essential idea of linking has been destroyed along with the original file name. Common practice is to coin the new function rename(), as in BDS, Supersoft, or Aztec C.

Other Inheritances

Beyond the standard library, most of the CP/M C compilers support I/O redirection and the argc, argv convention for command-line arguments. The redirection itself is quite easy to achieve, but pipes are more trouble-

State-of-the-art Video Filter (for just \$19.85)

The Perfect Match: PANELGRAPHIC'S VIDEO FILTER AND YOUR TRS-80, IBM P.C., DEC VT 100

No other video filter clarifies your C.R.T. display like the Panelgraphic Video Filter. We designed it specifically for these terminals — not just in size, but in spectral output. Treated with a patented anti-glare coating, it makes a graphic improvement in the readability of your display: bold characters stand out on a professional green background uncluttered by reflection. What's more, this filter is easy to install with self-adhering tabs, and even easier to afford, with a price tag of just \$19.85, postage paid. At Panelgraphic, we've brought video filters into the computer age and up to the state of the art. Inquire about our custom-designed filters for other popular personal computers.



PANELGRAPHIC CORPORATION
10 Henderson Drive • West Caldwell, New Jersey 07006
Phone (201) 227-1500; TWX: 710-734-4367

We're better, and it shows.

TO ORDER, CALL 800-222-0618. IN NEW JERSEY, CALL 800-222-0617.
MASTERCARD, VISA, AMERICAN EXPRESS ACCEPTED.
ALLOW 2-3 WEEKS FOR DELIVERY. SPECIAL RATES AVAILABLE FOR LARGE ORDERS.
N.J. RESIDENTS MUST ADD 6% SALES TAX.



The ultimate printing machines.

Perfect business partners for IBM, Apple, Osborne, Eagle and other micros.



One machine solutions to every application. Prices starting at \$698.

Meet the leading family in multi-functional micro printers. The 80-column Tally MT 160 for a small footprint; the 132-column Tally MT 180 for accounting and spreadsheet packages. (Print at 20 cpi and get 264 columns!)

A Word Processing package gives you letter quality text, proportional spacing, margin justification, auto centering. A resident Graphics package offers the versatility of two different dot densities. And you get high speed report printing at 160 cps

bi-directionally. Plus eight different resident character widths for condensed or double-wide printing.

There's more. 3-way paper handling lets you use fanfold forms, letterhead or roll stock. The control panel has a conversational program menu for easy "answer a question" push-button set-up. The dual interface has both a serial and parallel port for direct plug compatibility with your micro (no hidden interface costs!) And one look at the solid machine construction lets you

know that Tally builds printers to last!

Tally has the printers for today that you won't outgrow tomorrow.

Mannesmann Tally, 8301 S. 180th Street, Kent, Washington 98032. Phone (206) 251-5524. Mannesmann Tally Canada, 703 Petrolia Road, Downsview, Ontario M3J 2N6. Phone (416) 661-9783.

For the name of the sales outlet nearest you, call toll free **1-800-447-4700.**

(In Illinois 1-800-322-4400)

MANNESMANN TALLY

Computer printers manufactured in the U.S. and Europe for worldwide markets. Circle 246 on Inquiry card.

QUALITY

PERFORMANCE

SDSYSTEMS

RELIABILITY

The Choice of Systems Integrators Worldwide!

The features you need, the quality you demand, and field proven with over 50,000 S-100 boards sold since 1977. SDSystems quality board products now backed by a *one year warranty*.

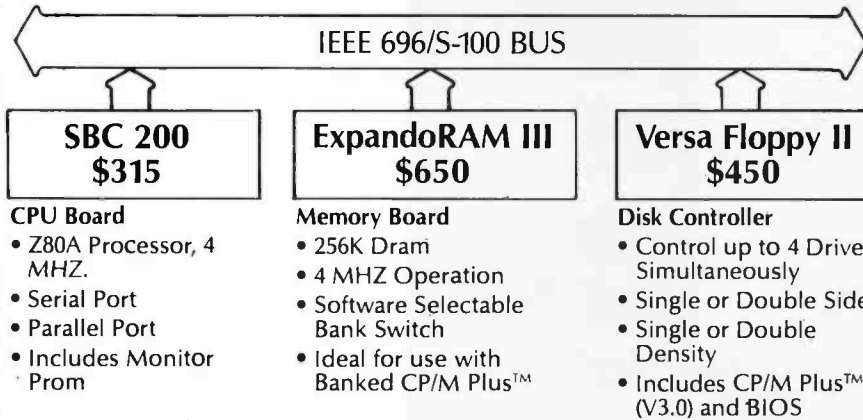

**Buy the Complete SDSystems
Three Board Set with CP/M Plus™
And SAVE**

**YOUR
COST**

\$1295⁰⁰

Price if Purchased Separately \$1415

SDSystems State-Of-The-Art S-100 Mainframe Enclosure

- 6 Slot Motherboard with folded bus architecture
- Power supply, reset, and on/off are integral to the motherboard
- Dual cooling fans
- Compact size approximately 4"X14"X17"

CP/M Plus™-High Performance Single User Operating System

- CP/M 2.2™ compatible-no modification
- When used with SDSystems 256K memory board speeds are up to 7 times faster than CP/M 2.2™
- Support for 1 to 16 banks of RAM
- High performance file system

Obtain These and Other Fine SDSystems Products From:

\$100

Div. of 696 Corp



Est. 1977

14425 North 79th Street, Suite B
 Scottsdale, Arizona 85260
 TELEX 165025
 Technical 602-991-7870
 Sales 800-528-3138

FULL DEALER SUPPORT

Visit our Showroom, Hours Monday-Friday 9:00 am-5:00 pm

CP/M 2.2 and CP/M Plus Trademarks of Digital Research, Inc.

some to implement, and only BDS C does it, so far as I'm aware. It's easiest to have each program run to completion and deposit its entire output in a temporary file, to be used as input by its successor. But a more foolproof way is to limit the output of individual programs—to avoid filling the disk—even though this adds the burden of round-robin management.

Command-line arguments are also easy to provide, except for the minor detail that CP/M refuses to let you do it! There's no legal way to capture, in argv[0], the name by which a program is invoked; thus, phrases like

```
if(argc==1) {
    printf("usage: %s filename \n", argv[0]);
    exit( );
}
```

cannot be used with CP/M. Much more annoying is CP/M's insistence on mapping its command line to uppercase; this makes it impossible to run a Unix C program in which the command-line switch -a has one meaning while -A has another.

Devices as files: One of the outstanding features of Unix is its uniform syntactical manner of addressing files and devices. Some of the C compilers, including Aztec C, support this to a limited extent: the names con:, lst:, rdr:, and pun: correspond to the logical CP/M devices so named. It is legal to open the listing device for output:

```
FILE *lst, *fopen( );
if((lst = fopen("lst:","w")) == NULL) {
    fprintf(stderr,"cannot open lst: device \n");
    exit( );
}
```

Then you can send formatted output to the printer:

```
fprintf(lst, "The square of %d is %d \n", i, i*i);
```

What is really wanted is the ability to incorporate arbitrary new devices into the file system; by writing a set of drivers and associating them with a name, I should be able to "open" the named device, read from it, and write to it using standard library functions. Further, writing the

THE BEST KEPT SECRET IS OUT....

JUKI LETTER QUALITY, DAISY WHEEL PRINTERS ARE NOW AVAILABLE NATIONWIDE AT \$699⁰⁰



There's no mystery about it! Juki's Model 6100 bi-directional, daisy wheel printers are full featured and priced right!

Designed to perform word processing and graphic functions including bold face, subscript, superscript and shadow, the Model 6100 prints at 18 cps, has a proportional spacing control and utilizes 100 character drop-in daisy wheels. The Juki printer uses IBM Selectric Ribbons and is compatible to IBM, Apple, Osborne, Kaypro and most other personal computers. But that's no secret!

The news is that the Juki Model 6100 printers are now available through a reliable network of industry professionals strategically located throughout the country to give you the prompt, dependable sales and technical service you need. And Juki distributors are backed by a company who has been specializing in electronics for over 25 years.

So, contact the Juki distributor nearest you for the real undercover story on the best letter quality, daisy wheel printer around.



CONTACT YOUR JUKI DISTRIBUTOR FOR THE DEALER LOCATION MOST CONVENIENT FOR YOU:

ACORN DATA PRODUCTS 7304-L South Alton Way Englewood, CO 80112 303/779-6644 Serving: MT, WY, CO, UT, NM	BUTLER ASSOCIATES, INC. 82A Winchester Street Newton, MA 02161 617/964-5270 Serving: ME, NH, VT, CT, RI, MA	COMPUTER SERVICES INTERNATIONAL CORP. 905 Boulevard East Weehawken, NJ 07087 201/866-2880 Serving: METRO NY, E. PA, NJ	GENTRY ASSOCIATES, INC. 7665 Currency Drive Orlando, FL 32809 305/859-7450 Serving: TN, NC, SC, MS, LA, AL, GA, FL	INFORMATION SYSTEMS, INC. 2420 E. Dakton Street, Unit K Arlington Heights, IL 60005 312/228-5480 Serving: WI, IL, MN, IA, MO, NE, ND, KS, SD	INTERNATIONAL BUSINESS SYSTEMS CENTER 7023 Little River Turnpike Annandale, VA 22003 703/750-3882 Serving: MD, DE, DC, VA	OSSMANN COMPUTER TECHNOLOGIES, INC. 6666 Old Collamer Road E. Syracuse, NY 13057 315/437-6666 Serving: UPSTATE NY	SIGMA DISTRIBUTING 2110 116th Ave. N.E. Bellevue, WA 98005 206/454-6307 Serving: WA, OR, ID, AK
SOUTHERN MICRO DISTRIBUTORS 8708 Royal Lane Irving, TX 75063 214/258-6636 Serving: TX, OK, AR, LA	STAR-TRONIC DISTRIBUTOR CO. 23976 Freeway Park Drive Farmington Hills, MI 48024 313/477-7586 Serving: MI, IN, OH, KY, PA, W. PA, WV	TECHNOLOGY MARKETING CORP. 2300 Valley View Lane Suite 109 Dallas, TX 75234 214/243-7994 Serving: TX, OK, AR, LA	VITEK 930-G Boardwalk Avenue San Marcos, CA 92069 619/744-8305 Serving: S. CA	WESTERN MICRO TECHNOLOGY 10040 Bubb Road Cupertino, CA 95014 408/725-1660 Serving: N. CA, NV, AZ	NATIONAL HEADQUARTERS: JUKI INDUSTRIES OF AMERICA, INC. OA DIVISION 299 Market Street Saddle Brook, NJ 07662 201/368-3666	WEST COAST JUKI INDUSTRIES OF AMERICA, INC. CALIFORNIA DIVISION 20437 South Western Avenue Torrance, CA 90501 213/320-9001	

drivers should be sufficient; I should not be required to recompile the standard library.

This could be achieved in the following way: a standard source file, `devices.c`, could be used to house all device drivers, these being, for each device, the appropriate "flavor" of `open()`, `close()`, `read()`, `write()`, and `lseek()`. The compiled form, `devices.o`, would be available on the disk for linking.

We might find, in `devices.c`, a structure such as the following:

```
struct dev {
    char *name; /* device name */
    int (*open)(); /* open function */
    int (*close)(); /* close function */
    int (*read)(); /* read function */
    int (*write)(); /* write function */
    long (*lseek)(); /* lseek function */
} dev[] = {
    {"plotter",pl_open,noper,pl_read,
    pl_write,noper},
    ...
    {NULL,NULL,NULL,NULL,NULL,NULL}
    /* mandatory last entry */
};
```

The function names `pl_open`, . . . would be declared ahead of the structure definition. A null function, `noper()`, simply returns 0 when called.

The standard library function `open()` must be written so that a given name that is neither a file name nor a CP/M device name (e.g., `con:`) can be associated with an external device. If the name corresponds to entry `n` in the device array `dev[]`, the file descriptor returned by `open()` is `n+MAXFD`, where `MAXFD` is the number of file descriptors reserved for files and the CP/M devices. The search loop might appear:

```
for (i=0; dev[i].name != NULL; i++)
    if (strcmp(name, dev[i].name) == 0)
        return (i+MAXFD);
return (-1);
```

The other standard library functions, such as `read()`, must know how to use this file descriptor:

```
read(fd, buf, n)
int fd, n;
char *buf;
{
    ...
    if (fd >= MAXFD)
        return (*dev[fd - MAXFD].read)(fd, buf, n);
    ...
}
```

Restrictions Inherent in CP/M

Beyond CP/M's mapping of command-line arguments to uppercase and its refusal to turn over the program name to `argv[0]`, some other problems are hard to get around. Perhaps the most vexing of these is that CP/M denotes the end of a line of text by a carriage return followed by a linefeed. Unix employs just the linefeed. The problem has its origin in the teletypewriter code: the carriage return and the linefeed corresponded to physical actions on the teletypewriter; a separate newline code should denote the beginning of a new line. As it stands, both CP/M and Unix behave reasonably.

I suspect that implementers must agonize over how to handle this situation. For simplicity, consider output only: we might want to arrange for `putc()` to write a carriage-

Finally, the reason to buy a computer

EXCEL

Software to be released in the U. S. December 1983
through selected, supportive Distributors.

True MAIL ORDER Prices

With so many so-called Mail Order establishments using "toll free" lines, and grandiose advertising, how can you, the customer, expect to receive true mail order savings? We have done away with these expenses to offer comparable service passing on the savings to you. Our reputation for low prices and satisfaction is outstanding.

DISKETTES	PRINTERS	MONITORS
Kangaroo: (w/library case) 5 1/4" SS/DD \$21.35 5 1/4" DS/DD \$28.95 Now available: The 6-pak 5 1/4" SS/DD \$14.45 5 1/4" DS/DD \$19.45 — 10 yr. Warranty — Elephant: 5 1/4" SS/DD \$21.95 5 1/4" DS/DD \$28.95 Verbatim: 5 1/4" SS/DD \$22.95 5 1/4" DS/DD \$38.95 Dysan: 5 1/4" SS/DD \$29.95 5 1/4" DS/DD \$38.95 Library Case 5 1/4" \$ 1.75	Okidata: Microline 92 \$ 499.00 Microline 93 \$ 869.00 Pacemark 2350: Parallel \$1999.00 Serial \$2099.00 Pacemark 2410: Parallel \$2299.00 Serial \$2399.00 Call for prices on the entire line of Okidata Printers. Call for the New Epson FX Printers,	Amdek: Color I \$295.00 Color II \$489.00 300G Green \$145.00 310G Green \$175.00 310A Amber \$175.00 Zenith: 12" Green. \$ 99.00 USI: 12" Amber \$159.00 12" Green \$155.00 *Taxan: Amber \$139.00 PGS: RGB Monitor \$ CALL BMC: 12" Green \$ 85.00 NEC 1203 Hi Res RGB \$589.00
MODEMS Hayes: MicroModem II with Terminal Program \$285.00 without Terminal Program \$255.00 Hayes Smartmodem: 300 Baud \$199.00 1200 Baud \$505.00 Hayes Chronograph \$179.00 Novation: J-Cat \$104.00 Appletalk II \$285.00 Smartcat 1200 Baud \$440.00 U.S. Robotics: 300 Baud \$165.00 1200 Baud \$459.00	C.I.TOH: Prowriter I Parallel \$ 369.00 Prowriter II Parallel \$ 629.00 F-10 Starwriter \$1150.00 F-10 Printmaster \$CALL Brother HRI: \$ 775.00 Smith Corona TPI: \$ 539.00 Star Micronics: NEW Gemini 10X Call for low prices!	DISK DRIVES For Apple: Fourth Dimension: w/o controller \$219.00 w/ controller \$309.00 Rana Elite I: w/o controller \$270.00 w/ controller \$339.00 For IBM: Shugart Half-Height \$239.00
COMPUTER PRODUCTS FOR IBM The Ultimate Peripheral MONTE CARLO™ GT™ CARD 64K \$CALL \$45 per 64K upgrade Ask about the Quatro™ Card T & G Products: Joysticks \$42.00 Trakball \$49.00 BUSINESS Vislcorp: Visidex \$180.00 Visifiles \$180.00 256K Visicalc \$180.00 Visitrend/Plot \$225.00 ENTERTAINMENT: Infocom: Zork I \$27.00 Zork II \$27.00 Zork III \$27.00	NEW PRODUCTS Commodore 64 \$CALL Commodore Disk Drive \$CALL Panasonic JR200 \$299.00 Percom Hard Disk Drives: (Apple/IBM TRS-80) 5, 10, 15 and 20 MB \$CALL Juki Printer: • LQ • 18CPS \$CALL	COMPUTER PRODUCTS FOR APPLE MBI: VIP Graphics Card \$109.00 Appletime Clock Card \$ 75.00 Silicon Valley Systems: Final Analysis \$149.00 Word Handler \$115.00 Continental: Home Acct. \$ 49.00 On-Line: Screenwriter II Pro \$139.00 Vislcorp: Visidex \$180.00 Visifiles \$180.00 Visicalc \$180.00 Visitrend/Plot \$225.00 Stoneware: DB Master \$149.00 DB Utility Pak \$ 65.00 T & G Products: Joysticks \$42.00 Select-a-Port \$42.00 Game Paddles \$28.00 Davong Hard Disks 5 Megabytes \$1359.00 10 Megabytes \$1759.00 15 Megabytes \$2159.00 Ram Cards Microsoft 16K \$75.00 Generic 16K \$60.00 Microsoft CP/M Z80 Card \$249.00 80 Column Card: Videx w/software \$269.00
COMPUTER PRODUCTS FOR IBM The Ultimate Peripheral MONTE CARLO™ GT™ CARD 64K \$CALL \$45 per 64K upgrade Ask about the Quatro™ Card T & G Products: Joysticks \$42.00 Trakball \$49.00 BUSINESS Vislcorp: Visidex \$180.00 Visifiles \$180.00 256K Visicalc \$180.00 Visitrend/Plot \$225.00 ENTERTAINMENT: Infocom: Zork I \$27.00 Zork II \$27.00 Zork III \$27.00	TANDON DISK DRIVE SPECIAL TM-100-2 DS/DD 320K Bytes \$245.00 TM-55 320K Bytes Half Height \$239.00 QuadRam Quadboard 64K \$285.00 128K \$330.00 192K \$375.00 256K \$415.00 Kraft Products: Joysticks \$55.00 Game Paddle \$29.00 Davong Hard Disks 5 Megabyte \$1359.00 10 Megabyte \$1759.00 15 Megabyte \$2159.00 Maynard Electronics Floppy Controllers w/Parallel \$209.00 Floppy Controllers w/Serial \$239.00	COMPUTER PRODUCTS FOR APPLE MBI: VIP Graphics Card \$109.00 Appletime Clock Card \$ 75.00 Silicon Valley Systems: Final Analysis \$149.00 Word Handler \$115.00 Continental: Home Acct. \$ 49.00 On-Line: Screenwriter II Pro \$139.00 Vislcorp: Visidex \$180.00 Visifiles \$180.00 Visicalc \$180.00 Visitrend/Plot \$225.00 Stoneware: DB Master \$149.00 DB Utility Pak \$ 65.00 T & G Products: Joysticks \$42.00 Select-a-Port \$42.00 Game Paddles \$28.00 Davong Hard Disks 5 Megabytes \$1359.00 10 Megabytes \$1759.00 15 Megabytes \$2159.00 Ram Cards Microsoft 16K \$75.00 Generic 16K \$60.00 Microsoft CP/M Z80 Card \$249.00 80 Column Card: Videx w/software \$269.00

Send orders and inquiries to:

Computer Apparatus™

P.O. Box 32063 • Aurora, Colorado 80012

Telephone Inquiries: (303) 759-9251

Monday thru Friday — 9:00 a.m. to 5:00 p.m. (Mountain Standard Time)

**We built our reputation on low prices
 for the informed computer user.**

DELIVERIES: 2 - 4 weeks average
 PERSONAL CHECKS: Cashier's check and money order will receive shipping preference.
 VISA & MASTERCARD: Add 4% to total
 CATALOG: Send for full pricing details
 Prices subject to change without notice
 SHIPPING: UPS add \$2.00 plus 3% of order total, or we calculate exact freight.

return/linefeed pair when given the newline argument (LF). But then `putc()` behaves improperly when we use it to write a binary file. Aztec C provides two versions of `putc()`; the second version expands newline characters to carriage-return/linefeed pairs, while the first does not. In C/80, a file is opened in either text or binary mode; this determines whether newlines are given special treatment on output.

My own inclination is to avoid all special handling of the newline character: when writing '\n' to a file or device, simply write the lone character as it stands. You can always pass text files through a trivial filter that expands the newlines to carriage-return/linefeed pairs. In the case of certain devices, such as the console, the lack of expansion is a nuisance, and it would seem that you should allow drivers for particular devices to prescribe special treatment of particular characters. This is what Aztec C does for the CP/M devices `con:` and `lst:`. Alas, that interfered with my attempt to perform even low-level I/O to the `lst:` device (an Epson printer) for graphics control.

Actually, I like the idea of having the device drivers rather than the formatting function `printf()` (or worse yet, `write()`) perform the expansion themselves. What is needed to resolve my graphics problem is simply another device name for the printer—one that exercises the same communication ports, but with a binary protocol.

A related problem occurs with detection of the EOF (end of file) condition. Under Unix, a file may contain any integer number of bytes, and it is possible to read a file down to the end using a loop such as:

```
while (read(fd, &c, 1)) {  
    ...  
}
```

Because `read()` returns the number of bytes actually read, a returned value of 0 signifies EOF. Under CP/M, files have physical lengths equal to some integral number of 128-byte sectors. A text file might not end on such a boundary; the CPMEOF (Control-Z) character is used to delimit the end

of the file. In the unlikely event that one were reading a text file a byte at a time using `read()`, it would be necessary to modify the loop shown above:

```
while (read(fd, &c, 1) && c != CPMEOF) {  
    ...  
}
```

Some Actual CP/M C Compilers

There are quite a few C compilers around, three of which I've used to a significant degree: `small-c`, BDS C, and Aztec C. Each is remarkable in its own way. They will serve as illustrations of how C has been implemented for microcomputers.

The small-c code generator produces assembly mnemonics for the 8080 but can be made to produce mnemonics for other processors as well.

small-c: `small-c` is a subset of the C language and was created by Ron Cain, who simply wanted a compiler for his home computer. It is described in his article "A Small C Compiler for the 8080s" (see *Dr. Dobb's Journal*, Number 45). The `small-c` compiler is written in `small-c` and is fully compatible with Unix C. It had to be; the first working version was compiled on a Unix system.

`Small-c` has `char` and `int` data types and pointers to each of these; there are no floats, longs, multiply-dimensioned arrays, or structures. Control statements include `if`, `else`, and `while`; there is no `for`, `do`, or `switch`. Only a subset of the operators is supported, not including `&&`, `||`, or the assignment operators `+=`, `*=`, etc. Nonetheless, the language is clearly useful: it served to write its own compiler.

Although it was not originally intended for CP/M, a CP/M version of `small-c` is available from the Code Works of Santa Barbara, CA. This includes full source code for the compiler, which is in the public domain, and a run-time support library, which is copyrighted. Many extensions of this compiler have appeared, includ-

Here's where to find more printer for less.

DIGITAL ENTRY SYSTEMS
27 Spruce Street
Waltham, Massachusetts 02154
(617) 899-6111

GENERAL MICROCOMPUTER
Georgetown Center
52303 Emmons Road, No. 26
South Bend, Indiana 46637
(219) 277-4972

INTECH GROUP
Royal Commerce Center
2025 Royal Lane
Dallas, Texas 75229
(214) 241-1717

KALTRONICS
702 Landwehr Road
Northbrook, Illinois 60062
(312) 291-1220

MICROAMERICA
21 Putnam Street
Needham, Massachusetts 02194
(617) 449-5807

MICRO DISTRIBUTOR
11794 Parklawn Drive
Rockville, Maryland 20852
(301) 468-6450 or (800) 638-6621

MICROWARE DISTRIBUTORS, INC.
20415 S.W. Blanton Avenue
Aloha, Oregon 97007
(503) 642-7679

MONROE DISTRIBUTING, INC.
2999 Payne Avenue
Cleveland, Ohio 44114
(216) 781-4600

PARAGON SALES
780 Charcot Avenue
San Jose, California 95131
(408) 263-7955

PREMIER SOURCE
18380 Enterprise Lane
Huntington Beach, California 92648
(714) 842-2208

STAR DATA, INC.
3031 E. Indian School Road, Suite 16
Phoenix, Arizona 85016
(602) 955-9233

SYSPRINT, INC.
7777 South Central Expressway
Suite 2A
Richardson, Texas 75080
(214) 669-3666

TRANS ALASKA DATA
SYSTEMS, INC.
200 Center Court
Anchorage, Alaska 99502
(907) 561-1776

TOSHIBA

Toshiba's P1350.

It's the three-in-one printer that gives you so much because it offers so many choices.

Choose rapid-fire letter quality printing at 100 CPS.

Or draft quality printing at speeds up to 192 CPS.

And the P1350 prints graphics, too.

It gives even more.

More pins (24) in the printhead than anyone else for a 180-dot-per-inch density pattern with a single pass.

More choices of pitches and character fonts.

Plus more reliability, more performance, and more paper feed options, including Toshiba's ultra-

dependable automated sheet feeder.

And asks very little.

The suggested list price of Toshiba's spectacular three-in-one P1350 printer is just \$2195, plus options of your choice.

So find out how much you can get for so little. Write Toshiba America, Inc. today.

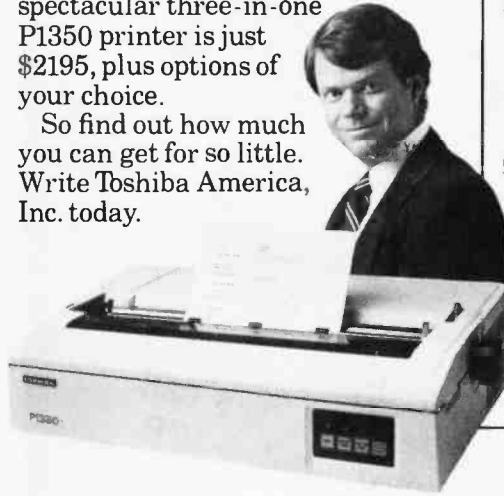

Show me how you give so much for so little.

Please send me more information on Toshiba's P1350 printer.

Mail to: Toshiba America, Inc.
Information Systems Division
2441 Michelle Drive, Tustin, CA 92680
Or call toll-free: 1-800-457-7777

NAME _____

TITLE _____

COMPANY _____

ADDRESS _____

CITY _____

STATE/ZIP _____

PHONE _____

"NO OTHER PRINTER GIVES SO MUCH, YET ASKS SO LITTLE."

TOM WATSON, golf professional

MODEL	TOSHIBA P1350
PRINTING SPEED	100 CPS - Letter Quality 192 CPS - Draft Quality
# OF PRINT HEAD PINS	24
POPULAR FONTS	Prestige Elite, Courier 10, Data Processing
CARRIAGE SIZE	15" - 132 characters at 10 pitch
GRAPHICS	Yes - 180 x 180 dots per. inch
PAPER FEED OPTIONS	Bi-directional Tractor Automatic Sheet Feeder (ultra reliable-sound dampening)
INTERFACES	Centronics (industry standard) RS-232C (industry standard)
COMMAND SET	Qume Sprint 5 compatible
COMPATIBLE WITH	IBM, DEC, Apple, and other microcomputers
PRICE	\$2195

In Touch with Tomorrow
TOSHIBA

For further information, contact: Information Systems Division TOSHIBA AMERICA, INC., 2441 Michelle Drive, Tustin, CA 92680

DIAMOND DELIVERS!

Superwriter \$179
 Wordstar \$259
 Visicalc \$169
 Infostar \$275
 dBase II \$ call
 Supercalc 2 \$179
 dBase II/Quickcode \$589
 Wordstar/Mailmerge/Spellstar/Star Index \$389.

	LIST	OUR PRICE		LIST	OUR PRICE
Micropro*	\$250	\$139	Visicorp*	\$250	\$169
MAILMERGE	\$250	\$145	VISICALC	\$375	\$289
SPELLSTAR	\$645	\$350	VISIWORD	\$300	\$219
WORDSTAR/MAILMERGE	\$250	\$145	VISIFILE	\$300	\$219
SUPERSTORT	\$250	\$219	VISITREND/PLOT	\$300	\$219
REPORTSTAR	\$350	\$ 89	DESKTOP PLAN	\$345	\$249
CALCSTAR	\$145	\$ 89	VISISCHEDULE	\$275	\$195
Sorcim*	\$195	\$129	Microsoft*	\$695	\$479
SUPERCALC	\$295	\$179	SOFTCARD	\$195	\$149
SUPERCALC 2	\$295	\$179	MULTIPLAN		
SUPERWRITER	\$195	\$129	PREMIUM SYSTEM		
SUPERSPELLGUARD			MOUSE	\$650	\$429
Ashton-Tate*	\$700	scall	Condor*	\$295	\$215
dBASE-II	\$400	\$309	CONDOR 20-3	\$ 99	\$ 65
THE STRATEGIST	\$295	\$209	Fox & Geller*	\$295	\$215
FRIDAY			QUICKCODE		
Supersoft*	\$425	\$329	dUTL	\$150	\$ 99
FORTRAN	\$500	\$359	dGRAPH	\$125	\$ 89
C COMPIER	\$125	\$ 99	Continental*		
PERSONAL DATA BASE	\$295	\$ 99	HOME ACCOUNTANT PLUS	\$350	\$259
SCRATCHPAD			FIRST CLASS MAIL	\$400	\$295
Lexisoft*	\$495	\$255	Digital Research*	\$200	\$145
SPELLBINDER			CONCURRENT CP/M 86		
Lifetree*	\$195	\$129	PASCAL MT+ 86		
VOLKSWRITER	\$225	\$145	C BASIC 86	\$195	\$129
VOLKSWRITER INTL.			Alpha Software*	\$145	\$109
Microstuf*	\$195	\$135	APPLE-IBM CONNECTION	\$295	\$199
CROSSTALK	\$500	\$365	THE EXECUTIVE PACKAGE		
Metasoft*			DATA BASE MANAGER II	\$680	\$499
BENCHMARK	\$350	\$199	Quadram*	\$295	\$229
Information Unlimited*	\$225	\$129	QUADLINK		
EASYWRITER II	\$400	\$265	QUADCOLOR	\$395	\$289
EASYSPILER			RAM EXPANSION BOARDS	\$595	\$425
			64K EXPANDABLE		
			256K		

At Diamond Software we offer the best selling business application software for your IBM PC, CP/M or Apple Computer at the lowest possible prices. And we maintain a complete technical department to assist you before, during and after your system purchase. Not only that, we offer same day shipment on most items and we accept Visa, Mastercard and also American Express. We'll even pay the shipping charges if you send us a money order, cashiers, company or personal check. Purchase orders are gladly accepted from qualified organizations and we welcome dealer inquiries. Call Diamond today, you'll be glad you did.

TO ORDER CALL TOLL-FREE 1-800-227-0545

Diamond Software Supply 484 Lake Park Ave., Suite 123 • Oakland, CA 94610
 For price quotes, information, or in California call 1-415-893-7676. We credit your order for the call. Technical Department (415) 893-7678. International Telex 338139 (attn. 149)

Support, Service and Price.

Shipping/Handling UPS surface \$3.00 plus an additional \$3.00 per item for UPS Blue. C.O.D. orders add \$4.00. For personal check allow 2 weeks for delivery. All items subject to availability, prices subject to change without notice. Calif. residents please add 6 1/2% sales tax. *IBM is a registered trademark of International Business Machines. CP/M is a registered trademark of Digital Research.

ing C/80 by the Software Toolworks of Sherman Oaks, CA, which implements a more complete subset and produces more efficient code.

Besides providing the student an extraordinary opportunity to probe compiler internals, small-c has the advantage of being easily transported to other machines. The code generator, as written, produces assembly mnemonics for the 8080; it is a simple matter to arrange for it to produce mnemonics for other processors as well. This has been done a number of times; I did it for Texas Instruments' 9900, and my article "Small-C for the 9900" (see *Dr. Dobbs' Journal*, Number 69) gives some pointers on what's involved.

BD Software C: BDS C was one of the early entries in the CP/M world and was the first (so far as I know) to adopt K&R as its guiding document. Despite this, it is not entirely compatible with either the language definition of Appendix A or the conventions of the standard I/O library. For example, BDS C assigns the operators && and || equal precedence, whereas the much-photocopied page 49 of K&R shows higher precedence for &&; thus, an expression such as

`a < b || c == 0 && d > 2`

will be evaluated differently by BDS C and regulation C. A declaration of the form

`char (*bitmap)[ROWSIZ];`

is useful for preparing bitmap to behave like a two-dimensional array without reserving storage space in advance; but according to the manual, BDS C will treat the declaration as equivalent to

`char *bitmap[ROWSIZ];`

which is totally different. There is also the business of standard library functions like `fopen()` and `read()` behaving differently than their identically named K&R counterparts.

These incompatibilities, while unfortunate, are not severe; with modest effort, a BDS C program can be converted to run under Unix.

LET THE "ANGEL"™ DO THE WAITING

Two RS-232C Connectors for serial input and output

6 Leds to indicate power, transmission and reception status, buffer activities, page number, etc.

SKIP and REPRINT provide independent page controls to reprint portions of documentation.

40 Pin Expansion Bus available for future expansion

COPY provides convenient one key operation for single copy or multi-copy of text

3 externally accessible Dip Switches for baudrate, device type, and parallel and serial selections. Selections can be made without losing buffer

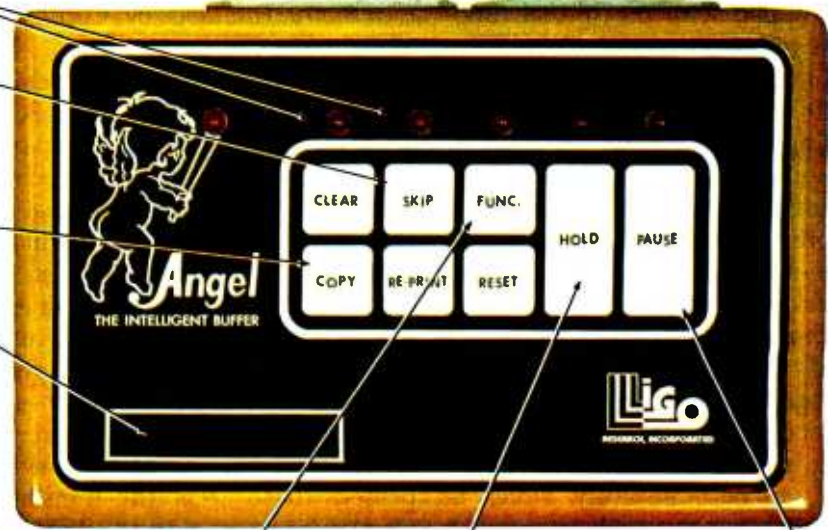

Function keys expand the useful commands to more than 10, including: hex dump, memory test, remote loading, etc.

8 easy-to-operate membrane key switches.

Independent PAUSE and HOLD controls to suspend transmission and reception.

Two 20 Pin Edge Connectors for parallel input and output

Connect an "ANGEL" between your computer and your printer, and let the "ANGEL" do the waiting

Your valuable computer spends 95% of its time waiting for the printer to catch up...and while the computer waits, the payroll continues.

The computer sends data to the "ANGEL" at speeds up to 19.2K baud. The "ANGEL" stores data and sends it to the printer at a speed the printer can handle, and your computer is free to continue working without interruption.

A USER WRITES:

"I tried the "ANGEL" with my Altos system connected to an Epson MX-100, both set at 9600 baud. Without the "ANGEL" it takes 30 minutes to print 210 doctors' requisition forms. With the "ANGEL" installed, my computer is free after 90 seconds."

With "ANGEL'S" self diagnostics and memory test, the entire system thoroughly checks itself every time you power up.

PAGE REPRINT is another unique feature. EXAMPLE: You are printing a 32 page report, and the paper jams at page 11. Reset the printer to the top of the form, press PAGE REPRINT, and resume printing at the top of page 11. Want to restart two pages back? Press PAGE REPRINT twice, and you resume at page 10.

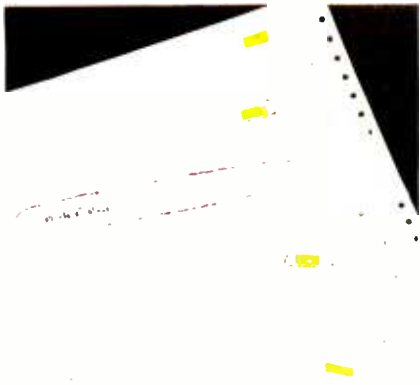

PAGE REPRINT

...And think of these other possibilities: HEX DUMP. Display or printout every bit of data your computer sends out to the printer in an easy-to-read Hexidecimal and ASCII format. A must for your programmer. Pause and Hold for real time programs. Page skip for selective printing. What a waste to print the entire documentation if you only need part of it.

Simple external switch settings, let the "ANGEL" accept either RS-232 serial or Centronics parallel data and can output either/or in any combination, (S,S,S,P,P,S,P-P). The "ANGEL" is compatible with almost all Micro-Computers, and can be installed by anyone in minutes. Switches are clearly marked for ease of operation, and a concise, USER FRIENDLY operator reference card is included with each unit. The "ANGEL" has a full one year limited warranty.

THE "ANGEL" WILL NEVER KEEP YOU WAITING



HEX DUMP

"ANGEL" is compatible with almost all Micro-Computers, including IBM, Apple, TRS-80, Vector Graphic, NorthStar, Altos, Xerox, Heath, Zenith, NEC, DEC, etc., with RS-232 serial, Hardware Handshaking, or Centronics compatible parallel interface. The manufacturer reserves the right to change the product specification.

ANGEL, The Intelligent Buffer, features:

- 64K Byte Memory Size
- Four Interface Modes in one unit:
 - Serial to Serial
 - Parallel to Parallel
 - Serial to Parallel
 - Parallel to Serial
- Serial Baudrate from 110 to 19.2K Baud
- Single, Multiple and Continuous Copy
- Clear/Reset
- Pause/Hold
- Page Skip
- Page Re-print
- Page-Pause
- Hex-Dump
- Self-Diagnostics
- Space Compression to extend the effective buffer size to more than 128K
- Price - \$295.00

TO ORDER:
CALL TOLL FREE 1-800-323-3304
OR SEND CHECK OR MONEY
ORDER TO LIGO RESEARCH

Please rush me () "ANGEL(S)" @ \$295.00 each

Sub total _____
ILLINOIS ONLY Add 6% U.S. sales tax _____
Delivery charge \$4.00 _____
TOTAL _____

Charge my () VISA () MASTERCARD
MY ACCT. # IS _____
EXPIRATION DATE _____

Conversion in the opposite direction will, in general, be far more difficult, owing to BDS's lack of long ints, doubles, floats, static variables, and initializers.

On the positive side, the BDS C compiler is exceptionally well suited to the CP/M environment. Its library is equipped with the special functions you really need to use the machine: `inp()` and `outp()` for doing port I/O, `bdos()` and `bios()` for communicating with the operating system, and convenience functions like `kbhit()` for testing console status.

More important, the compiler is written in assembly language and optimized to give acceptable performance even on a relatively slow 8080-based microcomputer. (I've never seen another compiler under CP/M-80 that could match its speed of compiling and linking; debugging sessions can be quite lively, which is normally only true with interpreted languages).

Aztec C: There are two compilers I use nearly every day: one runs under Unix version 7 on my company's own 68000-based microcomputer, and the other is the Aztec C compiler that runs on my home Z80 system under CP/M. I routinely move code between the two machines and find that, except for allowable array sizes and execution speed, the behavior in each environment is the same. We have more than upward compatibility here: in the domain of applications programs, we are close to functional equivalence.

Aztec C supports all language features defined in K&R Appendix A except bit fields. A healthy subset of the standard library is supplied, along with source code. Even the mathematical function library, except for the Bessel functions, is provided. That works out well for me, because many of the applications programs I write involve FORTRAN-style number crunching.

Actually, the treatment of the scientific-function library has been done especially well and deserves elaboration. You might suppose that writing routines for sine and cosine is not such a difficult task, but there are many pitfalls for the unwary. The

Unix C implementers took this problem seriously and based their code upon the mathematical treatise "Computer Approximations" by Hart et al. The implementers of Aztec C likewise turned to expert authority for guidance, employing the more recent work *Software Manual for the Elementary Functions* by Cody and Waite.

This book contains a series of recipes for writing the standard FORTRAN scientific functions. It also provides a testing program for each of the functions, whereby the final accuracy may be assessed. Out of curiosity, I applied these tests to Microsoft FORTRAN and obtained a surprising result: nearly every function, in both single and double precision forms, shows excessive loss of accuracy over at least some interval of its domain. Aztec C, having passed these tests (in translated form), may be considered reliable for accurate scientific computation.

Aztec C is somewhat weaker than BDS C in its CP/M interface. The function `getchar()`, for example, buffers input until a carriage return is detected; it would be more convenient, as in BDS C, to have `getchar()` return its value upon receipt of a single character. The buffering action is also performed under Unix, by the way; there, you get around it by turning on a flag called `CBREAK` that forces keystroke response. It can be circumvented in Aztec C as well, by redefining `getchar()` or creating a new function, such as

```
#define getkey() bdos(1)
```

or else

```
#define getkey() bdos(6,0xff)
```

depending on the effect you desire.

Further C Compilers: Guidelines for Implementors

Several new C compilers have recently appeared, and more may be expected to follow. In what ways could these improve on what has already been achieved? Of course they must be complete implementations; if Aztec C can do this, what ex-

cuse is there for providing any less?

Portability has to be a main consideration, especially given the emergence of progressively more powerful microprocessors. A formal standard is clearly needed; until it arrives, common sense suggests to me the following simple rule: do not redefine any of the functions appearing in sections 2 and 3 of *The Unix Programmer's Manual*, Volume 1.

The temptation to alter a function definition must occasionally be very great, as in the case of omitting `arg0` from `exec()` or making the `n` in `read(fd, buf, n)` stand for a number of sectors rather than bytes (both offenses are seen in BDS C). In the latter case, an alternative would be to coin a different name—say, `secd()` instead of `read()`—or, following the example of Walt Bilofsky, the implementer of C/80, retain the meaning of `read(fd, buf, n)` but restrict `n` to be a multiple of the sector size. A little discipline is all that's required.

The discussion of the preceding sections reveals the Unix standard library as a rich source of ideas for attractive features. Can `system()` be done in a tasteful way? Can anything useful be done with interrupts (`SIGNAL(2)`) or communications (`PKON(2)`, `PKOPEN(3)`)?

Bear in mind the role of C as a "high-level assembler." It is intended to allow efficient access to the features of the underlying machine, to provide the capabilities of an assembler with the advantages of an expressive syntax. BDS C has set a fine example with rapid compilation, modest object-code size, and appropriate library enhancements such as `inp()` and `outp()`, `bios()` and `bdos()`. More can be done.

The ability to open devices as files has already been discussed. This provides a uniform interface to the device, which can be used freely in C programs. The drivers are easier to write and maintain in C than they would be in assembly language. Another area that suggests itself is support for ROM-based applications. Many compilers allow specification of addresses for code and data areas, but that is only part of what's required. There should be convenient

HICKORY HILL COMPANY
 BAL. DATE: 12 31 1979
 STATEMENT OF EXP. FOR YEAR 1979

CATEGORY	PL.	ACTUAL
SALES	48,000	51,000
COST OF GOODS	25,000	25,000
NET SALES	23,000	26,000
ADMINISTRATION	10,000	6,000
ADVERTISING	4,000	4,000
RESEARCH	3,000	3,000
TOTAL COSTS	17,000	13,000

HIGH TECHNOLOGY REQUIRES HIGH PERFORMANCE ACCESSORIES

In the fast moving, high technology world of microcomputers, the need for high performance accessories often gets overlooked.

Discwasher, recognized as a world leader in audio/video care accessories, understands this need and has developed a line of computer accessories to allow users to get the most from their computer hardware.

The easy-to-use *Discwasher*[®] *Disk Drive Cleaner* is both a problem preventer and problem solver. Its dry format safely cleans single or double-sided drives without altering the delicate head alignment or doing possible damage to rubber drive parts with solvents.

The *Discwasher*[®] *Computer Cassette Drive CareSet*[™] is a total maintenance package for your cassette drive system. It includes both the *Discwasher*[®] *Computer Cassette Drive Head Cleaner* and the *Computer Cassette Drive Mechanism Cleaner*. Together, these two maintenance units can keep the high resolution heads and the critical drive system of your cassette drive system in optimum performance.

The *Discwasher*[®] *DiscKeeper*[™] is a magnetically shielded storage system for floppy disks that takes up no more space than conventional folder packs. *DiscKeeper* protects against stray magnetic fields which can destroy valuable software. Three *DiscKeeper* sizes provide loss-free storage and protection for transporting any size disk format.



discwasher

1407 NORTH PROVIDENCE ROAD, P.O. BOX 6021, DEPT. BY, COLUMBIA, MO 65205 USA

A DIVISION OF JENSEN an ESMARK Company

APPLES ABLE TO DRAW- WHAT NEXT FOR BOY WONDER?

\$795. Personal Plotter Produces Apple Art.

The new Sweet-P™ Personal Plotter™, invented by Whiz Kid Richard Murray will have your Apple® drawing every graphic you will ever need.

Tasty Sweet-P Graphics-to-Go.

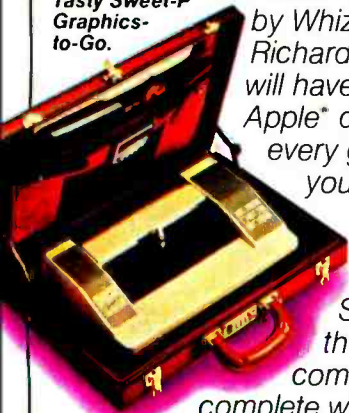

In addition, Sweet-P thoughtfully

comes complete with Sweet-Plot I Software and interface hardware, all for an amazing \$795. And, because Sweet-P fits neatly into a slimline briefcase, you can even see the fruits of your labor while on the road.

\$795
SOFTWARE INCLUDED

With Sweet-P next to your Apple, you quickly create, store, edit and draw high resolution, hard copy graphics that add color and clarity to any business, engineering or scientific presentation.

Sweet-P polishes Apple's performance.

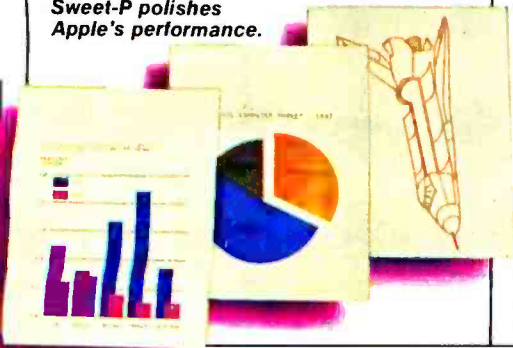

Sweet-P not only draws colorful pie charts, bar graphs, line graphs and alphanumeric lettering, but illustrations as well. On any type of



Sweet-P Software Offers More Apple Applications.

Sweet-Plot™ I Software will have you drawing standard graph formats within minutes—even if you're not familiar with how a plotter works. And, for drawing

Artistic Apples foreseen by Richard Murray, Enter Computer's Whiz Kid Chairman.

paper or transparency material. At an incredible speed of 6 inches per second. And, once stored in memory, information can be drawn in any scale desired—even on paper up to 10 feet long.

With Sweet-P you're not only able to draw your own conclusions, but communicate them more effectively as well.

complex business graphics, there's Sweet-Plot™ II Software by BPS™ limited only by your imagination.

So, when you want to see Apple Art at work, just ask your local computer store to show you the very tasty Sweet-P Personal Plotter.

Sweet-P™

Enter Computer, Inc.
6867 Nancy Ridge Drive
San Diego, CA 92121
Tel: 619-450-0601

mechanisms for excluding unneeded parts of the run-time environment, in order to minimize the size of the compiled object.

I/O redirection is obviously worthwhile, but it imposes a definite overhead, and there should be a means of disabling it when it cannot be used. This is always the case for users who run under a CP/M front end like Microshell, which handles the re-direction at a higher level.

The need for judgment to discern features from bugs is illustrated by the recent tendency to have the C compiler produce assembler output targeted for Microsoft's M80 assembler, despite the fact that L80 is not a suitable linker for a language allowing identifiers with 8 significant characters of mixed case (with the M80/L80 pair, you are limited to 6 characters, and the case distinction is lost). Aztec C supports M80-compatible output but also provides its own assembler and linker that do the right thing, and this is what I use even though the assembler lacks the macro capability of M80. After all, with C, one doesn't make heavy use of assembly-language routines; when, on occasion, they are required, any working assembler will do. ■

Matthew Halfant is a mathematician who, as senior scientist at Bedford Computer Corp. (Tirrell Hill Rd., Bedford, NH 03102), is currently involved with the analytic representation of typographic fonts. He has taught numerous courses in subjects ranging from programming languages to microprocessor-based instrument design.

References

1. Kernighan, Brian W. and Dennis M. Ritchie. *The C Programming Language*. Prentice-Hall, 1978.
2. *Unix Programmer's Manual, Volume 1*, Revised and Expanded Version. Holt, Rinehart and Winston, 1983.
3. *Unix Programmer's Manual, Volume 2*. Seventh Edition, Holt, Rinehart and Winston, 1983.
4. Cain, Ron. "A Small C Compiler for the 8080s," *Dr. Dobbs Journal*, Number 45.
5. Halfant, Matthew. "Small-C for the 9900," *Dr. Dobbs Journal*, Number 69.
6. Hart et al. *Computer Approximations*. Robert E. Krieger Publishing Company Inc., 1978.
7. Cody, William J. and William Waite. *Software Manual for the Elementary Functions*. Prentice-Hall, 1980.

Inventory Control

- provides ON LINE information to all other modules.
- purchase orders with review or automatic ordering mode.
- back ordering system included.
- 25 items per bill-of-material.
- 1500 stock items per diskette with automatic advancement!
- sales analysis, stock labels + more.

PHONE
OR
WRITE
For A
Brochure

Demo \$59

Complete
System
\$595

Accounts Receivable

- sales orders with packing slips.
- invoices from sales orders support back ordering system.
- invoices for point-of-sale.
- multiple discounts and tax rates.
- alphabetical sorting of customers.
- supports partial payments, finance charges, aged balances, statements.
- 500 customers and 3000 transactions per diskette.

PEP BUSINESS SYSTEM

3970 SYME DR., CARLSBAD, CA. 92008
(619) 434-6023

Accounts Payable

- check writing with automatic posting to vendors and bank accounts.
- enter A/P invoices with automatic posting to inventory and purchase orders.
- supports partial payments, aged A/P balances and earned discounts.
- monthly check, deposit & petty cash register.
- Uses NEBS 9024 carbonless checks.

COLUMBIA
•
COMPAQ
•
HYPERION
•
CORONA
•
EAGLE PC
•
RAINBOW
100

Payroll (optional-\$200⁰⁰)

- only requires input of hours worked.
- automatic calculations of pay and deductions.
- week, bi-wk., bi-mo. or mo. periods.
- keeps complete QTR and YTD pay journal records and prints YTD info on check stubs and all reports.
- hourly, salaried and commission employees.
- uses SAME NEBS 9024 checks.

Interactive General Ledger

- automatic posting, complete audit trail.
- asset depreciation, complete G/L reports: daily journal, trial balance, operating and balance sheet.

You don't have to be an accountant to use it!

Integrated software for MS-DOS Systems:
IBM-PC & XT • ZENITH Z-100
VICTOR-9000 • TEXAS INSTRUMENTS PC

Real-Time C

for 8080, Z80

A Run-Time Library for Whitesmiths' C 2.1

- Fast execution
- ROMable
- No royalties
- Fully reentrant machine support
- CP/M file support
- Error checking
- Usable with our AMX Multitasking Executive

Benchmarks

1. Int to ASCII conv.
2. Long to ASCII conv.
3. Long random number generator
4. Double 20 x 20 matrix multiply
5. File copy (16kb)

4 Mhz Z80. 8" SD diskette. Times may vary with processor, disks, etc.

AMX and Real-Time C are trademarks of KADAK Products Ltd.
A-Natural is TM of Whitesmiths Ltd. CP/M is TM of Digital Research Corp.
Z80 is TM of Zilog Corp.

Real-Time C \$ 95

manual only \$ 25

source code \$950

Intel mnemonic \$ 50

to A-Natural converter

KADAK Products Ltd.

206-1847 W. Broadway Avenue
Vancouver, B.C., Canada V6J 1Y5
Telephone: (604) 734-2796
Telex: 04-55670

Circle 227 on inquiry card.

August 1983 © BYTE Publications Inc 267

www.americanradiohistory.com

Annotated C

A Bibliography of the C Language

by Terry A. Ward

You have probably read a great deal about the C language, but just where can you find the books, articles, and reviews that will make this less-than-well-known language part of your repertoire?

While struggling to find reviews of a C compiler that I was interested in purchasing, I thought that other microcomputer users might be having the same problem locating information. This bibliography of 100 items is my attempt to provide some guidance to the literature pertaining to the C programming language.

The material is listed alphabetically by author in both book and periodical sections, and I have also provided an index to the bibliography by subject matter and type of C used (where applicable).

Finally, these are my own opinions and do not reflect the views of BYTE. For me, C is *the* language for micros. To paraphrase a popular book, "Real microcomputers don't use BASIC!"

Books

01 Bell Telephone Laboratories Inc. *Unix Programmer's Manual: Volume 1 and Volume 2* (New York: Holt, Rinehart and Winston, 1983).

These two volumes contain a wealth

of information on C and particularly its use with Unix. Volume 1 contains the system calls and subroutines in the standard C libraries and their calling sequence. Volume 2 has a reprint of the C programming language reference manual, an article on lint (the C program checker), and technical tours through the Unix C compiler and the portable C compiler by their respective authors.

02 Feuer, Alan F. *The C Puzzle Book: Puzzles for the C Programming Language* (Englewood Cliffs, NJ: Prentice-Hall, 1982).

In this unique book, Feuer presents fragments and sections of C code and asks, "What does this code do?" Used in conjunction with a working C compiler and Kernighan and Ritchie's book, it provides an excellent way to tackle the nitty-gritty of the language in an enjoyable fashion. Caution: as the author states, "Some of the code is *atrocious*." Style should be learned from Kernighan and Ritchie. Feuer provides interesting puzzles to help learn the language. Heartily recommended.

03 Hancock, Les and Morris Krieger. *The C Primer* (New York: McGraw-Hill, 1982).

This introductory book is paced slowly for beginners, with numerous

short examples that depict isolated features of the language. There are more illustrations in this tutorial than in any other C book to help clarify some of C's unusual points.

04 Kernighan, Brian W. and Dennis M. Ritchie. *The C Programming Language* (Englewood Cliffs, NJ: Prentice-Hall, 1978).

This is the definitive work on the C language. Don't read any further until you have this book! Topics such as pointers are obscure, but the book as a whole is excellent.

05 Plum, Thomas. *Learning to Program in C*. (Cardiff, NJ: Plum Hall, 1983).

The newest addition to the all too meager C book literature. Designed to teach programming in C, with emphasis placed upon the programming of portable C applications.

06 Purdum, Jack. *C Programming Guide* (Indianapolis, IN: Que Corporation, 1983).

This is another introductory book on C, oriented toward using C on microcomputers. Most of the programs in the first half of the book will work with inexpensive subsets of the C language, and often the equivalent program in BASIC is shown.

07 Zahn, C. T. *C Notes: A Guide to the C Programming Language*

Since 1978

- REPUTATION BACKED BY YEARS OF EXPERIENCE.
- PIONEER IN DIRECT TO CONSUMER SALES OF MICRO COMPUTERS AND ELECTRONICS
- MILLIONS OF DOLLARS IN SALES OVER THE YEARS
- TENS OF THOUSANDS OF CUSTOMERS
- HONEST
- RELIABLE
- LARGE INVENTORY
- NAME BRAND PRODUCTS



Micro Management Systems, Inc.

2803 Thomasville Road East
Cairo, Georgia 31728
(912) 377-7120

**DISCOUNT
PRICES**



**BUY
DIRECT**

**It's simple. . . .
CALL & SAVE MONEY**

"TELEMARKETING WORKS"

**1-800-841-0860
CONVENIENT ORDER ENTRY**

Ga & Info 912-377-7120

COMPUTERS & EQUIPMENT



FROM

\$898

ACE 1000

ACE 1200

TRS-80 COMPUTERS



**PURE
RADIO SHACK
EQUIPMENT**

	DISCOUNT PRICED FROM
MODEL 4 TRS-80.....	'828
MODEL 12 TRS-80.....	'2639
MODEL 16 TRS-80.....	'4012
MODEL 100 TRS-80.....	'677
MC-10 TRS-80.....	'99
COLOR COMPUTER.....	'CALL

WE SELL THE COMPLETE LINE
OF TRS-80 COMPUTERS
AND ACCESSORIES

Commodore COMPUTERS

FROM **\$CALL**
VIC 20 COMPUTER
COMMODORE 64
VIC 1541 DISK DRIVE
VIC 1525 PRINTER
VIC 1701 MONITOR
CALL & SAVE

DATA FLEX
APPLICATIONS
DATA BASE
BY DATA ACCESS
'CALL

ATARI
1200 XL
COMPUTER
'CALL

**EPSON
PRINTERS**
FROM **\$CALL**

FX-80.....	SAVE
RX-80.....	SAVE
MX-80.....	SAVE
FX-100.....	SAVE

**SMITH
CORONA**
TP-1 DAISY
WHEEL PRINTER
FROM **\$489**

**Star
PRINTERS**
FROM **\$309**
GEMINI 10 & 15

**OKIDATA
PRINTERS**

FROM **\$339**
MICROLINE SERIES
•80 •82A •83A
•84P •92P •93P
PACE MARK 2350P

**NEW
PRODUCTS**
'CALL

brother
DAISY WHEEL
PRINTERS
'CALL

Dynax
DX-15
DAISY WHEEL
'CALL

Hayes®
MODEMS
FROM **\$239**

MICRO MODEM I
SMART MODEM 300
SMART MODEM 1200

**C. Itoh
PRINTERS**
PROWRITER
8510.....'397
NEW! 8600.....'CALL

**QUADRAM
CORPORATION**
•APPLE BOARDS
•IBM BOARDS
•MICROFAZERS
'CALL

Novation
MODEMS

FROM **\$119**
•J-CAT •D-CAT
•CAT •AUTO CAT
•SMART CAT •APPLE CAT

SILVER-REED
DAISY WHEEL
PRINTERS
'CALL

NEC
3550 SPINWRITER
\$1987

Panasonic
•PRINTERS
•MONITORS
'CALL

NOTICE

ALL PRODUCTS WE SELL ARE BRAND NEW AND COVERED BY THE MANUFACTURER'S SPECIFIC WARRANTIES. COPIES AVAILABLE UPON REQUEST. WE DO NOT SELL ANY USED, RECONDITIONED, FOREIGN OR INFERIOR MODIFIED EQUIPMENT. PRICES AND PRODUCTS SUBJECT TO CHANGE WITHOUT NOTICE.

**TRS-80
PRINTERS**
COMPLETE LINE
FROM **\$199**

PRINTER CARDS & CABLES
•MICROTEK DUMPLING GX
•GRAPPLER PLUS
•APPLE •IBM
•OSBORNE •ATARI
•TRS-80 •MORE

FREE
UPON REQUEST
•DISCOUNT PRICE LIST
& INFORMATION KIT
WRITE TO:
MICRO MANAGEMENT SYSTEMS
TELEMARKET DEPT. #1
2803 THOMASVILLE RD. EAST
CAIRO, GEORGIA 31728

Verbatim
DATALIFE
DISKETTES
\$CALL

WE SELL IBM P.C.
COMPATIBLES. CALL
FOR YOUR CHOICE.

AMDEK
MONITORS
FROM **\$178**

(New York: Yourdon Press, 1979).

A reference manual and tutorial for C focusing primarily on the portable features of the language. All major topics are covered and the book is an excellent supplement to Kernighan and Ritchie (see above). Each chapter concludes with a concise syntactic summary chart. Recommended for any C library.

Periodicals

08 Anderson, Bruce. "Type Syntax in the Language 'C': An Object Lesson in Syntactic Innovation," *ACM SIGPLAN Notices* 15(3): 21-27 (March 1980).

A technical and critical look at C directed especially at the "infelicities" of the typing of variables in C. Anderson considers the syntax of C to be messy and irregular.

09 Anonymous. "Bell Labs' 32-Bit C/UNIX Micro," *Pipes and Filters* 1(1): 4 (June 1981).

A brief report on Bell Labs' MAC-32 microprocessor chip. The chip itself is optimized for data manipulation using C.

10 Anonymous. "BDS C Compiler Version 1.45," *Lifelines* 2(9): 39-41 (February 1982).

A notification and evaluation of a new version of BDS C compiler.

11 Anonymous. "The C Programming Language," *Mini-Micro Software* 6 : n.p. (1981).

A description and brief history of the C language, including a review of Kernighan and Ritchie's book.

12 Ashcraft, Steven E. "Ultra Low Level Programming Using a High Level Language," in *Microcomputer Research & Applications: Proceedings of the First Conference of the HP/1000 International Users Group*, Helen K. Brown, ed.; pp. 168-184 (Elmsford, NY: Pergamon, 1981).

This paper describes the use of C in the implementation of a driver for use with terminal type devices on a Hewlett-Packard HP1000 minicomputer. Includes a discussion of the advantages and disadvantages of systems programming in a higher-level

language. The C code for the driver is also shown.

13 Bailes, P. A. C. "A Coroutine Package for C," *Australian Computer Science Communications* 1(4): 306-309 (December 1979).

Description of a coroutine package for C. An interesting example of the extensibility of C.

14 Barach, David R. and David H. Taenzer. "A Technique for Finding Storage Allocation Errors in C-Language Programs," *ACM SIGPLAN Notices* 17(5): 16-23 (May 1982).

Technical description of a tool for the diagnosis of allocation errors in C programs. Consists of a traced replacement for the standard memory allocator, plus a program to analyze traces. This technique is said to make large programs more robust.

15 Barach, David R. and David H. Taenzer. "A Technique for Finding Storage Allocation Errors in C-Language Programs," *ACM SIGPLAN Notices* 17(7): 32-38 (July 1982).

Same article as Barach and Taenzer (May 1982).

16 Birman, H. K., L. N. Rolnitzky, and J. R. Biggee. "A Shape Oriented System for Holter ECG Analysis," in *Computers in Cardiology*, 1978.

Use of C in an application where assembly language would be used traditionally for speed considerations—medical signal processing.

17 Bolton, Bill. "Some Useful C Time Functions," *Dr. Dobb's Journal* 6(8): 16-21 (August 1981).

Nine time and date functions and a demonstration program for an S-100 hardware clock board are presented.

18 Brooker, R. A. "A 'Database' Subsystem for BCPL," *Computer Journal* 25(4): 448-464.

Describes how one would organize a database structure in a language such as BCPL. Contains a useful discussion of structural considerations. The author notes that these ideas should be transferable into a C environment.

19 Burkowski, F. J., W. F. Mackey, and M. H. Hamza. "Micro-C: A Universal High Level Language for Microcomputers," in

Proceedings of the IEEE International Symposium on Mini and Micro Computers (Canada/USA), 1977/1978.

A description of a subset of C for small-computer use.

20 Cain, Ron. "A Small-C Compiler for the 8080's," *Dr. Dobb's Journal* #45: 5-46 (May 1980).

This is the original source for the small-c compiler. Complete source code is included. The language is often used by software experimenters with this as the basis for modification. Small-c does not support floating-point, structures or unions, or multiple-dimension arrays.

21 Cain, Ron. "Runtime Library for the Small-C Compiler," *Dr. Dobb's Journal* #48: 4-15 (September 1980).

Source code and description of the runtime library for the small-c compiler (see Cain, May 1980). The library consists of arithmetic, logical routines as well as the I/O functions for small-c.

22 Christensen, Ward. "Full Screen Program Editors for CP/M-80: Ed Ream's Editor in C," *Lifelines* 3(5): 43-45 (October 1982).

A review of Ed Ream's public-domain editor. A unique feature of the editor is the inclusion of source code (allowing modification and customization by the user). Versions are available from the C Users Group or from Ed Ream. Available in both BDS C and small-c versions.

23 Christensen, Ward. "Full Screen Program Editors: MINCE," *Lifelines* 2(11): 7-11 (April 1982).

A review of the MINCE editor (from Mark of the Unicorn). MINCE is written in BDS C and includes notes for customization. MINCE features excellent documentation, multiple edit capability, split-screen editing, and other EMACS-type features.

24 Christensen, Ward. "MINCE Revisited," *Lifelines* 3(5): 45 (October 1982).

Update of earlier review of MINCE (see Christensen, April 1982). Highlights MINCE's capability for split-screen multiple-file-editing capability.

25 Christensen, Ward. "The

SOFTech MICROSYSTEMS



The Universal Operating System.* Finally, all the tools for your trade.

The UCSD p-System* is the first truly universal operating system ever developed. Its capabilities allow you to develop integrated, high quality applications faster and more efficiently with virtually no limit on size. And whether it's an IBM PC or Displaywriter, an Apple, a DEC, an HP, an Osborne, a Philips, a Sage, a Tandy, or a TI, the p-System is portable across virtually any popular micro made anywhere today. Which means you can develop your program, on any micro-computer, then compile to object code, and it's totally transportable.

All the tools you'll need.

The p-System lets you write your programs using any combination of UCSD Pascal,* FORTRAN-77 and BASIC. Each language operating effectively with the others. So you can take advantage of the best features of each—in a single program.

And you also get a completely integrated set of software development tools that work together to make your job even simpler. Including a screen editor,

macro assemblers, a debugger and a print spooler. There are also portable graphics utilities and native code generation—where and when you need it. And the p-System provides for dynamic memory management, as well as automatic linking, multi-tasking, and more.

Truly universal, truly efficient.

When we set out to develop the p-System, we wanted it to be truly universal, truly portable, truly efficient. And we weren't going to be satisfied with anything less. We didn't think you would be, either.

So now you can get all the tools you'll need to develop applications faster. Less expensively. More dependably. For a much larger market.

All at the same time.

All on one micro.

Finally, once is enough.

Finally, Once is Enough.

For product information or information on how to get a copy of the p-System Application Catalog, call or write to us at SofTech Microsystems.

SofTech Microsystems · 16885 West Bernardo Drive · San Diego, Calif. 92127 · (619) 451-1230

*Universal Operating System is a trademark of SofTech Microsystems Inc. UCSD p-System and UCSD Pascal are trademarks of the Regents of the University of California

Make your 212A modem

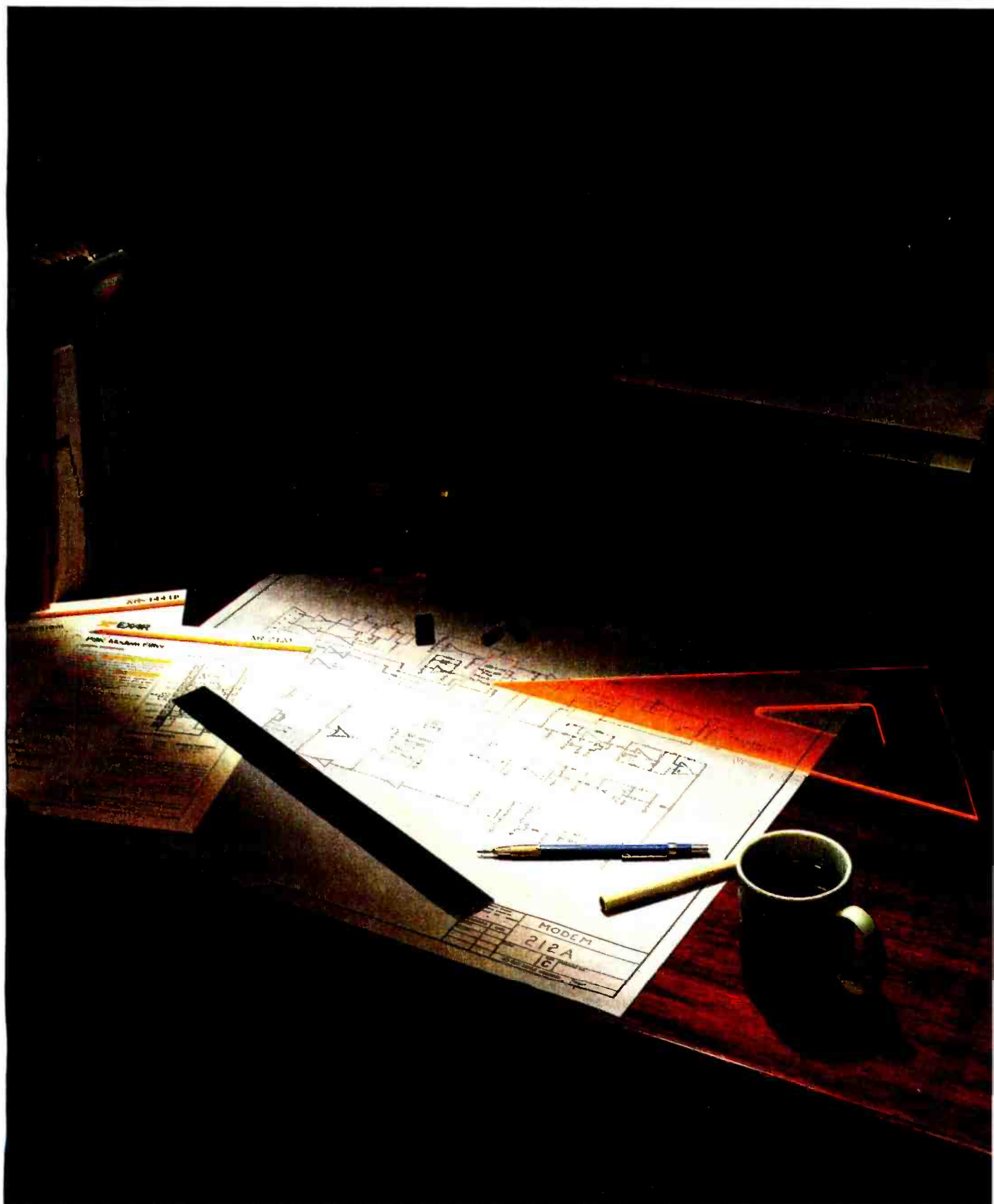

for half the cost.

Your Design Problems are Over

Now available to you are the LSI circuits and software know-how needed for your own design and implementation of an operational Bell 212A compatible modem – all from one experienced source, Exar.

Exar Delivers the Solution

First, you get high technology, quality IC's that form the heart of a 212A modem. The XR2123 CMOS Modular/Demodulator provides the 1200 BPS PSK function, the XR14412 modem system performs the 300 BPS FSK modulation/demodulation function required for 212A compatibility and the XR2120 switched capacitor filter, also CMOS technology provides the 1200 and 300 BPS filtering requirements for the modem.

But, Exar does not stop there. In order to implement these devices into a compatible Bell 212A modem, we have devised a simple and cost effective trouble-free way to evaluate them in a system. Exar can provide you with a modem evaluation kit including these three devices, along with all the necessary supporting components, PC board, schematic and operating instructions to minimize your design task.

1/2 THE COST

Cut Costs, Reduce Space, Improve Reliability

By getting our IC's along with our know-how you make sure your modem will be right.

With our LSI components, you get a modem for about half the money you would normally spend for a finished board and reliability is improved because our LSI circuits reduce the number of necessary parts and the space to house them.

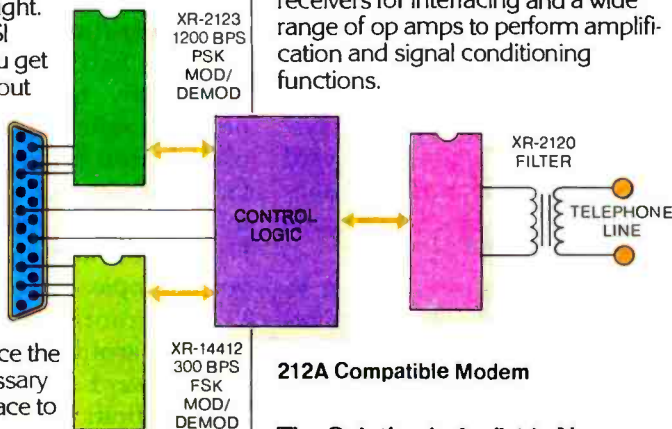

PSK), V.23 (1200/75 BPS FSK) and V.26 (2400 BPS PSK).

To round out a complete design Exar provides RS-232 line drivers and receivers for interfacing and a wide range of op amps to perform amplification and signal conditioning functions.

212A Compatible Modem

The Solution is Available Now

Just send the coupon below or give us a call. You'll get everything you need, including our compilation of modem design and technical data, called the *Modem Data Book*.

So let Exar get your modem design going. Send us the coupon today.

More Modem Solutions

Exar provides modem solutions for a wide variety of applications, from telephone communications compatible with Bell and CCITT standards to high speed transmission over twisted-pair wires. Modem types available included are Bell Standard 103 (300 BPS FSK), 202 (1200 BPS FSK), and 212A circuits as well as CCITT compatible V.21 (300 BPS FSK), V.22 (1200 BPS

Help me make my modem!

- Send me the Exar *Modem Data Book*.
- Also, send me more information about the Modem Design Kit.

Name _____

Title _____

Company _____

Dept./Div. _____

Address _____

City _____

State _____ Zip _____

Phone (_____) _____ Ext. _____

Application _____

EXAR

750 Palomar Avenue
Sunnyvale, CA 94088
Tel. (408) 732-7970 TWX 910-339-9233

For telecommunications, industrial, medical and military IC applications
...EXAR Goes One Step Further.



CP/M Users Group Volume 48: Catalogue and Abstracts," *Lifelines* 1(10): 15-16 (March 1981).

A description and abstract of the BDS C "sampler" disk available from the CP/M Users group. Programs include LIFE, the AWARI game, and a program to "tabify" source code.

26 Cotton, G. "A Master Disk Directory," *Interface Age* 6(11): 104-105, 162-167 (November 1981).

Describes a small-c program for a master disk directory for CP/M systems. Features include wild-card characters and enhanced human-interface characteristics. Source code is given.

27 Datapro. "An Introduction to the 'C' Language," *Applications Software Directory* (Delran, NJ: Datapro Research, 1980).

A reprint and adaptation from *C Notes: A Guide to the C Programming Language* by C. T. Zahn (Yourdon, 1979). Contains a description of C with emphasis on the language's portability. Features examined include syntax, declarations, initializers and statements, machine dependencies.

28 Dobyys, Barry A. "MINCE: Not Just Another Editor," *Dr. Dobb's Journal* 6(4): 48-52 (April 1981).

A review of MINCE, an advanced full-screen editor written in C. The source code for MINCE can be purchased as well.

29 Elliott, Conal. "A Very General Problem-Oriented CAI System," *Behavior Research Methods and Instrumentation* 14(2): 165-169 (April 1982).

A description of a psychology CAI system written in C.

30 Feuer, Alan R. and Narain H. Gehani. "A Comparison of the Programming Languages C and Pascal," *ACM Computing Surveys* 14(1): 73-92 (March 1982).

The authors examine two popular languages—C and Pascal—in terms of their design philosophies, their handling of data types, the programming facilities they provide, and the impact these facilities have on the quality and reliability of programs. Finally,

the authors consider the various types of tasks in which these languages can be applied. C is favored for operating systems and utilities programming. Neither language is deemed suitable for business programming. Pascal is favored in scientific programming because of its greater safety.

31 Fiedler, David, ed. *UNIQUE* (formerly *The UNIX* Software List*) (Info Pro Systems, POB 33, East Hanover, NJ 07936).

A monthly newsletter devoted to news, announcements and analysis of the Unix-C marketplace. Expensive (\$20/year), but it includes news and information not otherwise available. Useful for keeping track of this volatile topic.

32 Fitzhorn, Patrick A. and Gearold R. Johnson, "C: Toward a Concise Syntactic Definition," *ACM SIGPLAN Notices* 16(12): 14-21 (December 1981).

The paradox of C as a systems implementation language vis-à-vis its "vague (and sometimes incorrect)" grammar description is discussed. The authors present a definition of C that incorporates into the syntax many of the semantics currently describing the language. Advantages to this approach include easier compiler implementation and faster compilation.

33 Fitzhorn, Patrick A. "C: Toward a Concise Syntactic Description: Appendix," *ACM SIGPLAN Notices* 17(8): 89-95 (August 1982).

BNF (Backus-Naur-Form) description of the C language in a more readable form than Fitzhorn and Johnson (December 1981).

34 Garrett, Roger C. "Structured English for the 'C' Programmer," *Interface Age* 6(10): 30-34 (October 1981).

Describes an extension to C that allows the expression of algorithms in English-like phrases. Called C.plus, it is useful for the specification of algorithms. Global data references, local data definitions, and structures are all discussed.

35 Garrett, Roger C. "More on 'C' Programming," *Interface Age*

6(11): 26-28, 158 (November 1981).

A continuation of Garrett's description of C.plus (October 1981) dealing with executable statements, unary operators, and shift and increment/decrement operations. Source code included.

36 Garrett, Roger C. "C.Plus (Conclusion)," *Interface Age* 6(12): 34-38, 142-143 (December 1981).

Garrett's concluding article on extensions to C (C.plus), including decision and looping structures. Source code included.

37 Gewirtz, David A. "An Introduction to the C Programming Language," *Microsystems* 2(6): 20-38 (November/December 1981).

An introductory tutorial on C and evaluation of several popular C compilers (BD Software C, small-c, tiny-C Two, and Whitesmiths C). Differences in implementation are noted.

38 Gewirtz, David A. "An Introduction to the C Programming Language (Part II)," *Microsystems* 3(1): 50-58 (January/February 1982).

A tabular comparison of C compiler implementations (see Gewirtz, November/December 1981) and program benchmark tests. Source code for benchmark programs is included. Price-performance leader is BDS C compiler, while Whitesmiths C is the only complete implementation of the language.

39 Gewirtz, David A. "Reply to Larry Hamelin," *Microsystems* 3(4): 12 (July/August 1982).

Gewirtz agrees with Hamelin concerning pointer clarification.

40 Gibson, T. A. and S. B. Guthery. "Structured Programming, C and tiny-C," *Dr. Dobb's Journal* 5(5): 30-33 (May 1980).

Summary of structured programming concepts illustrated with tiny-C. Comparison of tiny-C with standard C.

41 Gilbreath, Jim. "A High-Level Language Benchmark," *BYTE* 6(9): 180-198 (September 1981).

An examination of high-level lan-

NAKED APE

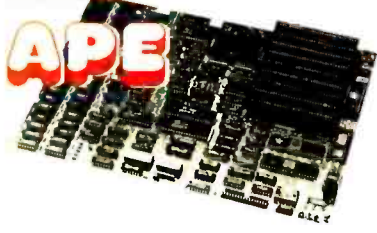

Naked APE Specifications

- 8088 CPU with optional 8087 co-processor
 - 64K to 256K of parity checked RAM.
 - 32K of EPROM space. (Address F8000 to FFFFF)
 - Supports 2716, 2732, 2764, and 27128 EPROMS
 - 4 DMA channels (one is used for refresh)
 - 3 Timer channels (one is used for refresh) with 1.05 micro-second resolution
 - 8 levels of interrupts
 - 1 parallel printer port (centronix)
 - 2 serial ports (8250 UART)
 - IBM compatible keyboard port
 - Speaker port
 - Reset port
 - 5 to 9 IBM compatible expansion slots
 - DOS BIOS included on EPROM
 - Supports MS DOS, CP/M 86 and Quix
 - Small size: 8 1/2" x 12" multi-layered board
 - Operating temperature: 0-55° C
 - Power: -5v @ 3a / -12v @ 50ma / +12v @ 50ma / -5v not required, but may be required by expansion slots.
 - 6 Month Warranty
- 1+ \$650 5+ \$615

NAKED APE SYSTEM

Advanced PC emulator • Motherboard • 2 thinline 320K drives • power supply • Keytronics Keyboard • Graphics Video Card • DOS • Basic • Disk Controller • Add Video Monitor

\$1850

COMPUTERS

Apple II-E Starter System	\$1655
Chameleon by Seega	\$1875
Columbia MPC system w/solt	\$2795
Columbia MPC 10MB w/solt	\$3900*
Columbia VP portable w/solt	\$2750*
Compaq -1 drive	\$2795
Compaq -2 drive	\$3150
CORONA Data Systems—Systems include 320K drives • 128K RAM expandable to 512K • 640 x 325 graphics • green monitor with 16 x 13 matrix characters • serial port • parallel port • DOS, Basic, and software.	
PC-1 1 drive/desk	\$2195
PC-2 2 drive/desk	\$2475
PC-HO 10MByte	\$3795
PPC-1 1 drive/portable	\$2050
PPC-2 2 drive/portable	\$2350
Epson QX-10 w/Valdocs	\$2495
Franklin ACE1000 w/color	\$925
Franklin ACE 1000 system	\$1295*
Franklin ACE1200	\$1625
IBM PC system	\$2650
IBM XT system	\$5300
Kaypro II	\$1475
Kaypro IV	\$1895
Morrow M02 w/solt	\$1145*
Naked APE—motherboard	\$650*
Naked APE System	\$1850*
NEC PC8800	\$995*
NEC APC HD1	\$2250
Osborne double density	\$1435
Osborne Executive	\$2295*
PIED PIPE 784K drive, software	\$1055*
Silfiline S-100: Z-80, CP/M, 2MByte drives, 64K	\$1955

TASKMASTER FOR IBM

SOFTWARE TO RUN 9 JOBS

Simultaneously

NOT \$900 NOT \$350 JUST \$125

"Do you want low price or high performance?"

IRONSIDES prices are so low YOU CAN AFFORD higher performance.

* Indicates New Item

FOR IBM PC

Anrok 6 Slot Expansion Cabinet	\$435*
AST I/O-II S/G/C	\$149
AST ComboPlus 64K/S/P/C	\$265
AST MegaPlus II 64K/S/P/C/G	\$305
AST MegaPak 256K for MegaPlus	\$265
dBase II for PC-DOS	\$429
Hayes Smartmodem 1200B w/solt	\$455*
Hercules 720 x 350 graphics	\$445*
JCS RGB-III 640 line, with Cable	\$395
Lotus 1-2-3	\$335
Keytronics Keyboard	\$195
Monte Carlo 64K, Serial, Parallel, Clock, Game	\$255*
Princeton HX-12 RGB with Cable	\$495
Quadlink (Apple converter)	\$495*
RAM Sets 64K with parity	\$62
Rixon PC212A modem	\$375
Shugart Thin 320K drive #SA455-2	\$245*
Sysgen II-10 (10Mb with Backup)	\$2250*
Sysgen II-20 (20MB with Backup)	\$3100*
Sysgen Image (Backup)	\$875*
Tandon TM100-2	\$245
Tandon 10MB hard disk system	\$1250*
USI multidisplay Card	\$345*

FOR ATARI

Rana Elite 1000-single/double density floppy	\$385
Rana double density software	\$45

MASTER FLEX DISKETTES

We private-labeled the best brand, 5 year warranty, 5 1/4", soft sector, hub ring, 10 per box.			
SS00	\$20/BOX	5 QTY=\$18/BOX	
OS00	\$27/BOX	5 QTY=\$25/BOX*	

FOR OSBORNE

OSMOS 1—double density mod	\$175
OSMOS 4-20 format read/write	\$215
OSMOS 5-80 column adapter	\$235

VIDEO MONITORS

Amdek 300G	\$142
Amdek 300A	\$165
Amdek 310A amber for IBM	\$185
Amdek Color I... We recommend BMC Composite 13"	\$275
Amdek Color II w/PC cable	\$435
BMC 13" Color (BM-AU9191U)	\$275
BMC 13" RGB with card for Apple II*	\$395
Dynax 12" Green (GM-130) 20MHz	\$129
Dynax 12" Amber (AM-121) 970 line resolution!	\$145
JCS RGB-III with cable-PC	\$395
Princeton HX-12 RGB for PC	\$495
Taxan 12" Amber	\$159
Taxan Vision-III (PC or Apple)	\$535
Taxan Apple II-E interface w/80 column	\$145
USI PI-1 9" G	\$126*
USI PI-2 12" A	\$137*
USI PI-3 12" A	\$147*
USI PI-4 9" A	\$137*

MICROPRO SPECIALS

FOR APPLE: WORDSTAR & CP/M

LIST...\$495 NOW...\$295

FOR APPLE: INFOSTAR & CP/M

LIST...\$495 NOW...\$295

FOR IBM-PC, APPLE, & ALL CP/M:

WORDSTAR/SPELLSTAR/MAIL

MERGE/STAR INDEX

LIST...\$895 NOW...\$395

EPSON

FX-100 • 160 cps draft • 80 cps correspondence • 15" wide paper • friction • sprocket • graphics

\$745

FOR APPLE & FRANKLIN

ALS CP/M Card-64K, CP/M 3.0	\$295
AMDISK 1 3" disk, 286K, uses std. controller	\$285
16K RAM Card	\$55
80 COLUMN Card for II* & Franklin	\$95
80 COLUMN with 64K-for II-E	\$145
dBase II (requires CP/M)	\$419
Davong 10 MByte hard disk—BEST BUY	\$1695
Quomplng 16K—graphics and buffer, expandable	\$160
Grappler*	\$125
Graphics Interface with Cable	\$85
Hayes Micromodem II with MICROPRO Package	\$295
INFOSTAR with CP/M—MICROPRO Package	\$295
Microsoft MULTIPLAN	\$190
Rana Elite One—still the best	\$275
Rana Elite One Plus—with controller	\$355
Rana Elite Two—double storage	\$435
Rana Elite Three—quad storage	\$555
Serial Interface	\$105
SSM Modemcard w/SOURCE	\$285
VISTA QUARTET (2 drives, thin, 640K, controller)	\$685
WORDSTAR with CP/M—MicroPro package—	
list \$495	\$295
Z-80 CARD	\$115

MODEMS

Hayes Smartmodem 300	\$215
Hayes Smartmodem 1200—outsells the rest	\$515
Novation J-CAT	\$110
Novation 103/212 SMART (direct connect)	\$385
Novation 103 SMART (direct connect)	\$179
RIXON R212A-300/1200 SMART	\$365

PRINTERS

Brother HR-1A 17cps daisy	\$695
Brother HR-15	\$555*
Epson MX-80FT	\$475
Epson FX-80	\$565
Epson FX-100	\$745*
F-10 Starwriter 40cps	\$1145
F-10 Printmaster 55cps	\$1495
Gemini-10X 120 CPS, Epson compatible	\$295
Gemini-15 wide carriage friction/tractor/graphics	\$429
IDS Microprism	\$495
IDS PRISM 80, all options	\$1275
Mannesmann-Tally 160L with tractor	\$645
Mannesmann-Tally 180L wide	\$870*
NEC 3550	\$1865
NEC 7730	\$2145
Okidata... uses standard spool type ribbons	
u82A... serial/parallel/friction/sprocket	\$405
u83A... wide	\$615
u92... 160cps, 80 column, parallel	\$495
u93... 160cps, wide	\$895
Prowriter (C. Itoh 8510A)... 120cps, proportional	\$372
Prowriter II (C. Itoh 1550A)... wide carriage	\$665
RITEMAN with tractor	\$385*
TTX1014 13cps daisy, serial, parallel	\$485*

Verify prices by phone. Add 2% for Visa or MasterCard. Add 6 1/2% on California orders. Orders prepaid with check, cashiers check, money order or wire transfer are shipped prepaid within the Continental U.S. COD's require 10% non-refundable deposit (re-stocking fee).

IRONSIDES COMPUTER CORP

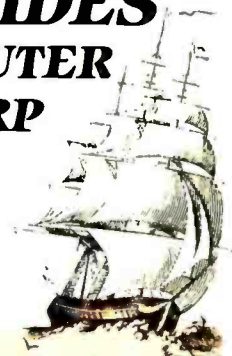

**Customer Service—
Product Selection Advice
(213) 344-3563
ORDERS (800) 528-9537
18905 Sherman Way
Reseda, CA 91335**

Visit our new, enlarged showroom.

guage performance using the Sieve of Eratosthenes algorithm on both micro- and mini-based systems. Source code is included for all languages. PL/I-80 rates highest in execution speed, surpassing Whitesmiths C by approximately 10%. Other Cs evaluated include BD Software C and tiny-C. Note that versions of BDS C include a modified Sieve program that would place it just below PL/I-80 in speed.

42 Gilbreath, Jim and Gary Gilbreath. "Eratosthenes Revisited: Once More Through the Sieve," *BYTE* 8(1): 283-326 (January 1983).

An excellent update and revision of the earlier Gilbreath article (*BYTE*, September 1981) on the Eratosthenes Sieve program as a benchmark for several languages. After presenting normal timing data, the authors also show the effect optimizing can have on benchmark speed. A second benchmark is presented that exercises the computer's operating system—language interface. The authors make two very interesting observations concerning C: first, that "the degree of compatibility among the C compilers is remarkable" (as they note, no C standard exists); second, that "programming in C is fun, like driving a small car." All in all, this is an excellent article on this specific benchmark and the whole benchmark approach. Source code for benchmarks is included.

43 Hamelin, Larry. "Intro to the C Programming Language," *Microsystems* 3(4): 12 (July/August 1982).

Note to the editor concerning ambiguity in the description of pointers in the Gewirtz series (see David Gewirtz's articles).

44 Hancock, Les. "Growing, Pruning and Climbing Binary Trees with tiny-C," *Dr. Dobb's Journal* 4(5): 37-41, 54 (May 1979).

The use of tiny-C in implementing a complex data structure (here, binary trees) is shown. Extensive use and discussion of pointers. Source code is included.

45 Hancock, L. "Implementing a Tiny Interpreter with a CP/M-

flavored C," *Dr. Dobb's Journal* 5(1): 20-28 (January 1980).

Presents the implementation of a simple interpretive language on CP/M using the BDS C compiler. Useful discussion of the parts of an interpreter. Source code is included.

46 Hendrix, J. E. "Small-C Expression Analyzer," *Dr. Dobb's Journal* 6(12): 40-43 (December 1981).

Patches for three problems with the address arithmetic in the small-c expression analyzer are given.

47 Hendrix, J. E. "Small-C Compiler, v. 2," *Dr. Dobb's Journal* 74: 16-52 (December 1982).

Improved version of the classic small-c compiler (see Ron Cain's articles for details of the original). Improvements include code optimization, data initialization, compiler directives, and numerous others. (Hendrix lists 18 new features.) An excellent starting point for any C software hacker. Full source code is included. This series is destined to the same fame accorded the original small-c.

48 Hendrix, J. E. "Small-C Compiler, v.2 Continued," *Dr. Dobb's Journal* 75: 48-64 (January 1983).

Continuation of the source code listing for a new, improved small-c. Details of the compiler can be found in Hendrix's December 1982 article.

49 Hogan, W. L. "An Evaluation of a Raster Scan Display for Use in an Aircraft Information Handling System" (Master's thesis, Naval Postgraduate School, Monterey, CA, 1977). Information system written in C.

50 Howard, J. E. "An Implementation of a Codasyl Based Data Base Management System Under the UNIX Operating System" (Master's thesis, Naval Postgraduate School, Monterey, CA, 1978).

Data handling features of the system are written in C.

51 Hughes, Phil. "BASIC, Pascal or Tiny-C? A Simple Benchmarking Comparison," *BYTE* 6(10): 372-375 (October 1981).

The author uses a simple "card-shuffling" benchmark program to test three popular microcomputer lan-

guages. Tiny-c fares poorly, but see *BYTE*, September 1981 (pp. 180-198) for benchmarks of other compilers (BDS, Whitesmiths, tiny-C II).

52 Jackson, T. R. "Letter to the Editor," *Microsystems* 3(5): 22-23 (September/October, 1982).

This letter notes several problems in David Gewirtz's article series on C compilers.

53 Johannson, Jan-Henrik. "Argc and Argv for Small-C," *Dr. Dobb's Journal* 74: 62-64 (December 1982).

An enhancement to the Code Works version of small-c to implement command-line arguments and I/O redirection.

54 Johnson, S. C. "A Portable Compiler: Theory and Practice," in *Proceedings 5th ACM Conference on Principles of Programming Languages* (1978).

A technical discussion of the design considerations in the first C compiler.

55 Johnson, S. C. and D. M Ritchie. "Portability of C Programs and the UNIX System," *Bell System Technical Journal* 57 (6; pt. 2): 2021-2048 (July/August 1978).

Discusses the theory behind the C features that enhance program portability. Case study presented with transfer of programs from DEC to Interdata systems. (See Gilbreath and Gilbreath, January 1983, for examples of portability on microprocessor C systems.)

56 Joyce, J. "Review of *The C Puzzle Book*," *ACM Computing Reviews* (June 1982): 286.

Contains a brief review of *The C Puzzle Book* (see Alan Feuer, 1982) suggesting that it can be useful in exploring interdialect differences in C implementations.

57 Kern, Chris. "A User's Look at Tiny-C," *BYTE* 4(12): 196-206 (December 1979).

Includes extensive favorable analysis and review of the tiny-C interpreter. Highlights the program preparation system (written in tiny-C itself), as well as the differences between C and tiny-C. Commends tiny-C for superior documentation. Includes tiny-C program sample with explana-

WHY DEC AND INTEL CHOSE THE MARK WILLIAMS C-COMPILER.

DEC and INTEL wanted the best C technology available, with excellent code density, supporting the full C language and their specific operating environments—all at a competitive price.

They found it all at Mark Williams.

WHY YOU SHOULD CHOOSE THE MARK WILLIAMS C-COMPILER.

Our C-compiler supports the dominant 16-bit micro-computers—68000, PDP-11*, Z8000, 8086—with a proven reliable, high-technology product. We are shipping versions of C for a large number of environments including CP/M* and PC DOS.* Both cross and native compilers are available.

Call us for the distributor nearest you. OEM's should contact us directly about their specific requirements.

Mark Williams Company
1430 West Wrightwood, Chicago, Illinois 60614,
312/472-6659



*PDP-11 is a trademark of Digital Equipment Corporation.

*CP/M is a trademark of Digital Research Corporation.

*PC-DOS is a trademark of IBM.

Circle 422 on inquiry card.

tion.

58 Kern, Christopher. "Printf for the C Function Library," *BYTE* 6(5): 430-434 (May 1981).

An enhancement to early versions of BDS C that allows the very useful printf to be used in output processing. Allows printing of numerical data in octal as well as variable precision. Source code and sample program using the function are included.

59 Kern, Christopher. "The BDS C Compiler," *BYTE* 6(6): 356-362 (June 1981).

A product review of the BDS C Compiler that notes the power and conciseness of C vis-à-vis Pascal. Includes a comparison of C and Pascal aimed at those "not ideologically committed to the proposition that Pascal is the most congenial programming language." The only complaints are with lack of floating-point (available in library functions) and redirection of I/O (also included in later versions as library functions).

60 Kern, Christopher. "MINCE: A Text Editor," *BYTE* 6(9): 150-160 (September 1981).

A product review of the MINCE (MINCE Is Not Complete EMACS) editor, which is written in BDS C. Useful features noted include multifile capabilities as well as the ability to modify the editor to one's own needs. MINCE is a good example of the power of BDS C. One major complaint is that MINCE is slow. Kern commends MINCE for excellent documentation.

61 Kern, Christopher. "Microshell and Unica: Unix-style Enhancements for CP/M," *BYTE* 7(12): 206-219 (December 1982).

A product review of two Unix-style operating shells for CP/M. Both Microshell and Unica are considered to be useful enhancements to CP/M by increasing the system's flexibility and user friendliness. Note is also made that MARC is a complete operating system, not simply a CP/M enhancement.

62 Kern, Christopher O. "The Scribble Text Processor," *BYTE* 8(2): 302-309 (February 1983).

A product review of the Scribble text

processor. The companion processor to the MINCE text editor, SCRIBBLE may be described as a high-level language for text manipulation. As with other Mark of the Unicorn products, documentation is superb (100-page user manual and a comprehensive program logic manual). Kern notes that SCRIBBLE is best when processing large, complex documents.

63 King, B. "The Flexibility of C," *CP/M Review* 1(2): 22-23, 75 (January/February 1983).

Brief and accurate discussion of C's features by an author "who refuses to work at a company that doesn't use C."

64 Krieger, M. S. and P. J. Plauger. "C Language's Grip on Hardware Makes Sense for Small Computers," *Electronics* (May 8, 1980).

The authors (both of Whitesmiths and one of *Software Tools* fame) describe C and its use in small-computer environments where portability between processors is important. Useful presentation of pointer arithmetic is included, as well as a description of Whitesmiths A-Natural code (a narrative type of assembler code). As the authors conclude, "It is ironic that the ability to write very machine-dependent code with C has encouraged its portability. By filling the gap between assembly language and traditional high-level languages, C has succeeded in wooing numerous converts from both camps."

65 Libes, Don. "Reply to T. R. Jackson," *Microsystems* 3(5): 23-26 (September/October 1982).

A reply to Jackson's letter noting typographical and other errors in David Gewirtz's series of articles on C compilers (see T. R. Jackson, September/October 1982).

66 Madden, J. Gregory. "C: A Language for Microprocessors?" *BYTE* 2(10): 130-138 (October 1977).

An early (dark ages of 1977) article extolling the virtues of C with a tutorial presentation of its primary features. Notes I/O capabilities and control structures. Written before any micro-computer Cs existed, the article concludes with a hopeful "wait and C."

Today, one need simply "look and C." 67 Mark of the Unicorn, *MINCE Text Editor Documentation* (Mark of the Unicorn, 1981).

While it might seem unusual to include a user manual for a specific text editor in a bibliography on the C language, my reasons are many. First, MINCE is written in C, specifically BDS C, and includes details on how to customize the editor using the C language. Second, this manual is the finest technical manual I have ever seen. It even includes a section (of some 50 pages) that discusses the consideration involved in implementing any text editor. Mark of the Unicorn is to be commended for using C and providing means for software modification. MINCE is highly recommended as an excellent example of a complete system. (See Christopher Kern's articles for reviews of the entire Mark of the Unicorn's text system—MINCE/SCRIBBLE.)

68 Mateti, Prabhaker. "Pascal Versus C: A Subjective Comparison," in *Proceedings of the Symposium on Language Design and Programming Methodology* (Sydney, September 10-11, 1979); pp. 37-69.

Discusses Pascal and C, noting that both possess comparable data and control structures. The program structure of C is considered superior, although the power and ambiguity of C also pose dangers to the programmer. C's powerful features are counterbalanced by its tendency for obscure code. As Mateti notes, "Excellent programs can be written in either language. . . . I am concerned that it is all too easy to write incomprehensible programs in C."

69 McSkimin, J. R. "REDAS—A Relational Data Access System for Real-Time Applications," in *Proceedings of COMPSAC 1978* (Computer Software and Applications Conference, 1978).

Interpretive database retrieval system written in C.

70 Meissner, Michael. "Letter to the Editor," *ACM SIGPLAN Notices* 17(8): 84-88 (August 1982).

Contains an extensive commentary

UNBELIEVABLE!

XCOMP sat down to design a truly distributed IBM network so versatile and complete that it would satisfy any user's needs.

It seems too good to be true, but we did it!

X-NET is so advanced that it can only be imitated. It has all the features of standard networks and many more. And, because it is **not dependent on a central file server** you save the high cost of that hardware.

Call our sales department today for complete details on X-NET. The exclusive network of PC-DOS 2.0!

X-NET

A Network Superset of PC-DOS 2.0

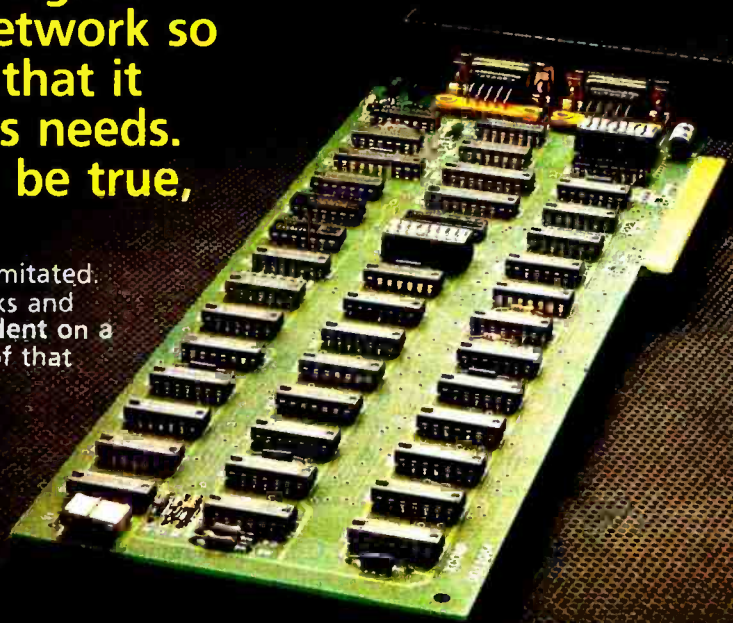

Other quality products available from XCOMP.

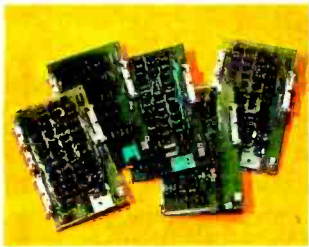

CONTROLLERS

XCOMP manufactures a complete line of controllers for all popular drives. The X/R Series is a controller for 3 to 300 megabyte drives.

We also produce a \$100 controller package. A microprogrammable data board is common to each package and operates with a second drive interface board. Buffer size is 256 bytes, with disk data rate up to 10MHz.



HARD DISK SUB-SYSTEMS

10 megabyte and 16 megabyte hard disk sub-systems for the IBM PC, Apple II and III and nearly all popular personal computers.

XCOMP sub-systems are 2 to 3 times faster than many of the competition's and come complete with our extensive software.

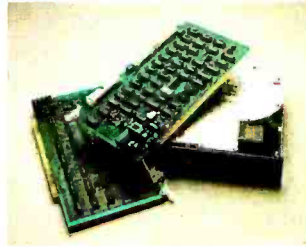

PACKAGE DEALS

Exceptional prices on 10 and 16 megabyte formatted drives and controllers. The ST/5 for 5100 computers and the ST/R for single board computers. An optional Z-80 adapter allows for simple plug-in convenience. Optional equipment includes software, cables and cabinetry.



THE TOASTER

THE TOASTER is a hard disk sub-system containing TWO REMOVABLE 3.9", 5 megabyte cartridges. THE TOASTER provides unlimited storage and convenient back-up with total portability. Speed and reliability are a given.

THANK YOU FOR YOUR OVERWHELMING RESPONSE!
We are substantially back-ordered on TOASTERS. We appreciate your patience!

Circle 428 on inquiry card.

Apple, Apple II and Apple III are trademarks of Apple Computer, Inc.
IBM and IBM PC are trademarks of International Business Machines Corporation



© 1983, XCOMP, Inc.

XCOMP, Inc., 7566 Trade Street, San Diego, CA 92121, (619) 271-8730, Telex 182786

www.americanradiohistory.com

on the Fitzhorn and Johnson article (December 1981). Clarification of the comma (,) operator in C, as well as such features of C as sizeof, arithmetic if, and types are included. Should be read in conjunction with Fitzhorn and Johnson.

71 Mohler, Lorin S. "A Disk Alignment Routine," *Microsystems* 2(6): 70 (November/December 1981).

A disk-alignment routine for Tarbell single-density drives written in BDS C. Source code is included.

72 Ness, David and A. Krigman. "MINCE Editor from Mark of the Unicorn," *Infoworld* (May 11, 1981).

A favorable review of MINCE with special emphasis on its capacity for large file manipulation tasks and user extensibility and modification. A typically thorough *Infoworld* review.

73 Norris, Bill. "C-Bits (All About BDS C version 1.45)," *Lifelines* 2(9): 37-38 (February 1982).

A note briefly describing the bug fixes, new features, the new linker, and the file sieve.doc (benchmarking program).

74 *Pipes and Filters* (publication of Uni-Ops, POB 582, Walnut Creek, CA 94596-1182).

A newsletter/journal for Unix, C, and Software Tools news and trends. A useful guide to the expanding C field. (See David Fiedler for a similarly useful newsletter.)

75 Plauger, P. J. "Review of *The C Programming Language*," *ACM Computing Reviews* (January 1979): 2-4.

Plauger considers C to be "one of the important contributions of the decade to the practice of computer programming" and notes that Kernighan and Ritchie's book is the definitive treatise on the subject. Although the reviewer is concerned over consistency of presentation, this is, all in all, a very favorable recommendation of the "C bible."

76 Pournelle, Jerry. "User's Column . . . MINCE Is Not Complete EMACS," *BYTE* 7(7): 294, 298, 300 (July 1982).

Pournelle reviews MINCE unfavorably, although he admits his own prejudice. He notes the good

features of MINCE, but specifically also dislikes MINCE's habit of telling the user "things I don't want to know." Concludes by saying that others like MINCE.

77 Pournelle, Jerry. "User's Column . . . There's a New C A'comin'," *BYTE* 7(12): 230, 235, 236 (December 1982).

Includes a brief mention of the major C compilers available. The software developers' addresses are given along with brief evaluations.

78 Pugh, T. J. "MCALL-C: A Communications Protocol for Personal Computers," *Dr. Dobb's Journal* 5(2): 16-20 (June/July 1980).

Communications software written in C.

79 Pugh, Tim. "BDS C, A Full Compiler from Lifeboat Associates," *Infoworld* (March 31, 1980).

Contains a review of the BDS C compiler with comparisons to Whitesmiths full C compiler. Concludes that BDS C could use improved error-handling capabilities but that in terms of price-performance ratio, BDS C is an excellent product.

80 Reed, Adam. "An Underline Filter for Matrix Printers," *BYTE* 7(3): 300-306 (March 1982).

The author presents a program in C that sets the half-line spacing option for DECwriter printers, thus allowing fast, legible underlining of text. This is a useful example of the power of C in system utility writing. Source code is included.

81 Reid, Larry and Andrew P. McKinlay. "Whitesmiths C Compiler," *BYTE* 8(1): 330-344 (January 1983).

An excellent discussion of the "cadillac" of C compilers, Whitesmiths C, which features full Unix version 7 compatibility. The inclusion of I/O redirection and command-line arguments makes the user interface for Whitesmiths C programs much more friendly. With Unix 7 compatibility, Whitesmiths C programs are extremely portable (however, note the Gilbreaths' comments on the ease of portability in all Cs). Whitesmiths' documentation is excellent and the

system is heartily recommended by the authors in spite of its high cost (about \$550).

82 Reitz, Randy. "Small-VOS and Small-Tools," *Microsystems* 4(1): 66-69 (January 1983).

This article describes the use of small-c to implement 14 of the text-processing programs inspired by the book *Software Tools* by Kernighan and Plauger. A short section is also devoted to a discussion of small-c itself.

83 Ritchie, D. M., S. C. Johnson, M. E. Lesk, and B. W. Kernighan. "The C Programming Language," *Dr. Dobb's Journal* 5(5): 20-29 (May 1980).

The authors present an overview of the semantics and syntax of C. The strengths and weaknesses of the language are discussed, with the authors concluding that C is likely to remain a high-level assembly-language replacement into the far future. Useful discussions of the C pre-processor, pointers, and derived types are included. A highly recommended article (reprinted from *Bell Systems Technical Journal*; see below).

84 Ritchie, D. M., S. C. Johnson, M. E. Lesk, and B. W. Kernighan. "UNIX Time-Sharing System: The C Programming Language," *Bell Systems Technical Journal* 57(6): 1991-2019 (July/August 1978).

An article from the source of C itself describing the language, its power, and its problems. Note that there are some discrepancies between this article and *The C Programming Language*, Appendix A. Only the latter should be considered the definitive description of the language. This article has been reprinted in *Dr. Dobb's Journal* "C Issue" (May 1980) and is highly recommended.

85 Robertson, M. D. "An Extended BASIC Compiler with Graphics Interface for the PDP-11/50 Computer" (Master's thesis, Naval Postgraduate College, Monterey, CA, 1977).

BASIC compiler written in C to run under the Unix system.

86 Rovegno, H. D. "Using C Language for Microprocessors," in *Electro/77 Conference Record* (1977).



**Victor.
How a first name
can make it
big in the
business world.**

What does it take these days to be successful?

First, speak several languages. Have a large and infallible memory. Adapt at lightning speed. Stay accessible 24 hours a day. Be practical. And, above all, remain simple and inexpensive.

That's exactly why Victor® is a leader. The leading 16-bit microcomputer in Europe.

Start with the fact that Victor speaks virtually all Western languages. Fluently. And, you can adapt Victor's keyboards to either language or business specific applications.

Then, Victor has a large and useful memory. That's vital.

And Victor is highly flexible and adaptable. With appropriate software, Victor can perform thousands of jobs at electronic speed. In fact, Victor's extensive software library allows you to put Victor to work in your office, department or plant immediately. Productively.

Finally, Victor is cost-conscious. When it comes to price and performance, you can't buy more computer for less.

A success in the business world? Absolutely. To find out how a first name can make it big in your business, contact Victor at the address or phone number below.

Circle 411 on Inquiry card.

VICTOR®
The computer you call by name.
VICTOR TECHNOLOGIES INC. P.O. BOX 9601, MISSION HILLS, CA 91346.
1-(800) VIC-9000; IN CALIFORNIA, (800) 441-2345, EXTENSION 51.
VICTOR TECHNOLOGIES EUROPE, NINOOFSESTEENWEG 71, 1730 SCHERPEAAL, BELGIQUE (2)569.55.00.

"It would be hard to find a more powerful or sophisticated desktop computer within the price range of the Sanyo"

Infoworld - 11/29/82



Just Added:
Self-Teaching
Disk.

\$1995



SANYO PLUS



A full feature, fast, Z-80, 64K computer with over \$2000 of software for \$1995.

The Sanyo Plus hardware includes a Sanyo MDC-1000 computer with a built-in 12" high-res. green phosphor 25x80 display, a serial communications port and a parallel printer port. The detached keyboard is sculpt and tiered and includes a separate 10-key pad.

The Sanyo Plus has dual 5 1/4" double density drives and features a total formatted disk capacity of 624K.

The Sanyo Plus software includes CP/M[®], Basic and the unabashed, top-dog Micropro application programs: Wordstar, with training guide, Mailmerge, Spellsrar, Calcstar, and the new Infostar package including Datastar and Repostar.

Plus we add a 300 baud direct connect modem with cable, modem software, and a games disk. Plus we integrate and test your system and include work copies generated on your system.

For more information call us at Scottsdale Systems. (No Dealers Please)

One year warranty \$99. Five module business software pack \$99. One drive system \$1649. Hard disks: 10Mb-\$1995/16Mb-\$2395.

Coming Soon: Sanyo Plus with graphics.

TELEVIDEO

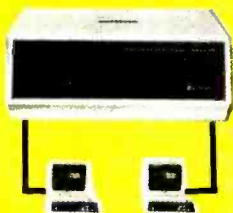

Buy a Televideo multi-user system from us at discount and we'll arrange on-site installation in any of 55 U.S. cities via TRW (additional charge). You can start with the single-user 803 and expand to a 16 user multi-tasking, multi-user network.

803	Call
1603	Call
802H	\$4529
806/20 Mb	\$5111
816/40 Mb	\$9210

ALTOS



Our tech's favorite systems. From the lowest priced 3-user systems with either 2 or 8 MG. storage to 40MG. 8-user 16 bit systems.

Add terminals, printers, and software and we can fully test and configure your system at low prices. Back nationwide by Moore Systems Service.

5-15D	\$2175
5-80-10	\$4695
8000-10	\$5444
16 Bit Systems	Call
Series 5, 8000, systems include MP/M	

ZENITH



New low prices on the systems that are 5-100 16 bit/8 bit, MS DOS and CP/M compatible. Plus they're backed by Zenith service virtually everywhere. The Z-100's feature two built-in 5 1/4" drives, 128k RAM, and 225x640 graphics. Add a 13" RGB ZVM-134 monitor to your 110 for superior color display.

ZF-110-22	\$2699
monitor	\$2799
ZF-120-22	\$2799
ZVM-134 (color)	\$555
ZW-110-32 (11.3Mb)	\$4249

COLUMBIA



If you've been waiting for a great deal on an IBM-like wait no longer. The Columbia VP is a 38 lbs. portable with a 9" green screen and dual 320K drives. Comes standard with MS-DOS, CP/M-86, Basic (with IBM PC compatible color graphics), Macro Assembler, Async communications, Perfect Writer[™], Perfect Speller[™], Perfect Calc[™], Perfect Filer[™], Fast Graphs[™], Home Acc't Plus[™], Space Commanders, Diagnostics and Columbia Tutor. Plus they're backed nationwide thru Dell & Howell

\$2349.00

TERMINALS



Adds Viewpoint 3A+ - Emulates the ADM-3A, detached keyboard, keypad, 12" green display, nationwide Adds service.

\$469.

Wyse 100	\$694
Wyse 200	\$1049
Televideo 910	\$579
Televideo 925	\$735
Televideo 950	\$927
Televideo 970	\$1044
Zenith Z-29	\$659
Zenith ZTX	\$349
Zenith ZT-1	\$446
Espirit II	\$544
Ampex D175	
Amber	\$699
Qume 102	\$544

Houston Instruments: DMP-40...\$745, DMP-29...\$1795, DT-11A...\$789

PRINTERS



Gemini 10X	\$288
Gemini 15	\$444
NEC 8023A	\$398
Tally 160L/trac	\$584
Tally 180L/trac	\$799
IDS Microprism	\$509

HIGH SPEED

Anadex 9620A	\$1399
Qantex 7030	\$1562
TI-810	\$1285
Prism 132	
"loaded"	\$1469
Prism 80	
"loaded"	\$1369

LETTER QUALITY

Sonyo PR5500	call
Silver Reed 550	\$654
550-Serial	\$695
NEC 3510	\$1411
NEC 7710	\$2099
DTC 380Z (48K)	\$1044

Scottsdale Systems Ltd.

617 N. Scottsdale Road, Suite B, Scottsdale, Arizona 85257

 (602) 941-5856 MasterCard

Call 8-5 Mon.-Fri.



We participate in arbitration for business and customers through the Better Business Bureau of Maricopa County.

SERVICE/ORDERING

INTEGRATION: Prices listed are for new equipment in factory sealed boxes with manufacturer's warranty. We will pretest your equipment, integrate your system, configure your software, provide special cables, etc. for an additional charge. Call for prices.

ORDERING: MAIL ORDER ONLY. Prices listed are for cash. No C.O.D.'s. We sell on a net 20 basis to Fortune 1000 companies and Universities with good credit. Charge cards add 2%. Prices subject to change, product subject to availability. AZ. residents add 6%. Personal checks take 3 weeks to clear. 0-20% restocking fee for returned merchandise. Shipping extra - products are F.O.B. point of shipment. CP/M and MP/M are registered trademarks of Digital Research.

SOFTWARE: We sell all popular CP/M[®] programs at discount. Software sold only with systems not warranted for suitability.

OKIDATA



The new Microline 92's and 93's feature 160 C.P.S. draft mode, 40 C.P.S. correspondence mode. Standard parallel, serial card add \$91.

Microline 92	\$489
Microline 82	\$389
Microline 93	\$835
Microline 84	\$969

SILVER-REED EXP 500

The latest in low priced letter-quality printers, 14 CPS (Shannon text), Selectable 10, 12, 15 pitch, Std. parallel interface.

\$555



A description of C with particular emphasis upon good documentation practice.

87 Rovegno, H. D. "A Support Environment for MAC-8 Systems," *Bell Systems Technical Journal* 57(6; pt. 2): 2251-2264 (July/August 1978).

A description of the support packages available for the Bell System's MAC 8 microprocessor system that is optimized for C.

88 Runyon, John. "Review of C Notes: A Guide to the C Programming Language," *DEC Professional* (November 1982): 22-26.

Runyon considers the book *C Notes* by C. T. Zahn to be an excellent reference manual to use as a supplement to Kernighan and Ritchie. He estimates C to be a more "universal" language than either COBOL or FORTRAN.

89 Saloman, F. A. "Software Development for Microprocessors—A Case Study," *Proceedings of COMPSAC 1978* (Computer Software and Applications Conference, 1978).

A case study of the use of C in a traditional assembly-language application, a communications switching network.

90 Sethi, Ravi. "A Case Study in Specifying the Semantics of a Programming Language" in *Proceedings 7th Annual ACM Symposium on Principles of Programming Languages* (Las Vegas, NV, January 28-30, 1980); pp. 117-130 (ACM, 1980).

A very technical study of C using denotational semantics.

91 Skjellum, A. "Argnum—A 'C' Command Line Processor," *Dr. Dobbs Journal* 70: 10-31 (August 1982).

An enhancement package to BDS C to simplify the process of command line argument interpretation. Complete source code is included and it appears to be easily modifiable and portable.

92 Skjellum, A. "Using C Instead of Assembly Language," *Microsystems* (5): 33-36 (September/October 1982).

Skjellum argues that C can be a replacement language for the tradi-

tional assembly-language systems programming tasks. Features are presented (e.g., pointers, program structure, local variables) that make C a powerful language for systems work.

93 Springer, Allen. "A Comparison of Language C and Pascal," Technical Report G320-2128 (IBM Cambridge Scientific Center; Cambridge, MA, 1979).

Another general comparison of C and Pascal.

94 Stankowski, J. B. "The Design and Implementation of a General Purpose Interactive Graphics Subroutine Library" (Master's thesis, Naval Postgraduate College, Monterey, CA, 1976).

A subroutine library in C for use under Unix in graphics processing.

95 Stroustrup, Bjarne. "Classes: An Abstract Data Type Facility for the C Language," *ACM SIGPLAN Notices* 7(1): 42-51 (January 1982).

A technical article that describes the construction of a new data type facility in C, the *class*. This construct can be used to restrict access to a data structure or to a specific set of functions associated with it. *Class* is defined in the standard C language and source listings are provided. Difficult reading, but an interesting example of C's extensibility.

96 Taylor, Jeff. "LIST—A Source-Listing Program for the C Language," *BYTE* 6(6): 234-246 (June 1981).

A system utility written in Whitesmiths C that provides source listing outputs for compiler error listings and which uses RT-11 system-specific date routine for heading. Source listing included and should be adaptable (without DATE) to other processors and Cs.

97 tiny-C Associates. "BDS Software C Compiler" (tiny-C Associates pamphlet, n.d.).

Description of BDS C compiler.

98 Ward, Robert, ed. *C Users Group Newsletter* (formerly, *BDS C Users Group Newsletter*). (C Users Group, POB 287, Yates Center, KS 66783).

An occasional publication directed to

all users of the C language in any form. Emphases include notes of C Users Group disks of public-domain C programs, as well as technical information of interest to users of any version of C. Essential for all C users.

99 Whitesmiths *C Programmers' Manual* (Whitesmiths Ltd., 97 Lowell Rd., Concord, MA 01742).

A four-part manual describing the Whitesmiths C implementation with sections on run-time library portability issues.

100 Whitesmiths *The C Letter* (Whitesmiths; three issues per year).

Publication by Whitesmiths for users of its C language implementation.

Index

I. General and Introductory C Materials:
01, 02, 03, 04, 05, 06, 07, 11, 27, 37, 38, 40, 43, 52, 63, 64, 65, 66, 77, 83, 84, 88, 92, 97

II. Reviews

A. C compilers:

1. BD Software C (BDS C), 10, 37, 38, 59, 73, 77, 79, 97, 98
2. C.plus, 34, 35, 36
3. Small-c, 20, 21, 37, 38, 47, 48, 82
4. tiny-C, 37, 38, 40, 44, 51, 57, 77
5. Other C versions 45, 77, 81, 99, 100

B. C-based editors and text processors:

1. Ed Ream editor, 22
2. MINCE/SCRIBBLE, 17, 23, 24, 60, 62, 67, 72, 76

III. Benchmarks and Comparisons

A. Benchmarks:

41, 42, 51

B. Comparisons of C with Pascal:

30, 41, 42, 51, 68, 93

IV. Applications/Techniques

using C (hobbyist), 17, 20, 21, 26, 34, 35, 36, 44, 46, 47, 48, 53, 58, 71, 78, 80, 91, 92, 96

V. Applications/Techniques using C (advanced), 08, 09, 12, 13, 14, 15, 16, 18, 19, 29, 32, 33, 49, 50, 54, 55, 68, 69, 70, 84, 85, 86, 87, 89, 90, 93, 94, 95 ■

Terry A. Ward is a programmer/analyst for Academic Computing Services, University of Northern Iowa, Cedar Falls, IA 50614.

COMPU SHACK™



**Special
of the
Month!**

IBM PC- COMPLETE LINE

IBM

PC System Includes 64K IBM-PC with 320KB Floppy Disk Drive, Controller, Color Graphics Card, Monochrome Monitor. All for only **\$2599.00**

LOTUS 1-2-3 SOFTWARE .. \$459

TAVA CORP. PRODUCTS



TRUMPCARD

A unique memory card with 256K Ram Game I/O and Serial I/O **\$399.00**

TRUMP CARD II

Serial I/O and 512K fully populated memory card **\$599.00**



AST RESEARCH

IO Plus-Parallel & Serial Port, Clock Calendar W/Bat. back-up, Superdrive, Superspool **\$199.00**

Combo Plus- 256K, Parallel & Serial Port, Clock Calendar W/Bat. back-up, Superdrive, Superspool **\$499.00**

Mega Plus- 512K, Parallel & Serial Port, Clock Calendar W/Bat. back-up **\$999.00**

QUADRAM

Quad Board - 256K, Parallel Port, Serial I/O. Clock Calendar with battery backup **\$599.00**

512K Ram with Serial I/O **\$799.00**

HERCULES GRAPHICS CARD

This card gives you 720 x 350 graphics **\$499.00**

BIG BLUE **\$479.00**

MAYNARD SANDSTAR SERIES

Multifunction Card **..... \$95.00**

Floppy Disk Controller **..... \$225.00**

Memory Card **..... \$189.00**

Add-On Memory Module **..... \$99.00**

Parallel Port Module **..... \$75.00**

Serial Port Module **..... \$95.00**

Clock Calendar Module **..... \$75.00**

Games Adapter Module **..... \$59.00**

OTHER PRODUCTS FOR IBM

THE ULTIMATE SOLUTION TO THE PC EXPANSION DILEMMA FROM LNW COMPUTERS FOR YOUR IBMPC AND PCXT BUSBOARD "MOTHERBOARD".

Allows for addition of eleven (11) different modules and additional processing power through coprocessor BUS **..... \$349.95**

LNW80 CP/M PLUS®

COPROCESSOR MODULE. Z80A module runs CP/M® and CP/M PLUS® as well as CP/M 2.2 programs. For use in both 5" and 8" disk drives **..... \$249.95**

ASYNCHRONOUS COMMUNICATIONS I/O. Allows each Busboard to contain up to 8 separate serial asynchronous channels with a total of 15 different channels **..... \$79.95**

5" OR 8" FLOPPY DISK I/O

MODULE. Replaces disk controller in PC and is compatible with diskettes from other CP/M 86® and CP/M® systems **..... \$169.95**

PARALLEL PRINTER I/O

MODULE. Multi-user Printer port addressing, or general purpose 8-bit I/O port **..... \$49.95**

CLOCK CALENDAR I/O MODULE.

Operates both CP/M 86® and MSDOS®. Also includes back-up battery and Alarm function **..... \$69.95**

GAME I/O MODULE. Compatible with IBM PC Game I/O card. Allows for connection of either 2 joysticks, or 4 paddles **..... \$49.95**

DIRECT-CONNECT MODEM

I/O MODULE. Features answer/dial in tone or pulse for low cost long distance services. Program listing allows for smart modem under BASIC. Speed dialer program included **..... \$149.95**

A/D I/O MODULE. 16 independent multiplexed analog input channels w/8 bits of resolution per channel **..... \$109.95**

8 BIT I/O MODULE. Both latched 8 bits output and input with interrupt capability fully supported. User programmable port addressing for up to 8 modules per Busboard **..... \$59.95**

PROTOTYPING I/O MODULE.

Utilizes 3M Scotchflex Breadboard prototyping system. Complete with 40 conductor I/O BUS connector and an assortment of prototyping pins **\$29.95**

WORD PLUS—PC

Word Processing Software **\$299**

HARD DISK SYSTEMS FOR IBM AND APPLE

DAVONG FOR IBM

	Internal	External
5MB	\$1495	\$1695
10MB	\$1795	\$1995
15MB	\$2295	\$2495
21MB	\$2595	\$2795
32MB	\$2995	\$3195

FLOPPY DISK DRIVES

SHUGART

SA400 SS/SD	\$169.00
SA450 DS/DD	\$239.00
SA800/801 SS/SD	\$365.00
SA850/851 DS/DD	\$459.00



TANDON

TM-100-1 SS/DD	CALL
TM-100-2 DS/DD	CALL
TM-100-4 DS/DD	\$359.00
TM-848-1 SS/DD	\$425.00
TM-848-2 DS/DD	\$499.00

SIEMENS

FDD 100-5	\$159.00
FDD 200-5	\$199.00

DISK DRIVES

For IBM PC	
Tandon 100-2	CALL
Teac 55-B Slimline 320KB	\$260
Shugart SA-455 Slimline 320KB	\$250

THE BUSINESS MANAGER

Integrated Accounting System

The best and most complete business program package on the market. Providing all the software and storage you ever wanted. All software pre-installed on 10 or 15MB hard disk and ready to run. No more diskettes and tedious paper work. High speed. All programs self-prompting and menu driven. Fully guaranteed and supported. **Includes: General Ledger Accounts Receivable Accounts Payable Billing Inventory Payroll Word Processor Spelling Checker File Management Spreadsheet Database Management System** **..... CALL**

*IBM is a registered trademark of IBM Corporation.

*APPLE is a registered trademark of Apple Computers, Inc.

*DATA DRIVE, APPLETTTE 1, APPLETTTE 2, and TRUMP CARD are registered trademarks of TAVA Corporation

**WE'VE MOVED
TO BIGGER FACILITIES
TO SERVE YOU BETTER
PLEASE NOTE OUR NEW PHONE**

(714) 261-1000

Sales and Service: Business & Home Computers

PRICES AND AVAILABILITY SUBJECT TO CHANGE WITHOUT NOTICE

PRINTERS

TAVA PRINTERS BY DIABLO



DOT MATRIX PRINTERS

Model 11

80 Column/100 CPS \$599.00

Model 31

132 Column/100 CPS CALL

Model 32

132 Column/150 CPS CALL

Model 38

132 Column/400 CPS \$1999.00

Tava 80DM

Dot Mtx, Epson MX80

Compatible Printer \$299.00

DAISY WHEEL PRINTERS

Model 620

132 Column/20CPS \$899.00

Model 630

API/40 CPS Letter Quality \$1499.00

Model 630

ECS/API-40CPS

Multi-Lingual \$1899.00

NEC SPINWRITER



NEC

7710-1 \$1995 3510 \$1395

7715-1 \$2195 3515 \$1395

7730-1 \$1995 3530 \$1595

7720-1 \$2595 3550 \$1895

7725-1 \$2595 PC8023A \$ 495

STAR MICRONICS

Gemini 10 CALL

Gemini 15 CALL

SMITH CORONA

TP-1 parallel \$579.00

TP-1 serial \$579.00

C-ITOH

GX-100 (50 CPS Dot Matrix) \$249.00

8510 \$469.00

1550 (15") \$699.00

F-10 (40 CPS, Letter Qual.) \$1395.00

F-10 (55 CPS, Letter Qual.) \$1695.00

OKIDATA

82A \$429.00

83A \$699.00

84AP parallel \$999.00

84AS serial \$1099.00

92A \$525.00

93A \$999.00

IDS PRISM

Prism 132 (B & W) \$1395.00

Color \$ CALL

BROTHER



HR-1 A parallel \$769.00

HR-1 A serial \$869.00

HR-15 \$599.00

Tractor feed option \$135.00

MONITORS

AVAILABLE (All Models) CALL

AMDEK MONITORS

Color I \$359.00

Color II \$699.00

Color III \$399.00

300A \$199.00

310A \$239.00

PRINCETON GRAPHIC SYSTEMS

His Res. Color CALL



APPLE IIe

Computer System, Controller, Two Disk

Drives, Monitor \$1890

TAVA PLUS COMPUTER SYSTEM (APPLE II+ COMPATIBLE)

64K CPU Expandable to 128K 2 Disk

Drives Controller Card Monitor, Parallel

Port, Serial Port, 2 Game I/O's, CP/M® on

board, DOS 3 5 \$1299

Apple II+ Compatible Computer

System W/48K of memory, One "Data

Drive" disk drive, Controller card, 12"

green screen Hi-Resolution Monitor. All

Cables are included for a CompuShack

price of \$999.00

Additional Drive

With purchase of above

System \$100.00

OTHER PRODUCTS FOR APPLE

Special of the Month!

\$259



**TAVA CORP.
DATA DRIVE**

100% Compatible Disk drive for

APPLE II+ and APPLE IIe. Runs DOS.

CPM® Pascal software.

APPLETTE DRIVE \$269

TAVA PRODUCTS FOR APPLE

Cooling System and
Power Monitor \$59

Joystick \$49

80 Column Card \$149

HAYES MICROCOMPUTER PRODUCTS

Micromodem II 300 baud \$299.95

Smartmodem 1200 baud \$529.95

PERSONAL ACCOUNTANT

Software for your Apple IIe and Apple II+

..... \$199.00

EPD PRODUCTS

Lemon Surge Protector \$49.95

Lime Surge Protector \$79.95

Peach Surge Protector \$89.95

Orange Surge Protector \$129.95

Plum Surge Protector \$48.95

DEC Rainbow 100

Keyboard, CPU, Z-80/8088, 64K, Serial

RS232 Port, Two X-400KB Disk Drives,

Monitor, CP/M86®/80 Software, CALL

COMMSOFT PHOTOCASTER

Features a packed system to take, process,

store, print, send and receive color and

black and white photos with your Apple

II computer.

PC 100 Disk software, I/O board, manual,

demo tape \$499.95

PC 101 All the above plus Panasonic TV

Camera, RGB filter accessory \$749.95

CALL YOUR LOCAL COMPUShACK DEALERS:

COMPUShACK

California	Concord	(415) 828-4752
	Irvine	(714) 261-1000
	La Mirada	(213) 947-9505
	San Fernando Valley	(213) 906-7000
	San Jose	(408) 973-1444
	San Ramon	(415) 838-2233
Colorado	Tustin	(714) 730-7227
	Walnut Creek	(415) 945-8011
	Denver	(303) 422-4545
Idaho	Twin Falls	*
Illinois	Chicago	(312) 964-4612
	Great Falls	*
Montana	Missoula	(406) 721-1811
	New York	(800) 228-5525
	Rochester	(716) 924-2544
Texas	Rome	(315) 336-0266
	Austin	(512) 258-1062
Washington	Richland	*
	Spokane	*
Wisconsin	Verona	(608) 845-7110
Canada	Toronto	(416) 249-8601
U.K.	London	01-935-0480

*CALL FOR NUMBER

ALL FLOPPIES REPAIRED QUICKLY AT LOW COST

CP/M and CP/M86 are registered trademarks of Digital Research, Inc.

16861 ARMSTRONG, IRVINE, CA 92714
HEADQUARTERS/TELEX: 181667-ANSWER BACK: COMPUShACK IRIN

Chisel Your Code with a Profiler

This software tool can help you speed up compiled programs

by Dennis Leas and Paul Wintz

The time and effort required to construct a software program for a microcomputer application depend on the tools available. Without software tools it may not be feasible; with an assembler it may take months; with a compiler an application program can be written in only weeks.

A compiler is a tool that reduces the amount of toil required to design, code, debug, and document a program by about a factor of 10. Unfortunately, this 10 to 1 advantage is offset by at least a 2 to 1 size disadvantage. That is, a compiled program's object code is typically at least two times longer than it would be if the program had originally been written in assembly language by a competent programmer.

The amount of code generated is not usually a problem. Each additional 2000 bytes of code above a system's limit require another

EPROM (erasable programmable read-only memory) or ROM chip. Unless you plan to set up 1000 or more identical systems running the program, the extra ROM per system is preferable to the time and expense it would take to write the program in assembly language.

On the other hand, some applications are significantly hampered by

A profiler isolates a section of the code so that you can optimize it for fastest execution time.

the time required by the processor to execute compiled code. If the compiler produces twice as much code, the processor will take twice as long to execute the code. If the additional execution time cannot be tolerated, you must either rewrite the program in assembly language or find some way to make the compiler-generated code execute faster.

Enter the Profiler

A profiler is a computer program that allows you to modify the com-

iled program in order to reduce the execution time to nearly what it would be if the program had been written in assembly language, but at only a fraction of the effort and cost.

Why It Works

If you analyze a microprocessor system that is executing compiled code, you almost always find that the processor spends 90 percent of its time executing 10 percent of the code. In other words, the processor spends most of its time executing a particular subroutine or a small section of the code. The idea is to locate this particular section and then modify it to execute faster. Clearly, finding this section and rewriting it in assembly language is preferable to rewriting the entire program in assembly language.

A profiler isolates a section of the code so that you can optimize it for faster execution time. If the execution speed of this section of the code can be increased by a factor of 2, the execution speed of the total program will be increased by nearly the same factor. The final product is a compiled program that remains twice as large as the equivalent assembly code

Editor's Note: *The profiler program discussed here, written in a combination of C and assembly language, was developed on a Wintek Sprint 68 microcomputer, a 6800-based software development system. However, this programming technique is sufficiently flexible for you to implement it on most microcomputers. . . S. J. W.*

When it comes to superior performance, we study our lines very carefully.

Superior printer performance is not a fluke. It evolves from analyzing printed line after printed line. Taking the time to test and retest. After 30 years of manufacturing precision parts, we know that there are no shortcuts.

And so we took the Gemini-10X and methodically put it through its 120 cps pace. We achieved a print head life of over 100 million characters with an extremely precise dot alignment creating each crisp character.

So far so good.

Next, sophisticated performance demanded versatility. A wide choice of character sets, a buffer expandable to 8K, and the ability to interface with all popular personal computers. We added macro

instruction, giving Gemini-10X the capability to perform up to 16 operations with one command. We included as standard a paper feed system that has a friction and fully adjustable tractor feed. Then we even built in the dexterity to print graphics and text on the same line.

Done.

And, of course, staying the best means constant reviewing and fine-tuning. Keeping the Gemini easy to find, easy to afford and so reliable it can be warranted for up to twice as long as its major competitors.

Only the most careful engineering has built the new hard-working Gemini-10X. You'll applaud its performance.

stairTM
MICRONICS·INC

THE POWER BEHIND THE PRINTED WORD.

Computer Peripherals Division
2803 N.W. 12th Street, Dallas/Ft. Worth Airport, TX 75261



but executes at about the same speed as if it had been written entirely in assembly language.

The profiler monitors an application program while it executes and then computes and displays a histogram of the length of time the application program spends executing different subsections of its code.

Our version of a profiler is an interactive program that first asks you to specify the section of code to be profiled by stating a start address and

a stop address. The section of code to be analyzed could, of course, be the entire program. The profiler then divides this section of code into 16 subsections called "bins." As the application program executes, the microprocessor interrupts every 1/6 second and the profiler examines the program counter. If the value in the program counter (the instruction address) falls within the section to be profiled, the profiler scores a hit and records which of the 16 bins contains the hit. This process continues until

the program finishes or one of the bins fills with a maximum of 255 hits. At this point you can elect to display a histogram of the bin hits in a bar graph on a standard video-display terminal or line printer.

Details of the Profiler

Our profiler's parameters were chosen mainly to facilitate writing the profiler program. The number of bins—16—is convenient for arithmetic operations and as a number of bars to display in horizontal bar graph format on a conventional video display terminal. Six interrupts per second appear to be sufficient and posed no design problems for our profiler because 8-inch floppy-disk drives spin the disk at a rate of 6 revolutions per second and generate an index pulse once per revolution. (On the Wintek Sprint 68 microcomputer the only additional hardware required for the profiler is a jumper on the floppy controller module to feed the index signal to an unused PIA control line to generate the interrupts.)

Our profiler consists of an interactive part and a kernel. The interactive part handles the user interface. It prompts you to enter the FWA (first-word address) and the LWA (last-word address) of the section of code to be analyzed. It then divides this range (LWA to FWA) into 16 equal bins and displays the bin size on the video screen. If the range is not a multiple of 16, it increases the LWA until it is, and so informs you. The interactive part of our version of the program was written in the C language and compiled into 6800 object code on a Wintek Sprint 68 microcomputer.

The kernel part of the profiler is an interrupt-handler subroutine. As a program executes in the normal way an interrupt occurs every 1/6 second. The kernel subroutine reads the value of the program counter from the stack and determines if it falls within the profile range. If so, it scores a hit, increments the appropriate bin counter, and ends with a return from interrupt. When a bin is full (255 hits) interrupts are disabled and the program executes to completion. Our version of the kernel

*** * WE ARE BYTE MAGAZINE'S THIRD OLDEST ADVERTISER * ***

COMPLETE SYSTEMS FOR A WIDE RANGE OF APPLICATIONS, FOR VARIED LEVELS OF SOPHISTICATION. 8 & 16 BIT, S-100 AND NON S-100, SINGLE AND/OR MULTI USER, FLOPPY AND HARD DISK CAPABILITY, SOFTWARE, PERIPHERALS, SERVICE AND SUPPORT.

COMPUPRO/GODBOUT SPOKEN HERE: We are proud of our recent designation as CompuPro Systems Center! We feature the high performance, versatile 8085/8088 dual processor 816 systems with unique version of MP/M that allows simultaneous use of both processors.

NEC APC: The best 8086 system on the market! Gives you more for your money! For under \$4,000: 8086 processor, two double sided, double density 8" drives, 128K RAM, elegant keyboard and monochrome display (color optional), MS DOS and/or CP/M 86.

EPSON QX 10: Truly user friendly. Our entire staff loves this system. You can draw pie charts and bar graphs in two minutes with no prior computer experience! Incredibly easy and satisfying to work with. For under \$3,000: 256K RAM, complete VALDOCS software, HASCI keyboard. We also stock HX20, new FX80 printer.

MASTER MAX: Z80, S-100 with dual 8" drives (Winchester option). Uses Intercontinental Micro CPZ48000 single card computer. 4 DMA channels & universal interrupt controller give great versatility and speed. \$2740 includes CP/M. OPTIONS: double sided drives, TURBODOS, ICMS slave cards, 220v/50HZ operation.

IMS MULTI USER SYSTEMS WITH TURBODOS: Z80, S-100 CP/M compatible. Slave cards give each user Z80 CPU. 64K RAM, 2 I/O. No speed degradation as users are added! Nationwide service depots.

GRAPHICS: MICROANGELO (S-100) OR MIRAGE (RS232). Monochrome or color. AUTOCAD: Interactive graphics software for architects, engineers, others. HOUSTON INSTRUMENTS digitizer and plotters.

ESQ 1: Legal time and billing software implemented on our MASTERMAX, IMS or GODBOUT. On site training and complete software for NY quad state area.

PERIPHERALS: CRTS (Televideo, WYSE, Hazeltine); dot matrix and letter quality printers, S-100 boards & mainframes, floppy disk subsystems (Shugart, Qume, Tandon, Per Sci). Full line of RAM and accessories for IBM PC.

SINGLE OR DUAL WINCHESTER SUBSYSTEMS: Dual version solves back up problems! Implemented for CP/M, Turbodos, TRS 80, IBM PC, Osborne, Apple, many others. Very low prices.

CROMEMCO DUAL PROCESSOR: Z80/68000. Also Z80 C10 p. c.

MODEMS: US ROBOTICS DC Hayes compatible modems at lower prices.

HAZELTINE ESPRIT III: \$795. Televideo 950 emulator, comparable performance for \$200 less! Quantity, OEM and dealer discounts.

3270 NETWORK: Teletype controllers, printers and terminals. Cost effective.

CALL OR WRITE FOR FREE PRODUCT SPECS ON ANY ITEM WE CARRY

WE EXPORT Overseas Callers: Phone (212) 448-6298
TWX 710 588 2844 or Cable: OWENSASSOC

JOHN D. OWENS Associates, Inc.
12 Schubert Street, Staten Island, New York 10305
(212) 448-6283 (212) 448-2913 (212) 448-6298

ANNOUNCING NEPTUNE™

EXTENDED 80-COLUMN CARD FOR APPLE™ IIe

... 64K to 192K memory ... 80-Column display ...

... Upgradable ... FULLY SOFTWARE SUPPORTED ...

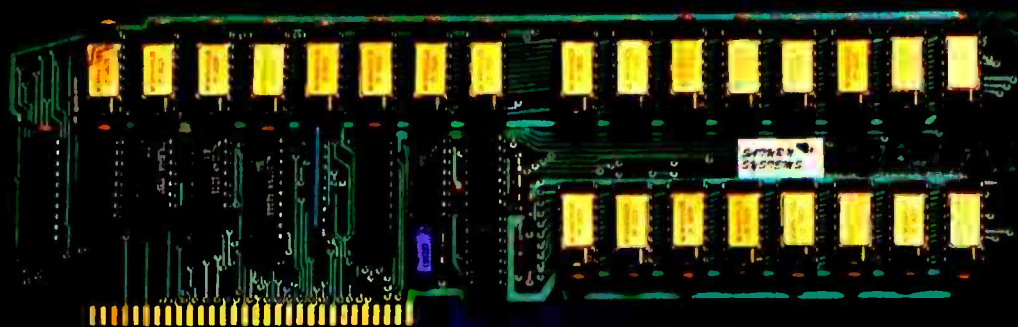

The Neptune Extended 80-Column Card: A plug-in card for the auxiliary slot of the Apple IIe. Available with 64K, 128K, or 192K of RAM memory. Software included for use with VisiCalc™, PASCAL™, GP/M™, and DOS. Card can be used as a fast RAM disk. VC-EXPAND™ program provides up to 220K VisiCalc workspace memory and many other enhancements. Suggested retail price: \$249 with 64K, \$399 with 128K, \$489 with 192K.

Titan
TECHNOLOGIES, INC.
SATURN
SYSTEMS
A Division

P.O. Box 8050
Ann Arbor, Michigan 48107
Telephone (313) 973-8422

For Europe, contact
Pete & Pam Computers
New Hall Hey Road
Rossendale Lancashire
UK BB4 6JG
Telephone (0706) 227611
Telex 635740 PETPAM G

is a 20-line 6800 assembly-language program.

At this point you can direct the interactive part to display a histogram on the video screen or line printer. The histogram is displayed as a horizontal bar graph with the length of each of the 16 bars proportional to the number of hits in the corresponding bin. The profiler scales the bars so that the longest bar is equal to 80 (the number of characters per line on typical video-display terminals).

A Case History

Wintek started the development of a resident 6800 C compiler in 1979 by writing it in C, using the C compiler to compile itself, and writing a 6800 code generator. When first brought up on Wintek's Sprint 68 microcomputer, the C compiler ran too slowly; a test program required 10 minutes and 45 seconds to compile.

We ran the profiler on the compiler as it compiled the test program and obtained the histogram presented in listing 1. Note that the processor spent about half of the 10 minutes and 45 seconds executing the code in the range of 7898 to 8098 (hexadecimal memory addresses). We decided to take a closer look at this section by running the profile over the range 7898 to 8098. This higher-resolution view, shown in listing 2, shows that the code between 7C18 and 7D18 offered the best prospect for improvement. Consequently, we carefully rewrote these routines in assembly language to obtain a modified C compiler. Next, the modified C compiler was used to compile the test program. The performance of the improved C compiler is presented in listing 3. When comparing listings 1 and 3, keep in mind that our profiler scales the histogram so that the largest bin count is 80. The results show that we removed the bottleneck and reduced the execution time from 10 minutes and 45 seconds to 6 minutes and 35 seconds.

Summary

The use of a profiler can greatly speed the development of compiled programs. Because 90 percent of program execution time is required by 10

Listing 1: Output of our profiler from the examination of the C compiler as it compiled a test program. The histogram shows the relative number of times that the processor was interrupted while executing code within each of the 16 different memory locations or bins. The listing shows that code within the memory area of 7898 hexadecimal took the most processing time to execute.

```
01 SY0:PROFILE HISTOGRAM
645 hits recorded
4898 *
5098 *
5898 ***
6098 *****
6898 ****
7098 *****
7898 *****
8098 *****
8898 ****
9098 ****
9898 *
A098 **
A898 *****
B098 *
B898 *****
C098 ****
```

Listing 2: Modified examination of the C compiler as it compiled the test program. By redefining the area of memory recorded by the profiler, we gained a more detailed histogram showing that the code within memory area 7C18 through 7C98 hexadecimal took most of the processing time.

```
01 SY0:PROFILE HISTOGRAM
519 hits recorded
7898 *
7918 *
7978 *
7A18 ****
7A98 *
7B18 *
7B98 *
7C18 *****
7C98 *****
7D18 **
7D98 *
7E18 *
7E98 *
7F18 *
7F98 *
8018 ****
```

Listing 3: Histogram for the revised C compiler. With the processing bottleneck removed, the listing shows a relatively even amount of time required for all sections of the compiler code. The execution time improved from 10 minutes 45 seconds for the original version to 6 minutes 35 seconds for the revised version.

```
01 SY0:PROFILE HISTOGRAM
1001 hits recorded
4898 *
4C98 *
5098 *
5498 **
5898 ..****
5C98 ****
6098 *
6498 *****
6898 *****
6C98 **
7098 *****
7498 *****
7898 *****
7C98 *****
8098 *****
8498 *****
```

percent of the code, modifying the slow 10 percent of the code will be a more efficient use of your time than writing the entire program in assembly language. By developing your own profiler program you can significantly reduce the toil and time required for program development. ■

Dennis Leas is a software engineer for Wintek Corporation (1801 South St., Lafayette, IN 47904). He holds a degree in electrical engineering from Purdue University.

At the time the article was written, Paul Wintz was president of Wintek Corporation. He has since retired from the company and is living in New Zealand.

BUY FACTORY DIRECT

CUSTOM COMPUTER SYSTEMS



MEDICAL



BUSINESS



ACCOUNTING



PROPERTY MANAGEMENT

Answers to some commonly asked

- A:** The Company has been producing computers for 7 years now. We represent and manufacture many different lines of computers, peripherals and supplies.
- A:** The XDS series from U.S. Micro Sales comes to you factory direct; thus cutting out the "middleman" distributor or dealer. You get a tremendous cost savings!! The XDS series is fully expandable including 5 1/4" and 8" floppies, cartridge disks, hard disks, tape backup, etc. We carry a complete line of single user systems, upgradable to multi-user, with the fastest operating speeds in the industry compared to such machines as Apple, IBM, Televideo, etc.
- A:** U.S. Micro Sales XDS series allows you to use any standard CRT terminal, printer, modem, plotter, keyboard, etc. You are not stuck with peripherals which may not fit your needs, or poorly designed, or hard to operate. (i.e. IBM's keyboard, Apple's expandability)
- A:** Our systems use the CP/M operating system which has the largest installed base of application software in the world. CP/M, versus some of the "fad" operating systems is tried and proven and has applications which have been on the market for years.
- A:** U.S. Micro Sales carries a complete line of peripherals — 23 different CRT terminals, 18 printers, 6 lines of modems, etc. We also supply cables for whatever peripherals you order with your system.
- A:** We provide highly documented manuals with each system. Also, the largest collection of free software utilities to work with your system, and a Customer Service "Hotline" to answer your questions and assist you with any field problems. We also offer extended warranties over our 1 year standard warranty!

Questions

- Q:** How long have you been in the industry?
- Q:** Why should I buy an XDS system?
- Q:** Why not buy an IBM or Apple instead?
- Q:** What software runs on your systems?
- Q:** Where do I get peripherals when I buy your system?
- Q:** Who helps me solve problems in the field?
- Q:** What free software will I get with my system?
- Q:** What will "M" Disk do for me?
- Q:** What disk formats is my system compatible with?
- Q:** How can I expand or upgrade my system?
- Q:** What is the difference between your cartridge disk and a conventional hard disk?

Our Toll Free Analysts are ready to answer these and any other questions you may have regarding your data processing needs.

WEST 1-800-854-8174 **EAST** 1-800-435-9357

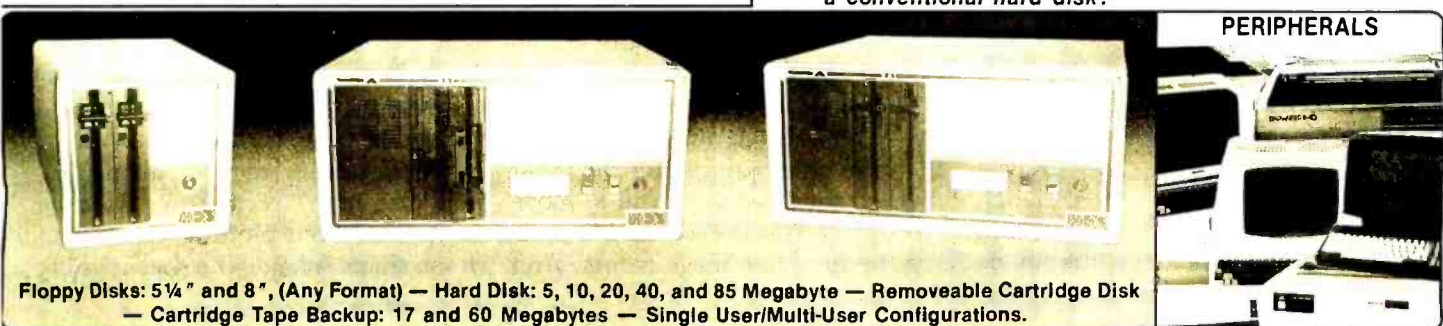

PERIPHERALS

Floppy Disks: 5 1/4" and 8", (Any Format) — Hard Disk: 5, 10, 20, 40, and 85 Megabyte — Removeable Cartridge Disk — Cartridge Tape Backup: 17 and 60 Megabytes — Single User/Multi-User Configurations.

A New Shape Subroutine for the Apple

by Richard T. Simoni Jr.

Athletes pole-vault, race cars spin, and fighter planes fire at enemy aircraft. Is this the real world? No, I'm talking about fast, smooth animation on the Apple II high-resolution graphics screen. In the past year, dozens of new Apple II programs have achieved such awesome animation capabilities that several years ago most Apple programmers would scarcely have believed them possible. After trying unsuccessfully to match the quality of the commercially produced animation in my own assembly-language programs, I realized that the problem stemmed from the standard Apple shape subroutine that I was using to display the shapes I wanted to animate.

Standard Hi-Res Package

The hi-res (high-resolution) graphics package I was using is the standard package supplied by Apple Computer. It once was supplied with all Apple II computers sold, and it can now be found on the volume 3 disk of the Apple Software Bank Contributed Programs, available from Apple dealers. Indeed, this package was eventually incorporated into the Applesoft language to add hi-res commands. Written in machine language, the package includes subroutines to clear the screen, plot a point, draw a line, and draw a shape on the hi-res screen. Although the clear, plot, and line subroutines work well in animation, the shape

subroutine is much too slow to allow shapes to move across the screen quickly, smoothly, and without flickering.

The speed of the shape subroutine is the most important factor in animation for two main reasons. First, the speed with which the subroutine can plot the shape, erase it, and plot it again in its next position limits how fast any shape can move across the screen. Second, in a typical animation scheme, a shape moves from one position to the next in four phases, which correspond to the time required to plot the shape, the time the shape remains on the screen, the time required to erase the shape, and the time that the shape is not on the screen at all. These four phases repeat each time a shape moves to a new position. The time spent during each phase of the process determines how fast the shape moves and how smooth and flicker-free the animation looks. To maximize the smoothness, the time used in plotting the shape, erasing the shape, and leaving the shape off the screen must be minimized, for the human eye perceives these phases as contributing to the flicker of the image. On the other hand, if the amount of time the eye sees the image whole on the screen is significantly greater than the time required for the other phases, the image appears to move smoothly across the screen. Minimizing the time the image is totally off

the screen is not difficult, for all calculations for the next plot can be done while the image is on the screen; when the image is erased, it can then be immediately plotted in the new position. The times required to plot and erase the shape, however, are directly determined by the speed of the image subroutine. If the subroutine is slow, the plot and erase times are long, and the image appears to flicker as it moves across the screen.

Representing Shapes

To understand why the standard Apple shape subroutine is too slow for most animation purposes, you must know how the subroutine works and especially how it expects a shape to be represented in memory. A shape is represented by a series of vectors in memory, with each vector specifying if a given pixel should be turned on. It also specifies which of the four adjacent pixels should be addressed by the next vector. This scheme best suits the representation of simple, single-line shapes such as those in figure 1. Unfortunately, if a shape must be filled in or if the shape has any detail drawn within its boundaries, as in figure 2, the shape's representation is awkward and inefficient at best. In these cases it is often necessary to overplot points and use many vectors that specify motion without plotting. Moreover, if the shape is large, the sheer size of

(1a)

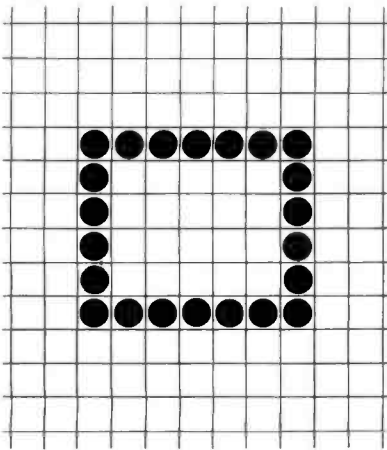

(1b)

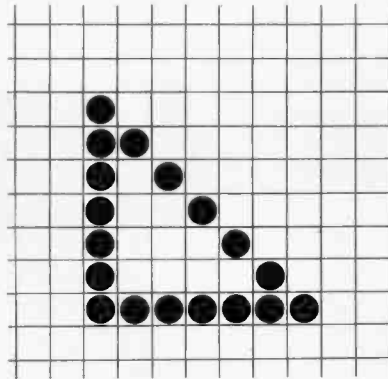

(1c)

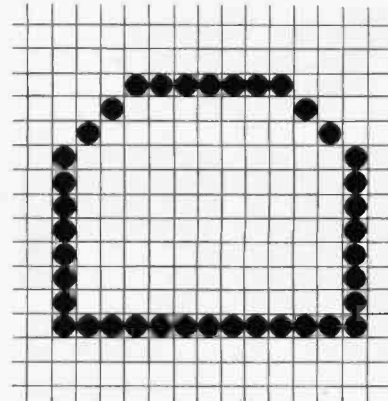

Figure 1: Because they are easily represented in memory by a series of vectors, these simple single-line closed shapes are suitable for display by the standard Apple shape subroutine on the hi-res graphics screen.

the vector table becomes unwieldy. When the time comes to plot these shapes, the subroutine steps through the table, and each vector takes up a certain amount of time. If the vector table represents the shape inefficiently, the end result is wasted time in the plotting of the shape.

Similarly contributing to the slow speed of the shape subroutine is the inclusion of scaling and rotation factors. In order to plot a shape, a calling routine must specify a scaling factor that determines the plotted shape's size (actual size, double size, triple size, etc.) and a rotation factor that determines the angle through which the shape is rotated before

plotting. Although these factors are useful in some applications, using them with shape animation rarely produces satisfying results, and these calculations slow the subroutine considerably.

A New Shape Subroutine

After realizing that the speed bottleneck in my programs was caused by the shape subroutine, I went about designing my own subroutine with two criteria in mind. First, the subroutine had to be high speed to minimize image flicker, and second, the method of representing a shape in memory had to allow complicated images to be plotted as quickly as

simple single-line shapes of the same overall size. One way to meet these criteria is to use a bit picture to represent the shape in memory. In other words, the shape is represented in main memory in the same form in which it is ultimately represented in the hi-res screen memory when the shape is plotted on the hi-res screen. Plotting the shape is then simple and fast: the bytes representing the shape in main memory need only be transferred to the hi-res screen memory. I used this technique in writing a fast shape subroutine suitable for animation.

The table of bytes that make up the bit picture is called the shape table.

(2a)

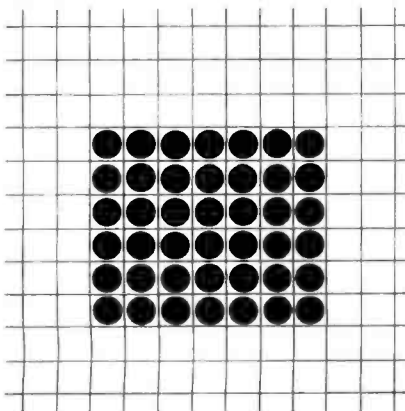

(2b)

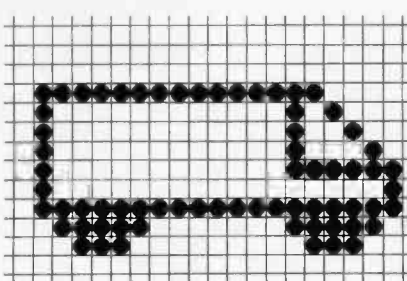

(2c)

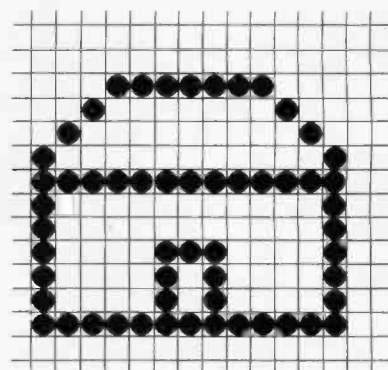

Figure 2: The detail within these shapes makes their representation as vectors in memory inefficient; therefore, the standard Apple shape subroutine is neither well suited nor easy to use for the display of these shapes on the hi-res screen.

We Offer You More!

That's right. If you compare the benefits of ordering from National Computer to all our competitors, you'll see why more smart shoppers buy from us everyday. We save you money even before you order with our toll free 800 line, and then if you find a lower advertised price we'll meet it. Since we stock what we advertise you can rest assured your order will be shipped promptly. In addition, if for any reason you are not satisfied with any merchandise you purchase from National Computer you may return it for exactly what you want or a full refund. Check us out! We've been in business for over 4 years, and one glance at our catalog will demonstrate the commitment we have to direct marketing and to our fine customers.



Video Monitors

AMDEK 300 12" Hi-res green	145**
AMDEK 300A 12" Amber	150**
AMDEK Color II Plus 13" Color	329**
AMDEK Color II Hi-res RGB	649**
COMREX 5600 12" Hi-res amber	179**
NEC 1201M 12" Hi-res green	159**
TAXAN Vision 12" med-res RGB32*	329**
TAXAN Vision 3 12" Hi-res RGB	499**
TAXAN 12" Hi-res amber	149**
ZENITH 12" Hi-res green	110**



MicroPro

WordStar 269**
 Random House Thesaurus 129**
 MailMerge
 SuperSort
 SpellStar
Only \$169.95 ea.
 Call for special package deal pricing.



Kaypro

The anytime-anywhere computer. Includes CP/M, GBIASIC, a spreadsheet and wordprocessing software.

PLEASE CALL FOR MORE DETAILS.

Popular Software

dBASE II/MS-DOS or CP/M 861	429**
LOTUS 1-2-3	Please call for details
PC Tutor by Comprehensive	69**
Home Accountant Plus	115**
T.I.M. III by Innovative	339**
EasyWriter II	239**
Crosstalk by MicroStar	129**
Concurrent CP/M Digital Rsch	Call
Peacetrack GLARAP Series 4 Pak	399**
SuperCalc by Sorcim	199**
SuperWriter by Sorcim	269**
Versaform	269**
VoiksWriter by Lifetime	139**
Microsoft Multi-Plan	179**
Flight Simulator	39**



PRINCETON PGS HX-12
IDEAL FOR IBM PC!

High Resolution 12" RGB Color Monitor.

- 80 character x 25 lines
- 690 dots horizontal resolution
- 16 colors
- Includes IBM PC cable
- Very affordable

PLEASE CALL FOR MORE DETAILS AND PRICE

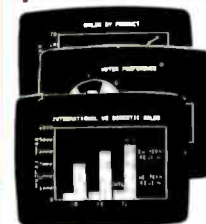

VisiCorp

VisiCalc \$179.95

VisiFile
 VisiTrend/Plot
 VisiSchedule
 VisiWord (req. 128K) 299**

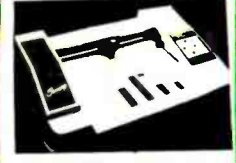

Sweet-P Graphic Plotter

A simple to operate plotter which easily interfaces to the PC using a centronics parallel port. Complete with software, set of pens, paper and operator's manual. List Price \$795.00
 Special Offer 529**



QUADLINK
 by Quadram
Only \$499.95

Diskettes

Buy 100
3M Scotch 5 1/4" SS/IDD
diskettes \$219.95

3M Scotch 5 1/4" SS/IDD Box of 10 25**
 3M Scotch 5 1/4" DS/DD Box of 10 35**
 Verbatim 5 1/4" SS/IDD Box of 10 29**
 Head Cleaning Diskette 5 1/4" 27**

Now you can run Apple software on your IBM PC. Advanced technology from the IBM PC peripheral leader, Quadram, has made it possible. Quadlink allows using all IBM enhancements while running Apple software, including all peripherals. Now you can enjoy the best of both software worlds including hi-res games, special packages not available on the IBM PC. Appize your IBM today!

Your Guarantee of Satisfaction

We guarantee every item in this advertisement for 30 days. If, for any reason whatever, you are not satisfied with any merchandise purchased from us, we want you to return it to us at our expense. We will exchange it for exactly what you want, or will refund your money, and include any shipping charges you have paid.

NATIONAL COMPUTER PRODUCTS

Modems

Hayes Smartmodem 300	219**
Hayes Smartmodem 1200	455**
Novation J-Cat 0-300 baud.	125**
Anchor Mark 1300 baud	94**
Anchor Mark VIII 300*, 1200 baud 399**	
RIXON PC212A (IBM PC)	CALL
CACTUS Technology (IBM PC)	299**

To order please send money order or cashier's check. Personal checks 3 weeks to clear. Prices reflect 2% cash discount. We accept VISA, MasterCard, American Express, Diners Club and Carte Blanche. Shipping, handling & insurance charges, add 3% of merchandise total (min. \$5.00). California residents add 6% sales tax. Foreign customers please call or write. Prices and availability subject to change without notice. All equipment is new and warranted by the manufacturer.



COMMODORE 64

CALL FOR NEW SPECIAL PRICE

COMMODORE 1541 Disk Drive Call
 Dataselle program recorder 65**
 DATA 20-Z80 & 80 column pac 229**
 CARDICO Centronics Interface 79**
 MicroSystem RS-232 interface 59**
 APPLE Emulator 99**

We carry a complete line of accessories and software for the Commodore. Please call.



EPSON FX-80

160 cps 10" carriage, 2K buffer
 Epson FX-80 Tractor 39.95

EPSON FX-100 Please call for our low prices

GEMINI 10X	
GEMINI 15	
C.I.TOH 8510	
C.I.TOH 1550	
NEC 8023A	
FACTIT 4510	



ATARI 1200XL

Only \$549.95

ATARI 800 with 48K 449**
 ATARI 810 Disk Drive 429**

We carry much more for Atari! Call



OKIDATA ML92

160 cps, 10" carriage, 80 columns
Only \$499.95

Delender - Dig Dug
Donkey Kong - Galaxian
Pac Man - Centipede
Qix - Star Raiders
Missile Command - Miner 2049

YOUR CHOICE Only \$39 ea.**

Tractor for ML 92 59**
 OKIDATA 93 869**
 OKIDATA 82A with tractor 459**
 OKIDATA 84A par. w/tractor 999**



corona

IBM PC COMPATIBLE DESKTOP COMPUTER

128K, dual 320K disk drives, 9" display, serial & parallel ports, and MS-DOS.



TRANSTAR 315 Color Printer

Prints 7 colors plus more than 30 shades, all in a single pass of the print head. And it's built by Seiko.

Only \$549.95

IBM PC COMPATIBLE PORTABLE - PORTABLE

128K dual 320K disk drives, 9" display, serial & parallel ports, and MS-DOS.

Please call or write for more details.



Letter Quality Printers

C.I.TOH F-10 Starwriter 40 cps	1149**
C.I.TOH F-10 Starwriter 55 cps	1549**
Daewoo 40 cps w/16K buffer/1049**	459**
NEC 3510 33 cps RS-232 serial	1449**
NEC 3530 33 cps parallel	1589**



HAYES IBM PC MODEM

Smartmodem 1200B

With Communications Software

Only \$449.95



Apple II Accessories

Grappler Plus	129**
PKASO Interface	135**
GRAPPLER Bufferboard 16K	139**
MicroModem II by Hayes	269**
Videx 80 column card	239**
Enhancer II	319**
ULTRATERM 128x48 Video card	339**

Modems

Hayes Smartmodem 300	219**
Hayes Smartmodem 1200	455**
Novation J-Cat 0-300 baud.	125**
Anchor Mark 1300 baud	94**
Anchor Mark VIII 300*, 1200 baud 399**	
RIXON PC212A (IBM PC)	CALL
CACTUS Technology (IBM PC)	299**



NEC 3550 Sprinwriter for IBM PC

Only \$1889.95



Columbia VP Portable

Featuring IBM-PC and COMPAQ compatibility teamed with the most comprehensive software package in the industry to deliver all the functions you need. Includes 128K RAM, expandable to 256K, 2.5" half-high floppy disk drives with 320K DS/DD, 9" green screen, 80x25 characters. Full IBM compatible keyboard. The unit only weighs 32 lbs.

PLEASE CALL FOR MORE DETAILS.



IBM Personal Computer

Includes 64K, 2 DS/DD 320K drives, keyboard, color video card, & MS-DOS

PLEASE CALL FOR SYSTEM PRICES.



Apple Disk Drives

Special buy! Fourth Dimension drive w/controller Only \$299.95

PLEASE CALL FOR MORE DETAILS.

Fourth Dimension 249**
 MicroSci A2 299**
 MicroSci A2 with controller 369**
 Rana Elite I 289**
 Rana Elite I w/controller 339**
 Corona 5 megabyte hard disk 1895**



Columbia MPC

IBM PC compatible system

Includes 128K, 2 DS/DD 320K drives, keyboard, video card, MS-DOS & CP/M 86 software. Monitor not included.

PLEASE CALL FOR SYSTEM PRICES.

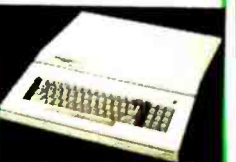

FRANKLIN ACE 1000 & 1200

Apple II compatible computer - 64K, upper/lower case, and more!

PLEASE CALL FOR DETAILS

System packages at special prices.



ACCESSORIES For IBM PC

Quadram Quadboard 64K Only \$269.95

128K 349** 192K 419** 256K 499**
 64K 299** 256K 489** 512K 749**



Apple II Accessories

Grappler Plus	129**
PKASO Interface	135**
GRAPPLER Bufferboard 16K	139**
MicroModem II by Hayes	269**
Videx 80 column card	239**
Enhancer II	319**
ULTRATERM 128x48 Video card	339**

AST MegaPlus

64K with serial & clock	339**	
128K 399**	192K 449**	
256K 499**	64K with parallel & serial	379**
128K 439**	192K 499**	256K 549**
MegaPak Option (256K) for 512K total		329**



MICROSOFT MICROSOFT PREMIUM SYSTEM

Includes: 2-80 SoftCard, 16K RamCard, Video Videoterm, SoftSwitch, & CP/M User Guide by Adam Osborne. List 755.00

Special Price Only \$459.95

ComboPlus

64K with Serial, parallel & clock. 339**
 128K 399** 192K 459** 256K 499**

I/O Plus

Serial, parallel, clock and game adapter port 195**

Apparat, Inc.

ComboCard with parallel printer port, Asynchronous communications / RS-232 port, and clock/calendar 169**
 RS 232 cable for combo card 29**

Monte Carlo Card

64K 449** 128K 529** 256K 649**

Disk Drives For IBM PC

5 megabyte internal drive & ps 1529**
 10 megabyte internal drive & ps 1879**
 For external drive model add \$300**
 Call for prices on Davong and Rana drives.

Tandon IM100 2 DS/DD	249**
Trak DS/DD 500K 40 track drive	269**
Trak 4 drive floppy controller	149**
Trak 5 megabyte 5 1/4" hard disk	799**
PC Mouse	249**
Big Blue 2-80 Card	469**
Nine 4164 200ms Ram Chips	69**

NATIONAL COMPUTER PRODUCTS

8338 Center Drive, La Mesa, CA 92041-3791 AD-B883

Information on products, and order inquiries call (619) 460-6502 Calif., Alaska, & Hawaii Call (619) 698-8088

DEALERS, WE BUY EXCESS STOCK, PLEASE CALL OR WRITE

www.americancomputer.com

2 FOR THE SIZE OF 1

All apples taste different, so is our drive.

Features:

- *Brushless, direct shaft driven.
- *Fast track-to-track time, 3-6 msec.
- *40 tracks. Low cost.
- *One full year warranty.

SEKON 64	\$695
SEKON-5 Drive	\$265
128K RAM-DISK	\$265
80 Column Card	\$115
Z80 Card	\$ 95
RS-232 Card	\$ 95
SEKON64 bare board	\$ 75
Parallel Interface	\$ 80
EPRON Card	\$120
Disk Controller	\$ 65
Language Card	\$ 50
RF with sound	\$ 25
RF modulator	\$ 19
DB25P connector	\$2.25
DB25S connector	\$3.05
57-30360 connector	\$5.75
DSDD Diskette	\$1.95
SSDD Diskette	\$1.90

*All items have a one year warranty.



SEKON COMPUTER introduces another Second-to-none product, the SEKON-5 Disk drive, for Apple IIe, SEKON 64, IBM PC or other computers. Like our interface cards, SEKON-5 costs less and performs better. And it has a one full year warranty. Call your dealer or us for our extra special introductory offer. Dealer enquiries invited.



"SEKON, Second to None!"

SEKON INT'L. CORP. OF AMERICA (800) 423-4303, in CA (213) 936-1577
2210 Wilshire Blvd., Suite 577, Santa Monica, CA 90403 Telex 181121

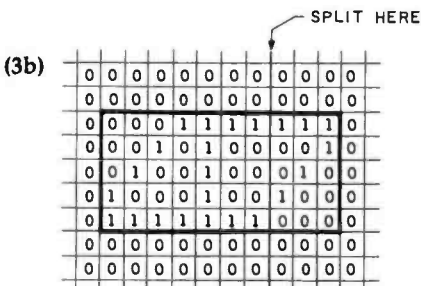
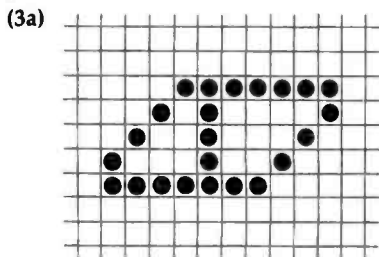

0001111	1110000
0010100	0010000
0100100	0100000
1000100	1000000
1111111	0000000

ADDED ZEROS

(3c)

1111000	0000111
0010100	0000100
0010010	0000010
0010001	0000001
1111111	0000000

(3d)

78	07
14	04
12	02
11	01
7F	00

Figure 3: To form a shape table, start by drawing the desired shape on graph paper, using 1s and 0s to represent "on" and "off" pixels (3a). Next, split each line of bits into 7-bit groups, padding the last group of each line with 0s if necessary (3b). Then, reverse the order of the binary digits in each 7-bit group (3c) and convert to hexadecimal (3d). Later you must add height and width bytes as described in the text.

A shape table is most easily formed through the use of the shape-editor program presented later in this article. To form a shape table manually, start by drawing the shape on a piece of graph paper with one pixel per square, as in figure 3a. Use 1s to represent on pixels and 0s to represent off pixels. Draw the smallest possible rectangle that still encloses

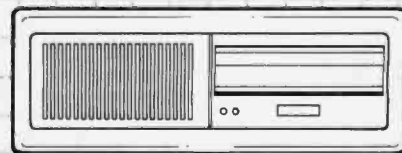
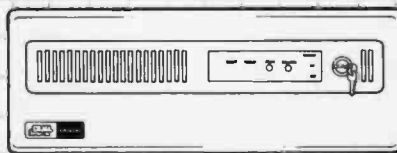

SYSTEM 83

What's your problem?

Software development; color graphics; high speed communications; industrial control & robotics (FORTH); word processing/document formatting; computer time-sharing; timing of Hawaiian marathon; farm management; CAD/CAM, laboratory control; CAT scan, dermatology graphics; medical analysis; pattern recognition (music/speech); relational database; telecommunications; mobile geophysical studies; data copying; automatic typesetting; data processing security ...

What is your need? Let DUAL SYSTEMS be the solution.

IEEE-696/S-100 based, 68000/UNIX™ multi-user/multi-tasking, 20/80M byte.

Call today for information!



UNIX is a trademark of Bell Laboratories

DUAL SYSTEMS CORPORATION

2530 San Pablo Avenue • Berkeley • CA 94702 (415) 549-3854 • 172029 SPX

Do you have the the entire S-100

We do.

And now you can too: The most powerful multi-processing CPU board you can buy. The world's first 256K static RAM memory board. And the most sophisticated hard disk controller board available.

Run 8-bit CP/M 80* and 16-bit CP/M 86* simultaneously in a single or multi-user environment. \$895.

Now you can upgrade to 16-bit without forsaking your investment in 8-bit software. Octagon's plug-and-play CPU Board 8/16™ is a complete computer-on-a-board with all this:

- Dual processors: 4MHz NSC-800 (executes full Z80* instruction set) and 8MHz 8088.
- Intel 8272 floppy disk controller with 24-bit DMA. Runs up to four 5¼" or 8" floppies in any combination at the same time.
- 8K PROM monitor. Boots operating system and also contains all the disk interface software you need for almost any operating system. Plus many useful debugging features, such as memory test, memory dump and memory search.
- Two serial ports (baud rate software selectable up to 19.2 Kbauds.)
- Interrupt controller with eight vectored interrupts.

- Fixed frequency real-time clock interrupt for multi-user dispatching.
- IEEE-696 S-100 compatible.

Add the optional 8087 math co-processor for just \$300.

And save \$155 when you buy the operating system from Octagon, whether you take Concurrent CP/M 86 at \$195, CP/M 86 at \$150 or MP/M 86* at \$495.

CPU Board 8/16 is completely ready to run with no additional software. And both operating systems automatically include your CP/M 80 emulator, so you can run any 8-bit CP/M program—as well as auto-select bios that let you transfer files back and forth between 5¼" and 8" floppies.

World's first 256K Static RAM Memory Board. \$1850

Memory may be configured as either four totally independent 64K software-selectable blocks or as a single 256K block which responds to IEEE-696 extended addressing lines. Will accept either 8-bit or 16-bit bus requests.

And each 64K block can be one of 256 addresses—so theoretically you could address

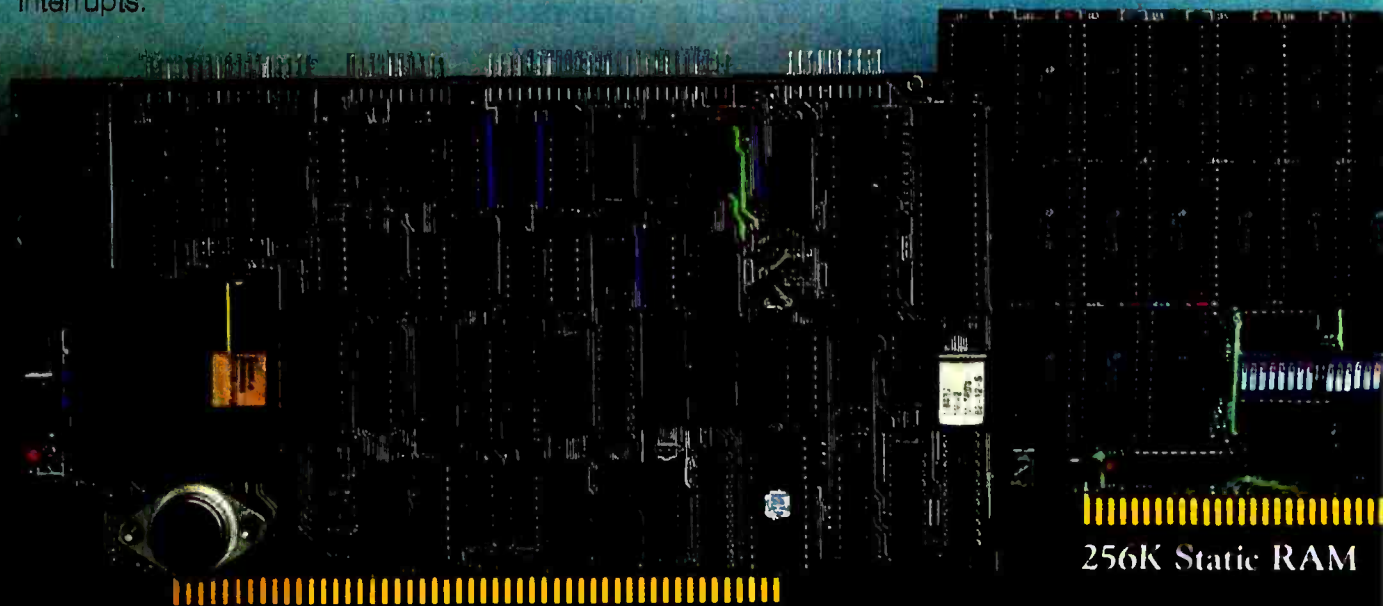

CPU Board 8/16

256K Static RAM

guts to take on micro industry?

up to 16MB of these boards in your system.
A partially populated 128K board with the
same characteristics is just \$1095.

Sophisticated, reliable Hard Disk Controller. \$550.

Designed around LSI technology for greater
reliability. With its sophisticated Western Digital



1010 hard disk controller chip to control up to four
5¼" drives, this unique board gives you automatic
seek, automatic retries after error; comes
with both CP/M 80 and CP/M 86 bios; and
includes two serial ports and one Centronics-
compatible parallel port.

Using the WD 1014, it detects and corrects
single-bit errors and detects double-bit errors.

ECC generation and correction on data fields is
user selectable.

And its phase lock loop lets you forget about
critical timing adjustments. In fact, you never need
to adjust it at all. There's no pot.

Octagon's Hard Disk Controller Board also
gives you data rates up to 5Mbits/sec., and CRC
generation and verification on ID fields. Complete
subsystem including board and 19.2 MB hard
disk packaged with power supply: \$2195.

1-408-262-7777

Call us now for more details. And take advantage
of these introductory offers: Buy CPU Board
8/16 plus the Memory Board and get Concurrent
CP/M 86 or CP/M 86 free. (Includes CP/M 80 em-
ulator.) Or buy all three boards and get MP/M *plus*
new Personal BASIC from Digital Research free.

You'll never need any other S-100 boards. It
takes guts to say that, but try us out and you'll
know: Octagon has what it takes.

Circle 291 on Inquiry card.

 **Octagon**

2960 North First St., San Jose, CA 95134 408-262-7777

*CP/M 80, CP/M 86, MP/M 86 and Personal BASIC are trademarks
of Digital Research. Z80 is a trademark of Zilog.

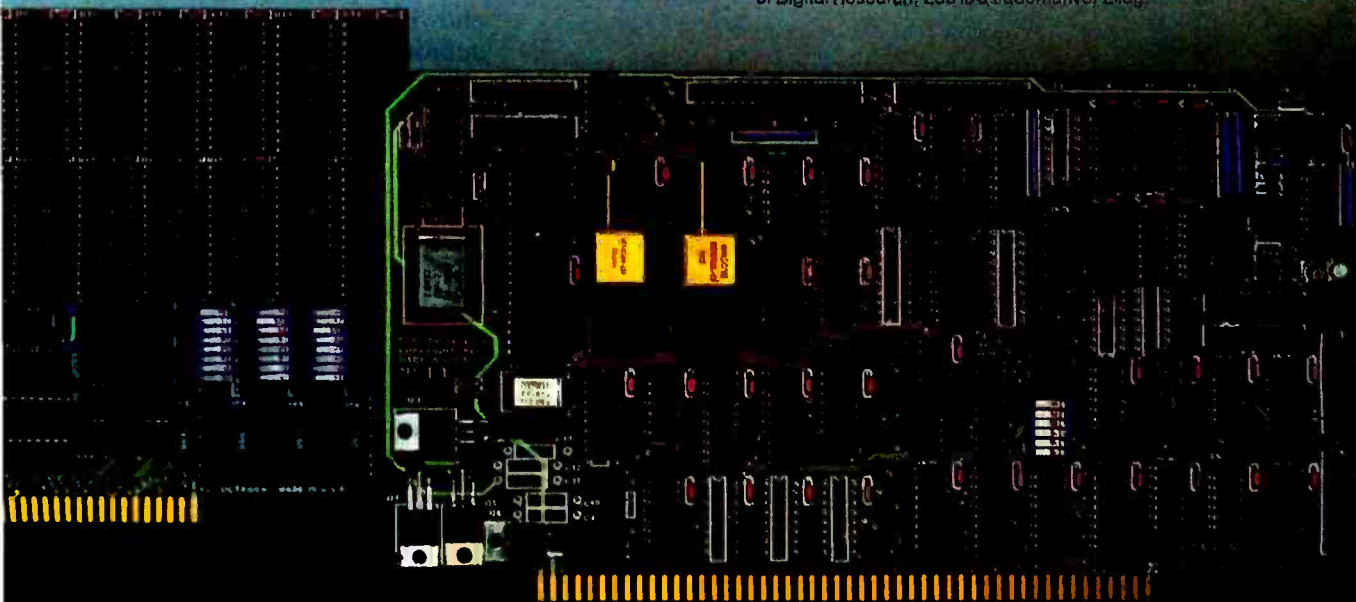

Hard Disk Controller

Listing 1: A fast shape subroutine that plots high-resolution shapes on the Apple II.

```

0000:      1          OBJ $1800
1800:      2          ORG $1800          ;ASSEMBLY LOCATION
1800:      3          *****
1800:      4          * SHAPE SUBROUTINE WRITTEN BY RICHARD T. SIMONI, JR. *
1800:      5          *
1800:      6          * SHAPE WORKS BY STEPPING THROUGH THE USER TABLE ONE *
1800:      7          * HI-RES LINE AT A TIME, SHIFTING THE BIT PATTERN THE *
1800:      8          * APPROPRIATE NUMBER OF TIMES (DEPENDING ON THE *
1800:      9          * X-COORDINATE PASSED IN THE X- AND Y-REGISTERS), AND *
1800:     10          * MOVING THE PATTERN TO THE PROPER PLACE IN THE HI-RES *
1800:     11          * SCREEN MEMORY. *
1800:     12          *****
1800:     13          STARTZ EQU $19          ;START OF LINE STORAGE
1800:     14          YCOORD EQU $E3        ;LINE COUNTER
1800:     15          START EQU $EB        ;USER TABLE POINTER
1800:     16          ADDR1 EQU $ED        ;1ST SCREEN BYTE TO USE
1800:     17          ADDRH EQU $EE        ; IN LINE YCOORD
1800:     18          ADDRADD EQU $EF       ;OFFSET FROM LEFT BYTE
1800:     19          SHFTNUM EQU $F9       ;NUMBER OF SHIFTS
1800:     20          ENDLN EQU $FD        ;LAST LINE + 1
1800:     21          WIDTH EQU $FB       ;WIDTH OF USER TABLE
1800:     22          INDEX EQU $FC       ;POINTER IN USER TABLE
1800:     23          *
1800:     24          * DIVIDE X-COORD BY 7 TO GET BYTE OFFSET FROM LEFTMOST
1800:     25          * BYTE IN ANY HI-RES LINE. REMAINDER WILL BE CORRECT
1800:     26          * NUMBER OF SHIFTS TO PERFORM ON BIT PATTERN.
1800:     27          * DIVISION IS PERFORMED USING LOOKUP TABLE FOR SPEED.
1800:     28          *
1800:     85 E3      29          STA YCOORD          ;STORE Y-COORD (COUNTER)
1802:     8A      30          TXA
1803:     0A      31          ASL A
1804:     AA      32          TAX
1805:     98      33          TYA
1806:     2A      34          ROL A
1807:     A8      35          TAY          ;MULTIPLY X-COORD BY TWO
1808:     18      36          CLC
1809:     8A      37          TXA          ;A-REG = X-COORD*2 LO-BYTE
180A:     69 83   38          ADC #>QUOTBL      ;ADD TABLE ADDRESS LO-BYTE
180C:     85 ED   39          STA ADDR1        ;STORE RESULT
180F:     98      40          TYA          ;A-REG = X-COORD*2 HI-BYTE
180F:     69 1B   41          ADC #<QUOTBL      ;ADD TABLE ADDRESS HI-BYTE
1811:     85 EE   42          STA ADDRH        ;STORE RESULT
1813:     A0 00   43          LDY #00          ;ZERO Y-REG FOR INDEXING
1815:     B1 FD   44          LDA (ADDR1),Y      ;LOAD X-COORD/7 FROM TABLE
1817:     85 EF   45          STA ADDRADD      ;ADDRADD = X-COORD/7
1819:     C8      46          INY          ;REMAINDER FOLLOWS IN TABLE
181A:     B1 ED   47          LDA (ADDR1),Y      ;LOAD REMAINDER FROM TABLE
181C:     95 F9   48          STA SHFTNUM      ;SHFTNUM = REMAINDER
181E:     49          *
181E:     50          * INITIALIZE LOCATIONS ENDLN AND WIDTH. ENDLN CONTAINS
181E:     51          * THE Y-COORD OF THE LAST LINE + 1. WIDTH CONTAINS THE
181E:     52          * WIDTH (IN BYTES) OF EACH LINE.
181E:     53          *
181E:     A5 E3   54          LDA YCOORD
1820:     A0 00   55          LDY #00
1822:     18      56          CLC
1823:     71 EB   57          ADC (START),Y
1825:     85 FD   58          STA ENDLN          ;ENDLN = Y-COORD+LENGTH
1827:     C8      59          INY
1828:     B1 EB   60          LDA (START),Y
182A:     85 FB   61          STA WIDTH          ;GET & STORE WIDTH
182C:     C8      62          INY
182D:     84 FC   63          STY INDEX          ;INDEX=2
182F:     64          *
182F:     65          * LOOP1 IS THE LOOP THAT IS CYCLED THROUGH ONCE FOR EACH
182F:     66          * LINE ON THE HI-RES SCREEN
182F:     67          *
182F:     A6 FB   68          LOOP1 LDX WIDTH          ;X-REG=0 (COUNTER)
1831:     A4 FC   69          LDY INDEX
1833:     70          *
1833:     71          * MOVE BYTES FOR LINE YCOORD FROM USER TABLE TO ZERO PAGE
1833:     72          *
1833:     B1 FB   73          LOOP2 LDA (START),Y      ;GET XTH BYTE OF LINE
1835:     95 19   74          STA STARTZ,X      ;STORE IN STARTZ+X
1837:     C8      75          INY
1838:     CA      76          DEX          ;MOVED ALL BYTES YET?
1839:     D0 F8   77          BNE LOOP2          ;NO, LOOP
183B:     86 19   78          STX STARTZ      ;STARTZ=0
183D:     84 FC   79          STY INDEX
183F:     80          *
183F:     81          * SHIFT THE BIT PATTERN SHFTNUM TIMES
183F:     82          *
183F:     A4 F9   83          LDY SHFTNUM      ;IS SHFTNUM=0?
1841:     F0 16   84          BEQ SKIP          ;YES, SKIP THE SHIFTING
1843:     18      85          LOOP3 CLC          ;NO, START SHIFTING
1844:     A6 FB   86          LDX WIDTH
1846:     08      87          PHP          ;KEEP STACK IN ORDER
1847:     28      88          LOOP4 PLP          ;RESTORE CARRY
1848:     B5 19   89          LDA STARTZ,X      ;LOAD ORIGINAL PATTERN
184A:     2A      90          ROL A

```

the entire figure. Then split each line of binary digits enclosed by the rectangle into 7-bit groups. If, as in figure 3b, the last group doesn't have a full 7 bits, add enough 0s to the end of each line to bring the total up to 7 bits. Due to limitations to the subroutine, no more than seven 7-bit groups per line are allowed. Reverse the order of the bits in each group, as shown in figure 3c. Convert each new 7-bit group into its hexadecimal or decimal equivalent, whichever is preferred (figure 3d shows the hexadecimal equivalent) and, reading across each line left to right from the top to the bottom line, recopy the list of numbers in table (linear) form. The table is now complete except for two bytes that belong at the top of the table. The first of these bytes represents the height of the shape—in other words, the number of lines of digits in figure 3b; the second byte represents the width of the shape in 7-bit groups—that is, the number of 7-bit groups used in each line in figure 3b. As previously mentioned, this width should be no more than seven groups. The complete table in hexadecimal form for the sample shape used in figure 3 is as follows:

```

05 02 78 07 14 04 12 02
11 01 7F 00

```

The shape subroutine itself is shown in listing 1, and the lookup tables used by the subroutine are shown in listing 2. Before calling the subroutine, several registers and memory locations must be set up with certain parameters, including the hi-res screen coordinates of the pixel where the upper left corner of the bit picture should be positioned. The low-order byte of the x-coordinate should be placed in the X register, and the corresponding high-order byte of the x-coordinate (either 1 or 0) goes in the Y register. The y-coordinate goes in the A register (accumulator). The low- and high-order bytes of the shape-table starting address should be stored in hexadecimal memory locations EB and EC, respectively. The subroutine can then be called with the usual JSR instruc-

Listing 1 continued on page 300

Text continued on page 303

ROCKY MTN. MICRO, INC.

HIGH TECHNOLOGY PRODUCTS & SERVICE FROM THE HIGH COUNTRY

IBM-PC HARDWARE

QUADRAM CORPORATION

QUADCHROME RGB Color Monitor
THE High Resolution Monitor for your IBM-PC.
100% IBM Compatible. Includes cable. 690 by
480 Resolutions: 16 colors \$ CALL

QUADBOARD Multifunction Board
Full expandability from 64K to 256K
Parallel Printer Port
Asynchronous RS232 Serial Modem Port
Programmable Clock/Calendar
RAM Disk Drive (software)
64K starts at \$ 299.00

MICROFAZER Printer Spooler

Print Buffering from 8K to 512K
Any Printer/Computer Combination
Why wait on your printer?
Prices (w/power supply) start at \$ 139.00

QUADLINK RUN APPLE SOFTWARE ON YOUR

IBM/SWITCH BACK & FORTH BETWEEN
APPLE & IBM PROGRAMS AT WILL. USE
YOUR IBM DRIVES. WRITE TO DISC
DOS33 \$ CALL

QUADCOLOR I IBM color card \$ CALL

QUADCOLOR II 640 by 200 \$ CALL

QUADCOLOR III 640 by 400 \$ CALL

TANDON TM 100-2 320K Drive \$242.00
TANDON "SLIM-LINE" TM50-2 \$ CALL

STB SYSTEMS "SUPER RIO" CARD

The Truly ultimate IBM add-on Eight + Functions
on one card.

- 64-256K (786K w/opt "PiggyBack" card)
- Two RS232 ports, one parallel
- Clock/calendar
- Printer Buffer
- Game Port
- RAM disk

Simply The Best \$ CALL

QUME'S SUPERIOR

HALF-HEIGHT 320K DRIVE

QUMETRAK 142 FEATURES CERAMIC R/W
HEAD, ADVANCED STEEL BAND HEAD
POSITIONER & 4 DRIVE DAISY CHAIN
CAPABILITY \$ 249.00

KEY TRONIC, INC.

Enhanced Word Processing Keyboard
Model KB-5150
Familiar key placement for touch-typists. Key
legends instead of obscure symbols \$ 199.00

IBM-PC SOFTWARE

MULTIPLAN

dBASE II \$ 206.95

EASY WRITER II \$ 468.75

PFS FILE \$ 105.00

PFS REPORT \$ 93.75

TOP 10 HIT PARADE

WORDSTAR \$ 322.50

HOME ACCOUNTANT PLUS \$ 103.50

EASY FILER \$ 275.00

LOTUS 1, 2, 3 \$ CALL

PFS GRAPH \$ 105.00

COLUMBIA DATA SYSTEMS

ENHANCED IBM ALTERNATIVE

IBM Hardware & Software compatibility in a Multi-user 16 Bit computer. 128K two
serial ports, one parallel port and 8 expansion slots. Runs MS-DOS, CP/M 86 or MP M
86. OASIS-16 MS-DOS "Super-Pak" includes Macro-Assembler, Diagnostics, Basica w
colorgraphics PLUS Perfect Writer, Speller, Calc and File, Fast Graph & Space
Commanders \$ CALL

MILE-HIGH SAVER BYTEWRITER 30 BY OLIVETTI

LETTER QUALITY PRINTER \$579.00 ELECTRONIC SELF-CORRECTING TYPEWRITER

APPLE/FRANKLIN HARDWARE FRANKLIN ACES-THE APPLE II+//IE ALTERNATIVES

ACE 1000 (64K)

Upper & Lower Case
Automatic Key Repeat
Numeric Keypad
Larger power supply with fan
Call for Special package price

Micro-SCI A2 Disk Drive \$ 249.00

RANA SYSTEMS - ELITE SERIES

300% Faster than Disc II

Elite I (up to 163K) \$ 289.00

Elite II & III \$ CALL

Compatible Controller Card \$ 55.00

VISTA COMPUTER CO. INC.

PRESENTS THE V1200:

Removable mass storage for your AppleII
6 meg (formatted) per 5 disc cartridge. Comes
complete w/drive, cable, controller, software
and one 6 meg Vistapak cartridge.

All for only \$1195.00

RAM EXPANSION

Davong (16K) \$ 49.95

Microsoft (16K) \$ 75.00

Microtek (BAM 16K) \$ 73.00

80 COLUMN CARDS

ALS, Smarterm II \$ 129.00

Videx, UltraTerm \$ CALL

UltraTerm ComboPkg \$ 265.00

Vista, Vison 80 \$ 239.00

PRINTER INTERFACES/BUFFERS

Microtek, RV611C par \$ 63.00

Apple Dumping 16K \$ 160.00

Orange Micro, Grappier+ \$ 119.00

Buffered Grappier+ \$ 189.00

ACE 1200 (128K)

Move over IIE!
Has everything the 1000 has plus:
Z80 Card (CP/M) + 80 columns
Built-in drive, built-in color
Serial & Parallel Interfaces \$ CALL

Micro Buffer II \$ 209.00

VIDEX PS10 Dual Function Card

Modem and Printer Ports \$ 169.00

MISCELLANEOUS

ALF PRODUCTS, INC. 8088 Processor:
Powerful "IBM" chip on a card: \$ CALL

ANTI-STATIC TOUCH MATS \$ 89.00

KENSINGTON, System Saver \$ 72.00

KRAFT, Joystick \$ 48.00

Paddles \$ 32.00

M & R ENTERPRISES

Sup'r Mod Universal \$ 55.00

Sup'r Fan \$ 38.00

MICROSOFT

Z80 with CP/M \$ 245.00

Softcard Premium Pack \$ 495.00

Softcard Plus (Franklin) \$ 445.00

T & G PRODUCTS

Joystick \$ 42.00

Game Paddles \$ 28.00

Select-a-port \$ 42.00

Trak-Ball \$ 47.00

VIDEX, Enhancer II \$ 119.00

Function Strip \$ 62.00

Enhancer, Rev. 6 \$ 99.00

WICO, Joystick \$ 22.00

WHAT'S NEW FOR IBM-PC COLUMBIA DATA SYSTEMS PORTABLE:

COLUMBIA 1600-VP

256K, 2 320K Slim Line Drives, 9" Monitor, comes w/MS-DOS Super Pak (as described in
Columbia Data Systems section). 18" x 16" x 8" with cover. Weighs 32 lbs. Centronics
compatible. \$ CALL

PRINTERS - DOT MATRIX

C-ITOH
Prowriter I - par \$ CALL
Prowriter II - par \$ CALL

EPSON

FX-80 \$ CALL

IDS, Prism \$ CALL

Microprism \$ CALL

OKIDATA

82A \$ 419.00

83A \$ 706.00

84 par \$1055.00

92 par \$ 539.00

93 par \$ 927.00

STAR MICRONICS

Gemini 10 \$ CALL

Gemini 10X \$ CALL

QUANTEX

7030 (Dot Letter Quality) \$1695.00

LETTER QUALITY

BROTHER HR-1 \$ 884.00

BYTEWRITER (W/KEYBOARD) \$ 599.00

C-ITDH
Starwriter F-10-40, par \$1195.00

NEC

7710, 7730 \$2291.00

3550 IBM plug-in \$1899.00

COLOR INK JET

CANON A1210 7 color 30 shades \$ 635.00

MONITORS

AMDEK, 300 Amber \$ 159.00

300 Green \$ 155.00

310 A, G-IBM including cable \$ 179.00

Color I composite \$ 299.00

Color II RGB (IBM compatible) \$ 495.00

NEC, 1201 Hi-Res, Green \$ 161.00

1203 RGB (IBM compatible) \$ 635.00

TAXAN Amber \$ 129.00

Green \$ 119.00

USI Amber Hi-Res \$ 155.00

ZENITH Green Med Res \$ 118.00

DISKETTES & STORAGE

ELEPHANT 10 each 5 1/4 SS DD \$ 19.95

10 each 5 1/4 DS DD \$ 26.95

MAXELL 10 each 5 1/4 SS/DD \$ CALL

10 each 5 1/4 DS/DD \$ CALL

VERBATIM 10 each 5 1/4 SS DD \$ 25.95

10 each 5 1/4 DS DD \$ 36.95

12 each 5 1/4 SS DD \$ 19.95

ZIMAG LIBRARY CASE, 5 1/4 \$ 2.50

DISK BANK, 5 1/4 interlock & swivel \$ 5.50

DISK FILE, 5 1/4 Elephant "Trunk" \$ 21.95

NEC APC

Advanced Personal Computer. Standard 128K RAM-expands to 256K.
1 Megabyte storage per disk. Available with two on-board drives.
Excellent detached keyboard with keypad. 22 programmable function
keys. Superior Resolution: 640 x 475 CALL for system quote.

MODEMS

ANCHOR AUTOMATION

Signalman Mark 1 \$ 83.00

HAYES

Smartmodem 300 \$ 211.00

Smartmodem 1200 \$ CALL

Micromodem II \$ 275.00

NOVATION

CAT (Acoustic) \$ 153.00

D-CAT \$ 168.00

J-CAT \$ 123.00

Auto Cat \$ 219.00

Apple Cat II \$ 273.00

212 Module (1200 baud opt. for Apple Cat II) \$ 354.00

212 Apple Cat II (1200 baud) \$ 626.00

VISIT OUR
WAREHOUSE OUTLET STORE

Rocky Mountain Micro, Inc.

MAIL ORDERS: 10890 E. 47th Ave.
Denver, Colorado 80239

TERMS AND CONDITIONS:

- NO CREDIT CARD FEE
- Personal checks (allow 10 days to clear). Visa, Master Card, wire transfers, include telephone number
- COD orders accepted - \$300 maximum - \$10 nonrefundable surcharge - All products factory sealed with manufacturer's warranty
- PO's accepted from qualified customers - Approval needed on all returns - 10% restocking charge unless defective plus shipping
- All Colorado residents add 3.5% sales tax. City & County of Denver residents additional 3.6% sales tax
- Shipping, Handling & Insurance \$5.00 minimum, 4% UPS ground; UPS Blue Label rate quoted at time of order
- All prices subject to change without notice
- Export orders accepted from foreign dealers. Contact F. L. Kleinberg & Co. TWX 910-340-2517
- Telephone Order/Desk Hours: 8 AM to 6 PM, Monday through Friday, 10 AM to 4 PM Saturday, Mountain Standard Time

NATIONAL
ORDER
DESK:

1-800-862-7819

IN COLORADO CALL: 303-371-2430

TECH ASSIST. & CUSTOMER SERVICE
CALL 303-371-2430

YOUR SATISFACTION IS OUR
BEST ADVERTISING!
WE SERVICE WHAT WE SELL

Main/Frames

Main/Frames

from
\$200

- 30 Models of Enclosures
- Assembled and tested
- Quasi-Coax Motherboards
- Power Supply
- Card cage and guides
- Fan, line, cord, fuse, power & reset switches

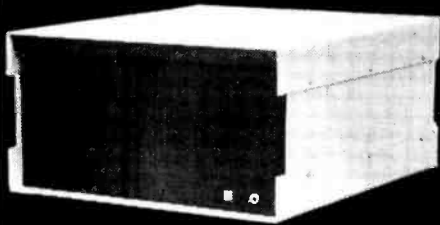

8" Floppy Main/Frame
\$482

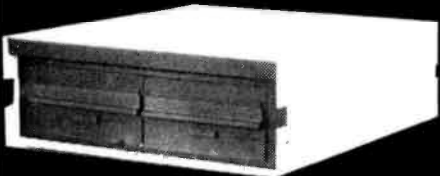

8" Disc Enclosure
\$250

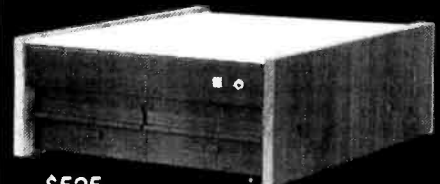

\$525
Phase/80 8" Floppy Mainframe



\$900
Phase/80 Desk + Mainframe

Write or call for our brochure which includes our application note:

"Building Computers — A Recipe"

INTEGRAND

8620 Roosevelt Ave. • Visalia, CA 93291
209/654-4203

We accept BankAmericard/Visa and MasterCard

Listing 1 continued:

```

1B4B: 2A          91          ROL A          ;ROTATE LEFT TWICE
1B4C: 08          92          PHP           ;SAVE CARRY
1B4D: 4A          93          LSR A         ;SHIFT RIGHT ONCE
1B4E: 95 19       94          STA STARTZ,X  ;STORE SHIFTED PATTERN
1B50: CA          95          DEX           ;
1B51: E0 FF       96          CPX #5FF      ;ROTATED EACH BYTE?
1B53: D0 F2       97          BNE LOOP4     ;NO, LOOP
1B55: 28          98          PLP           ;KEEP STACK IN ORDER
1B56: 88          99          DEY           ;
1B57: D0 EA       100         BNE LOOP3     ;LOOP IF Y<0
1B59:             101 *
1B59:             102 * CALCULATE HI-RES SCREEN ADDRESS FOR FIRST BYTE TO
1B59:             103 * BE USED IN LINE YCOORD
1B59:             104 *
1B59: A4 E3       105 SKIP      LDY YCOORD
1B5B: B9 B3 1D     106         LDA LOSTRT,Y
1B5E: 18          107         CLC           ;
1B5F: 65 EF       108         ADC ADDRADD
1B61: 85 ED       109         STA ADDRLL
1B63: B9 73 1E    110         LDA HISTRT,Y
1B66: 69 00       111         ADC #500
1B68: 85 EE       112         STA ADDRHH   ;GET ADDR FOR 1ST BYTE
1B6A:             113 *
1B6A:             114 * MOVE SHIFTED BYTES FROM ZERO PAGE TO HI-RES SCREEN
1B6A:             115 * MEMORY. FOR NON-EXCLUSIVE-OR PLOTTING, CHANGE
1B6A:             116 * 'EOR (ADDRLL),Y' TO 'ORA (ADDRLL),Y' (OPCODE 511).
1B6A:             117 *
1B6A: A0 00       118         LDY #500
1B6C: A6 FB       119         LDX WIDTH
1B6E: B5 19       120 LOOP5     LDA STARTZ,X
1B70: 51 ED       121         EOR (ADDRLL),Y
1B72: 91 ED       122         STA (ADDRLL),Y ;PLOT BYTE ON SCREEN
1B74: C8          123         INY          ;
1B75: CA          124         DEX          ;
1B76: E0 FF       125         CPX #5FF     ;THROUGH PLOTTING LINE?
1B78: D0 F4       126         BNE LOOP5   ;NO, LOOP
1B7A: E6 E3       127         INC YCOORD  ;YES, GO TO NEXT LINE
1B7C: A5 E3       128         LDA YCOORD
1B7E: C5 FD       129         CMP ENDLN   ;MORE LINES?
1B80: D0 AD       130         BNE LOOP1   ;YES, LOOP
1B82: 60          131         RTS         ;NO, RETURN
1B83:             132 QUOTBL  EQU *
1B83:             133 LOSTRT  EQU *+560
1B83:             134 HISTRT  EQU *+752
    
```

*** SUCCESSFUL ASSEMBLY: NO ERRORS

Listing 2: Lookup tables used by the listing 1 subroutine.

```

1B83- 00 00 00 01 00 02 00 03 00 04 00 05 00
1B90- 06 01 00 01 01 01 02 01 03 01 04 01 05 01 06 02
1BA0- 00 02 01 02 02 02 03 02 04 02 05 02 06 03 00 03
1BB0- 01 03 02 03 03 03 04 03 05 03 06 04 00 04 01 04
1BC0- 02 04 03 04 04 04 05 04 06 05 00 05 01 05 02 05
1BD0- 03 05 04 05 05 05 06 06 00 06 01 06 02 06 03 06
1BE0- 04 06 05 06 06 07 00 07 01 07 02 07 03 07 04 07
1BF0- 05 07 06 08 00 08 01 08 02 08 03 08 04 08 05 08
1C00- 06 09 00 09 01 09 02 09 03 09 04 09 05 09 06 0A
1C10- 00 0A 01 0A 02 0A 03 0A 04 0A 05 0A 06 0B 00 0B
1C20- 01 0B 02 0B 03 0B 04 0B 05 0B 06 0C 00 0C 01 0C
1C30- 02 0C 03 0C 04 0C 05 0C 06 0D 00 0D 01 0D 02 0D
1C40- 03 0D 04 0D 05 0D 06 0E 00 0E 01 0E 02 0E 03 0E
1C50- 04 0E 05 0E 06 0F 00 0F 01 0F 02 0F 03 0F 04 0F
1C60- 05 0F 06 10 00 10 01 10 02 10 03 10 04 10 05 10
1C70- 06 11 00 11 01 11 02 11 03 11 04 11 05 11 06 12
1C80- 00 12 01 12 02 12 03 12 04 12 05 12 06 13 00 13
1C90- 01 13 02 13 03 13 04 13 05 13 06 14 00 14 01 14
1CA0- 02 14 03 14 04 14 05 14 06 15 00 15 01 15 02 15
1CB0- 03 15 04 15 05 15 06 16 00 16 01 16 02 16 03 16
1CC0- 04 16 05 16 06 17 00 17 01 17 02 17 03 17 04 17
1CD0- 05 17 06 18 00 18 01 18 02 18 03 18 04 18 05 18
1CE0- 06 19 00 19 01 19 02 19 03 19 04 19 05 19 06 1A
1CF0- 00 1A 01 1A 02 1A 03 1A 04 1A 05 1A 06 1B 00 1B
1D00- 01 1B 02 1B 03 1B 04 1B 05 1B 06 1C 00 1C 01 1C
1D10- 02 1C 03 1C 04 1C 05 1C 06 1D 00 1D 01 1D 02 1D
1D20- 03 1D 04 1D 05 1D 06 1E 00 1E 01 1E 02 1E 03 1E
1D30- 04 1E 05 1E 06 1F 00 1F 01 1F 02 1F 03 1F 04 1F
1D40- 05 1F 06 20 00 20 01 20 02 20 03 20 04 20 05 20
1D50- 06 21 00 21 01 21 02 21 03 21 04 21 05 21 06 22
1D60- 00 22 01 22 02 22 03 22 04 22 05 22 06 23 00 23
1D70- 01 23 02 23 03 23 04 23 05 23 06 24 00 24 01 24
1D80- 02 24 03 24 04 24 05 24 06 25 00 25 01 25 02 25
1D90- 03 25 04 25 05 25 06 26 00 26 01 26 02 26 03 26
1DA0- 04 26 05 26 06 27 00 27 01 27 02 27 03 27 04 27
1DB0- 05 27 06 00 00 00 00 00 00 00 00 00 00 00 00 00
1DC0- 80 80 80 00 00 00 00 00 00 00 00 80 80 80 80 80
1DD0- 80 80 80 00 00 00 00 00 00 00 00 80 80 80 80 80
1DE0- 80 80 80 00 00 00 00 00 00 00 00 80 80 80 80 80
1DF0- 80 80 80 28 28 28 28 28 28 28 28 80 80 80 80 80
1F00- A8 A8 A8 28 28 28 28 28 28 28 28 A8 A8 A8 A8 A8
1F10- A8 A8 A8 28 28 28 28 28 28 28 28 A8 A8 A8 A8 A8
1F20- A8 A8 A8 28 28 28 28 28 28 28 28 A8 A8 A8 A8 A8
1F30- A8 A8 A8 50 50 50 50 50 50 50 50 D0 D0 D0 D0 D0
1F40- D0 D0 D0 50 50 50 50 50 50 50 50 D0 D0 D0 D0 D0
    
```

Listing 2 continued on page 303

SuperSoft FORTRAN

Now for CP/M-86®, MS DOS, and IBM PC DOS®

SuperSoft FORTRAN is the answer to the growing need for a high quality FORTRAN compiler running under CP/M-86 and IBM PC DOS. It has major advantages over other FORTRAN compilers for the 8086. For example, consider the benchmark program used to test the IBM FORTRAN in InfoWorld, p. 44, Oct. 25, 1982. (While the differential listed will not be the same for all benchmark programs, we feel it is a good indication of the quality of our compiler.) Results are as follows:

IBM FORTRAN: 38.0 Seconds
SuperSoft FORTRAN: 2.8 Seconds

In its first release SuperSoft FORTRAN offers the following outstanding features:

1. Full ANSI 66 standard FORTRAN with important extensions
2. Standard data types, double precision, varying string length, complex numbers
3. Free format input and free format string output
4. Compact object code and run time support
5. Special functions include string functions, dynamic allocation, time/date, and video access
6. Debug support: subscript checking, good runtime messages
7. Full IEEE floating point
8. Full 8087 support—available as option (\$50.00).

Program developers:

SuperSoft's family of FORTRAN compilers means you can write your programs once and they will run under CP/M-80, CP/M-86, and MS DOS. This lets you get your applications running fast no matter what the environment.

The current compiler allows 64K code space and 64K data space with expansion anticipated in future releases.



"At last, a FORTRAN compiler that works great on my 8086, 8087, and 8088 based systems!"

SuperSoft FORTRAN: available NOW and working great!

Requires: 128K with CP/M-86® and MS DOS

Price: \$425 (in each environment)
CP/M-80 version also available.

In conjunction with SuperSoft, SuperSoft FORTRAN was developed by Small Systems Services, Urbana, IL, a leader in FORTRAN development.

CP/M and CP/M-86 are registered trademarks of Digital Research.

Japanese Distributor: ASR Corporation International, 3-23-8, Nishi-Shimbashi, Minato-Ku, Tokyo 105, Japan, Tel. (03)-437571 Telex: 0242-2723.

European Agent: Micro Technology Ltd., 51 The Pantiles, Tunbridge Wells, Kent, England TN2 5TH TEL 0892-45433. Telex: 95441 Micro-G.

Circle 373 on Inquiry card.

SuperSoft®

FIRST IN SOFTWARE TECHNOLOGY P.O. Box 1628 Champaign, IL 61820 (217) 359-2112 Telex 270365

EROS

'Dedicated to Your Satisfaction!'

**LOW, LOW PRICES!
GREAT SERVICE!**

What more can you ask for!



PERIPHERALS FOR ALL COMPUTERS

PRINTERS:

STAR MICRONICS:
 Gemini prices too low to print! **SCALL**
 Gemini 10X:
 The improved & updated 10 **SCALL**
 Gemini 15X **SCALL**

SMITH CORONA:
 TPI **SCALL**

C.I.TOH:
 Prowriter I \$ 369.00
 Prowriter II \$ 689.00
 F-10 Starwriter \$1150.00
 F-10 Printmaster **SCALL**

JUKI:
 The New! L/Q Printer
 18CPS \$ 539.00

OKIDATA:
 Microline 92 \$ 499.00
 Microline 93 \$ 849.00
CALL FOR PACEMARK PRICES!

HARD DISK DRIVES:

DAVONG:
 (IBM, Apple)
 5MB \$1339.00
 10MB \$1739.00
 15MB \$2139.00

PERCOM:
 (IBM, Apple, TRS-80)
 5MB
 10MB
 15MB
 20MB **SCALL** for lowest prices

DISKS:

NEW! Kangaroo: With library case
 and 10 year warranty!
 5 1/4" SS/DD (Box of 10) **\$19.50**
 5 1/4" DS/DD (Box of 10) **\$28.50**
 5 1/4" SS/DD (Box of 6) **\$14.50**
 5 1/4" DS/DD (Box of 6) **\$22.50**

Verbatim:
 5 1/4" SS/DD (Box of 10) **\$20.95**
 5 1/4" DS/DD (Box of 10) **\$29.95**
Dysan:
 5 1/4" SS/DD (Box of 10) **\$30.95**
 5 1/4" DS/DD (Box of 10) **\$38.95**

MONITORS:

Amdek:
 Color I \$299.00
 Color II \$499.00
 310G Green \$179.00
 310A Amber \$179.00
 300G Green \$144.00
 Taxan: Amber 12" \$144.00
Princeton Graphics System:
 RGB Hi-Res **\$Priced too low!**
 Zenith: ZVM 121 Green \$ 99.00

MODEMS:

Hayes:
 Micromodem II
 with terminal program ... **SCALL**
 without terminal program ... **SCALL**
 Smartmodem
 300 Baud \$209.00
 1200 Baud \$509.00
Novation:
 J-Cat \$119.00
 AppleCat II \$279.00
 SmartCat 1200 Baud **SCALL**
NEW! U.S. Robotics:
 Password **SCALL**

PULSATING SPECIALS!

M.B.I. Monte Carlo™ Card

GT™ - Five Functions
 Memory/Serial/Parallel/Clock
 and joystick ports **SCALL**

Quatro™ - Same features as the
 GT™ but without joystick ports
 **SCALL**

TANDON Disk Drives

TM-100-2
 320K Bytes **\$239.00**

Tandon or Shugart
 or Equivalent Thin Line:
 320K Bytes **SCALL**

COLUMBIA DATA PRODUCTS
MPC Personal Computer

Features:

- IBM PC Compatibility - 128K Ram -
- 16 Bit Processor
- 8 Expansion Slots: 2 RS232 1 Parallel
- Floppy and Winchester controllers built in

CALL FOR PRICES ON COLUMBIA'S NEW PORTABLE!

OTHER COMPUTERS WE ALSO STOCK:

Franklin ACE 1000/1200 Commodore 64K Panasonic JR200
Call for IBM PC and Apple IIe Prices

PRODUCTS FOR YOUR IBM-PC®:

MBI:
 I-C—MAGIC: Programmable Graphics Screen Dump Prom Chip **SCALL**

T&G Products:	Quadram Corporation:
Joysticks \$27.00	Quad Board: 64K SCALL
Trakball \$49.00	Microfazer SCALL
Kraft Products:	Maynard Electronics:
Joysticks \$55.00	Floppy Disk Controller:
Game Paddles \$33.00	Parallel \$209.00
	Serial \$239.00

SOFTWARE:

Infocom:	Continental:
Zork I \$27.00	Home Accountant Plus SCALL
Zork II \$27.00	Visicorp:
Zork III \$27.00	Visidex \$179.00
Deadline SCALL	Visifiles \$179.00
Lifetree Systems:	Visitrend/Plot \$225.00
Volkswriter SCALL	256K Visicalc \$179.00

PRODUCTS FOR YOUR APPLE®:

MBI:
 VIP Graphics Card \$119.00
 Appletime Clock Card \$ 85.00

EXPANSION CARDS:

Microsoft:
 16K Card \$ 79.00
 CP/M Z80 Card \$259.00
Generic:
 16K Card **SCALL**
Videx:
 80 Column Card
 with Softswitch \$269.00
 Advanced Logic Systems .. **SCALL**

SOFTWARE:

Continental:
 Home Accountant \$ 53.00
On-Line:
 Screenwriter II \$ 85.00
Silicon Valley Systems:
 Final Analysis \$134.00
 Word Handler \$125.00
VisiCorp:
 Visidex \$180.00
 Visifiles \$180.00
 Visicalc \$180.00
T&G Products:
 Joysticks \$ 42.00
 Game Paddles \$ 28.00
Kraft:
 Joysticks \$ 49.00
 Game Paddles \$ 33.00

EROS

For a Great Time, Call: 1-800-533-8987
P.O. Box 22573 • Minneapolis, MN 55422 • 1-612-529-7139

Circle 166 on inquiry card.

TERMS AND CONDITIONS: Payment: Personal checks are accepted although cashier's checks and money orders will be shipped first. VISA and Mastercard accepted—add 4% to total. Shipping: We calculate exact freight—for mail-in orders add 3% UPS GRD, 4% UPS BLUE - Monitors minimum \$8.00. Delivery: ASAP with 2-4 weeks on average. Price List: Features all of our up-to-date pricing. General: We replace or repair faulty goods at our discretion—refunds only at our discretion—no returns on software.

(1a)	Coordinate	6502 Register
x	low-order byte	X
x	high-order byte	Y
y		A

(1b)	Address Byte	Memory Location
	low-order byte	EB
	high-order byte	EC

Table 1: Summary of parameters that must be set up prior to calling the shape subroutine: coordinates of upper left corner of bit picture (1a) and starting address (hexadecimal) of shape table (1b).

Text continued from page 298:

tion. A summary of the parameter setup is given in table 1.

The subroutine works by taking the exclusive-OR of each affected bit in page-1 hi-res screen memory with the corresponding bit of the bit picture. This exclusive-OR plotting has several advantages. First, a color need not be specified; the shape is drawn by calling the subroutine once and is erased by simply calling it again with the same screen coordinates. Second, any shape drawn using exclusive-OR plotting is nondestructive; that is, whatever the shape happens to plot over is restored when the shape is erased. This property can be used to form interesting backgrounds that need not be redrawn after shapes are plotted and moved on top of them. Cross-hair cursors are also free to move around without destroying the screen's previous contents.

Several details about the subroutine need to be explained. Zero page (hexadecimal locations 00 through FF) of memory is used for temporary storage; the particular locations used were chosen to avoid destruction of locations used by the Apple Monitor, Applesoft, Integer Basic, and the DOS (disk operating system). The subroutine does not operate correctly without the tables shown in listing 2. These tables may be stored anywhere in memory, but are best located immediately after the subroutine in memory. Three pertinent

Text continued on page 306

Listing 2 continued:

```

1F50- 00 00 00 50 50 50 50 50 50 50 50 00 00 00 00 00
1F60- 00 00 00 50 50 50 50 50 50 50 50 00 00 00 00 00
1F70- 00 00 00 20 24 28 2C 30 34 38 3C 20 24 28 2C 30
1F80- 34 38 3C 21 25 29 2D 31 35 39 3D 21 25 29 2D 31
1E90- 35 39 3D 22 26 2A 2E 32 36 3A 3E 22 26 2A 2E 32
1FA0- 36 3A 3E 23 27 2B 2F 33 37 3B 3F 23 27 2B 2F 33
1FB0- 37 3B 3F 20 24 28 2C 30 34 38 3C 20 24 28 2C 30
1FC0- 34 38 3C 21 25 29 2D 31 35 39 3D 21 25 29 2D 31
1FD0- 35 39 3D 22 26 2A 2E 32 36 3A 3E 22 26 2A 2E 32
1FE0- 36 3A 3E 23 27 2B 2F 33 37 3B 3F 23 27 2B 2F 33
1FF0- 37 3B 3F 20 24 28 2C 30 34 38 3C 20 24 28 2C 30
1F00- 34 38 3C 21 25 29 2D 31 35 39 3D 21 25 29 2D 31
1F10- 35 39 3D 22 26 2A 2E 32 36 3A 3E 22 26 2A 2E 32
1F20- 36 3A 3E 23 27 2B 2F 33 37 3B 3F 23 27 2B 2F 33
1F30- 37 3B 3F

```

Listing 3: This shape-editor program forms a shape table directly from a high-resolution screen image.

```

100 TEXT : HOME : POKE - 16298,0: POKE - 16300,0
110 RESTORE : FOR I = 768 TO 774: READ J: POKE I,J: NEXT I: POKE 232,0: POKE 23
    3,3: DATA 1,0,3,0,45,5,0
120 DIM S$(105),T$(212)
130 XMAX = 42:YMAX = 35:ML = 101:MT = 10
140 HS = "0123456789ABCDEF"
150 DS = CHR$(4)
160 GOSUB 3100: GOSUB 3300: GOSUB 3400
400 REM SHOW CURSOR POSITION ON GRID
410 XDRAW 1 AT CL + 1,CT + 3
420 REM WAIT FOR KEYBOARD COMMAND
430 Q = PEEK (- 16384): IF Q < 128 THEN 430
440 POKE - 16368,0:Q = Q - 128
500 REM
501 REM CURSOR MOVEMENT COMMANDS
502 REM
510 IF Q < > ASC ("I") THEN 550
520 XDRAW 1 AT CL + 1,CT + 3
530 IF Y > 1 THEN Y = Y - 1:CT = CT - 4
540 GOTO 410
550 IF Q < > ASC ("M") THEN 590
560 XDRAW 1 AT CL + 1,CT + 3
570 IF Y < YMAX THEN Y = Y + 1:CT = CT + 4
580 GOTO 410
590 IF Q < > ASC ("J") THEN 630
600 XDRAW 1 AT CL + 1,CT + 3
610 IF X > 1 THEN X = X - 1:CL = CL - 4
620 GOTO 410
630 IF Q < > ASC ("K") THEN 700
640 XDRAW 1 AT CL + 1,CT + 3
650 IF X < XMAX THEN X = X + 1:CL = CL + 4
660 GOTO 410
700 REM
701 REM PLOT COMMAND
702 REM
710 IF Q < > ASC ("P") THEN 810
720 ELE = INT ((X - 1) / 14) + 3 * (Y - 1)
730 BIT = (X - 1) - INT ((X - 1) / 14) * 14
740 A = INT (S$(ELE) / 2 ^ BIT)
750 IF A / 2 < > INT (A / 2) THEN 810
760 S$(ELE) = S$(ELE) + 2 ^ BIT
770 FOR I = 2 TO 4: XDRAW 1 AT CL + 1,CT + I: NEXT I
780 HCOLOR= 7: HPLLOT 29 + X,62 + Y
790 GOTO 430
800 REM
801 REM ERASE COMMAND
802 REM
810 IF Q < > ASC ("E") THEN 900
820 ELE = INT ((X - 1) / 14) + 3 * (Y - 1)
830 BIT = (X - 1) - INT ((X - 1) / 14) * 14
840 A = INT (S$(ELE) / 2 ^ BIT)
850 IF A / 2 < > INT (A / 2) THEN 900
860 S$(ELE) = S$(ELE) - 2 ^ BIT
870 FOR I = 2 TO 4: XDRAW 1 AT CL + 1,CT + I: NEXT I
880 HCOLOR= 0: HPLLOT 29 + X,62 + Y
890 GOTO 430
900 REM
901 REM CLEAR SCREEN COMMAND
902 REM
910 IF Q < > ASC ("C") THEN 1030
920 XDRAW 1 AT CL + 1,CT + 3
930 VTAB 23: PPRINT "SURE YOU WANT TO ERASE THE SCREEN?"
940 GOSUB 3500
950 VTAB 22: CALL - 959: IF Q < > ASC ("Y") THEN 410
960 FOR I = 0 TO 105:S$(I) = 0: NEXT I
970 GOSUB 3300: GOSUB 3400: GOTO 410
1000 REM
1010 REM TABLE COMMAND
1020 REM
1030 IF Q < > ASC ("T") THEN 1520
1040 VTAB 23: PRINT "SET CURSOR TO TOP LEFT CORNER OF": PRINT "DESIRED BIT MAP
    AND HIT RETURN";
1050 L5 = 1

```

Listing 3 continued on page 304

CompuPro

SYSTEMS CENTER

System 8/16A \$4495
 System 8/16B \$5395
 System 8/16C \$6895

* Fully Assembled and Burned-in *
 All Systems include SORCIM'S SUPERWRITER,
 SPELL CHECKER, MAIL LIST & FORM LETTER
 PROGRAMS.

MORROW

MICRODECISION II OR III

Now includes
 QUEST ACCOUNTING SYSTEM \$1170
 \$1470

FOLLOW THE STAR

HORIZON 64 K-2QD
 w/NORTHWORD & INFO-MNGR. \$2695

Cromemco C-10 \$1525

EAGLE II with S.W. \$1595

Access

Complete portable w/64 K RAM, 7" AMBER, 2
 DRV., 2 MODEMS, MX80 PRINTR, Sep. K.B.,
 GRAPHICS w/Lots of S.W. & Tutorials, USI 12"
 AMBER MON. + MANY Options available
 \$2495

PERIPHERALS - BOARDS:

PC MATE by **TECMAR** FOR IBM
 1st MATE 64 K + SERIAL + \$295
 2nd MATE 2 SERIAL / 2 PARA. + \$229

Lab Quality D/A & A/D BO.S for IBM-PC
 & S-100 BUS

VOTRAX SPEECH SYSTEM \$275
 SSM TRANSMODEM 1200 \$495
 BY RACAL VADIC

PRINTERS:

C. itoh 1550 SERIAL \$750
 TALLY MT 160L CALL
 EPSON CALL
 OKIDATA 82A \$439

FLOPPY DISK DRIVES

Tandon 100-2 5 1/4" DSDD \$239

Qume 842 8" DSDD \$460
 242 8" DSDD \$445
 142 5 1/4" DSDD \$190

IBM has recently selected the QUME Drive for
 their PC.

FULL DEALER SUPPORT
VISIT OUR SHOWROOM
Hrs. 9:00 A.M. - 5:30 P.M. M-F
 Subject to Available Quantities
 Prices Quoted include Cash Discounts
 Shipping & Insurance Extra

 S-100
 Established 1977

14425 North 79th Street, Suite B
 Scottsdale, Arizona 85260
 TELEX 185025
 TECHNICAL 602-991-7870
 SALES 800-528-3138

Circle 346 on Inquiry card.

Listing 3 continued:

```

1060 GOTO 430
1070 PL = X:PT = Y
1080 VTAB 22: CALL - 958: PRINT : PRINT "SET CURSOR TO BOTTOM RIGHT CORNER OF"
: PRINT "DESIRED BIT MAP AND HIT RETURN";
1090 L5 = 2
1100 GOTO 430
1110 PR = X:PB = Y:L5 = 0
1120 XDRAW 1 AT CL + 1,CT + 3
1130 VTAB 22: CALL - 958
1140 IF PL > PR OR PT > PB THEN VTAB 23: HTAB 1: POKE 50,63: PRINT "ILLEGAL BI
T MAP CORNERS": POKE 50,255: FOR I = 1 TO 2000: NEXT I: VTAB 22: CALL - 95
8: GOTO 410
1150 VTAB 23: HTAB 1: PRINT "NOW FORMING SHAPE TABLE"
1160 FOR I = 0 TO 212:T%(I) = 0: NEXT I
1170 L = PB - PT + 1:W = (PR - PL + 1) / 7: IF W < > INT (W) THEN W = INT (W)
+ 1
1180 T%(0) = L:T%(1) = W:N = 2:Q = 0
1190 FOR Y = PT TO PB
1200 FOR X = PL TO PL + W * 7 - 1
1210 IF X > PR THEN BN = 0: GOTO 1250
1220 FLE = INT ((X - 1) / 14) + 3 * (Y - 1)
1230 BIT = (X - 1) - INT ((X - 1) / 14) * 14
1240 BN = 0:A = INT (5%(FLE) / 2 ^ BIT): IF INT (A / 2) < > A / 2 THEN BN = 1
1250 IF BN = 1 THEN T%(N) = T%(N) + 2 ^ Q
1260 Q = Q + 1: IF Q = 7 THEN Q = 0:N = N + 1
1270 NEXT X: NEXT Y
1280 HOME : POKE - 16303,0
1290 VTAB 2: PRINT "DO YOU WANT TO SEE THE TABLE IN HEX": PRINT " OR IN DECIM
AL?": PRINT : PRINT
1300 GOSUB 3500
1310 IF Q < > ASC ("D") AND Q < > ASC ("H") THEN 1280
1320 Z = 0: FOR I = 0 TO L * W + 1
1330 Z = Z + 1
1340 IF Q = ASC ("D") THEN PRINT TAB ( Z * 4 );T%(I);: GOTO 1360
1350 PRINT TAB ( Z * 3 ); MIDS (HS, INT (T%(I) / 16) + 1,1); MIDS (HS,T%(I) - I
NT (T%(I) / 16) * 16 + 1,1);
1360 IF Z = 8 THEN Z = 0: PRINT
1370 NEXT I
1380 PRINT : PRINT : IF PEEK (37) < 21 THEN POKE 34, PEEK (37)
1390 PRINT "DO YOU WANT TO SAVE THE OBJECT TABLE": PRINT " ON DISK?"
1400 GOSUB 3500
1410 IF Q < > ASC ("Y") THEN 1470
1420 PRINT : PRINT "WHAT DO YOU WANT TO NAME": INPUT " THE FILE? ";NS
1430 FOR I = 0 TO L * W + 1: POKE 16384 + I,T%(I): NEXT I
1440 PRINT DS;"BSAVE";NS;"AS4000,L";L * W + 2
1450 PRINT "FILE SAVED USING NAME ";NS
1460 PRINT : PRINT : GOTO 1390
1470 POKE 34,0: HOME : VTAB 2: PRINT "DO YOU WANT TO RETURN TO THE": PRINT "
SCREEN EDIT MOOF?"
GOSUB 3500
1480 IF Q < > ASC ("Y") THEN 2260
1490 GOSUB 3100: POKE - 16304,0: GOSUB 3310: GOTO 410
1510 REM 'RETURN' PSEUDO-COMMAND
1520 IF Q < > 13 THEN 1600
1530 ON L5 + 1 GOTO 430,1070,1110
1600 REM
1601 REM SAVE TABLE COMMAND
1602 REM
1610 IF Q < > ASC ("S") THEN 1800
1620 XDRAW 1 AT CL + 1,CT + 3
1630 VTAB 23: INPUT "FILE NAME FOR SAVE? ";NS
1640 VTAB 24: PRINT "NOW SCANNING IMAGE";: HTAB 1
1650 Z1 = 0
1660 IF S%(Z1) = 0 AND Z1 < 105 THEN Z1 = Z1 + 1: GOTO 1660
1670 Z2 = 105
1680 IF S%(Z2) = 0 AND Z2 > 0 THEN Z2 = Z2 - 1: GOTO 1680
1690 IF Z1 > Z2 THEN Z1 = 0:Z2 = 1
1700 VTAB 24: PRINT "NOW SAVING IMAGE TO DISK";: VTAB 23: PRINT
1710 PRINT DS;"OPEN";NS: PRINT DS;"WRITE";NS
1720 PRINT Z1: PRINT Z2
1730 FOR I = Z1 TO Z2
1740 PRINT S%(I)
1750 NEXT I
1760 PRINT DS;"CLOSE";NS
1770 VTAB 22: CALL - 958: GOTO 410
1800 REM
1801 REM LOAD TABLE COMMAND
1802 REM
1810 IF Q < > ASC ("G") THEN 2100
1820 XDRAW 1 AT CL + 1,CT + 3
1830 VTAB 23: PRINT "SURE YOU WANT TO LOAD?"
1840 GOSUB 3500
1850 VTAB 22: CALL - 958: IF Q < > ASC ("Y") THEN 410
1860 VTAB 23: INPUT "FILE NAME FOR LOAD? ";NS
1870 PRINT DS;"OPEN";NS: PRINT DS;"READ";NS
1880 INPUT Z1: INPUT Z2
1890 FOR I = 0 TO Z1:S%(I) = 0: NEXT I: FOR I = Z2 TO 105:S%(I) = 0: NEXT I
1900 FOR I = Z1 TO Z2
1910 INPUT S%(I)
1920 NEXT I
1930 PRINT DS;"CLOSE";NS
1940 GOSUB 3300: GOSUB 3400
1950 VTAB 22: CALL - 958: VTAB 23: PRINT "NOW RETRACING IMAGE ON SCREEN"
1960 ELE = Z1:BIT = 0:CL = ML + 4 * ((ELE - INT (ELE / 3) * 3) * 14)
1970 CT = MT + 4 * INT (ELE / 3)
1980 A = INT (S%(ELE) / 2 ^ BIT): IF INT (A / 2) = A / 2 THEN 2000
1990 FOR I = 2 TO 4: XDRAW 1 AT CL + 1,CT + I: NEXT I: HPLT 30 + (CL - ML) / 4
,63 + (CT - MT) / 4
    
```

Listing 3 continued on page 306

Circle 231 on Inquiry card. —>

KEY TRONIC POLISHES THE APPLE II* KEYBOARD



Eleven Function Keys
Streamline Multiple
Key Operations

Full Shifting Capability

Keys in Familiar
Typewriter Locations

Numeric Pad

10 Foot Cable
For Portability

Enhance your APPLE II* Computer System with a Key Tronic keyboard peripheral. This detached, low-profile keyboard is plug-compatible with the existing keyboard socket of the Apple II. It also features reliable microprocessor electronics, solid-state capacitance switches, and positive tactile feedback.

Price: \$298.00

To Order Model KB-200 Call Toll Free
1-800-262-6006 (8am-4pm Pacific Standard Time).
Warranty information may be obtained, free of
charge, by writing to the address below.

 **key tronic**
THE RESPONSIVE KEYBOARD COMPANY

DEPT. EI • P.O. BOX 14687 • SPOKANE, WASHINGTON 99214 USA

AUTHORIZED DISTRIBUTORS:

BASIC TIME
Los Angeles, CA (213) 538-9711
(800) 323-8437

C.J. SALES, INC.
San Francisco, CA (415) 941-6892

J.C. SALES
Los Angeles, CA (213) 340-6136

DIGITAL ENTRY SYSTEMS, INC.
Boston, MA (617) 899-6111
COMPUTER-MATE, INC.
Dallas, TX (800) 442-4006 (Texas)
(800) 527-3643 (Continental U.S.)

COMPONENTS UNLIMITED, INC.
Lynchburg, VA (804) 384-6000

PERIPHERAL SUPPORT, INC.
Chicago, IL (312) 593-5900
SSE PRODUCTS, INC.
Elmont, NY (516) 872-9001
QED ELECTRONICS, INC.
Philadelphia, PA (215) 657-5600
RHINO SALES COMPANY
Brighton, MI (313) 227-1788

FUTURE ELECTRONICS, INC.
Montreal, Quebec (514) 694-7710
Ottawa, Ontario (613) 820-8313
Toronto, Ontario (416) 663-5563
Calgary, Alberta (403) 259-6408
Edmonton, Alberta (403) 486-0974
Vancouver, B.C. (604) 438-5545

Listing 3 continued:

```
2000 CL = CL + 4:BIT = BIT + 1:IF BIT < > 14 THEN 1980
2010 IF ELE > = 22 THEN GOSUB 3310:GOTO 410
2020 BIT = 0:ELE = ELE + 1
2030 IF ELE / 3 = INT (ELE / 3) THEN CL = ML:CT = CT + 4
2040 GOTO 1980
2100 REM
2101 REM HELP COMMAND
2102 REM
2110 IF Q < > ASC ("H") AND Q < > ASC ("/") AND Q < > ASC ("?") THEN 2200
2120 VTAB 21:CALL - 958:POKE - 16303,0
2130 GOSUB 3170
2140 POKE - 16304,0
2150 VTAB 20:PRINT:CALL - 958:HTAB 2:PRINT "ACTUAL SIZE";:HTAB 21:PRINT
"VIEWING WINDOW"
2160 GOTO 430
2200 REM
2201 REM QUIT COMMAND
2202 REM
2210 IF Q < > ASC ("Q") THEN 430
2220 XDRAW 1 AT CL + 1,CT + 3
2230 VTAB 23:PRINT "SURE YOU WANT TO QUIT?"
2240 GOSUB 3500
2250 IF Q < > ASC ("Y") THEN VTAB 22:CALL - 958:GOTO 410
2260 HOME:POKE - 16303,0:POKE - 16298,0:VTAB 24
2270 GOTO 9999
3000 REM
3010 PEM SUBROUTINES
3020 PEM
3100 HOME
3110 HTAB 15:PRINT "COMMAND MENU":HTAB 15:PRINT "-----"
3120 VTAB 4:PRINT "I,J,K,M";TAB(9);"CURSOR MOVEMENT":PRINT:PRINT "P";TAB
(9);"PLOT POINT AT CURSOR POSITION":PRINT
3130 PRINT "E";TAB(9);"ERASE POINT AT CURSOR POSITION":PRINT:PRINT "C";TA
B(9);"CLEAR SCREEN":PRINT
3140 PRINT "T";TAB(9);"MAKE SHAPE TABLE":PRINT:PRINT "S";TAB(9);"SAVE SH
APE SOURCE FILE TO DISK":PRINT
3150 PRINT "G";TAB(9);"GET SHAPE SOURCE FILE FROM DISK":PRINT:PRINT "H OR
?";TAB(9);"HELP (RETURN TO THIS MENU)"
3160 PRINT:PRINT "Q";TAB(9);"QUIT PROGRAM EXECUTION"
3170 VTAB 24:HTAB 10:PRINT "HIT SPACE TO EXIT MENU";
3180 GOSUB 3500:IF Q < > ASC (" ") THEN 3180
3190 VTAB 21:CALL - 958
3200 RETURN
3300 POKE 230,32:CALL 62450:HGR:SCALE=1:ROT=0
3310 PT=YMAX+1:PB=0:PL=XMAX+1:PR=0
3320 VTAB 21:HTAB 2:PRINT "ACTUAL SIZE";:HTAB 21:PRINT "VIEWING WINDOW";:C
ALL - 958:PRINT
3330 X=INT(XMAX/2):Y=INT(YMAX/2)
3340 MR=ML+XMAX*4:MB=MT+YMAX*4
3350 CL=ML+(X-1)*4:CT=MT+(Y-1)*4
3360 RETURN
3400 HCOLOR=7
3410 FOR I=ML TO MR STEP 4:HPLLOT I,MT TO I,MB:NEXT I
3420 FOR I=MT TO MB STEP 4:HPLLOT ML,I TO MR,I:NEXT I
3430 RETURN
3500 Q=PEEK(-16384):IF Q<128 THEN 3500
3510 POKE -16368,0:Q=Q-128
3520 RETURN
9999 END
```

Text continued from page 303:

tables are named QUOTBL, LOSTRT, and HISTRT. QUOTBL is a lookup table used internally by the subroutine to divide the *x*-coordinate by 7. LOSTRT and HISTRT are each 192 bytes long, and they contain the low- and high-order bytes of the address of the leftmost byte of each *y*-coordinate in page 1 of hi-res screen memory. For plotting on page 2 of the hi-res memory, a hexadecimal 20 should be added to each byte in the table HISTRT. Although I wanted the subroutine to be fully relocatable, I compromised this requirement in favor of additional speed. However, as I have written it, relocating the subroutine requires changing only the two locations referencing QUOTBL in lines 38 and 41 of listing 1.

A Note on Color

One of the most difficult aspects of using the Apple high-resolution graphics mode is trying to control the color of objects displayed on the screen. This difficulty arises because a color cannot be individually assigned to each pixel on the screen; the color depends instead on such factors as whether an object is drawn with pixels horizontally alternating between on and off and whether the on pixels have even or odd *x*-coordinates. Through careful programming and shape-table composition, you can control colors in this manner using the shape subroutine presented in this article. In newer Apples, however, two more colors are added to the hi-res screen by defining the previously unused high-order bit in hi-res screen

memory. Unfortunately, these colors cannot be easily displayed using the shape subroutine because the subroutine forces the extra bit in the hi-res screen to 0. For a complete description of color in the Apple hi-res screen, see page 19 of the *Apple II Reference Manual* (Cupertino: Apple Computer Inc., 1979).

The Shape-Editor Program

Although it is not difficult to form the shape table for a given shape, it is often time consuming. When writing a program that uses shapes, you rarely know in advance the exact pixel pattern that makes up the shape. Even if you know the pattern, you're probably not sure whether the shape will look good on the hi-res screen. It might take you hours to develop a suitable shape if you have to write out each trial on graph paper, form the shape table, and use the subroutine to display the shape before you can tell if it is satisfactory. This time-consuming method can bring the creative process to a halt. A more desirable situation would be one in which you could easily experiment with different shapes on the hi-res screen until you were satisfied with the results and then form the shape table directly from the screen image. I had this concept in mind when writing the shape-editor program shown in listing 3. The program features complete hi-res editing, both actual size and a blown-up view of the shape being drawn, disk storage of the current shape (the source file) for future editing, and assembly of a shape table from any portion of the current screen.

The editor program requires an Apple II with 32K bytes of memory, a disk drive, and Applesoft in ROM (read-only memory). When you run the program, the list of commands shown in photo 1 comes up on the screen. After you press the space bar, the left area of the screen becomes blank, and a grid appears on the right. The blank area is the "slate" on which you can draw different shapes actual size. Anything drawn also appears enlarged on the grid, making it easier to see details of the shape. Once the grid has been drawn, a

LMC's 32-Bit Virtual Memory MegaMicro Achieves New Price/Performance Breakthrough

LMC's MegaMicros are among the most powerful and expandable microcomputers ever offered. They provide main-frame or super-minicomputer performance at prices competitive with today's far less powerful 8- and 16-bit microcomputers. And, they are available for delivery now. A typical multiuser MegaMicro system which includes a half meg of RAM and 20 megs of fast (30 ms. average access time) winchester disk storage as well as UNIX, C and FORTRAN costs only \$15,000 (and even less with OEM or quantity discounts). These are true multiuser systems allowing one to thirty-two users simultaneously to address 16 megabytes of virtual storage per user process even with very little true RAM.

LMC Mega-series computers incorporate: the NS16032 central processing unit which has true 32-bit internal logic and internal data path configured on the multibus (IEEE 796) 16-bit interface (making hundreds of peripheral boards and products available); demand-paged virtual memory implemented in hardware; and hardware 64-bit double-precision floating point arithmetic. These features give the MegaMicro remarkable performance.

In addition, the NS16032 instruction set architecture is symmetrical making the processor ideally suited to high-level languages such as FORTRAN, C, and PASCAL and to structured modular programming. Consequently, LMC's MegaMicros make efficient use of large operating systems and are supplied with an implementation of UNIX that includes the Berkeley 4.1 enhancements to take advantage of demand-paged virtual memory. Also included are C and FORTRAN 77; PASCAL, PL/I, ADA and other high-level languages will be available soon as options.

OEMs who wish to run C or FORTRAN benchmarks are invited to send evaluation code to LMC. Full technical specifications and prices of LMC's MegaMicros are available on request.

LMC MegaMicros *The Logical Alternative*TM

* UNIX is a Trademark of Bell Laboratories



The Logical MicroComputer Company
140 South Dearborn, Chicago, IL 60603 USA (312) 580.0250 Telex: 270384 Cable: Lexecom

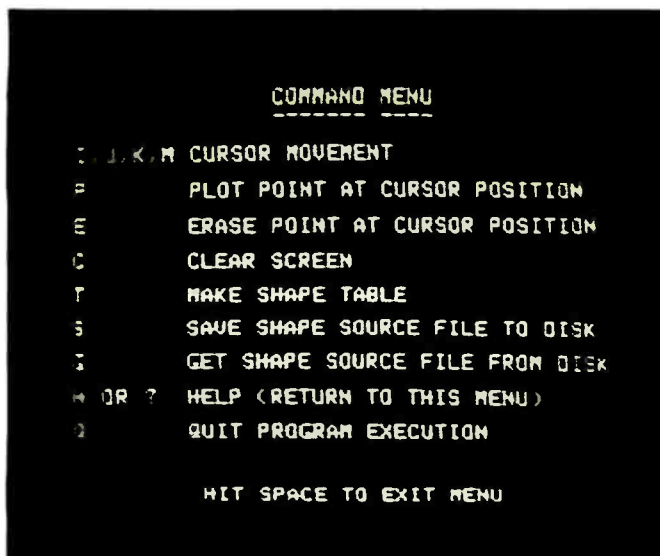

Photo 1: The command menu that appears at the beginning of the shape-editor program (listing 3). This menu also appears whenever the Help key is pressed.

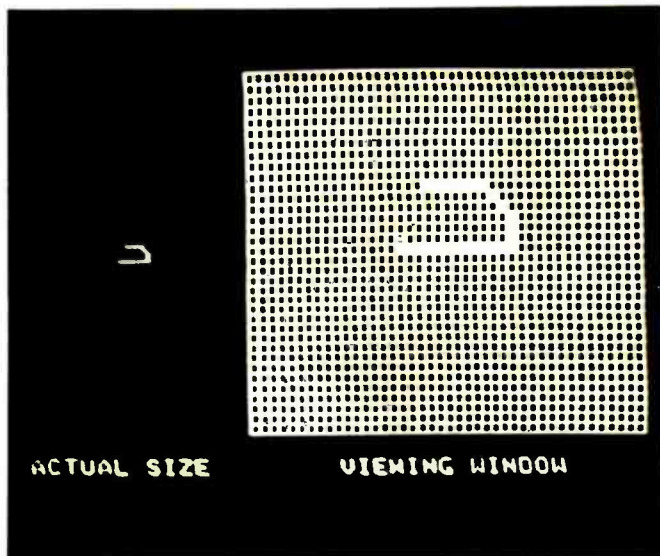

Photo 2: A view of the screen-edit mode of the shape-editor program. The figure on the grid is an enlarged view of the actual-size shape on the left side of the screen. The cursor is the small horizontal line in a square above the lower left corner of the displayed shape.

small horizontal line appears in one of the small squares in the grid. This is the cursor, which always shows the current drawing position of the program.

Once the cursor appears on the screen, you can execute any of the commands listed in the menu (photo 1) by pressing the corresponding letter on the keyboard. The letters I, J, K, and M are used for moving the graphics cursor up, left, right, and down, respectively. The Plot command plots a point at the current cursor position, and the Erase command erases the point at the current cursor position. Neither the Plot nor the Erase command causes any harm if the command has already been used at the cursor position (e.g., if the Plot

command is used at a position where a point already exists). The Clear command clears the screen after prompting you to verify that the screen should indeed be cleared. By using the cursor-movement, Plot, Erase, and Clear commands, you can draw the desired shape on the screen and modify it as many times as necessary. A shape being drawn in this screen-edit mode is shown in photo 2.

With the Table command, you can make a shape table from any segment of the screen where you have drawn a shape. After choosing the Table command by pressing the T key, you must choose the smallest rectangle that encloses the shape; this is the same rectangle chosen when forming

the shape table manually as previously described. You specify the boundaries of this rectangle by moving the cursor to the upper left position of the rectangle and pressing the Return key and then doing the same for the lower right corner of the rectangle. The corners are inclusive; that is, the rows and columns that contain the corners become the outermost edges included in the shape table. A portion of the rectangle selection process is shown in photo 3. After you select the desired rectangle, the program will form the shape table. The time this takes (typically 15 to 30 seconds) depends on the size of the shape. The completed shape table is displayed on the screen in either decimal or hexadecimal form, de-

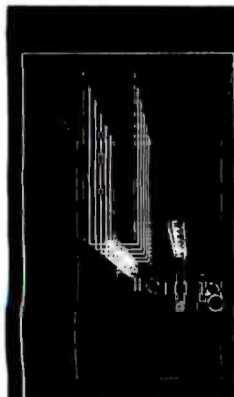

GRAPHIC SOFTWARE-

A self-teaching guide of 61 BASIC programs that will show you how to write your own 2D and 3D graphics software: create 2D and 3D shapes, translate, rotate, scale, stretch, clip, remove hidden lines, shade, perspective views, surface intersections, animation, applications to science, business, engineering. Named 'The best book available for micro graphics' by Creative Computing. Special IBMpc version also covers separating text from graphics, hardware requirements and more.

- Book 'Graphic Software for Micros'-\$21.95
- IBMpc Graphics-\$24
- Apple Disk \$19.95
- IBMpc Disk \$21.95

SOFTKITS™: Our publications are called SOFTKITS. They contain ready-to-run programs written in BASIC. Listed alongside theory, equations and sample problems. This format allows you to learn how such programs are written, modify and combine them for custom applications, or use them as-is. Disks (Apple and IBMpc) contain the same programs in Applesoft BASIC or IBMpc BASICA..

DATA PLOTTING SOFTWARE-

18 programs to process and display business and scientific data: Pie, bar, stock market charts, histograms, 3D views of surfaces, log plots, semi-log plots, curve fitting, regression, statistical analysis. Data management programs create disk data files, recall, update, list, refile. Special features- text over graphics, auto-scaling, auto-replot when data changes. All programs in BASIC, modular, menu driven, fully explained. Use as-is or modify and combine for custom applications.

- Book 'Data Plotting Software for Micros'-\$28.50
- Apple Disk \$19.95
- IBMpc Disk \$19.95

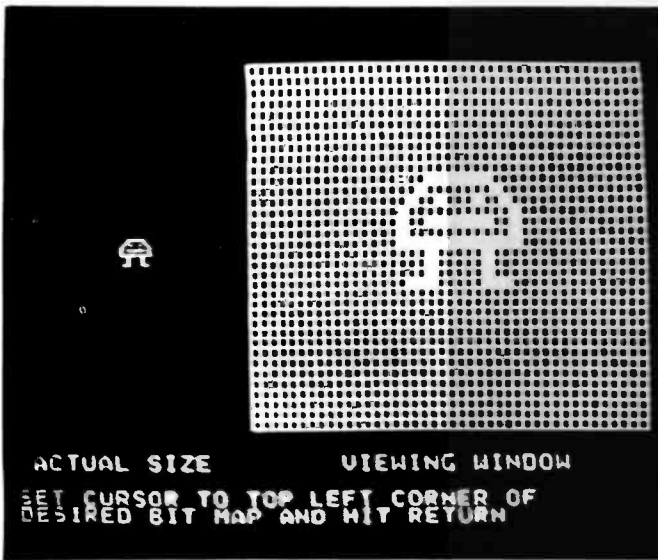

Photo 3: A view of the first step in forming a shape table. The desired shape is selected by defining a rectangle enclosing the shape. Here, the user has positioned the cursor to the correct position to define the upper left corner of the rectangle.

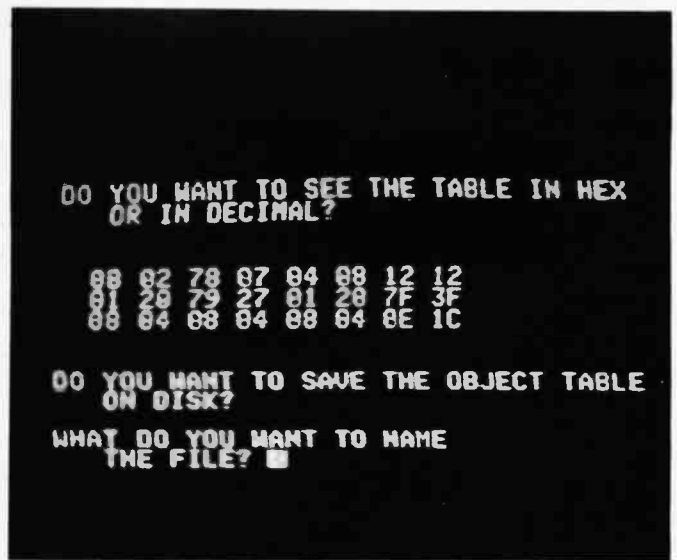

Photo 4: A view of the screen after the shape-editor program has formed the shape table for the shape shown in photo 3.

pending on how you answer a prompt. The program will then save this object-file shape table on disk as a standard binary file if you so desire. You are then asked whether to return to the screen-edit mode or end the program. Photo 4 shows the final shape table formed from the sample shape used in photo 3.

The Save and Get commands let you store on disk and later retrieve any picture drawn in the screen-edit mode. The Save command prompts you for a file name and then saves to disk a representation of the shape drawn on the grid. The Get command can then be used to retrieve and display the picture as long as the saved file remains on disk. Because the Get command erases any draw-

ing previously on the screen, you are first asked to confirm that a file is to be loaded. Once the picture is retrieved, it can be modified or assembled into a shape table just as if the picture had been entered using the keyboard commands.

The Help command (executed by pressing the H or ? key) returns you from the screen-edit mode to the menu shown at the beginning of the program for a quick command-letter check. Pressing the space bar returns you to screen-edit mode with the contents of the screen unaltered. The Quit command ends the program. Because any drawing on the screen is lost once the program is ended, you are asked to confirm the Quit directive.

Summing Up

Using the techniques and programs described in this article, you can implement professional-looking animation on the Apple without having to work around the limitations of the standard Apple shape subroutine. Although I wrote my shape subroutine with animation in mind, the subroutine is useful in any graphics applications where detailed shapes must be drawn. Using the graphics editor as a development tool, virtually any shape can be easily displayed on the hi-res screen. ■

Richard T. Simoni Jr. (29 Farnham Park Dr., Houston, TX 77024) is currently enrolled as a senior electrical engineering/computer science/math science major at Rice University in Houston, Texas.

MAIL LIST SOFTWARE-

a series of ready-to-use mail list programs arranged in a tutorial sequence that show how to write mail list software: Create random access data files, store on disk, recall, update, sort by zip code, sort in alphabetical order, list, print mail labels. Programs progress step-by-step from elementary file handling concepts and build to ready-to-use mail list software. Perfect for small businesses who want to customize their own software. Programs listed in the book in IBMpc BASICA; disks available for Apple and IBMpc.

- Book 'Mail List Software for Micros'-\$32.50
- Apple Disk \$19.95 IBMpc Disk \$19.95

STRUCTURAL SOFTWARE-

11 programs combining structural analysis with graphics: Create a 3D mesh interactively, rotate in 3 dimensions, store on disk. Then recall, do linear and non-linear 3D truss analysis, linear 3D frame analysis using the 'direct stiffness' method. Also do combined stress analysis, calculate geometric properties of beam cross-sections. Truss programs graphically display deformed shape of structure. All programs in BASIC fully documented with theory, equations, sample problems.

- Book 'Structural Analysis Software for Micros'-\$42.50
- Apple Disk \$42.50 IBMpc Disk \$42.50

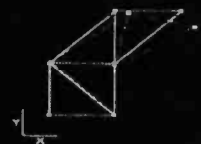

KERN
PUBLICATIONS

TO ORDER: Send check on US bank, money order in US funds, VISA/MASTERCARD no with exp date to KERN PUBLICATIONS, PO Box 1029-BJ, Duxbury, MA 02332. Ad \$2 per book 4th cl mail in US and Canada; \$4 1st cl or UPS in US; \$4.50 1st cl Canada; \$12 air Europe and Central America; \$18 elsewhere. For faster delivery call (617)934-0445.

computer mail order

PRINTERS

EPSON
 MX80, MX80 FT, MX100 CALL
 RX80 CALL
 FX80, FX100 CALL

OKIDATA

82, 83, 84 CALL
 92, 93 CALL

STAR

Gemini 10K \$299.00
 Gemini 15 \$478.00
 Serial Board \$75.00

SMITH CORONA

TP-1 \$499.00
 TP-2 CALL
 Tractor Feed \$129.00

C.I.TOH

Gorilla \$209.00
 Prowriter 8510P \$379.00
 Prowriter 1550P \$689.00
 Starwriter F10-40P \$1149.00
 Printmaster F10-55P \$1599.00
 Tractor Feed \$109.00

DAISYWRITER

2000 Letter Quality \$1149.00
 2500 "NEW" CALL
 Tractor Feed \$109.00

DIABLO

620 \$949.00
 630 \$1769.00

IOS

Call for ALL Configurations on
 IOS PRISM PRINTERS

NEC

8023 \$399.00
 7710/7730 \$2149.00
 3510/3530 \$1549.00

CABLES & CONNECTIONS

PRINTER CABLES

Atari to Parallel \$29.00
 Atari to Serial \$29.00
 Apple to Parallel \$69.00
 Apple to Parallel/Graphics \$99.00
 Apple to Serial \$89.00
 IBM to Parallel \$35.00
 IBM to Serial \$29.00
 Parallel to Parallel \$29.00
 Serial to Serial \$29.00
 Grappier Plus \$129.00
 PKASO \$139.00
 Atari to Modem Cable \$29.00
 CBM 84 to IEEE Board \$79.00
 Apple 80 Column Card \$159.00

HEWLETT PACKARD



HP 41CV... \$209.00
 HP 75... \$749.00
 HP 41C \$146.00
 HP 10C \$52.00
 HP 11C \$69.00
 HP 12C \$92.00
 HP 15C \$92.00
 HP 16C \$92.00
 For HP41/41CV
 HPIL Module \$99.00
 HPIL Cassette or Printer \$359.00
 Card Reader \$144.00
 Extended Functions Module \$64.00
 Time Module \$64.00

EAGLE

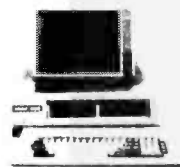

EAGLE

11E-1 \$1369.00
 11E-2 \$1649.00
 11E-3 \$2399.00
 11E-4 \$3199.00

PC-E \$1579.00
 PC-1 \$2399.00
 PC-2 \$2799.00
 PC-XL \$3599.00

1620 \$3599.00
 1630 \$5499.00
 1640 \$6499.00

MONITORS

AMDEK

300G \$149.00
 300A \$159.00
 310A \$169.00
 Color I \$279.00
 Color I plus \$299.00
 Color II \$399.00
 Color III \$349.00
 Color IV \$999.00

USI

Pi 1, 9 G \$99.00
 Pi 2, 12 G \$119.00
 Pi 3, 12 A \$159.00
 Pi 4, 9 A \$139.00
 1400 Color \$299.00

ZENITH

ZVM 121 \$95.00
 ZT1 Terminal \$369.00

BMC

12" Green \$85.00
 9191 13" Color \$299.00

TAXAN

12 N Green \$129.00
 12 A Amber \$139.00

PANASONIC

TR 120 Hi-res. Green \$159.00
 CT 160 Dual Mode Color \$299.00

NEC

JB 1260 \$119.00
 JB 1201 \$149.00
 JC 1212 \$299.00
 JC 12-202 \$299.00
 JC 1203 \$549.00

GORILLA

12" Green \$89.00

TIMEX SINCLAIR 1000

\$39⁹⁵



16K Memory \$44.95
 2040 Printer \$99.95
 Vu Calc \$17.95
 Check Book Manager \$13.95
 Organizer \$14.95
 Budgeter \$13.95
 Stock Option \$14.95
 Loan & Mortgage Amortizer \$12.95
 Min/Max Printer \$109.00

IBM

NEC3550 PRINTER... \$1799

PERCOM/TANOOM DRIVE

5 1/4" 320K Floppy \$279.00
 10 Meg Hard \$1495.00

AMDEK

310A Amber Monitor \$169.00
 DXY Plotter \$599.00
 Color II \$399.00

ABT

Conibo Plus CALL
 Mega Plus CALL
 Mega Pack CALL
 I/O Plus CALL

PROFESSIONAL SOFTWARE

PC Plus Word Processing \$319.00

MICRO PRO

Word Star/Mail Merge \$319.00
 InfoStar \$299.00
 Spell Star \$159.00
 CallStar \$159.00

MICROSTUF

Crosstalk \$139.00

MICROSOFT

Multiplan \$199.00

ABHNTON-TATE

D-Base II \$449.00

IUS

EasyWriter II \$209.00
 EasySpeller \$129.00
 EasyFiler \$129.00

CONTINENTAL SOFTWARE

1st Class Mail/Form Letter \$89.00
 The Home Accountant Plus \$109.00

BYNAPBE

File Manager \$119.00

PFB

APPLE IBM
 File \$89.00 \$99.00
 Report \$89.00 \$89.00
 Graph \$89.00 \$99.00
 Write n/a \$99.00

VIBICORP

FOR APPLE, IBM & FRANKLIN

Vidindex \$189.00
 Vidfile \$189.00
 Visiplot \$159.00
 Visiterm \$89.00
 Visitrend/Plot \$229.00
 ValSchedule \$229.00
 Desktop Plan \$189.00
 Visacalc (Apple, CBM, IBM) \$179.00
 Visicop prices for IBM may vary slightly.

SHARP

**PC-1500
POCKET COMPUTER
\$169.**

PC1250... \$89.00

CE-150 Printer, Plotter & Cassette
 Interface for 1500 \$172.00
 CE 125 Printer/Micro Cassette
 For 1250 \$129.00
 CE 152 Cassette Recorder \$82.00
 CE 155 8K Ram \$94.00
 CE 158 8K Ram Battery \$129.00

SANYO



MBC-555 \$795.00
 MBC-1000 \$1599.00
 MBC-160 Drive \$539.00
 PR5500 Letter Quality Printer \$899.00

MODEMS

HAYES

Smart \$219.00
 Smart 1200 (1200 Baud) \$519.00
 Chronograph \$199.00
 Micromodem 100 \$309.00
 Micromodem II \$279.00
 Micromodem II (with term) \$299.00
 Smart Com II \$99.00
 Smart 1200B \$489.00

NOVATION

J-Cat \$119.00
 Cat \$144.00
 D-Cat \$159.00
 103 Smart Cat \$189.00
 Apple Cat II \$279.00
 103 212 Smart Cat \$439.00
 212 Apple Cat II \$609.00
 Apple Cat II 212 Upgrade \$309.00

ANCHOR

Mark I (RS-232) \$79.00
 Mark II (Atari) \$79.00
 Mark III (T 1 99) \$109.00
 Mark IV (CBM-PET) \$125.00
 Mark V (Osborne) \$95.00
 Mark VI (IBM-PC) \$179.00
 Mark VII (Auto Ans. Auto Dial) \$99.00
 Mark VIII (1200 Baud) \$269.00
 TRS-80 Color Computer \$99.00
 9 Volt Power Supply \$9.00

READY FORMS

1" or 2" Address Labels (Tract. Feed) \$9.95
 15" Report Paper (Tract. Feed) \$24.95
 8 1/2" Bink Wh Paper (Tract. Feed) \$19.95
 8 1/2" Bink Env (Tract. Feed) \$14.95

TeleVideo



TERMINALS

910 \$559.00
 912 \$689.00
 920 \$739.00
 925 \$719.00
 950 \$929.00
 970 CALL

COMPUTERS

800A \$1259.00
 802 \$2199.00
 803 \$1949.00
 802H \$4695.00
 808/20 \$4949.00
 816/40 \$8999.00
 1602 \$3399.00
 1603 CALL

FRANKLIN



Call for Price & Information on
 Franklin 1000, 1100, 1200 and
 Other NEW Franklin Hardware &
 Software & Special System Pricing

MICRO-SCI

Apple & Franklin

A2 \$249.00
 A40 \$349.00
 A70 \$459.00
 C2 Controller \$79.00
 C47 Controller \$89.00

RANA

Elite I (Apple/Franklin) \$279.00
 Elite II (Apple/Franklin) CALL
 Elite III (Apple/Franklin) CALL
 1000 (Atari) CALL

MEMORY

MPC

Bubdisk (128K Non Volatile) \$649.00

AXLON

Apple/Franklin 128K Ram \$259.00
 Apple/Franklin Ram Disk \$279.00

INFDCOM

DeadlineAP... IBM, AT, AC-64 \$35.00
 Star Cross \$29.00
 Zork I, II or III \$29.00

BRODERBUND

Apple Panic \$23.00
 David's Magic \$27.00
 Star Blazer \$25.00
 Arcade Machine \$34.00
 Choplitter \$27.00
 Serpentine \$27.00

BIRIUB

Bandits \$28.00
 Bear Run \$24.00
 Free Fall \$24.00
 Sneakers \$24.00
 Snake Byte \$24.00
 Fast Eddie (Atari) \$21.00
 Turnoff (Atari) \$21.00
 Ducky Duck (VIC) \$21.00

AMDEK DISK DRIVES

Amdisk I, 3" Mini Disk for
 Apple II & IIE \$229.00

FLOPPY DISKS

maxell

MD-1 (Box of 10) \$32.00
 MD-2 (Box of 10) \$44.00
 FD-1 (B) \$40.00
 FD-2 (B DD) \$50.00

ELEPHANT

5 1/4" 55 SD \$18.95
 5 1/4" 55 DD \$24.95
 5 1/4" DS DD \$29.95

VERBATUM

5 1/4" 55 DD \$26.00
 5 1/4" DS DD \$36.00

HEAD

Disk Head Cleaner \$14.95

Circle 93 on inquiry card.

computer mail order west



800-648-3311

In NV call (702)588-5654, Dept. 801, P.O. Box 6689, Stateline, NV 89445

No risk, no deposit on C.O.D. orders. Pre-paid orders receive free shipping within the UPS Continental United States with no waiting period for credit checks or money orders. Add 3% (minimum \$3.00) shipping and handling on all C.O.D. and credit card orders. Larger shipments may require additional charges. NV and PA residents add sales tax. All items subject to availability and price change. NOTE: We stock manufacturer's and third party software most all computers on the market. Call today for our new catalog.

computer mail order

commodore

ATARI™ HOME COMPUTERS

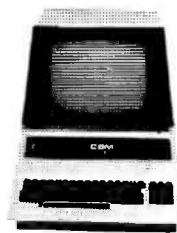

CBM 8032

\$ 599⁰⁰



**EXECUTIVE 64
PORTABLE**

CBM 64
\$ 239⁰⁰

VIC 20
\$ 99⁰⁰

- 1520 Color Printer/Plotter \$169.00
- 1525 80 Column Printer \$219.00
- 1526 80 Col. Printer \$319.00
- 1530 Datasheet \$69.00
- 1541 Single Disk Drive \$249.00
- 1600 VIC Modem \$59.00
- 1650 AD/AA Modem \$89.00
- 1701 14" Color Monitor \$249.00

PROFESSIONAL SOFTWARE
Word Pro 64 \$69.95

CARDCO
Light Pen \$32.00
Cassette Interface \$29.00
Parallel Printer Interface \$69.00
3 Slot Expans. Interface (20) \$32.00
6 Slot Expans. Interface (20) \$79.00

PROFESSIONAL SOFTWARE
Word Pro 2 Plus \$159.00
Word Pro 3 Plus \$199.00
Word Pro 4 Plus \$299.00
Word Pro 5 Plus \$299.00
InfoPro \$199.00
Administrator \$379.00
Power \$79.00

- Pei 64 \$569.00
- Pei 4032 \$599.00
- CBM 8032 \$599.00
- Super Pet \$999.00
- B128-80 \$769.00
- BX256-80 \$969.00
- 2031 \$299.00
- 4040 \$699.00
- 8050 \$949.00
- 8250 \$1199.00
- 9060 \$1999.00
- 9090 \$2199.00
- 4023 \$379.00
- 6400 \$1399.00
- 64K Upgrade Kit \$269.00
- Spell Master \$149.00
- Z-Ram \$549.00
- Silicon Office \$749.00
- The Manager \$209.00
- Soft Rom \$129.00
- Jinsam CALL
- ADA 1450 I/Serial \$59.00
- ADA 1600 I/Parallel \$89.00



- 600XL (16K Ram) \$149.
- 800XL (64K Ram) NEW
- 1200XL (64K Ram) NEW
- 1400XL (64K Ram) NEW
- 1450XL (64K Ram) NEW

- 1010 Program Recorder \$74.00
- 1020 40 Col. Printer/Plotter \$249.00
- 1025 80 Col. Printer \$449.00
- 1027 Letter Quality Printer \$299.00
- 1050 Disk Drive \$379.00
- 850 Interface \$169.00
- 1030 Direct Connect Modem CALL
- CX30 Paddles \$12.00
- CX40 Joystick \$8.00
- CX42 Remote Joystick CALL
- CX77 Touch Tablet \$89.00
- CX80 Trak Ball \$49.00
- CX85 Keypad \$105.00
- CX148 Home Manager \$89.00
- CX488 Communicator II \$229.00
- KX709B Atari Accountant \$209.00
- KX7101 Entertainer \$69.00
- KX7102 Arcade Champ \$75.00

SYNAPSE

- File Manager 800 plus \$69.00
- Chicken (ROM) \$34.00
- Picnic Paranoia (ROM) \$34.00
- Claim Jumper (ROM) \$34.00
- Silme (ROM) \$34.00
- Shemus (ROM) \$34.00
- Protector (ROM) \$34.00
- Dodge Racer (C/D) \$26.00
- Nautilus (C/D) \$26.00
- Shadow World (C/D) \$26.00
- Survivor (C/D) \$26.00
- Dreals (C/D) \$26.00
- Necromancer (C/D) \$26.00
- Phero's Curse (C/D) \$26.00
- Fort Apocalypse (C/D) \$26.00
- Assembler \$30.00

L.J.K.

- Letter Perfect 40/80 Col. Disk \$106.00
- Letter Perfect 40 Col. ROM \$179.00
- Letter Perfect 80 Col. ROM \$179.00
- Oeta Perfect 40/80 Col. Disk \$99.00
- Mail Merge \$21.95

SPINNAKER

- Snooper Troops #1 \$34.00
- Snooper Troops #2 \$34.00
- Face Maker \$24.00
- Story Machine \$24.00
- Delta Drawing \$45.00
- Rhymes and Riddles \$21.00
- Kindercomp \$21.00

ROKLAN

- Wizard of War (ROM) \$34.00
- Deluxe Invader (ROM) \$29.00
- Gorf (ROM) \$34.00

DATASOFT

- Pacific Coast Highway \$17.00
- Canyon Climber \$17.00
- Tumble Bugs \$19.00
- Shooting Arcade \$19.00
- Clowns and Balloons \$17.00
- Graphic Master \$24.00
- Graphic Generator \$13.00
- Micro Painter \$24.00
- Teal Wizard \$34.00
- Spell Wizard \$34.00
- Bishop's Square \$25.00
- Sands of Egypt \$19.00
- Moon Shuttle \$25.00
- Basic Compiler \$54.00
- Tele-talk \$34.00

CBS

- Krazy Shoot Out \$29.00
- Krazy Killers \$29.00
- Krazy Antics \$29.00
- Krazy Patrol \$29.00
- Stuck Stand \$3.99

ALIEN

- Atari Voice Box \$119.00
- Apple Voice Box \$149.00

MEMORY

- Aston 32K Ram \$65.00
- Aston 48K Ram \$109.00
- Aston 128K Ram \$299.00
- Intec 32K Board \$74.00
- Intec 64K Board \$99.00
- Intec 64K Board (400 only) \$149.00

JOYSTICKS

- Wico Joystick \$24.95
- Famous Red Ball \$26.95
- Apple Trackball \$59.00
- Atari/VIC Trackball \$55.00
- Apple Adaptor \$16.00
- Krali Apple Joystick \$44.00



DISK DRIVES FOR ATARI

- AT88-S1 \$369.00
- AT88-A1 \$299.00
- AT88-S2 \$569.00
- AT88-S1 PD \$419.00
- AT88-S2 PD \$669.00
- AT88-DDA \$139.00
- AT44-S1 \$579.00
- AT44-S2 \$969.00
- Texas Instruments Drive \$369.00

C.M.O. TOP 100

- APPLE/FRANKLIN**
- Choplifter \$27.00
 - Beer Run \$24.00
 - PFS File \$89.00
 - Visicalc \$179.00
 - Home Accountant \$45.00
 - Arcade Machine \$34.00
 - Bandits \$28.00
 - Visitile \$189.00
 - Apple Panic \$24.00
 - Deadline \$35.00
 - Free Fall \$24.00
 - PFS Report \$89.00
 - Zork III \$26.00
 - Frogger \$31.00
 - Lal Pas \$31.00
 - Gulchic Attack \$24.00
 - Snooper Troops #1 \$24.00
 - Kindercomp \$21.00
 - Wavy Navy \$21.00
 - Visionist \$89.00
 - Mission Asteroid \$116.00
 - Lunar Leaper \$27.00
 - Facemask \$28.00
 - Crossfire \$27.00
 - Pool 1.5 \$27.00

- CBM 64**
- 1. Word Pro 64 \$69.95
 - 2. Kickman (20/64) \$14.95
 - 3. Gorf (20/64) \$14.95
 - 4. Microspec Data Base 64 \$69.00
 - 5. Logo 64 \$39.00
 - 6. Microspec Gen. Ledger 64 \$79.00
 - 7. Zork \$24.95
 - 8. Frogger (64) \$23.00
 - 9. Quick Brown Fox (20/64) \$49.00
 - 10. Shamus \$29.00
 - 11. Deadline \$35.00
 - 12. Assembler 64 \$14.95
 - 13. Zork I \$19.00
 - 14. Radar Rai Race (20/64) \$12.00
 - 15. Protector \$32.00
 - 16. Starcross \$29.00
 - 17. Easy Mail 64 \$14.95
 - 18. Grave Robber \$11.00
 - 19. Wall Street \$19.00
 - 20. Trash Man \$32.00
 - 21. HES Writer \$35.00
 - 22. HES Mon \$29.00
 - 23. Road Toad \$24.00
 - 24. Easy Script \$79.00
 - 25. Gridrunner \$29.00

- ATARI**
- 1. Donkey Kong \$39.00
 - 2. Zaxxon \$29.00
 - 3. E.T. Phone Home \$39.00
 - 4. Miner 2049er \$35.00
 - 5. Dig Dug \$33.00
 - 6. Preppie \$24.00
 - 7. Donkey Kong Jr. \$39.00
 - 8. Canyon Climber \$17.00
 - 9. Snooper Troops #2 \$34.00
 - 10. Teal Wizard \$34.00
 - 11. Picnic Paranoia \$34.00
 - 12. Eastern Front \$39.00
 - 13. Shamus \$34.00
 - 14. Letter Perfect \$109.00
 - 15. File Manager 800 \$69.00
 - 16. Choplifter \$27.00
 - 17. Astro Chase \$25.00
 - 18. Krazy Shoot Out \$29.00
 - 19. Pac Man \$33.00
 - 20. Balla Buggies \$25.00
 - 21. Crush, Crumble & Chomp \$24.00
 - 22. Hell Fire Warrior \$19.00
 - 23. Zork II \$29.00
 - 24. Visicalc \$159.00
 - 25. Atari Writer \$79.00

- 26. Three Little Pigs \$25.00
- 27. Upper Reaches of Apshei \$16.00
- 28. Starbowl Football \$24.95
- 29. Oribis \$26.00
- 30. Protector \$34.00
- 31. Frogger \$31.00
- 32. Jawbreaker \$27.00
- 33. Wizard of War \$34.00
- 34. Kindercomp \$21.00
- 35. Moon Shuttle \$25.00
- 36. 747 Simulator \$18.50
- 37. Temple of Apshei \$29.00
- 38. Spell Wizard \$34.00
- 39. Nautilus \$26.00
- 40. Krazy Antics \$29.00
- 41. Soft Porn \$27.00
- 42. Qix \$33.00
- 43. Wizard & Princess \$29.00
- 44. Centipede \$33.00
- 45. Strip Poker \$24.95
- 46. Juggles House \$23.00
- 47. Jumpmen \$24.00
- 48. Silme \$26.00
- 49. Gorf \$32.00
- 50. Juggles Rainbow \$23.00

computer mail order east

Circle 93 on inquiry card.

800-233-8950



PA call (717)327-9575, Dept. 801, 477 E. 3rd St., Williamsport, PA 17701

INTERNATIONAL ORDERS: All shipments outside the Continental United States must be pre-paid by certified check only. Include 3% (minimum .00) shipping and handling. EDUCATIONAL DISCOUNTS: Additional discounts are available from both Computer Mail Order locations to qualified educational institutions. APO & FPO: Add minimum \$5.00 shipping and handling.

The Debate Goes On . . .

A discussion of the future of microcomputer languages

by Jerry Pournelle

I've written several large computer programs. The two largest, an accounting package and my minimum database do-all program, were originally written in BASIC. Another large program, my interstellar trader game, was written in Pascal. Recently I've had to make extensive revisions in all three—with interesting results.

First, I find it impossible to work with BASIC programs. My accounting package, although originally in BASIC, was long ago translated to CBASIC and from that to CB-80 (also called Compiled CBASIC). The translations make it possible to maintain the programs. If that hadn't been done, I wouldn't even try.

Example: my accounting program doesn't do depreciation, because almost all my accounting is done to satisfy the IRS, and the IRS wants depreciation handled in a rather special way. When I first began using microcomputers to keep my books, I wrote what I thought was a simple BASIC program to keep track of depreciation. It didn't have to do

much: simply list the item, when it was bought, the useful life, purchase price, amount claimed this year, and cumulative amount claimed over the life of the item. Each year I add new items at the end of the list, then run the program to figure and list out depreciated items.

The program has some checking to do, of course; the last year's claimed amount can't make the cumulative amount claimed be larger than the purchase price. Also, if the item was purchased *this* year, you can't claim a full year's depreciation, and have to prorate it by the number of months you've used the equipment. Even so, it's a simple program.

It's simple, but this year it took me about as long to update that simple-minded little BASIC program as it did to add major new features to the accounting package. When I get a chance, I'm going to scrap my depreciation program and write it over, probably in CB-80 because it has to handle files, and I've still got some problems doing file handling with CP/M Pascal.

What I'm not going to do is put up with normal BASIC programs, with their line numbers, cramped printout format, and the primitive text-editing capabilities.

With CB-80 it's possible to write structured programs. Moreover, the compiler can be used to catch a lot of bugs. Example: my minimum database has a procedure to check the size of any entry. This is useful, because entries that are too long can't be printed properly (especially if they're to be printed on a mailing label). The original program got its input by calling a subroutine that both input the data and checked the input length.

Alas, that's silly. If you forget to specify the input length before calling the input subroutine, then the input length is checked against what the program was *last* told the input length should be; and that can cause really boffo problems. I know, because I did forget, not once but several times.

The remedy was simple: use a *function* to get input and check

Four Answers To Your S-100, Multi-User Problems.

Intercontinental Micro Systems makes everything you need for S-100 bus multi-user systems, networks or single user systems.

At a price that won't break your budget.

Quite simply, our single board computers, slaves, 256K memories and personality boards let you build a system *now*, not later. The hardware works, the software works,

and the prices are what you'd expect from a company that uses the most advanced design, software and production techniques to keep costs down.

What you won't expect is the almost awesome sophistication of Intercontinental Micro System's products.

So stop messing around with multiple sourc-

ing, hardware integration problems and software nightmares. Come to Intercontinental Micro and get it all — price, performance and delivery.

Read the specs, then call, write or circle the bingo number below. We'd be glad to send more information and help solve your S-100, multi-user system problems.

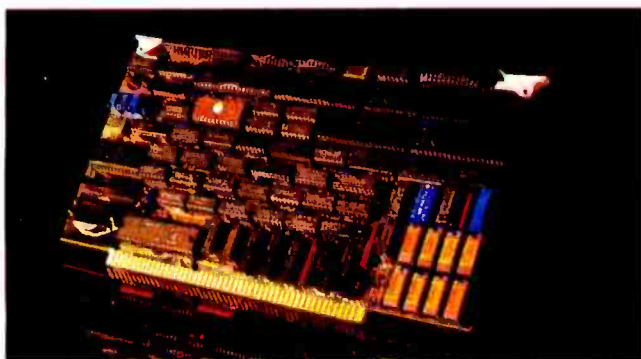

2 CPX-MX SLAVES.

□ IEEE 696.1/D2 S-100 compliance. □ Compatible with CPZ-48000 SBCP, any Z-80A based CPU with extended address capability or 16 bit based CPUs complying with IEEE 696.1/D2 bus specification. □ Z-80B™ 6MHz (CPS-6X) or Z80A 4MHz (CPS-4X) operation. □ Two synchronous (CPS-MS) or asynchronous (CPS-MA) serial I/O ports. □ TurboDOS™ & CP/NET™ compatible. □ Master confiscation of slave memory for diagnostic purposes. □ Two parallel I/O ports: eight data bits + 2 handshake lines per port. □ 64 Kbytes of onboard dynamic RAM. □ Master/slave memory-to-memory transfers under DMA control @ 571 Kbyte/sec transfer rate when used with CPZ-48000 SBCP. □ Software selectable baud rates. □ Usable as an intelligent I/O processor in single user system.

1 CPZ-48000 SINGLE BOARD COMPUTER.

□ IEEE 696.1/D2 S-100 compliance. □ Z80A™ 4MHz Operation. □ Floppy disk controller (FDC). Single or double sided. Single or double density. 8" or 5¼". □ Two synchronous or asynchronous serial I/O channels (SIO). □ Two parallel I/O channels (PIO). □ Four channel DMA controller. □ 64K on board RAM. □ Memory management unit (MMU). Addresses up to 16 megabytes of system memory. □ Eight Vectored priority interrupts. □ Provisions for 2K or 4K onboard EPROM. □ Software selectable baud rates. □ IBM Bisync, HDLC, SDLC and other protocols. □ CP/M,™ MP/M,™ and TurboDOS™ operating systems available. □ Turbo-Disk™ implementation included.

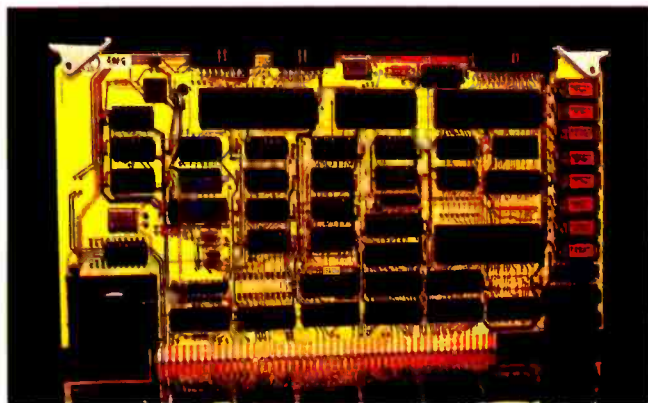

3 256KMB-100 256K MEMORY.

□ IEEE S-100 bus, spec 696.1/D2 compliance. The 256KMB-100 is compatible with most IEEE S-100 board products now on the market. □ Linear addressable to 2 megabytes. □ 225 nano-second access time, maximum, 160 nano-seconds, typical. □ 295 nano-second read-write time, minimum. □ Bank selectable 16K increments. □ I/O port address bank selection. □ Configures for phantom deselection. □ Parity error detection, visual and/or interrupts. □ Bank selection compatible with CROMIX,™ CP/M2.2,™ MP/M,™ Alpha Micro, and other major systems.

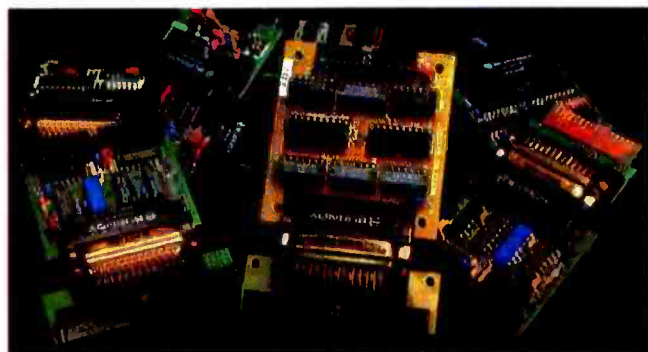

4 PERSONALITY BOARDS.

□ Centronics printer. □ 8 inch floppy disk. □ 5¼ inch floppy disk. □ RS232 serial communications. □ Synchronous/asynchronous modem. □ Priam smart/smart E hard disk. □ Long distance serial communication (2000 ft @ 9600 baud). □ Shugart Associates Systems Interface (SASI). □ Clock/calendar. □ Konan David, Jr.™ hard disk. □ Archive tape drive.

Circle 212 on inquiry card.

1733 South Douglass Road, Ste. E
Anaheim, California 92806
(714) 978-9758
Telex: 678401-TAB-IRIN



Z80A & Z80B are trademarks of ZILOG Corp. • CP/M, MP/M & CP/NET are trademarks of Digital Research Corp. • TurboDOS is a trademark of Software 2000 Inc. CROMIX is a trademark of CROMEMCO Corp. • DAVID JR. is a trademark of KONAN Corp.

Give us a call and it's on its way.

Our inventory is so huge, we've probably got just what you want in stock. We'll ship it out right now. At the right price.

DISKETTES

SCOTCH 3M

S S D DEN 40 TRK.10.16 SECTOR.....	23.50
D S D DEN 40 TRK.10.16 SECTOR.....	36.50

VERBATIM DATALIFE

MD 525-01. 10. 16.....	26.50
MD 550-01. 10. 16.....	44.50

DISKETTE STORAGE

5 1/4" PLASTIC LIBRARY CASE.....	2.50
FLIP & FILE (50 Disk Capacity).....	19.95
DISK BANK 5 1/4".....	5.95

PRINTERS

RIBBONS FOR MX-80.....	8.95
RIBBONS FOR MX-100.....	19.95
C-ITOH F-10 40 CPS PARLL or SER.....	1250.00
C-ITOH F-10 55 CPS PARLL or SER.....	1639.00
C-ITOH PROWRITER PARALLEL.....	410.00
EPSON MX-80 W/GRAFTRAX PLUS.....	SCALL
NEW! EPSON RX-80.....	SCALL
NEW! EPSON FX-80.....	SCALL
EPSON MX-100 W/GRAFTRAX PLUS.....	SCALL
EPSON GRAFTRAX PLUS.....	60.00
BMC PB101 PAR.....	730.00
NEC 8023A.....	425.00

APPLE HARDWARE

PREMIUM PAK.....	455.00
MICROSOFT Z-80 SOFTCARD.....	249.00
MICROSOFT RAMCARD.....	79.00
VIDEX ULTRATERM.....	SCALL
VIDEX 80x24 VIDEO CARD.....	260.00
T/G JOYSTICK.....	44.95
T/G PADDLER.....	29.95
KRAFT JOYSTICK.....	48.00
VERSA E-Z PORT.....	21.95
MICROBUFFER II 1/2 16K W/GRAPHICS.....	199.00
MICROBUFFER II 1/2 32K W/GRAPHICS.....	219.00
SUPERFAN II.....	62.00
SUPERFAN II W/ZENER.....	84.50
RANA ELITE I.....	318.00
GRAPPLER+.....	139.00
7710A ASYNCHRON. SER. INTERFACE.....	149.00

MONITORS

USI AMBER 12".....	160.00
BMC GREEN MONITOR.....	89.00
TAXAN 12" AMBER.....	125.00
NEC GREEN.....	159.00

MODEMS

NOVATION J-CAT.....	125.00
NOVATION SMARTCAT.....	209.00
NOVATION APPLE-CAT (300 Baud).....	310.00
NOVATION APPLE-CAT (1200 Baud).....	605.00
HAYES MICROMODEM II.....	289.00
MICROMODEM W/TERMINAL PKG.....	309.00
HAYES SMART MODEM (300 Baud).....	227.00
HAYES SMART MODEM (1200 Baud).....	540.00
SIGNALMAN MODEM W /RS-232C.....	85.00

IBM HARDWARE

SEATTLE 64K RAM +.....	355.00
OUADBOARD 64K.....	338.00
64K MEMORY UPGRADE.....	69.00
APPARAT COMBO BOARD.....	175.00

MICROSOFT 64K.....	278.00
MONTE CARLO MULTIFUNCTION w/64K.....	395.00
T/G JOYSTICK.....	47.95
HERCULES GRAPHICS CARD.....	546.00
KRAFT JOYSTICK.....	48.00

Davong Systems, Inc. Call for prices and stock.

IBM 16K RAM KITS.....15.75

Set of 9 NEC 4116 200ns. Guaranteed one year FOR IBM-PC. set of 9..... 15.75

ALPHA BYTE IBM MEMORY EXPANSION BOARDS

256K W /RS-232C.....	349.00
256K W /RS-232C & SUPERCALC 2.....	529.00
512K W /RS-232C.....	579.00
512K W /RS-232C & SUPERCALC 2.....	749.00

IBM DISK DRIVES

Alpha Byte's add-on drive kits for the IBM-PC — each kit includes installation instructions.

Tandon TM100-1 Single head 40 Trk.....	195.00
Tandon TM100-2 Double head 40 Trk.....	262.50
Tandon TM55-2 Half Height.....	262.50
Tandon 5 1/4", 100-3 Sgl head 80 Trk.....	250.00
Tandon 5 1/4", 100-4 Dbl head 80 Trk.....	369.00

ISOLATORS

6 SOCKET SWITCHED.....	34.95
------------------------	-------

IBM SOFTWARE

LOTUS 1.2.3.....	380.00
VDLKS WRITER V 1.2.....	145.00
EASYWRITER II.....	247.00
HOME ACCOUNTANT +.....	105.00
FIRST CLASS MAIL.....	85.00
DBASE II.....	419.00
THE WORD PLUS.....	117.00
T.I.M. III.....	379.00
JFORMAT.....	39.00
JETDRIVE-ODS 2.0.....	40.00
MOVE IT.....	109.00
VISICALC / 256K.....	189.00
VISITREND / VISIPILOT.....	235.00
VISIDEX.....	192.00
VISIFILE.....	249.00
VISISCHEDULE.....	229.00
VERSA WRITER GRAPHICS TABLETS.....	270.00
VERSAFORM.....	312.00
CONCURRENT CP/M* 86.....	315.50
CP/M 86 DIGITAL RESEARCH.....	60.00
GRAPHICS HARD COPY SYSTEM.....	19.50
PFS: FILE.....	97.50
PFS: GRAPH.....	97.50
PFS: REPORT.....	97.50

Call for additional IBM software prices

IBM GAME SOFTWARE

ZORK I, II, III.....	28.00
STARCROSS.....	28.00
DEADLINE.....	35.00
THE WARP FACTOR.....	31.16
APPLE PANIC.....	23.61
TEMPLE OF ASPHAL.....	34.95
FROGGER.....	27.26

If you don't see the software you want, call. Our software stock is constantly expanding.

APPLE SOFTWARE

PFS: GRAPH.....	89.95
PFS: (NEW) PERSONAL FILING SYSTEM.....	85.00
PFS: REPORT.....	79.00
Z-TERM PRO*.....	129.95
BANK STREET WRITER.....	55.50
APPLE MECHANIC.....	23.00
TIP DESK #1.....	15.95
LISA 2.5.....	59.95
SCREENWRITER II.....	99.00
DICTIONARY.....	79.00
THE HOME ACCOUNTANT.....	59.95

VISICORP

VISIDEX.....	189.00
VISITERM.....	79.00
VISICALC.....	189.00
VISIFILES.....	189.00
VISISCHEDULE.....	229.00

CP/M® SOFTWARE

We carry CP/M® software in all popular disk formats. Call for availability and price. Most software also available on IBM.

DBASE II.....	419.00
MAC.....	82.00
ZSID.....	92.00
PASCAL MT + W/SSP.....	429.00
PL/ 1-80.....	439.00
MULTIPLAN.....	199.00

MICROPRO

APPLE/IBM/8" CPM

SPELLSTAR.....	174.00
MAILMERGE.....	174.00
WORDSTAR.....	279.00
INFOSTAR.....	279.00

NEW PRODUCTS COMING! CALL.

APPLE & ATARI GAMES

ZAXXON.....	31.16
CHOPLIFTER.....	27.20
CRUSH, CRUMBLE AND CHOMP.....	24.95
TEMPLE OF ASPHAL.....	31.35
WIZARD AND PRINCESS.....	27.26
SOFT PORN ADVENTURE.....	23.36
ULYSSES & GOLDEN FLEECE.....	25.95
ULTIMA II.....	42.00
FROGGER.....	24.50
ZORK I, II, III.....	28.00
STARCROSS.....	28.00
DEADLINE.....	35.00
FLIGHT SIMULATOR.....	26.61
SARGON II.....	28.95
THE WARP FACTOR.....	31.16
WIZARDRY.....	37.95
CRISIS MOUNTAIN.....	26.32
GORGON.....	31.16
BANDITS.....	25.00
LUNAR LEEPER.....	23.36
TIME ZONE.....	77.96
CANNON BALL BLITZ.....	25.95
ROBOT WARS.....	32.95

MICROSOFT

APPLE/IBM/CPM

FORTRAN.....	150.00
BASIC COMPILER.....	299.00
COBOL.....	550.00

RAMCARD.....	79.00
TYPING TUTOR II.....	16.50
OLYMPIC DECATHALON.....	24.95
TASC APPLESOFT COMPILER.....	125.00
ALDS.....	95.00
MULTIPLAN.....	199.00

To order or for information call

From Chicago:
(312) 454-1236

From New York:
(212) 509-1923

In Los Angeles:
(213) 706-0333

From Dallas:
(214) 744-4251

By Modem:
(213) 991-1604

CALL OUR MODEM LINE FOR WEEKLY SPECIALS.

Alpha Byte

COMPUTER PRODUCTS

31304 VIA COLINAS
WESTLAKE VILLAGE, CA 91362

*For all your computer product needs, come visit us at our new California store.

Satisfaction Assurance — Your satisfaction is assured by our 30 day moneyback guarantee on all hardware products we sell. No refunds after 30 days. All manufacturers' warranties are honored by manufacturers. Defective software will be replaced free during the first 30 days, however, no refunds or exchanges on software. Proof of purchase required. All returns must be authorized in advance. How To Order — All orders must be paid prior to shipment. Order by phone or by mail. Use Visa, M/C, check or COD. COD limit \$300. Shipping charges. Visa, M/C orders = actual shipping costs. Prepaid orders add \$3 (under 25lbs.) or \$6 (over 25lbs.) COD's use prepaid rates and add \$4 surcharge. Foreign, FPO and APO orders add 15% of order total. Calif. orders add 6% sales tax. L.A. County add 6 1/2% sales tax. Prices quoted are subject to product availability and may change without notice.

CP/M is a reg. trademark of Digital Research. *Requires Z-80 Softcard. 1Reg trademark of Micro Pro International Corp. †Trademark of Practical Peripherals, Inc. **Trademark of Software Dimensions, Inc.

length. Define the function so that you *must* give it a maximum input length as a parameter when you call it. Now if you forget to do that, the compiler will complain.

When I did this, it came to me with blazing clarity that I'd hit on a major secret of good programming practice: let the compiler do much of the work for you. CB-80 is well designed to let you write structured code with good error checking.

However: it doesn't *force* you to write good code. You can still do things the wrong way if you want to. Pascal doesn't force you to write good code either, but it tries harder than CB-80. Marvin Minsky (co-founder of the MIT Artificial Intelligence Laboratory) once said that Pascal was a voluntarily worn strait-jacket. In some ways he's right: one uses Pascal precisely because it won't let you do certain things. This can be annoying when you're writing the program, but it's surely a blessing when, later on, you haul it out and try to remember what you did.

With that for background, let's speculate on the future of computer languages.

Viable Languages

I used to worry about conducting language discussions, because probably half my readers don't write programs. However, the mail indicates that even those who don't write programs find the subject interesting. It is, after all, a matter of some importance: what languages will prevail in the microcomputer field?

No one knows. I have some informed guesses, and I get a lot of feedback from both amateur and expert readers; but I've lost the operator's manual to my crystal ball, so my predictions aren't 100 percent reliable. For all that, the subject is too important to ignore, and every now and then it's valuable to review just where things are in the field.

Let's set a ground rule. It's obvious that microcomputers will continue to grow in capability even as their prices fall. The distinction between microcomputer and minicomputer is already blurred. In the next few years, memory will continue to drop

in price while system speeds increase; within two years, one will be able to buy the equivalent of a VAX—the top-of-the-line minicomputer from Digital Equipment Corporation—for \$6000 or so, what people now pay for a good microcomputer. This future "microcomputer" will run at 12 to 15 MHz and have a half-million to a million bytes of memory; in other words, the microcomputer will in effect have the power of machines that people now pay \$75,000 and up for.

What languages will programs for the new generation of "microcomputers" be written in?

The first thing to note is that "efficiency" of the language isn't very important. There's enough computing power and memory to make up. True, languages that are *really* slow, or waste great gobs of memory, aren't likely to become popular; but cheeseparing benchmark comparisons won't matter a lot.

Given that, let's look at the candidate languages.

DECADES OF SERVICE

Washington Computer Services

97 Spring Street

New York, New York 10012

TO ORDER: CALL OUR TOLL-FREE NUMBER: (800)221-5416

In N.Y. State and for technical information: (212) 226-2121

HOURS: 9:30 AM — 5:30 PM (EST) Monday-Friday

an affiliate of **WASHINGTON ELECTRIC COMPANY** est. 1912

CUSTOM COMPUTER ROOM WIRING SINCE 1960

TELEX: 12-5606 CABLE: WASHCOMP NYK

FULLY CONFIGURED BUSINESS SYSTEMS

The following are some examples of the fully assembled and tested business and scientific computer systems which we offer:



The Premier Multi-User Computer System
8000 SX, multi-processor, turbo DOS
CPM 2.2 FULL 2 YEAR WARRANTY!
5000 IS, S-100 desk top mainframe
8000 S up to 16 user
3270 Software Available
On-Site Service Contracts Available

CALL FOR CONFIGURATION

Where Do You Turn To Solve Your Computer Puzzle?



TURN TO US!

We'll show you the easiest way to put the pieces together.

Matched, Compatible, Proven—Use Someone Else's Engineering to Supplement Yours.

NEC APC

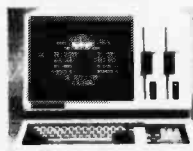

8086, 16 bit processor; Two 8" DSDD disk drives; 128K RAM (to 640K); green or RGB color screen.

PERFECT FOR:

- Word Processing
- CAD/CAM graphics (1024 x 1024 resolution)
- DataBase Management
- Accounting

• Chang Lab's Microplan • IBM emulations • CP/M-86, MSDOS, UCSD P.

NEC on N.Y.S. Contract #P-07220

ALSO PC-8800 Personal Computer

EPSON

NEW QX-10 Micro with VALDOCS software: \$2995.

68000 16 bit multi-user, S-100, UNIX v. 7

SCALL



8086 16 bit, 128K RAM, S-100, Gazelle



8 & 16 BIT BOARDS & SYSTEMS

SCION MicroAngelo Hi Res Graphics Systems

SCALL

Similar savings on SSM, DELTA, DYNABYTE, TELEVIDEO, DIGIAC, ADDS, DEC, DATA GEN., ATARI, TECHMAR, EPSON, ZENITH, MORROW, AND MANY OTHERS

SOFTWARE

Over 2000 business scientific, professional applications & educational packages are available. Call with your requirements for our advice or a quotation. We feature DBase II & Fox & Geller.

8" DISK DRIVE SALE

NOW!

8" SHUGART SAB01R \$385 8" SHUGART SA851R \$540 2 for \$1025
QUME DATATRACK 8 or MITSUBISHI \$550 2 for \$1050
Enclosure, power supply for 2 8" drives A & T \$350
MORROW DISCUS 20 + CP/M MICROSOFT BASIC, CONT. \$950
VISTA \$CALL

TERMINALS

TELETYPE	AMPEX	QUME
TELEVIDEO	ADDS	IBM 3101
LEAR SIEGLER	ANN ARBOR	DIGITAL EQUIP. CORP.
	VISUAL	HAZELTINE

PRINTERS

Teletype 40, 300 LPM-typewriter quality, RS-232 from Only \$3200 interface. This quality printer is available in many configurations including forms access, queued case, etc.

Teletype 43 from \$995		
ANADIX	DIABLO	MANNESMANN TALLY
CENTRONICS	EPSON	NEC AMERICA
C. ITOH	FACIT	QUME
DATA PRODUCTS	OKIDATA	TOSHIBA
DIGITAL EQUIP. CORP.	OLIVETTI	TELETYPE
INTERGRAL DATA SYS.	QANTEX	TEXAS INSTRUMENTS

PLEASE! Do not confuse us with mall order dealers. We are a full service distributor serving the data processing & installation needs of business & industry from micros to mainframes. System houses, educational institutions & governmental agencies given special consideration. Leasing available.

N. Y. State agencies, municipalities, and schools — call us for information on our O.G.S. term contracts on hardware & software.

DEALER and INTERNATIONAL INQUIRIES WELCOME

For fast delivery, send certified check, money order or call to arrange direct bank wire transfer. Personal or company checks require two to three weeks to clear. Prices subject to change without notice; call for latest prices. Prices include 3% cash discount. N.Y. residents add sales tax. Qantex is a trademark of North Atlantic Industries, Inc. CP/M™ is a trademark of Digital Research. All sales subject to our standard sale conditions (available on request). Call for shipping charges. Above prices do not include customization or installation. DBase II is a trademark of Ashton Tate. P.O.'s accepted upon our credit approval; call for prices and terms.

Expensive.



The new RCA APT expands your data communications

For business, professional and personal data communications, you'll find more user-friendly features and greater communications capabilities in the RCA APT than in other terminals selling for up to three times the price.

The new APT terminals are ideally suited to multi-data base time sharing and dedicated, direct computer-connected applications. They feature menu-controlled operation and a programmable "personality" to match specific communications requirements for your data bases.

A single keypress can dial a stored number, send the log-on sequence to the host computer, and return terminal control to the user. Password protection prevents unauthor-

ized access to designated numbers. APT can also be used as an auto-dialer for voice communications.

APT terminals list for \$399, in your choice of full stroke or membrane keyboard versions. Either style is also available with a display monitor for \$598 list. The data display monitor alone, VP3012D, \$229 list.

OEM and dealer pricing available.

APT VP3801. Flexible membrane keyboard version designed for travel and hostile environments.

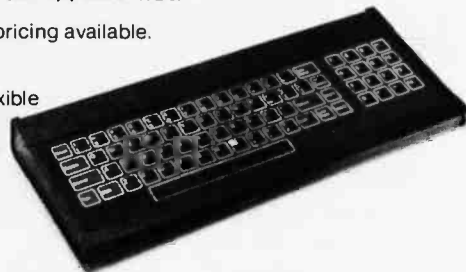

Expansive.



(All Purpose Terminal) capabilities for a lot less money.

Quite simply, matching features with price, there is no other professional quality terminal available today that can do as much at such low cost.

For more information, just clip the coupon at right. The new RCA APT. Expansive. Not expensive.

OTHER FEATURES

RS232C port for direct computer connections at data rates to 9600 baud, or for connecting high speed modems and other accessories. Parallel printer port for hard copy. Numeric keypad, can dial phone numbers not in terminal directory. Built-in speaker with adjustable volume control for audio monitoring of phone line. Smooth scroll display. Automatic screen blanking to reduce possibility of burn. Briefcase size: 17" x 7" x 2". Weight: under 4 lbs.

To:
RCA MicroComputer Products
New Holland Avenue
Lancaster, PA 17604



Please send me the APT brochure with complete specifications.

Name _____

Title _____

Company _____

Address _____

City _____ State _____ Zip _____

For more information or to order, call 800-233-0094.
In Penna., call collect to 717-393-0446.

BYT-883

APL

APL, for those who don't know, is an interpreted language (like LISP or BASIC). It makes use of many curious symbols, such as squashed squares and bent arrows. It is very powerful. You can multiply matrices with a single command, invert them with another, and do transformations of the results with two more commands. A single line of APL code can do complex arithmetic, logs, trigonometry, and fairly complicated logical operations. Alas, APL has been described, with good reason, as a "write only" language: you're just not likely to understand your program an hour after you've written it. Used interactively, though, it's hard to beat.

I foresee a place for APL in the microcomputer future: it will turn small computers, especially portables, into *very* powerful desk calculators. It will already run on an Osborne 1, I understand that they're working on a version for the Otrona, and I expect that trend to continue. If someone will write a good in-

troductory text, and APL implementers will do good tutorials with lots of examples, it's possible that APL will become quite popular for quick-and-dirty problem solving. It won't ever be as popular as BASIC for calculator-like computation, but it will contend with it.

FORTH and LISP

I expect LISP to absorb FORTH. Not completely, of course, because nothing ever wins completely; but I know of nothing you can do with FORTH that you can't do with LISP, while LISP lets you do a lot that FORTH can't even approach.

FORTH is sometimes used to write operating systems, and was for some time the only powerful language available to Atari programmers. Like LISP, FORTH boasts a number of fanatic adherents. My mad friend used to say that FORTH was a kind of assembly language that used the programmer as a preprocessor.

LISP (LISt Processing language) was one of the earliest "higher level" computer languages. It was written

by John McCarthy in the 50s and has dominated the artificial intelligence field ever since. It's a very strange language, using peculiar notation and *lots* of parentheses; but it's very powerful.

The main problems with LISP are (1) it's hard to learn from books, although not so hard to learn if you've access to people who already use it, and (2) it uses memory like mad, so that there haven't been good LISPs for microcomputers.

FORTH has some similarities to LISP but doesn't use as much memory. People I respect have convinced me that LISP is much more powerful than FORTH. Having half learned both LISP and FORTH, it's my opinion that they're equally difficult to master; both require a good bit of concentration, and you have to work until something clicks—what the Gestalt psychologists call "the Aha! experience." They're also rather easy to forget if you don't use them regularly.

Incidentally, those who'd like "a LISP experience" without much in-

INTERSTELLAR DRIVE™

A SOLID STATE DISK EMULATOR



SAVE MONEY!
Increase your
computer's productivity

The INTERSTELLAR DRIVE is a high performance data storage subsystem with independent power supply, battery backup, and error detection. It has 256KB to 1 Megabyte of solid state memory integrated to perform with your operating system.

Save valuable time!
5 to 50 times faster
performance than floppy disks
and Winchester drives

PION'S INTERSTELLAR DRIVE is designed for use with a family of interfaces and software packages. Currently available are interfaces for IBM, S100, TRS80, Apple, SS50, and most Z80 uP, and software for most popular operating systems. Additional interfaces are continually being developed for the most popular computers.

Basic Price for 256KB unit [Includes Interface and software]

\$1095. plus tax (where applicable) and shipping

Visa and Master Card accepted.



PION, INC.

Tel. (617) 923-8009

101R Walnut St., Watertown, MA 02172

TRS80 trademark of Tandy Corp. Apple trademark of Apple Computers
Interstellar Drive trademark of PION, Inc.

Don't take no for an answer!

WINCHESTER CARTRIDGE DISK DRIVES FOR MICROCOMPUTERS

Feature	DMA Systems 5¼" Drives	3.9" Drives	Other 5¼" Drives
Now in production	yes	no	no
Data interchange	yes	no	no
Contamination control	yes	no	no
Retractable heads	yes	no	no
Standard cartridge	yes	no	yes
40 ms access time	yes	no	no
5 Mb capacity (formatted)	yes	yes	yes
Capacity growth capability	yes	no	no
Removable-only drive	yes	yes	yes
Fixed/Removable drive	yes	no	no

A comparison of Winchester cartridge disk drives shows there's really no comparison.

Only DMA Systems allows you to interchange data between drives.

Only DMA Systems has a unique retractable head that ensures data integrity by never touching the disk.

Only DMA Systems has a self-sealing clean air system that prevents contaminants from reaching the data—even after thousands of insertions.

And only DMA Systems gives you a choice of fixed/removable or removable-only drives. Both models match mini-floppy front panel dimensions and adapt to existing 5¼" Winchester drive controllers.

What's more, DMA Systems is the only manufacturer delivering

microcomputer Winchester cartridge disk drives.

But DMA Systems drives don't just outperform other cartridge systems. They outperform all other types of microcomputer backup.

Consider the alternatives...

Floppies have low capacity, poor reliability and slow access time.

Streamers are unreliable and can't provide random access.

There's only one drive manufacturer who can answer "yes" to all of your needs: DMA Systems.

For more information write DMA Systems, 601 Pine Avenue, Goleta, CA 93117. Or call (805) 683-3811, Telex 658341.

DMA SYSTEMS

Just what the industry needs.



CARTRIDGE RIBBONS FOR
APPLE PRINTERS
NEC 8023A
C. ITOH PROWRITER

\$9.95 EA. \$107.46 DOZ

CARTRIDGE RIBBONS FOR

EPSON
MX-80 MX-100

\$6.99 EA. \$11.95 EA
\$86.29 EA. \$75.49 DOZ

DUAL SPOOL RIBBONS FOR

OKIDATA
PRINTERS

80, 82, 83 EA DOZ
92, 93 \$2.75 \$29.70
84 \$5.99 \$64.69

LABEL
SPECIAL

\$2.99
(5K MIN) /K

1 ACROSS 3" x 15/16 CONTINUOUS LABELS

MAXELL
DISKETTES

5 1/4" SINGLE SIDE
DUAL DENSITY
MD-1

\$29.90
10 PACK

INNOVATIVE
CONCEPTS

FLIP'N'FILE

DISC STORAGE BOX
HOLDS UP TO 60 DISKETTES

5 1/4" 8"
\$24.95 EA **\$29.95** EA

COMPLETE LINE OF OTHER RIBBONS AVAILABLE. PLEASE CALL

ALL ABOVE PRICES INCLUDE SHIPPING

Check-Mate™



51 DIAUTO DR. P.O. BOX 103
RANDOLPH, MA 02368

TOLL FREE 800-343-7706 IN MASS 617-963-7694

WE ACCEPT MASTER CARD & VISA
MASS. RESIDENTS ADD 5% SALES TAX
PHONES OPEN 9AM-7PM EASTERN TIME



vestment should get Daniel P. Friedman's *The Little LISPer*. This rather odd book "is a programmed text based on lecture notes from a two-week 'quickie' introduction to LISP for students with no previous programming experience and an admitted dislike for anything quantitative." It has to be experienced to be appreciated; I found myself alternately fascinated and throwing the book across the room. It certainly shows—not tells, but shows—you a lot about LISP.

As memory gets cheaper, small computers get more powerful, and communications get simpler, I expect many publishers will offer better LISP interpreters (and compilers; LISP is a hybrid, with the possibility of both interactive-interpretive mode and compiled mode), as well as more online tutorials, so that LISP will be easier to learn. FORTH and LISP users both tend to be fanatics. I'm neither, so it's only an informed guess, but I suspect that as LISPs get more common, LISP will get the bulk of the recruits who would otherwise have gone to FORTH.

COBOL and FORTRAN

Every time I say anything negative about COBOL, I get half a dozen letters reminding me that there are many billions of dollars' worth of COBOL programs. Surely those won't go away?

I think they will. Not instantly, and I doubt that COBOL will vanish entirely, but I do not see a large place for COBOL in the microcomputer world. If it were going to catch on, it would have by now; and it just hasn't. That, in my judgment, is just as well. COBOL is a language whose time has passed. It doesn't force readable code, it takes experts to maintain large COBOL programs, and it doesn't have most of the features required for structured programming.

It does do certain things well. COBOL has built-in commands for sorts and merges and other fairly complex operations. On the other hand, it's not hard to translate well-written COBOL programs into some other language, such as Pascal, while

The Bell 212 Modem for the S-100 Bus has Arrived

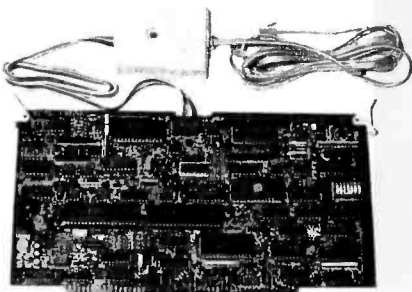

PMMI & Racal Vadic joined forces to bring you the first Bell 212A-compatible modem for the S-100 bus. The MM-212 is a top quality modem designed to meet all physical, electrical & timing requirements of the IEEE 696/S-100 specification. FCC registered for direct connection to the telephone line.

UNBEATABLE FEATURES:

- Bell 212A (1200 baud) or Bell 103 (45.5-300 baud) modes
- 1200 baud synchronous & asynchronous
- Access to PMMI's 24 hour a day test center
- Microprocessor based design
- Auto answer and auto dial
- Five year limited warranty
- Full or half duplex
- Maskable interrupts
- Self test modes

FOR FURTHER INFORMATION, call or write for free brochure or send \$10⁰⁰ (refundable w/purchase) for MM-212 Owner's Manual.



COMMUNICATIONS

5201 Leesburg Pike, Suite 604
Falls Church, VA 22041
(703) 379-9660

DEALER & OEM
OPPORTUNITIES AVAILABLE

PMMI modems' performance proves

ALL MODEMS ARE NOT CREATED EQUAL

Look over the Rainbow.

Learn Rainbow™ computer-based instruction ends manual labor. No slaving over computer manuals, you learn to use the Rainbow on screen, in minutes, not months.

One of the Rainbow's best features is the service and support from Digital, the world's second largest computer company.

The Rainbow's sleek, comfortable keyboard with standard typewriter keypad fits almost anywhere, even on your lap.

Of the hundreds of software applications now available many are Digital Classified and serviced.

The Rainbow shows more character, 132 columns instead of the usual 80. So you can screen a 12 month spreadsheet, without losing 6 months.

Keyboard is designed with separate function groups and special keys like "HELP", "DO", and "NEXT SCREEN".

Only the Rainbow automatically runs the widest range of the popular 8-bit and 16-bit CP/M® software.

After you look over the Rainbow™ personal computer on paper, look over the Rainbow in person. To learn where, call 1-800-DIGITAL or write Digital Equipment Corporation, 200 Baker Avenue, Concord, MA 01742.

Not even the world's largest computer company gives you so much. But the second largest does.

digital

© Digital Equipment Corporation 1983
CP/M is a registered trademark of Digital Research, Inc.

Circle 142 on inquiry card.

www.americanradiohistory.com

If you stick with timesharing after reading this ad, you haven't read this ad.

Typically, financial planning on a timesharing service runs \$2,000 a month and more. Month after month after month.

And it doesn't take a spreadsheet to figure that as a \$24,000-a-year-after-year expense.

The incredibly cheap alternative.

The Financial Planner™ from Ashton-Tate can stop this cash drain once and for all.

You pay \$700 — one time — for the Planner. And handle your financial planning quickly, easily and completely on your microcomputer.

Without having to share your time or your money with anyone.

A forecaster's dream come true.

The Financial Planner has enough depth to solve the most complex business problems you can foresee, yet can be used almost intuitively.

The Planner automatically performs calculations on individual items, rows, columns and entire models. Understands conditional logic. Solves simultaneous equations. Computes Present Value and Internal Rate of Return. Reads and writes dBASE II™ files. And much, much more.

But you use abbreviated names, not mysterious formulas. And you communicate with the computer in the English-like vocabulary of FPL™ (Financial Planning Language), so you can easily set up your budgeting and evaluation models.

Editing and report-writing are an integral part of the package, and you can preview results on the screen, then produce presentation-quality financial reports directly.

And when you have your models and reports just right, you can automate them so even your President can run them.

With the Planner, you produce P & L forecasts and financial consolidations in minutes. Explore



“what if” alternatives. Analyze new business ventures and mergers. Plan real estate acquisition and development. And fine tune operations until you reach the financial objectives you've set.

It's one of the most comprehensive business tools available on any computer. All for a fraction of what you've been spending on timesharing services to do the same things.

For the ardent skeptics.

It may sound too good to be true, but you can check out the Financial Planner with no financial risk.

Run through a hands-on demo at your nearest computer or software store. Then take a package home and use it for 30 days on your IBM PC or CP/M microcomputer. If it's not everything we said it was, just return it and you'll get your money back.

For the name of your nearest dealer, contact Ashton-Tate at 10150 West Jefferson Boulevard, Culver City, CA 90230. Or better yet, call (213) 204-5570 today.

Time's a-wasting.

**The
Financial
Planner™**

ASHTON · TATE ■

those programs not easily translated are generally almost impossible to maintain. For that matter, you can call some of those splendid special routines, such as Sort, from inside languages like Modula-2 . . .

FORTRAN is another language that won't go away entirely, but will, I think, fade into the background. For a while it looked as if FORTRAN, augmented by the RATFOR (Rational FORtran) preprocessor, might stake out a large place in microcomputerland, but that didn't happen.

FORTRAN, which is very useful for crunching lots of numbers, is not all that well designed for anything else. You can write complex text-oriented programs in FORTRAN; the original Crowther and Wood Adventure of the Colossal Cave was written in FORTRAN. It wasn't designed for that, though, and FORTRAN programmers usually must resort to tricks to make it handle text well.

Because so very many COBOL and FORTRAN programs are in existence, neither language will die; but as time goes on, most of those

programs will be translated into other languages with better structural features, while fewer and fewer programmers will use either language for writing new programs for microcomputers.

PL/I

The PL/I programming language is very popular among mainframe and large minicomputer programmers. It was one of the earliest of the "higher level" languages and one of the first designed to allow formal structuring. It has good string handling, relatively good portability, and better input/output and file handling than Pascal.

In fact, considered a feature at a time, PL/I sounds nearly ideal. My late mad friend found it so attractive that he wrote nearly all his programs in it.

There is a good implementation of PL/I for CP/M microcomputers; what's more, it's not likely to go away. Dr. Gary Kildall, president of Digital Research and author of CP/M, is a PL/I enthusiast. Much of

the original CP/M was written in a subset of PL/I. Kildall has committed Digital Research to provide PL/I for all CP/M upgrades; this presumably includes new systems based on the 68000 and 8086 chips.

Despite these advantages, PL/I hasn't caught on in the microcomputer world. Joan K. Hughes wrote one of the standard PL/I textbooks (*PL/I Structured Programming*) but wrote all the programs for her microcomputer consulting firm in CBASIC because PL/I was not then available for CP/M microcomputer systems; later, she found that she had too much invested in CBASIC programs to change over.

Then, too, many computer users—including myself—do not find PL/I programs readable, nor is the language easily learned. "Easily" is, of course, a relative term; PL/I is not much harder to learn than, say, FORTRAN. It has many more statements than Pascal, but PL/I programmers find that a desirable feature.

Like CB-80, PL/I requires separate compile and link operations, but

Marymme INDUSTRIES, INC.

In Texas Orders
Questions & Answers
1-713-392-0747

22511 Katy Freeway
Katy (Houston) Texas 77450

To Order
1-800-231-3680
800-231-3681

SAVE BIG DOLLARS ON ALL TRS-80[®] HARDWARE & SOFTWARE

TRS-80[®] BY RADIO SHACK. Brand new in cartons delivered. Save state sales tax. Texas residents add only 5% sales tax. Open Mon.-Fri. 9-6, Sat. 9-1. We pay freight and insurance. Come by and see us. Call us for a reference in or near your city. Ref: Farmers State Bank, Brookshire, Texas.

WE OFFER ON REQUEST

- Federal Express (Overnight Delivery)
- Houston Intercontinental Airport Delivery (Same Day)
- U.P.S. BLUE (Every Day)
- References from people who have bought computers from us probably in your city. We have thousands of satisfied customers. WE WILL NOT BE UNDERSOLD!

ED McMANUS

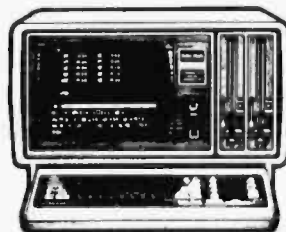

No Tax on Out of Texas Shipments!

Save
10% 15%
OR MORE

Telex 77-4132 (Fleks Hou)

See us in the Wall Street Journal every Tues., Wed., and Thurs.

[®] TRS-80 is a Registered Trademark of Tandy Corp

WE ALWAYS OFFER

- We accept Master Card, VISA, and American Express.
- We use Direct Freight Lines. No long waits.
- We always pay the freight and insurance
- Toll free order number
- Our capability to go to the giant TRS-80[®] Computer warehouse 5 hours away, in Ft. Worth, Texas, to keep you in stock.

JOE McMANUS



both are relatively straightforward. When PL/I first came out, the only manuals were written in the early Digital Research style of high density and low readability, while CBASIC had remarkably clear documentation. This may have contributed to CBASIC's early ascendancy.

The newest Digital Research PL/I manuals have been completely rewritten. They are clear, readable, and filled with examples. A lot of mini-computer programmers are quite familiar with PL/I. Therefore, now that the distinction between micro and mini is becoming blurred, it's possible that PL/I, despite its relatively late start, will experience rapid new gains in popularity. The language certainly can't be counted out.

The C Programming Language

The "C" language was developed at Bell Laboratories. Until recently its fate was intimately dependent on the future of the Unix operating system. In the past couple of years, though, CP/M versions of C have appeared. One, Leor Zolman's BDS C Compiler, almost single-handedly made C a formidable contender because many useful programs were written in it.

BDS C had severe limits; now lots of C compilers without those limits are available. In addition, CP/M-68K, the CP/M operating system for machines using the 16-bit 68000 processor chip, comes with a limited C compiler. This will undoubtedly stimulate new users to learn something of the C language.

C is popular, and both C and the Unix operating system have fanatical supporters. The language is powerful and is certainly easier to learn than assembly language.

The drawback is readability. C programs are not self-documenting; one could argue that there ought to be at least one comment for each line of code. Alas, the programs are *almost* readable, and while one is writing C programs the purpose of each line is quite clear, so that further comments seem silly and are often omitted. Six weeks later the program is nearly incomprehensible.

A second problem with C—at least

with the compilers I have been able to work with—is that it generates *very* large programs. For example:

```
/* A Very Simple Program. */
main ( )
{ printf("This is a very simple
  program. \n");
}
```

is a program that merely prints the quoted message. (The \n specifies a "newline," i.e., carriage return and linefeed.)

We compiled it with Lattice C, which is a well-regarded C compiler. The program itself is 384 bytes long. It compiles into 178 bytes of object code. It must be linked to turn it into a command file before it can be run. That produces a program 11,008 bytes long. This seems excessive.

When we installed our M-Drive (a "silicon disk" program that deludes the computer into believing that extra memory is a *very* fast disk drive), we required a program to format the "memory disk." The program furnished us by Compupro was written in Whitesmiths C and was 16K bytes long. Tony Pietsch found this absurd and wrote a format program in assembly language: it was only 487 bytes long.

There are good reasons for this obesity. The C language was originally intended for use with the Unix operating system, and much of the seemingly excessive code that must be packed into programs compiled in C is there to compensate for the missing Unix. We may understand this and still be unhappy at the code size. There may be implementations that don't generate superfluous code, but we haven't come across one.

C has become increasingly popular—with fanatic supporters. It will certainly survive. However, I don't expect it ever to become a highly popular language, and if I had to bet on its future, I'd say that it will take a respectable niche, after which its growth will be quite slow in comparison to the microcomputer world in general.

Until recently, those interested in learning more about the C language

pretty well had to read *The C Programming Language* by Brian Kernighan and Dennis Ritchie. This book is better written than many computer texts, but it isn't easy reading, and it was never intended for microcomputer users.

I have recently received *C Programming Guide* by Jack Purdum. I found this much clearer than Kernighan and Ritchie. Purdum's book has plenty of illustrative examples and even compares C programs with similar programs in BASIC. It recognizes that many readers will be using CP/M systems and explains some of the problems they may encounter. There's a very good discussion of pointers; this is especially welcome because C makes extensive use of pointers. I recommend this book to anyone interested in learning more about the C language. Read it *before* trying to tackle Kernighan and Ritchie.

I have a large number of C compilers and hope to do an extensive comparison of them for a future issue.

Pascal and Modula-2

Pascal has been the real success story in microcomputing. Last year more books were published about Pascal than about BASIC. (By books, I mean titles; there were probably more copies sold of BASIC books than Pascal books.)

The Pascal language was devised by Prof. Niklaus Wirth of Zurich. It was originally intended as a teaching language that would force students to write readable, structured programs, and thus train them to think about programming in a logical way. It generated a number of enthusiastic converts who developed Pascal into a practical language. The structured features caused many program bugs to be caught by the compiler, so that once a program written in Pascal is made to run, it often runs properly without much debugging.

Pascal is now taught in many universities. Some even require Pascal proficiency for graduation in any science. Pascal courses are found in high schools, and that practice is also spreading. Thus the language

COMMODORE 64 \$189.95*

COMMODORE 64 Computer—only \$189.95*
*when purchased with any of these three packages.

COMMODORE 64	\$189.95
with the purchase of	
1 1541 Disk Drive	\$299.95
1 1525E Printer	\$289.95
ALL FOR	\$779.95

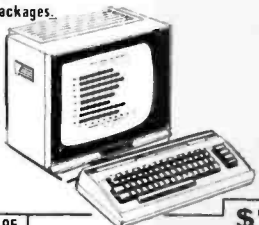

COMMODORE 64	\$189.95
with the purchase of	
1 1541 Disk Drive	\$299.95
1 1701 14" color monitor	\$299.95
ALL FOR	\$789.95

COMMODORE 64	\$189.95
with the purchase of	
1 1541 Disk Drive	\$299.95
1 1526 Fast printer-includes IFC/cable direct connect to 64	\$349.95
ALL FOR	\$839.95

COMMODORE VIC-20	\$749.95*
with the purchase of	
1 Datasette program recorder	\$69.95
1 Gortek educational software	\$24.95
All for	\$169.95

Software for Commodore 64 & VIC-20 at discount! Call us!

DATA 20 Accessories

- Z-80 card For Commodore 64 \$269.95
- 80 column card For Commodore 64 169.95
- 40 column card For VIC-20 99.95
- 40 column card w/8K mem built-in for VIC-20 139.95
- Video Pack 64K For VIC-20 329.95

FREE with the purchase of each of the above () products—Word Master/word processing software, Mailing List software & Telecommunications software.

ROYAL ALPHA 2001
CP/M, color graphics, 3 video outputs—
RGB for hi res 80 col color displays
composite video: use with any regular
monitor; modulated RF for use with your TV.
Centronic printer port, 40/80 col display,
KC std audio cass. port RE: \$695.00 Your cost:
\$489.95

TI COMPACT COMPUTER CC-40 only \$19995
Most advanced portable, fits in your briefcase!
Will perform as well as the \$1000 unit!
One set of A batteries = 200 hours of operation (approx)
HX-1000 Printer/plotter \$179.95
HX-2000 Watertape (digital tape drive) \$124.95
RS-232 Interface 89.95
HX-3000 RS-232 int. w/parallel IFC 109.95
Solid state software/watertape software-call us!

Texas Instruments Home Computer TI-99/4A

\$9995*



NET after \$50 rebate from TI
You pay us \$149.95!

Peripheral expansion box	\$199.95
RS-232 card	139.95
Disk controller card	199.95
Expansion Sys. disk drive	319.95
Memory expan. card (32K)	229.95
P Code card (req. exp. card)	199.95
Telephone modem	159.95
Color monitor	339.95
Extended Basic	79.95
LOGO	89.95

DON'T BUY ANY PORTABLE COMPUTER UNTIL YOU SEE THE NEW COMMODORE!

*** COMMODORE'S SX-100 PORTABLE! ***
COMPLETELY PORTABLE!

- ★ Full 64K
- ★ Color Monitor built-in
- ★ Disk drive built-in
- ★ FREE software package
- ★ Completely compatible with the Commodore 64
- ★ LOTS OF SOFTWARE AVAILABLE!

\$995.00

GET THE BEST!

Original retail \$295.00!

MATTEL ELECTRONICS INTELLIVISION

\$4995** Net price after \$50 rebate from Mattel.**

You pay us \$99.95

** To qualify for Mattel rebate you must purchase two game cartridges with the Model 2609

DISKETTES	In packs of 10
Memorex 5 1/4"	SS/DD \$24.85
Verbatim	SS/DD 29.45
Maxell	SS/DD 33.95

HP-75C HEWLETT PACKARD Handheld computer \$729.95

HP-12C Financial calculator	99.95
HP-11C Scientific calculator	73.95
HP-10C Scientific calculator	58.95
HP-15C Scientific calculator	99.95
HP-16C Financial/business calc.	99.95
HP-97 Programmable print calc	595.00
HP-41C Programmable calc	158.95
HP-41CV Programmable calc	213.95
Optical wand	97.95
Printer for 41CV	283.95
Card reader for 41CV/C	152.95
IL thermal print/plotter	389.95
Video interface (HP 82163A)	249.95
HP IL Systems on hand	
IL interface module	99.95
Digital cassette drive	439.95
Extended function mem mod	61.99
Extended memory module	61.99
Time module	61.99
Memory module for 41C/CV	25.00
Quad memory mod for 41C	65.00

COMPUTER PRINTERS & MONITORS

Diablo 620 Letter quality, 25 cps	\$ 999.95
Diablo 620 Letter quality, 40 cps	1799.95
NEC 8023A 100 cps with tractor	499.95
Transtar Color printer, 30 shades, 50 cps	499.95
Okidata 82A Graphics 120 cps bi-directional	424.95
Okidata 83A Par/Ser., 120 cps, friction/tractor	664.95
Okidata 92P 160 cps, graphics, bi-directional	539.95
Okidata 93P 160 cps, graphics, frict/tract, letter quality	889.95
Star Gemini 10 100 cps, 2.3K buffer, Epson comp.	369.95
Star Gemini 15 100 cps, 15", 136 col, 2.3K buffer	489.95
Zenith 12" green monitors, good resolution	99.95
Sanyo 15" b/w monitor, high res-below cost!	169.95
IDS Model 480	529.95
IDS 80 column color printer/all options	1595.00
IDS 132 columns color/all options	1695.00

ATARI

ATARI COMPUTERS AT BELOW COST

Atari 400-16K \$8995*
*after \$50.00 rebate & free software (you pay us \$189.95)

Atari 800-48K \$27995*
*after the \$100.00 rebate (you pay us \$379.95)

Atari 1200XL-64K \$39995*
*after \$100.00 rebate (you pay us \$499.95)

410 Recorder	\$ 84.95
810 Disk Drive	449.95
850 Interface module	169.95
Programmer Kit	49.95

ATARI SOFTWARE at Discounted prices!

CASIO NEW LINE OF CASIO WATCHES

LW6 Ladies' water sports, 150 ft, calendar, second display	\$19.95
LW601C Ladies' water sports, 150ft, S/S case, alarm, calendar & more!	34.95
AQ200 Analog, Seiko Digiana type, dual time, calendar, alarm, stop watch, h/ry time signal, chrome plated, beautiful!	29.95
A661G Men's chrono/alarm/dual time, goldtone, all metal	29.95
A656 Alarm/chrono-dual time, silvertone	24.95
C583 Calculator watch, "E" sign, alarm, chrono, constant	29.95
GM30 Game watch, sophisticated at great discount! Ltd. quan	29.95
GM40 Game watch, great game at discount! Limited quantity!	24.95
F85 AM/PM, calendar to 2009, dual time mode, stop watch!	14.95
CS831 Calc watch, "E" sign, alarm, stop watch, constant w/chrome plated case & more!	39.95

Panasonic

Telephone Answering Machines

KXT 1505 Vox dual cassettes 99.95
KXT 1515 Voice actuation, dual cassettes, remote 139.95
KXT 1521 Voice, remote, dual cassettes, etc. 189.95
KXT 1525 Voice act. Remote, dual cassettes, OGM 219.95
KXT 1530 Microprocessor, voice, remote, top of line! 319.95
NEW, CORDLESS TELEPHONE Model 3830 179.95
Compact & sophisticated—auto redial & more!

Sugg. Re: SONY CORDLESS TELEPHONE \$159.95
\$299.95 Model SPP-11 Innercom, auto. redial, rechargeable & more. High quality unique Sony design.

FIRESTICK Super Antenna increases cordless phone range 10 to 20 times \$49.95

NEW CORDLESS PHONE! "Remote Phone"
High quality-750 ft. range, rechargeable, last number re-dial, paging. Y/C: \$79.95



olivetti LEADS THE WAY

Electronic Typewriters/Computer Printers
The incredible NEW PRAXIS 41!
Heavy duty office typewriter ready to interface & use as a letter-quality computer printer! Multi-language (French, Spanish, Italian, German, English), three pitch (Pica 10, Elite 12, Micro 15). This unit out-performs many \$1200.00 typewriters. Comes with computer port built-in, opt'l serial or parallel interface available \$499.95

ROYAL ALPHA 2001 ELECTRONIC

Great unit for HEAVY DUTY WORK!
Decimal tab, dual pitch & more! \$399.95
Sugg. List: \$695.00 FOR THE FIRST TIME

TIMEX TS-1000 \$44.95

16K RAM 45.95
Printer by Timex 89.95
Call us for Timex software—buy 4 software/get 1 software free!

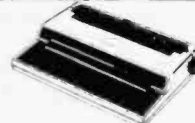

brother YOU'VE GOT TO TRY THIS TO BELIEVE IT! FITS IN A BRIEFCASE - AC/DC - GREAT

Personal Electronic Typewriter

EP-20 Dot Matrix printing on standard typing paper • Bright 10-digit display with print/no-print modes • Upper & lower case lettering plus international symbols • Calculations in 4 basic math functions • Operates on flashlight batteries or AC adaptor • Compact and lightweight (5.1 lbs.), fits into a briefcase



Incl. batt \$159.95

VERY QUIET - PERFECT FOR USE BY STUDENT, ETC. IN THE LIBRARY, STUDY HALL, WHEREVER! Optional AC adaptor \$12.95

SANYO

NEW FABULOUS SANYO COMPUTER MBC-555
IBM PC Compatible, uses IBM software, 8088 CPU, 128K memory, 160K disk storage, color graphics, centronic port, 80 column, MS/DOS Basic, diagnostics, utilities, speaker, joystick port, word processing & spread sheet software included.
Retail: \$995.00 call for best price! Optional: 128K RAM expansion, 320K to 640K drives, 8087 number cruncher, RS-232 hard disk available & more!
Place your order today!

EPSON MX-80FT \$449.95

FX-80 160 cps call for price
RX-80 100 cps call for price (NEW!) (Replaces MX-80)
MX-100 call for price!

OLYMPIC SALES COMPANY

P.O. Box 74545 216 S. Oxford Ave. Los Angeles, CA 90004
Phone (213) 739-1130 Cable "OLYRAV" LSA Telex: 67 34 77

Order Desks: 7:00 AM to 7:00 PM Mon thru Sat—TOLL-FREE: (out of CA) 800-421-8045 (in CA) 800-252-2153 TELEX: 67 34 77 CABLE: "OLYRAV" LSA
Goods subject to availability. This ad supersedes all previous ads. FOB our warehouse; prices subject to change without notice, not responsible for typographical errors, all orders subject to verification, minimum shipping & handling \$5.95 Send for our catalog—\$2 domestic, \$5.95 foreign. Some of the goods not available all stores—Call first to be sure!



"THE ORIGINAL BIG BOARD"
OEM - INDUSTRIAL - BUSINESS - SCIENTIFIC
SINGLE BOARD COMPUTER KIT!
Z-80 CPU! 64K RAM!
 (DO NOT CONFUSE WITH ANY OF OUR FLATTERING IMITATORS!)

NEW!

NEW LOWER PRICES

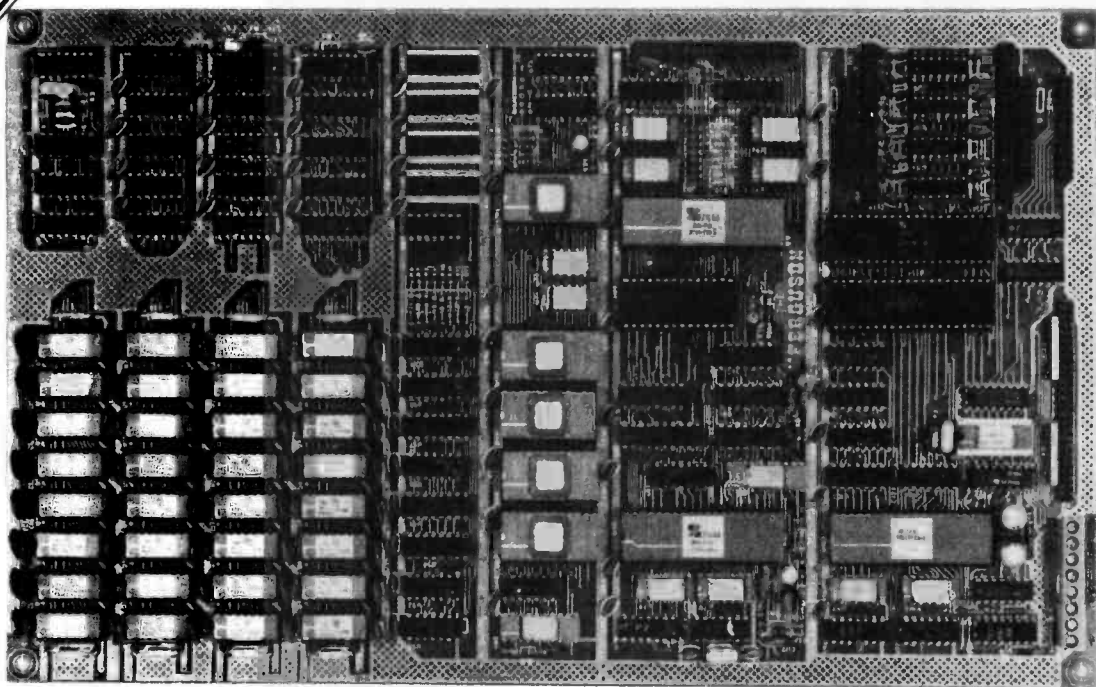

PARTIALLY ASSEMBLED KITS
 For All Sockets Installed
 And Soldered Add \$50.
 (Not For Blank PCB)

WANT MORE INFO?
 Full Documentation and
 Schematics — \$5.

THE BIG BOARD PROJECT: With thousands sold worldwide and over two years of field experience, the Big Board may just be one of the most reliable single board computers available today. This is the same design that was licensed by Xerox Corp. as the basis for their 820 computer.
 The Big Board gives you the right mix of most needed computing features all on one board. The Big Board was designed from scratch to run the latest version of CP/M*. Just imagine all the off-the-shelf software that can be run on the Big Board without any modifications needed.

\$319⁰⁰** (64K KIT BASIC I/O)

SIZE: 8 1/2 x 13 3/4 IN.
 SAME AS AN 8 IN. DRIVE.
 REQUIRES: +5V @ 3 AMPS
 +- 12V @ .5 AMPS.

FULLY SOCKETED! FEATURES: (Remember, all this on one board!)

64K RAM

Uses industry standard 4116 RAM's. All 64K is available to the user, our VIDEO and EPROM sections do not make holes in system RAM. Also, very special care was taken in the RAM array PC layout to eliminate potential noise and glitches.

Z-80 CPU

Running at 2.5 MHZ. Handles all 4116 RAM refresh and supports Mode 2 INTERRUPTS. Fully buffered and runs 8080 software.

SERIAL I/O (OPTIONAL)

Full 2 channels using the Z80 SIO and the SMC 8116 Baud Rate Generator. FULL RS232! For synchronous or asynchronous communication. In synchronous mode, the clocks can be transmitted or received by a modem. Both channels can be set up for either data-communication or data-terminals. Supports mode 2 Int. Price for all parts and connectors: \$39.95

BASIC I/O

Consists of separate parallel port (Z80 PIO) for use with an ASCII encoded keyboard for input. Output would be on the 80 x 24 Video Display.

BLANK PC BOARD — \$119

The blank Big Board PC Board comes complete with full documentation (including schematics), the character ROM, the PFM 3.3 MONITOR ROM, and a diskette with the source of our BIOS, BOOT, and PFM 3.3 MONITOR.

24 x 80 CHARACTER VIDEO

With a crisp, flicker-free display that looks extremely sharp even on small monitors. Hardware scroll and full cursor control. Composite video or split video and sync. Character set is supplied on a 2716 style ROM, making customized fonts easy. Sync pulses can be any desired length or polarity. Video may be inverted or true. 5 x 7 Matrix - Upper & Lower Case.

FLOPPY DISC CONTROLLER

Uses WD1771 controller chip with a TTL Data Separator for enhanced reliability. IBM 3740 compatible. Supports up to four 8 inch disc drives. Directly compatible with standard Shugart drives such as the SA800 or SA801. Drives can be configured for remote AC off-on. Runs CP/M* 2.2.

TWO PORT PARALLEL I/O (OPTIONAL)

Uses Z-80 PIO. Full 16 bits, fully buffered, bi-directional. Uses selectable hand shake polarity. Set of all parts and connectors for parallel I/O: \$19.95

REAL TIME CLOCK (OPTIONAL)

Uses Z-80 CTC. Can be configured as a Counter on Real Time Clock. Set of all parts: \$9.95

CP/M* 2.2 FOR BIG BOARD

The popular CP/M* D.O.S. to run on Big Board is available for \$139.00.

BIG BOARD SOFTWARE SPECIAL — \$149

Through special arrangement with CDL we offer a powerful package of TDL Z-80 software that has a suggested retail of almost \$600. Includes: Extended Disk Business Basic, ZEDIT text editor, MACRO II Macro Assembler, LINKER, DEBUG I and DEBUG II. Supplied on 8 in. diskette with extensive manual.

PFM 3.3 2K SYSTEM MONITOR

The real power of the Big Board lies in its PFM 3.3 on board monitor. PFM commands include: Dump Memory, Boot CP/M*, Copy, Examine, Fill Memory, Test Memory, Go To, Read and Write I/O Ports, Disc Read (Drive, Track, Sector), and Search PFM occupies one of the four 2716 EPROM locations provided. Z-80 is a Trademark of Zilog.

Digital Research Computers
 (OF TEXAS)
 P.O. BOX 461565 • GARLAND, TEXAS 75046 • (214) 271-3538

TERMS: Shipments will be made approximately 3 to 6 weeks after we receive your order. VISA, MC, cash accepted. We will accept COD's (for the Big Board only) with a \$75 deposit. Balance UPS COD. Add \$4.00 shipping.
 USA AND CANADA ONLY

*TRADEMARK OF DIGITAL RESEARCH. NOT ASSOCIATED WITH DIGITAL RESEARCH OF CALIFORNIA, THE ORIGINATORS OF CPM SOFTWARE
 **1 TO 4 PIECE DOMESTIC USA PRICE. Circle 145 on inquiry card.

has a secure place and is probably second only to BASIC in popularity among microcomputer users.

Pascal does have some very severe drawbacks, particularly as implemented for small computers. The original language had primitive (and not well-designed) input/output structures, so that most I/O has to be done through *extensions* to the language. The extensions have not been standardized, which compromises portability. (Portability refers to the ease of getting programs that run on one kind of machine to run on any other.) The language also has internal limits. Many of them have been discussed at length in previous columns.

Most of Pascal's deficiencies have been corrected in Niklaus Wirth's newest language, called Modula-2. As I write this, we don't have many implementations of Modula-2; but the two potential U.S. publishers of Modula-2 for microcomputers, Volition Systems of San Diego and Logitech of Palo Alto, promise new compilers Real Soon Now. Fortunately, the two companies are in communication and seem willing to agree on standard ways of extending Modula-2. They may set a de facto standard that newer publishers will have to meet, and thus avoid the cacophony of dialects that afflicts Pascal.

My experience has been that Pascal programmers tend to become Modula-2 enthusiasts. Much of the excitement and popularity of Pascal may thus be transferred to Modula-2. There are good reasons for this. Modula-2 is more powerful than Pascal and a lot easier to use. It is also very easy to translate Pascal programs into Modula-2; 90 percent or more of the work can be done by a translator program written in Modula-2. Add that Modula-2 is suitable for writing systems programs—I've seen a very powerful operating system written in Modula-2—and it's not hard to predict that Modula-2 will become increasingly more popular as it becomes available.

My own prediction is that Modula-2 will swallow a good chunk of both Pascal and C. So far not many experts join me in that fore-

Finally, investment software from Dow Jones.

Dow Jones & Company, publisher of *The Wall Street Journal* and *Barron's*, is proud to introduce **DOW JONES SOFTWARE™**

These products turn your personal computer into a powerful investment and business tool. With them, you can analyze and manage timely information available by telephone connection from the leading provider of online business and financial news and information, **Dow Jones News/Retrieval®**

DOW JONES SOFTWARE is reliable, easy-to-use, fully supported—from a company you can trust. Available at selected computer stores. For more information call 1-800-345-8500 Ext. 48 (Alaska, Hawaii and foreign call 1-215-789-7008 ext. 48)

DOW JONES SOFTWARE™

...Bank on it.

Copyright © Dow Jones & Co., Inc. All rights reserved.

Finally, portfolio management software from Dow Jones.

The **DOW JONES MARKET MANAGER™**

easily manages single or multiple portfolios with stock quotes from Dow Jones News/Retrieval®. Evaluate current positions and maintain a year-to-date record of all securities transactions. Now you can easily maintain all your records for concise portfolio evaluation. Available at selected computer stores.

HOLDINGS BY PORTFOLIO											
SYMBOL	DATE	USDT/ST	*****TRANSACTIONS*****			*****HOLDINGS*****			UNREALIZED		
Q	P		BUY	SELL	PRICE	AVAIL	PRICE	GAIN/LOSS	%		
A	APPL	Q	1/15/82	100	18.28	15.28	5,050	50	177	3,522	%
A	APPL	Q	1/15/82	100	18.28	15.28	2,000	50	177	3,522	%
A	APPL	Q	1/17/82	200	20.93	14.17	10,100	50	177	7,247	%
TOTAL APPL			400		3,921		20,200			14,279	
A	DEC	Q	1/12/82	50	4.128	82.56	5,865	117	174	1,775	%
A	DEC	Q	1/27/82	25	7.128	80.56	2,750	117	174	1,775	%
TOTAL DEC			75		6,287		6,994			2,567	
A	DJ	Q	2/18/83	50	4.057	33.14	2,514	50	100	862	%
A	DJ	Q	2/18/83	750	6.854	32.24	19,975	50	100	5,928	%
A	DJ	Q	2/18/83	75	7.584	31.92	3,778	50	100	1,214	%
TOTAL DJ			375		16,452		16,372			8,020	
A	IBM	Q	3/20/82	100	6.553	68.13	13,700	117		3,387	%
A	IBM	Q	5/20/82	50	3.182	63.44	3,850	117		2,448	%
A	IBM	Q	6/01/82	50	3.108	62.14	3,978	117		2,747	%
TOTAL IBM			200		13,632		21,500			10,792	
TOTAL			1,000		19,682		48,794			31,105	
VALUED 12/31/82 @ 1.000											
UNREALIZED GAIN/LOSS											
CASH BALANCE - 19444											

Holdings by Portfolio Reports display each tax lot valued to the stock market

DOW JONES SOFTWARE™

...Bank on it.

1-800-345-8500 Ext. 48

Compatible with Apple systems and the IBM PC.

Copyright © Dow Jones & Co., Inc. All rights reserved.

Items Cited

Augusta Computer Linguistics POB 390145 Mountain View, CA 94039		Not available
CB-80 Pascal MT+ with Speed Programming Package Digital Research POB 579 Pacific Grove, CA 93950 (408) 649-3896		\$500 \$500
Janus Compiler R&R Software POB 1512 Madison, WI 53701 (608) 244-6436	8080/8085 8088/8086	\$300 \$400
Lattice C Lifeboat Associates 1651 Third Ave. New York, NY 10028 (212) 860-0300		\$500

Books Cited

C Programming Guide Jack Purdum. Indianapolis: Que Corporation, 1983, 250 pages, software.		\$17.95
The Little LISPer Daniel P. Friedman. Palo Alto, CA: Science Research Associates, 1974, 64 pages, softcover.		\$3.95

cast, but I've seen nothing to make me change my views on the matter.

Ada

The Department of Defense estimated that if all DOD programs were written in a single language, the resulting savings would run to billions of dollars. After long consideration by a number of middle- and high-level committees, Ada was created to be *the* DOD programming language.

Ada will certainly have a large place in the computer world; any language supported by the Department of Defense would have to. As I've said before, learning to program in Ada is surefire job insurance.

Ada was designed by a committee, and it shows: it has *tons* of bells, whistles, features, and gimmicks. This tends to complicate the language, and some computer science experts have professed concern: given the complexity of Ada, how can you verify the language? That is:

can you be sure the compiler is doing all—and only—what you think it will, or can there be mysterious unintended side effects? If one side effect is to launch a missile without permission, all the savings resulting from Ada's creation could literally go up in smoke.

It's very hard to estimate Ada's future in the microcomputer world. No full Ada compilers for microcomputers are yet available, and this situation isn't likely to change for a while. I think Ada's future in microcomputerland depends in large part on just how quickly we get an Ada compiler we can use.

Incidentally, I have just received Augusta, a program that compiles a subset of Ada on the Z80. It has only just come, so I have been unable to compare it with Janus (the other Ada-subset compiler for microcomputer systems). Augusta seems to run, and the manual is written in clear English with numerous examples. It does not support pack-

ages, multitasking, real numbers, enumerated types, user-defined types and records, or exception error handling. I find the Janus documentation more complete and better organized, but this is impressionistic, not based on detailed objective comparison.

Bottom Line

If I had to pick a single language for future microcomputers, it would be Modula-2. That, however, is based on certain expectations about future Modula-2 implementations; just now (May Day 1983) I have no Modula-2 for CP/M systems.

If I were going to buy and learn one single language of those available today, I'd be hard put to choose. The two I'd consider would be CB-80 and Pascal MT+ with the Speed Programming Package. Both Pascal MT+ and CB-80 are expensive; the term "overpriced" is a value judgment I find myself tempted to use. Even so, I like Pascal MT+ somewhat better than I do the other Pascal implementations I have.

Deciding between Pascal and CB-80 isn't easy. Pascal, which also serves as a good introduction to Modula-2, is probably the more valuable to have learned over the long haul; but I find just now that I use CB-80 (and CB-86) more than I use Pascal.

It may be, of course, that I've missed the real contender; that Logo, Smalltalk, or some such will sweep the field. I don't think that will happen, but it isn't impossible.

The language debate will continue. ■

Jerry Pournelle welcomes readers' comments and opinions. Send a self-addressed envelope to Jerry Pournelle, c/o BYTE Publications, POB 372, Hancock, NH 03449. Please put your address on the letter as well as on the envelope. Due to the high volume of letters, Jerry cannot guarantee a personal reply.

Jerry Pournelle is a former aerospace engineer and current science-fiction writer who loves to play with computers.



Plug 3,000 new applications into your Apple.®

THE CP/M Card™ plugs CP/M Plus™ into your Apple. The CP/M Card gives you the option of running your Apple II with the speed and capability of a professional Z-80 system with CP/M*-compatible software. You plug in the CP/M Card. Then choose CP/M or your standard Apple software at your option.

Plug into a big, new world of software. The CP/M Card gives you instant access to the world's largest selection of microcomputer software — more than 3,000 CP/M-compatible applications, languages, and programming utilities. So, you, too can use professional business programs such as WordStar,[®] SuperCalc,[™] Condor,[™] and other high-performance software from Day One. Yet, you still have access to your present library of Apple software.

Plug into incredible performance. Together, the ultra-fast CP/M Card and CP/M Plus run applications up to

300% faster than your Apple system! The CP/M Card is the only Apple II performance package that offers the speed and efficiency of CP/M Plus.

A plug about quality.

The CP/M Card was designed and built by Digital Research, the creators of CP/M, and Advanced Logic Systems, the most respected manufacturer of Apple performance products. So you know the CP/M Card is the most perfectly integrated Apple performance package you can buy.

Why just keep plugging along? The CP/M Card provides everything you need — including 64K of on-board memory, CP/M Plus, CBASIC,[®] GSX[™]-80 and full documentation — for just \$399.

Now available through the CP/M library. See your local microcomputer dealer today. Or contact Advanced Logic Systems, 1195 East Arques Ave., Sunnyvale, CA 94086 (800) 538-8177. (In California (408) 730-0306.)

als

**Advanced Logic Systems
The CP/M Card for your Apple II.**

CP/M, CP/M Plus, the CP/M Card and CBASIC are either trademarks or registered trademarks of Digital Research Inc. Z-80 is a registered trademark of Zilog, Inc. WordStar is a registered trademark of MicroPro International Corporation. SuperCalc is a trademark of Sorcim Corporation. Condor is a trademark of Condor Computer Corporation. GSX-80 is a trademark of Graphics Software System. Apple is a registered trademark of Apple Computer, Inc. ©1982 Digital Research Inc.

Circle 12 on inquiry card.
www.americanradiohistory.com

SUPER SIX™

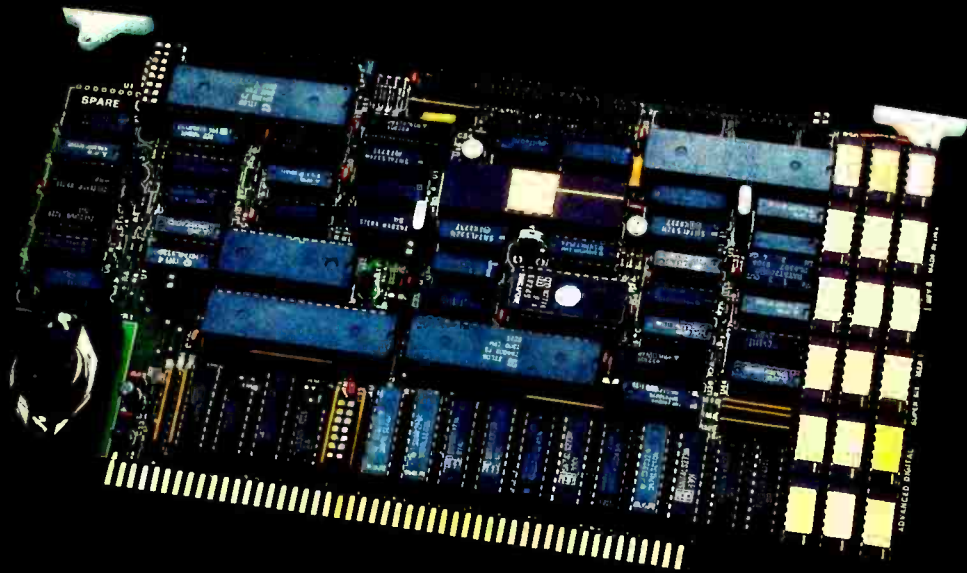

SUPER SIX, THE FIRST 6MHz S-100 SINGLE BOARD COMPUTER TO SUPPORT BANKED CP/M™ 3.0

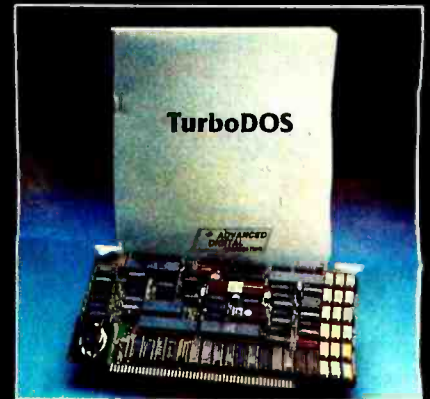
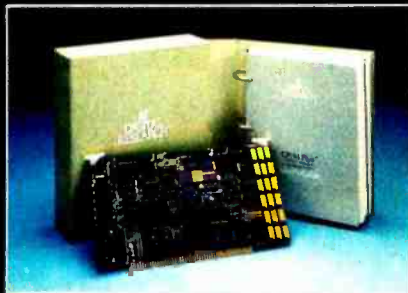

SUPER SIX FEATURES:

- 128 KB of Bank — selectable RAM
- 6 MHz, Z-80B CPU
- DMA Controller
- 6 MHz, Z-80B DART (2 Serial RS-232 Ports)
- 6 MHz, Z-80B PIO (2 Parallel Ports)
- 6 MHz, Z-80B CTC (Clock Timer)
- Double/Single Density Floppy Disk Controller — Supports 8" and 5-1/4" Drives Simultaneously
- 2/4 KB of Monitor EPROM
- S-100, IEEE 696 Compatible

SUPER SIX & CP/M™ 3.0 A PERFECT MATCH

Advanced Digital has found the perfect match to its powerful, high-speed SUPER SIX single board computer. It's Digital Research's new CP/M 3.0. Because of SUPER SIX's 128 KB of RAM, it is the only S-100 board to support CP/M 3.0 in the banked mode; or run CP/M 2.2 with 64 KB of extra buffer.

SUPER SIX & TurboDOS™ ANOTHER PERFECT MATCH

When you combine the TurboDOS multi-user operating system with the 6 MHz SUPER SIX, you'll find your system running 1-1/2 times faster than

before. Add the 4 MHz or 6 MHz SUPER SLAVE™ processor board(s) and you will have the fastest multi-user, multi-processor system available today.

See the SUPER SIX at your quality computer dealer or contact:



12700-B Knott Street
Garden Grove, CA 92641
Phone: (714) 891-4004
Telex: 678401 tab irin

*CP/M is a trademark of Digital Research Corp.
TurboDOS is a trademark of Software 2000 Inc.
SUPER SIX and SUPER SLAVE are trademarks of
Advanced Digital Corp.

Circle 10 on inquiry card.
www.americanradiohistory.com

The IBM PC and the Intel 8087 Coprocessor

Part 1: Overview and Floating-Point Assembly-Language Support

Addition of the 8087 chip to the IBM PC provides instant access to powerful floating-point, integer, and BCD arithmetic operations from assembly language

by Tim Field

The Intel 8087 Numeric Data Processor (NDP) is a coprocessor chip that greatly extends the calculation abilities of the Intel 8088 CPU (and Intel CPUs like the 8086, 80186, and 80286). The 8087, when attached to the 8088, performs a useful range of operations on a variety of data types much faster, more accurately, and with less trouble.

[Editor's Note: *The acronym CPU, which stands for central processing unit, is one that we usually do not use in BYTE because, for most material in the magazine, the word is more accurately replaced by the word "micro-processor."* In this situation, however, the 8088 micro-processor is the central processing unit in relation to the 8087 Numeric Data Processor. Because of this, we will use the acronym CPU to refer to the 8088 and NDP to refer to the 8087. . . .G. W.]

The IBM Personal Computer uses an Intel 8088 CPU and has an empty 40-pin socket just waiting for an 8087. With the 8087 NDP in place, you can immediately access it with software that explicitly issues the proper instructions to the 8087.

A great deal of confusion abounds concerning the level of support that IBM software currently provides for the

8087-enhanced PC. At one meeting of an IBM users club, a user said he had purchased an 8087, plugged it into the socket, and could not tell any difference in the execution speed of his BASIC programs. He was quite confused why the PC did not take immediate advantage of the new resource.

Unfortunately, things just are not that easy. As I write this article, the only high-level support of the 8087 in IBM software is in the new APL package. Pascal, BASIC, and the other IBM languages will not automatically execute using the 8087. IBM designed the hardware into the IBM PC and the IBM PC XT, but it is only beginning to support it officially.

For the moment, we must create our own software utility to make use of the 8087 in the IBM PC. This month, we will look at a piece of software called M8087 that makes it easy for the assembly-language programmer to add 8087 instructions to programs. Next month, we will use this assembly-language support to provide higher-level software support for the IBM Pascal Compiler.

While this article specifically discusses the 8087 interface with the IBM Personal Computer, the topics under

Processor Control Instructions

FINIT/FNINIT	Initialize processor
FDISI/FNDISI	Disable interrupts
FENI/FNENI	Enable interrupts
FLDCW	Load control word
FSTCW/FNSTCW	Store control word
FSTSW/FNSTSW	Store status word
FCLEX/FNCLEX	Clear exceptions
FSTENV/FNSTENV	Store environment
FLDENV	Load environment
FSAVE/FNSAVE	Save state
FRSTOR	Restore state
FINCSTP	Increment stack pointer
FDECSTP	Decrement stack pointer
FFREE	Free register
FNOP	No operation
FWAIT	CPU wait

Constant Load Instructions

FLDZ	Load + 0.0
FLD1	Load + 1.0
FLDPI	Load π
FLDL2T	Load $\log_2 10$
FLDL2E	Load $\log_2 e$
FLDLG2	Load $\log_{10} 2$
FLDLN2	Load $\log_e 2$

Transcendental Instructions

FPTAN	Partial tangent
FPATAN	Partial arctangent
F2XM1	$2^x - 1$
FYL2X	$Y \cdot \log_2 X$
FYL2XP1	$Y \cdot \log_2 (X + 1)$

Comparison Instructions

FCOM	Compare real
FCOMP	Compare real and pop
FCOMPP	Compare real and pop twice
FICOM	Integer compare
FICOMP	Integer compare and pop
FTST	Test
FXAM	Examine

Data Transfer Instructions

Real Transfers

FLD	Load real
FST	Store real
FSTP	Store real and pop
FXCH	Exchange registers

Integer

FILD	Integer load
FIST	Integer store
FISTP	Integer store and pop

Packed Decimal Transfers

FBLD	Packed decimal (BCD) load
FBSTP	Packed decimal (BCD) store and pop

Arithmetic Instructions

Addition

FADD	Add real
FADDP	Add real and pop
FIADD	Integer add

Subtraction

FSUB	Subtract real
FSUBP	Subtract real and pop
FISUB	Integer subtract
FSUBR	Subtract real reversed
FSUBRP	Subtract real reversed and pop
FISUBR	Integer subtract reversed

Multiplication

FMUL	Multiply real
FMULP	Multiply real and pop
FIMUL	Integer multiply

Division

FDIV	Divide real
FDIVP	Divide real and pop
FIDIV	Integer divide
FDIVR	Divide real reversed
FDIVRP	Divide real reversed and pop
FIDIVR	Integer divide reversed

Other Operations

FSQRT	Square root
FSCALE	Scale
FPREM	Partial remainder
FRNDINT	Round to integer
FEXTRACT	Extract exponent and significand
FABS	Absolute value
FCHS	Change sign

Table 1: The 8087 instruction set grouped by class.

consideration should apply fully to almost any 8088- or 8086-based system that has the 40-pin 8087 socket on the system board. If the system runs PC-DOS (or, equivalently, MS-DOS), then the software support presented in this article should be applicable to any user of Microsoft's Macro Assembler for the 8088/8086 systems.

M8087.MAC

The 8087 watches for ESC (escape) instructions as potential operations for it to work on, while the 8088

CPU ignores them. Therefore it is possible for the assembly-language programmer to use the 8087 by looking up the proper escape-code sequence for each 8087 instruction in a table and inserting the ESC instruction in the program. (For example, an FDIV instruction translates to the hexadecimal sequence "DC F1", which translates to "ESC 26H,CX".) Obviously this tedious and error-prone task is the same as assembling the instructions into machine code by hand.

To avoid those errors and save time, we'll let the user

Text continued on page 350

IN THE FLAT WORLD OF NETWORKING THERE IS A COLUMBUS.



NOVELL.

We Know How You Felt, Columbus!

In 1492 most people were saying the world was flat. They said, "You'll fall off the edge if you go too far." But that didn't stop you Columbus. You went ahead and discovered America.

Today, most people are saying, "file service...is just not feasible."* They're even saying, "operations like record locking are not available."** But that hasn't stopped Novell, either. Because we've gone ahead and discovered, designed, yes... even built and shipped file servers that the less adventurous said couldn't be built. And our file servers are up and running all over America, (not to mention the rest of the world.)

Our Versatile Applied Server Technology (VAST) lets multiple operating systems on multiple types of personal computers share the same disk space and directories simultaneously.

And yes, all you other guys, record locking is available...on the ShareNet/VAST system, anyway.

Discover the vast ShareNet Difference.

The trouble with the "civilized" world of networking offered by our competitors is that they are still thinking FLAT! They're still concentrating on the hardware connection instead of the software that makes

that hardware function. Just like Columbus, Novell is the ONLY company that can offer you a VAST networking difference. We're thinking round, you see.

Does choosing a network have you "on edge"?

Don't fall off the edge! If networking—we mean real local area networking of numerous PC's, running multiple operating systems without modification to "off the shelf" software, having concurrent file sharing, default file locking, extensive data security and more—sounds exciting to you, call us for a demonstration so you can discover your options. ShareNet/VAST will take you out of the "flat" bounded network world and into the boundless universe of networks that work.

Explore Novell's world!

Discover the vast ShareNet difference. You'll find out-of-this-world performance at very down-to-earth prices. ShareNet/VAST is easy to use. All you have to do is call us and we'll set sail on a course that solves your PC networking problems. Get on board with the Columbus of networking. Novell, Inc., 1170 North Industrial Park Drive, Orem, Utah 84057, 801 226-8202 • 800 453-1267

**Novell—making networks work.
Our VAST difference.**

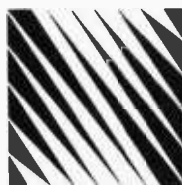

NOVELL

*3Com Corp. in March Systems & Software, pg. 118
**3Com Corp. in March Systems & Software, pg. 119

**HANG ON
TO YOUR HAT,
CHARLIE...**



THE CORONA PC'S™ ARE HERE.



The Corona PC's, desktop and portable, give you everything you've ever wanted in an IBM-compatible PC and more. For a great deal less.

Compatible and more.

The Corona PC is a 16-bit microcomputer based on the 8088 microprocessor, just like the IBM PC. And like the IBM PC, it runs any software that conforms to the IBM standard.

But unlike the IBM PC, the Corona PC comes with 128K of memory. Supports up to 512K on the main board. Includes a 320K floppy drive, a communication port, a printer port and an improved IBM PC keyboard.

Both the desktop and portable Corona PC's include high-resolution monitors and built-in graphics. Higher character definition makes both models easier to read, and our 640 x 325 pixel high-resolution graphics are over 60% better than the

IBM PC. It's a complete system, the standard for microcomputing in the IBM-compatible world.

You can take it with you.

And unlike IBM, we have a portable version.

Its high-resolution, high-contrast 9" display is easy to read. It has all the power and features of our desktop, but lets you take it to the office next door, across the country or just conveniently tuck it onto a corner of your desk.

More expandability.

You may never add a thing to your Corona PC because we've built in so much capability.

But just in case, we've built all the important components into the main system board, leaving the four expansion slots free. And provided an extra large power supply to support any capabilities you may want to add in the future.

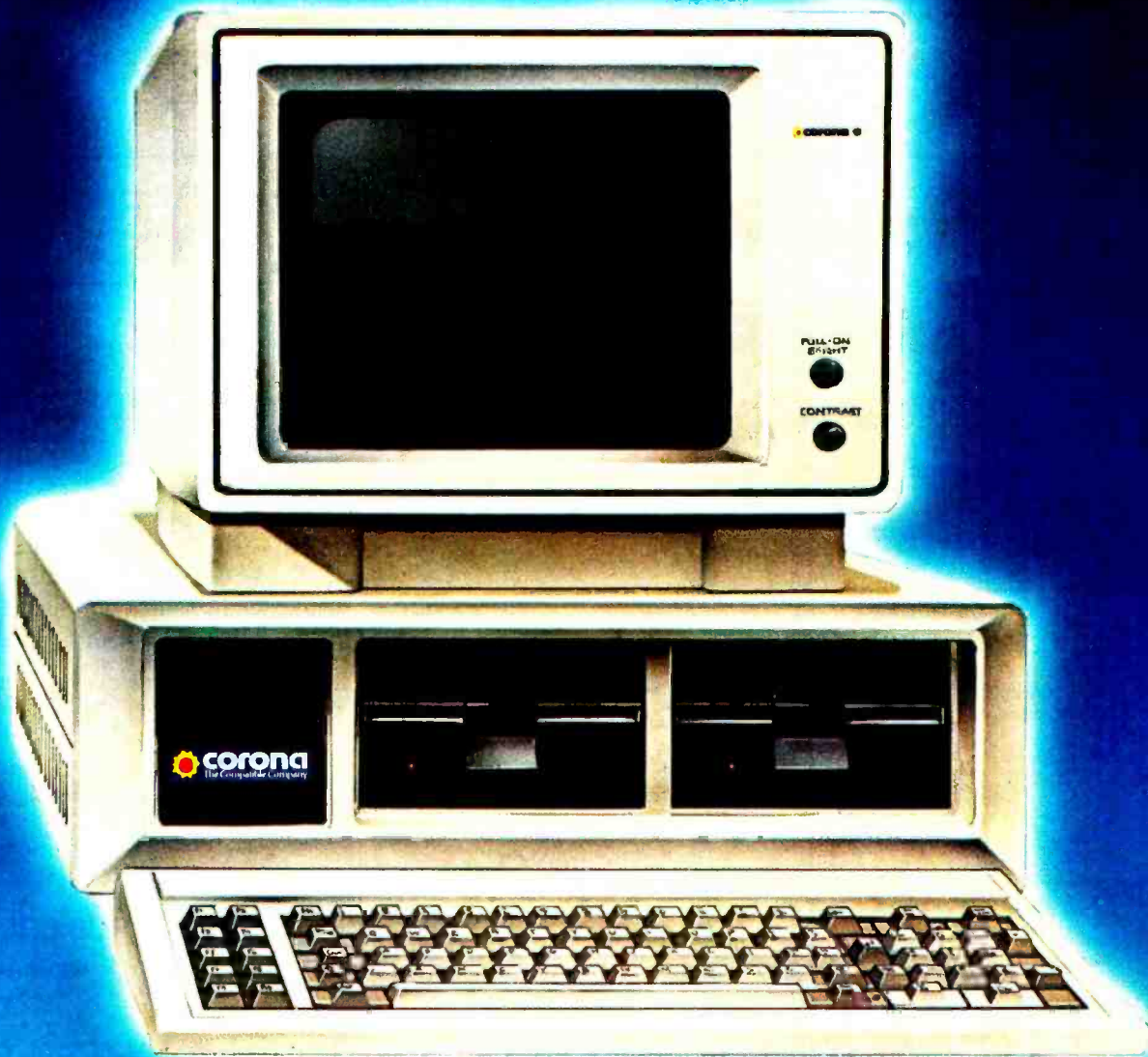

RAM-disk for incredible speed.

Our RAM-disk software lets you treat an area of your computer's memory as if it were a disk drive. So you can copy your programs and data into memory, then watch your work get done faster.

More software.

The Corona PC includes the MS-DOS operating system and comes with GW-BASIC, the MultiMate¹ word processor and the PC Tutor² training course. So you can start being productive immediately.

And you can run Context MBA³, dBASE II⁴, LogiCalc⁵ and LogiQuest⁵, the EasyFamily⁶, Wordstar⁷ and the "Star" family, the SuperWare⁸ series, T.I.M.⁹, the VisiSeries¹⁰ and Perfect Series¹¹ of programs and most other popular software.

And it improves your bottom line.

The Corona Portable PC™ is \$2,545, the desktop

version is \$2,595. Both about a thousand dollars less than the equivalent IBM PC.

For more information, contact Corona Data Systems, 31324 Via Colinas, Westlake Village, CA 91361. (213) 991-1144. Call (800) 621-6746 toll-free.

Or better yet, just grab your hat and head to the nearest Corona PC dealer for a very convincing demonstration.

Circle 116 on Inquiry card.



© Corona Data Systems 1983 1: TM Softword Systems. 2: TM Comprehensive Software Support. 3: TM Context Management Systems. 4: TM Ashton-Tate. 5: TM Software Products International. 6: TM Information Unlimited Software. 7: TM Micropro. 8: TM Sorcim Corp. 9: TM Innovative Software. 10: TM Visicorp. 11: TM Perfect Software Inc.

Come visit us in our
New York showroom.

Computer Channel

Our Speciality: 68000, 6809 CPU, graphic, database, communication



TELEVIDEO, VISUAL, IDS, OKIDATA, EPSON, HOUSTON INSTRUMENT

C.ITOH, TANDON, SWTPC, AMDEK, NEC, IBM, DEC, ESPRIT, QUME, GTCO

COMPUTERS

CROMEMCO

Best Price
Anywhere

CS1D2E 256K RAM, 68000 & Z80 two
5 1/4" floppy disks 4,396

CS1HD5E 512K RAM, 68000 & Z80
20MB hard disk, one 5 1/4"
floppy disk 7,596

WICAT

1 to 12 users, 68000 CPU, 256K to
4.5MB RAM, 10MB to 474MB hard
disk, graphic 9,000 & up

DUAL 68000 CPU, 80MB SMD hard
disk, intelligent I/O, UNIX, relational
database CALL

SWTPC, HELIX, DYNABYTE, TERAK CALL

YOUR OWN PERSONAL ROBOT 2,125

MODEMS

D.C. Hayes Smartmodem
300 baud 230
1200/300 baud 530
*1200B modem & communication
SW 470

USR Auto Link 1200 450

UDS 212 LP 400
212A 595

Novation Smartcat 300 200
Smartcat 300/1200 455
J-Cat 130

SOFTWARE

dBase II Ashton-Tate 489

Redding Grftalk business graphics 400
Async micro to mainframe 100
Alpaca micro to micro 450
Crosstalk Microstuf 160

Accounting software
*Accounting Plus 299
*Legal Timekeeping &
Accounting 699
*Peach pak (GL,AR,AP) 390

TERMINALS

Zenith Z-29 Smart terminal 648
ZT-1 with modem 488

Hazeltine ESPRIT II 588
Esprit III emulate Televideo 950895
Esprit III color terminal 875

Televideo 925 740
970 1,099

Visual 50 625
55 green 725
300 948
550 graphic 2,200

Wyse 100 795

Viewpoint ADDS color terminal CALL

Prices subject to change. American Express, Visa/Mastercard
add 3%. F.O.B. point of shipment. 20% restocking fee for
returned merchandise. Personal checks take 3 weeks to
clear. COD on certified check only. N.Y. residents add sales
tax. Manufacturers' warranty only. International customers,
please confirm price before order. Accept P.O. from Fortune
500, schools and gov't.

*For IBM

PC COMPUTERS

CROMEMCO C-10
Super Pak \$ 1490

Televideo 803 1,995

IBM COMPATIBLE

Z-110 Zenith
Dual drives, 128K RAM,
8/16 bit, color board, 225 x 640
graphics 2,799
with 11MB hard disk 4,699

ZW-110-32 RGB color monitor
ZVM-135 640 x 480 550

Corona
128K RAM, 320K floppy, 640 x 325 graphic,
green monitor ser. & par. port, DOS, GW BASIC,
MultiMate word processing, PC Tutor CALL

Eagle
*128K RAM, two floppy disks, monitor, two ser. &
one par. ports, EagleWriter, EagleCalc, MS-DOS,
and CP/M-86 2,799

Columbia
128K RAM, two floppies, 2 Ser. & 1 par.
ports, software 2,499

IBM PC CALL

Portable Computer
Corona PPC-1 128K RAM, one 320K
floppy, monitor, and serial
port CALL

Columbia, Hyperion CALL

AST, Quadram, LNW cards CALL

PRINTERS

BANANA 50 cps 205

IDS
Microprism 110 cps, 84 x 84 graphic, pin &
friction feed, ser./par. 498

Prism 132 200 cps, 132 col. 1,100
with graphic 1,180
with graphic, color, friction 1,590

Gemini 10 100 cps 345
15 525

Epson FX-80 160 cps 580
Okidata ML 83A 625
84 Par 960
92 520
93 840

MT 180L 160 cps 620
MT 180Z 200 cps 1,393

C.ITOH Prowriter I par 410
8800 two colors 1,050

Letter Quality

Dynax 15 13 cps 520

Brother HR-1 12 cps 785

Silver Reed 699

Transar 130 727

Diablo 620 998

C.ITOH F-10 Starwriter 40 cps 1,295
NEC 7710, 7730 2,250
3550 for IBM 1,850

Qume 11+ 40 cps 1,400

MONITORS

Zenith ZVM-123 12" green 115
ZVM-122 12" Amber 139
ZVM-131 medium resolution 305
*ZVM-135 640 x 480 550
color I 13" 340

Amdak *color II RGB 699
color IV 720 x 400 1,070

NEC 12" green 170
1203 RGB 725

Texan color monitor 330
Amber 149

PLOTTER/DIGITIZER

Houston Instrument DMP-29 1,795
DMP-40 795
DMP-41 & DMP-42 CALL

Amdak XY plotter, 1 pen 665
6 pens 1,095

Sweet-P *Plotter 610
GTCO *graphic analysis package
w/digitizer for IBM 2,500

COMPUTER CHANNEL COMPUTER CHAN

Monthly Special

\$380 MITSUBISHI

8" Double Sided/Double Density
Flexible disk drive
Qume & Shugart
Compatible

M2894-63 1.2MB drive 380

Two M2894 drives, cabinet with power supply
& fan (unassembled) 1,099

8" dual M2894 drives subsystem
(assembled) 1,130

Technical manual 25

Dual drives signal cable 50

Slimline bare drive 8" 410
(compatible w/Cromemco 64FDC)

Dealers Welcome

PUTER CHANNEL COMPUTER CHANN

For information CALL (212) 937-6363
To order CALL 1-800-331-3341

Computer Channel TELEX:
21-55 44th Road 429418
Long Island City, NY 11101 CSTNY

```

endif
ifidn <#P_ST>,<st(i)>
  REG = 0
endif
ifidn <#P_ST>,<st(1)>
  REG = 0
endif
endif

*****
**
** CHK_CONC - Simple macro that will automatically insert
** WAIT statements AFTER every 8087 instruction
** which accesses CPU main memory. If variable
** "AUTOSYNC" <> 0, then these WAITS will be
** inserted (providing no concurrency but relieving
** the programmer from worrying about synchronizing
** data references. If the user program sets
** AUTOSYNC to a zero value, then no WAITS
** are inserted after the instructions and it is
** the user's responsibility to insure synch-
** ronization.
**
** *****
CHK_CONC macro
  if AUTOSYNC
    WAIT ; Automatic synchronization
  endif
endif

*****
**
** CHOOSE_4 - Determine which of four parameters (XXX1 to XXX4)
** should be used in ESC sequence, depending on P1
** and P2 values. P1 and P2 are parameters passed
** by user in macro call. XXX1 to XXX4 are macro-
** dependent parameters tacked on to the call to
** CHOOSE_4 by the specific 8087 macro called by the
** user code.
**
** *****
CHOOSE_4 macro P1,P2,XXX1,XXX2,XXX3,XXX4
  ; Initialize variables
  ZERO = 0
  NOTZERO = 0
  REG = 0
  ;
  ; If user passed no parameters, (P1 and P2 are "blank") then
  ; issue a call to ESC_REG macro to set up proper ESC sequence.
  ; An arithmetic instruction with no operands is identical to the
  ; same instruction with the operand form "ST(1),ST".
  ; Example : "FDIV" - Divides second element on stack by first and
  ; places result in second element on stack.
  ;
  ifb <P1>
    REG = 1
    ESC_REG XXX1,REG
  else
    ;
  ;

```

```

; Check to see if first parameter (P1) passed by user is "ST".
; If yes, indicates that second parameter (P2) is of form "ST(i)"
; so use CHECK_ST macro to determine 'i'. Then call ESC_REG macro
; to issue ESC sequence
; Example : "FADD ST,ST(4)" - Adds register four (fifth element on
; 8087 stack) to top element and leaves result on top
; of stack.
;
; ifidn <P1>,<ST>
; CHECK_ST P2
; ZERO = REG + 1
; if ZERO
;   REG = 1
; endif
; ESC_REG XXX2,REG
; else
;   ifidn <P1>,<st>
;     CHECK_ST P2
;     ZERO = REG + 1
;   if ZERO
;     REG = 1
;   endif
;   ESC_REG XXX2,REG
; else
;   ; See if P1 is of form "ST(i)". CHECK_ST returns with REG = -1
;   ; if not, else REG = i (i from 0 to 7). If of ST(i) form, assume
;   ; P2 is ST (ie. operands are "ST(i),ST". Use ESC_REG for ESC
;   ; sequence
;   ; Example : "FSUB ST(3),ST" - Subtract top of stack from register
;   ; three (the fourth element down the stack) and leave
;   ; result in register 3.
;   ;
;   ; CHECK ST P1
;   ; NOTZERO = REG + 1
;   ; if NOTZERO
;   ;   ESC_REG XXX1,REG
;   ; else
;   ;   ; See if P1 indicates operation is "SHORT" real type. If so,
;   ;   ; then P2 is address of source/destination and XXX3 sets up
;   ;   ; SHORT version of operation requested.
;   ;   ; Example : "FMUL SHORT VECTOR[SI]" - Multiply 32 bit number
;   ;   ; found in memory at VECTOR offset from DS:SI address
;   ;   ; by top of 8087 stack and leave result on top of stack
;   ;
;   ; ifidn <P1>,<SHORT>
;   ;   ESC XXX3,P2
;   ;   CHK_CONC ; Insert non-concurrent WAIT?
;   ; else
;   ;   ifidn <P1>,<short>
;   ;     ESC XXX3,P2
;   ;     CHK_CONC ; Insert non-concurrent WAIT?
;   ;   else
;   ;     ; See if P1 indicates a "LONG" real type. If so, P2 is
;   ;     ; source/destination address and XXX4 is LONG opcode.
;   ;     ; Example : "FDIV LONG [BP].ID_NUMB" - Divide top of stack
;   ;     ; by 64 bit number found at SS:BP + ID_NUMB
;   ;     ; in memory. Leave result on top of 8087 stack
;   ;
;   ;   ifidn <P1>,<LONG>
;   ;     ESC XXX4,P2
;   ;     CHK_CONC ; Insert non-concurrent WAIT?
;   ;   else
;   ;     ifidn <P1>,<long>
;   ;       ESC XXX4,P2
;   ;       CHK_CONC ; Insert non-concurrent WAIT?
;   ;     else

```

stair war

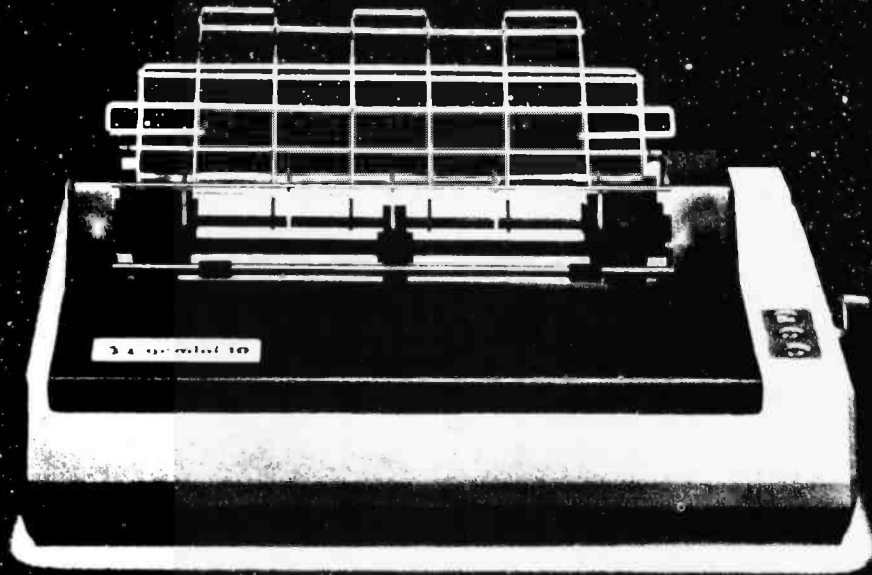

AN ASTRONOMICAL VALUE AND

THE LOWEST PRICES

IN THE GALAXY ON

stair 
PRINTERS

CALL: (303) 279-2848 or (800) 525-7877



THE COMPUTER LINE, INC.
GOLDEN, COLORADO

Offer void outside the Milky Way

```

endm
FCLEX macro P1,P2 ; Clear exceptions - No operands
      WAIT ; Synchronization cmd
      FNCLX ;
endm
FCOM macro P1,P2 ; Compare real - //source
      WAIT ; //ST(i)/short-real/long-real
      CHOOSE_4 P1,P2,02H,,02H,22H ; Synchronization cmd
endm
FCOMP macro P1,P2 ; Compare real and pop - //source
      WAIT ; //ST(i)/short-real/long-real
      CHOOSE_4 P1,P2,03H,,03H,23H ; Synchronization cmd
endm
FCOMPP macro P1,P2 ; Compare real and pop twice - No operands
      WAIT ; Synchronization cmd
      ESC 33H,CX ;
endm
FDECSTP macro P1,P2 ; Decrement stack pointer - No operands
      WAIT ; Synchronization cmd
      ESC 0EH,SI ;
endm
FDISI macro P1,P2 ; Disable interrupts - No operands
      WAIT ; Synchronization cmd
      FNDISI ;
endm
FDIV macro P1,P2 ; Divide real - //source/destination,source
      ifb <P1> ; //ST(i),ST/short-real/long-real
      else ; If no parameters, classical stack - discard operands
          FDIVP ST(i),ST
      endif
      WAIT ; Synchronization cmd
      CHOOSE_4 P1,P2,26H,06H,06H,26H ;
endm
FDIVP macro P1,P2 ; Divide real and pop - destination,source
      WAIT ; ST(i),ST
      CHOOSE_4 P1,,36H ; Synchronization cmd
endm
FDIVR macro P1,P2 ; Divide real reversed - //source/destination,source
      ifb <P1> ; //ST,ST(i)/ST(i),ST/short-real/long-real
      else ; If no parameters, classical stack - discard operands
          FDIVRP ST(i),ST
      endif
      WAIT ; Synchronization cmd
      CHOOSE_4 P1,P2,27H,07H,07H,27H ;
endm
FDIVRF macro P1,P2 ; Divide real reversed and pop - destination,source
      WAIT ; ST(i),ST
      CHOOSE_4 P1,,37H ; Synchronization cmd
endm
FENI macro P1,P2 ; Enable interrupts - No operands
      WAIT ; Synchronization cmd
      FNENI ;
endm
FFREE macro P1 ; Free register - destination
      WAIT ; ST(i)
      CHOOSE_4 P1,,2BH ; Synchronization cmd
endm
FIADD macro P1,P2 ; Integer add - source
      WAIT ; word-integer/short-integer
      INT_SIZE P1,P2,10H,30H ; Synchronization cmd
endm
FICOM macro P1,P2 ; Integer compare - source
      WAIT ; word-integer/short-integer
      INT_SIZE P1,P2,12H,32H ; Synchronization cmd
endm
FICOMP macro P1,P2 ; Integer compare and pop
      WAIT ; word-integer/short-integer
      INT_SIZE P1,P2,13H,33H ; Synchronization cmd
endm
FIDIV macro P1,P2 ; Integer divide - source
      WAIT ; word-integer/short-integer
      INT_SIZE P1,P2,16H,36H ; Synchronization cmd
endm
FIDIVR macro P1,P2 ; Integer divide reversed - source
      WAIT ; word-integer/short-integer
      INT_SIZE P1,P2,17H,37H ; Synchronization cmd
endm
FILD macro P1,P2 ; Integer load - source
      WAIT ; word-integer/short-integer
      INT_SIZE P1,P2,18H,38H,3DH ; Synchronization cmd
endm
FIMUL macro P1,P2 ; Integer multiply - source
      WAIT ; word-integer/short-integer
      INT_SIZE P1,P2,11H,31H ; Synchronization cmd
endm
FINCSTP macro P1,P2 ; Increment stack pointer - No operands
      WAIT ; Synchronization cmd
      ESC 0EH,DI ;
endm
FINIT macro P1,P2 ; Initialize processor - No operands
      WAIT ; Synchronization cmd
      FNINIT ;
endm
FIST macro P1,P2 ; Integer store - destination
      WAIT ; word-integer/short-integer
      INT_SIZE P1,P2,14H,34H ; Synchronization cmd
endm
FISTP macro P1,P2 ; Integer store and pop - destination
      WAIT ; word-integer/short-integer
      INT_SIZE P1,P2,15H,35H ; Synchronization cmd
endm

```

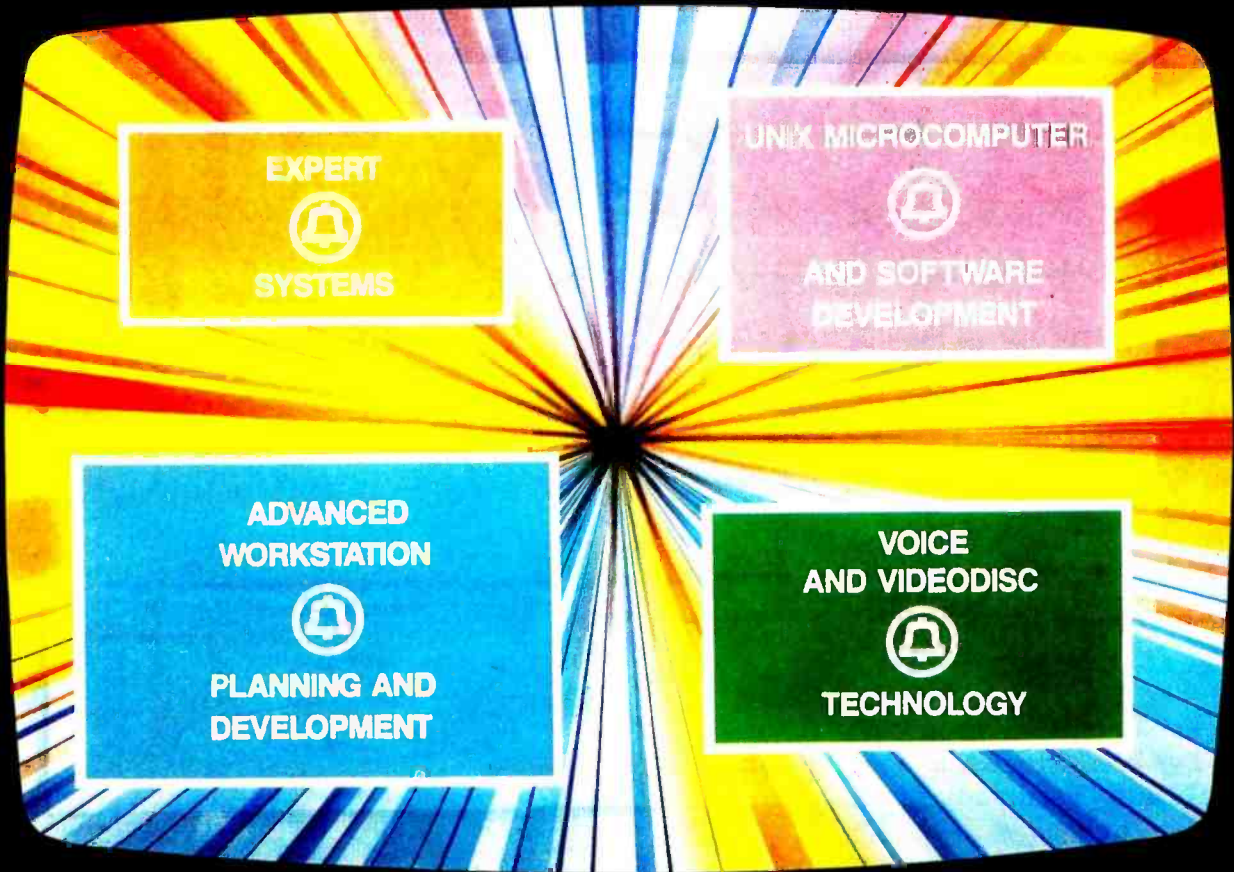
REACH OUT AND TOUCH TOMORROW

Bell Laboratories is moving in new directions to develop sophisticated UNIX™ applications for microcomputers. Here, at the home of UNIX, we are applying advanced technology to every facet of information systems.

One of our newest developments is ARIEL, an interactive information retrieval system, the first to bring audio, text and video together in a centrally controlled network. ARIEL is inviting visitors at Disney's EPCOT Center to 'reach out and touch me' to see and hear about attractions in the park, make reservations for dinner and even speak to guides over a two-way video system.

And ARIEL is just the beginning...

The microcomputer is going everywhere and we are going everywhere with it.

To assist us in developing unique applications for tomorrow's microcomputers, we need talented software and computer engineers who are in close touch with one or more of the expertises displayed above and who have an MS or PhD degree or a BS degree with at least five or more years of highly relevant experience.

Successful candidates will have the opportunity to work creatively to:

- Develop software for UNIX-based microprocessors
- Develop software for advanced display systems

- Develop voice and text applications for intelligent workstations in the UNIX environment
- Identify and develop management decision support software for various vertical applications
- Plan and develop videodisc-based information retrieval systems
- Develop knowledge-based, expert systems using artificial intelligence techniques.

At Bell Labs, you will have a wide spectrum of technical resources readily available to you. Processor, software and communications capabilities will be at your finger tips. You will work with some of the best minds in your field in an atmosphere that fosters free exchange of ideas.

Openings are located at our Laboratories in New Jersey.

If you have the required credentials and are interested in joining us in shaping the future of microcomputers, please send your resume detailing education and experience to:
 Director, Technical Employment,
 Bell Laboratories, Dept. 303/45 31/83,
 150 John F. Kennedy Parkway,
 Short Hills, New Jersey 07078.

An equal opportunity employer.

Bell Laboratories

Get everything

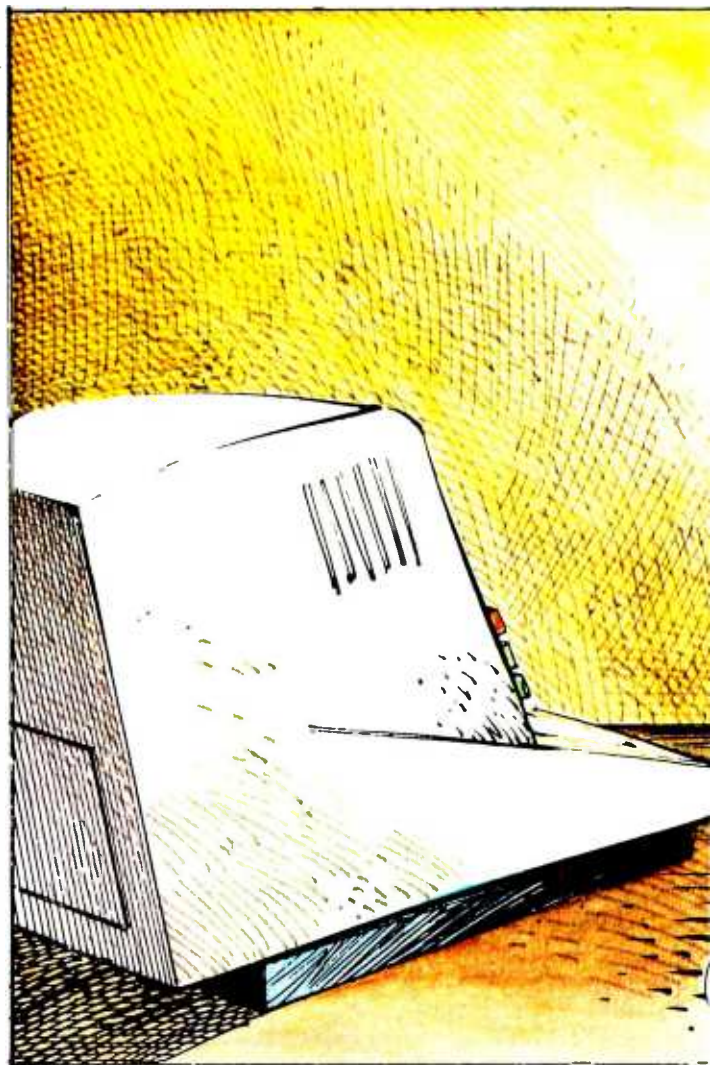

I'm a pretty smart guy.

I've been Office Manager for only six weeks and I've already scored an impressive coup:

I talked the old man into investing in some office help that's already paid for itself.

And now we're getting everything done by Friday! Every single day of the week.

That may sound confusing but it really isn't. Because Friday! is the revolutionary new electronic file handling system from Ashton-Tate, the people who invented dBASE II™

Friday! runs on your microcomputer and it's made for people like you and me, people who know their jobs but who don't know much about computers.

I won't go into great technical detail about Friday! because there isn't any. I just follow the English-language instructions on the screen, push a few buttons and—Zap!—I get the job done. With incredible speed because we've turned our paper files into much more efficient "electronic files."

So whatever I need to know, I can find it in seconds.

Sales by product, salesman and territory since the first of the year.

Time billing for work in progress last month.

A quick report on our accounts payable.

Or a custom report that the old man can take to a Board of Directors' meeting. (Friday! and I whipped one out last week and

he said it was the best he'd seen since the company opened its doors.)

Very simply—and with blazing speed—Friday! handles just about everything that needs handling around the office.

It's terrific for inventory and invoices and paychecks and input screens and plain or fancy reports. It works with dBASE II and 1-2-3¹ and Wordstar² files.

And wait until you see the way it handles mailing lists and labels—it's worth the \$295 price for that alone!

done by Friday!™

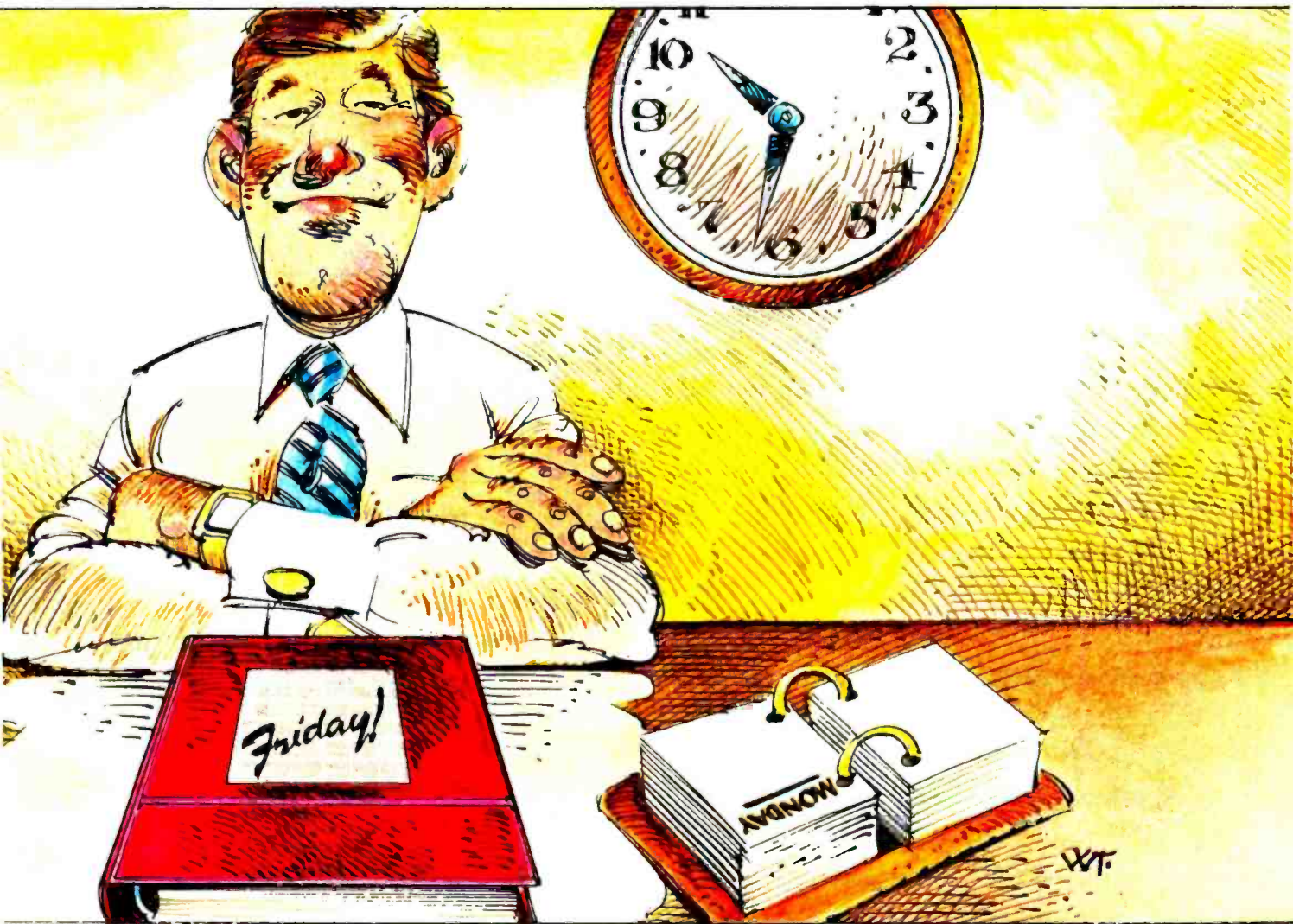

Well, with Friday! on board, everything's running so smoothly these days, I now have time to contemplate my next move up the corporate ladder.

If, that is, Dad has cleared off the next rung for me.

For the name and location of the Friday! dealer nearest you, contact Ashton-Tate, 10150 W. Jefferson Blvd., Culver City, CA 90230, (213) 204-5570.

Or better yet, just call today and start getting everything done by Friday!

ASHTON-TATE 

©Ashton-Tate 1983.
Friday! runs under CP/M³⁻⁸⁰, CP/M-86, PC-DOS¹ and MS-DOS⁵
Friday! and dBASE II are trademarks of Ashton-Tate.
1-TM Lotus Corp. 2-TM Micropro. 3-TM Digital Research.
4-TM IBM Corp. 5-TM Microsoft.



The Micromint MPX-16 Microcomputer System.

As featured on the cover of "BYTE" magazine, November 1982.
Also featured in Ciarcia's Circuit Cellar, November, December 1982 & January 1983.

These are all the tools you'll need to build the world's most powerful single board microcomputer.

The Micromint MPX-16. Put one together tonight.

Once assembled, the most useful tool will be your own imagination. The possibilities are limitless. Micromint will help you tailor the MPX-16 system to your particular needs and budget. Purchase the MPX-16 as a bare pc board, as a semi-kit with all the IC sockets, I/O connectors and discreet components wave soldered to the pc board, or as an assembled and tested unit.

- Directly boots CP/M-86 or MS-DOS.*
- Runs all CP/M-86 or MS-DOS * applications programs.

On board features.

- IBM PC bus compatible with 9 expansion slots.
- Intel 8088 16-bit microprocessor.
- Optional Intel 8087 math coprocessor.
- 256K bytes on board memory.
- Up to one megabyte of system memory.
- Up to 64K bytes of system ROM/EPROM.
- Two RS-232C serial I/O ports.
- Three parallel I/O ports.
- Floppy disk controller for 5 1/4" or 8" single or double density disk drives.
- Four independent DMA channels.
- Sixteen levels of vectored interrupts.

* Available Soon.

Circle 483 on inquiry card.

Micromint MPX-16

The System with the Winning Combination.

IBM PC is a trademark of International Business Machines, Inc.. CP/M-86 is a trademark of Digital Research, Inc..

To get the MPX-16 up and running only requires one disk drive, power supply and serial terminal.

- MPX-16 single board computer assembled, tested and burned in with 64K bytes of RAM, CP/M-86 or MS-DOS operating system * \$1,895.00
 - MPX-16 with 256K bytes of RAM \$2,135.00
 - MPX-16 Semi-Kit (wave soldered pc board) less IC's \$595.00
 - Complete kit of IC's burned in and tested with 64K bytes of RAM \$595.00
 - With 256K bytes of RAM \$800.00
 - MPX-16 Unpopulated (bare) pc board, silk screened and solder masked \$300.00
 - CP/M-86 Operating System on 5 1/4" or 8" diskette. . . \$200.00
 - MPX-16 Switching Power Supply including power supply harness \$300.00
 - MPX-16 Technical Reference and User's Manual \$50.00
- Call for current pricing on serial terminals, floppy disk drives, metal enclosures, hard disk systems, etc.

To Order: Call Toll Free
1-800-645-3479
In N.Y. 1-516-374-6793

MICROMINT INC.
561 Willow Avenue
Cedarhurst, NY 11516



MS-DOS is a trademark of Microsoft Corp

```

macro P1,P2 ; Multiply real - //source/destination,source
//ST(i),ST(i),ST(i)/short-real/long-real
ifb <P1> ; If no parameters, classical stack - discard operands
FMULP ST(1),ST
else
WAIT ; Synchronization cmd
CHOOSE_4 P1,P2,21H,01H,01H,21H
endif
endm

macro P1,P2 ; Multiply real and pop - destination,source
//ST(i),ST(i),ST
WAIT ; Synchronization cmd
CHOOSE_4 P1,,31H
endm

macro P1,P2 ; Clear exceptions - No wait FCLEX
ESC 1CH,DX
endm

macro P1,P2 ; Disable interrupts - No wait FDISI
ESC 1CH,CX
endm

macro P1,P2 ; Enable interrupts - No wait FENI
ESC 1CH,AX
endm

macro P1,P2 ; Initialize processor - No wait FINIT
ESC 1CH,BX
endm

macro P1,P2 ; No operation - No operands
WAIT
ESC 0AH,AX
endm

macro P1,P2 ; Save state - destination (No wait FSAVE)
ESC 2EH,P1
endm

macro P1,P2 ; Store control word - destination (No wait FSTCW)
ESC 0FH,P1
endm

macro P1,P2 ; Store environment - destination (No wait FSTENV)
ESC 0EH,P1
endm

macro P1,P2 ; Store status word - destination (No wait FSTSW)
ESC 2FH,P1
endm

macro P1,P2 ; Partial arctangent - No operands
WAIT
ESC 0EH,BX
endm

macro P1,P2 ; Partial remainder - No operands
WAIT
ESC 0FH,AX
endm

```

```

macro P1,P2 ; Integer subtract - source
word-integer/short-integer
WAIT ; Synchronization cmd
INT_SIZE P1,P2,14H,34H
endm

macro P1,P2 ; Integer subtract reversed - source
word-integer/short-integer
WAIT ; Synchronization cmd
INT_SIZE P1,P2,15H,35H
endm

macro P1,P2 ; Load real - source
//ST(i)/short-real/long-real/temp-real
WAIT ; Synchronization cmd
CHOOSE_4 P1,P2,0BH,1DH,0BH,2BH ; IDH INDICATES TEMPORARY REAL !!
endm

macro P1 ; Load control word - source
2-bytes
WAIT ; Synchronization cmd
ESC 0DH,P1
endm

macro P1 ; Load environment - source
14-bytes
WAIT ; Synchronization cmd
ESC 0CH,P1
endm

macro P1 ; Load log 2 (base 10) - No operands
WAIT
ESC 0DH,SP
endm

macro P1 ; Load log 2 (base e) - No operands
WAIT
ESC 0DH,BP
endm

macro P1 ; Load log e (base 2) - No operands
WAIT
ESC 0DH,DX
endm

macro P1 ; Load leg 10 (base 2) - No operands
WAIT
ESC 0DH,CX
endm

macro P1 ; Load pi - No operands
WAIT
ESC 0DH,BX
endm

macro P1 ; Load +0.0 - No operands
WAIT
ESC 0DH,S1
endm

macro P1 ; Load +1.0 - No operands
WAIT
ESC 0DH,AX
endm

```



NEW FOR APPLE II AND IIe

WILDCARD™

MAKES BACK-UP COPIES OF PROTECTED SOFTWARE QUICKLY, EASILY, WITH JUST A PUSH OF A BUTTON.

New software locking schemes have rendered even the latest generation of copy programs virtually unusable. Locksmith™, Nibbles Away™ and other "Nibble copiers" require complicated parameter settings, much patience and great effort to use. More often than not, the results are disappointing. WILDCARD is different. Rather than copying disks track by track, WILDCARD ignores the disk and any copy protection encrypted on it. Instead, WILDCARD takes a snapshot of memory in your Apple® II.

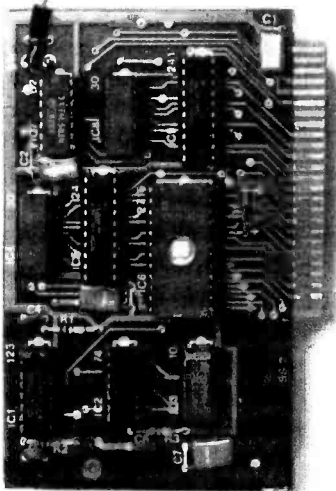
Now you can make back-up copies of protected software with the push of a button.



FEATURES

- Hardware copying device... push button operation.
- Copies 48K memory resident software, most 64K software.
- No programming experience or parameters necessary.
- Backs up DOS 3.2 and DOS 3.3 disks.
- Creates DOS 3.3 unprotected and autobooting disks.
- WILDCARD lives in any slot. Undetectable by software.
- Produces autobooting disk in 2 minutes.
- Copies are DOS 3.3 compatible.
- Copies become accessible for alterations.
- Simple, easy-to-use software included.

WILDCARD Utility Disk 1 also included, featuring:

- Automatic program compression and BRUN file maker.
- Multiple programs can be placed on the same disk.
- Recreates basic files to load and save.
- Files can be placed on a hard disk...and more.

WILDCARD \$139.95

Order direct from East Side Software Co., 344 E. 63 St., Suite 14-A, New York City 10021, 212-355-2860. Please include \$3.00 for shipping and handling. Orders outside continental U.S. please add \$10.00 for shipping and handling. Mail and phone orders may be charged to MasterCard and VISA. N.Y. State residents add sales tax. Dealer inquiries welcome.

IMPORTANT NOTICE: The WILDCARD is offered for the purpose of enabling you to make archival copies only. Under the Copyright Law you, as the owner of a copy of a computer program, are entitled to make a new copy for archival purposes only and the WILDCARD will enable you to do so. The WILDCARD is offered for no other purpose and you are not permitted to utilize it for any other use, other than that specified.

Apple and the Apple logo are registered trademarks of Apple Computer, Inc.—CP/M—trademark of Digital Research, Inc. Locksmith—trademark of Omega Microwave, Inc. Nibbles Away—trademark of Computer: applications.

Software is not copy protected. System requirements: Apple II Plus with 64K and DOS 3.3 or Apple IIe. Franklin Ace also supported.

Wildcard does not operate with CP/M or other microprocessor based software.

Circle 155 on inquiry card.

Turbo-Micro Series 8000 MINI-POWER MICRO-PRICE

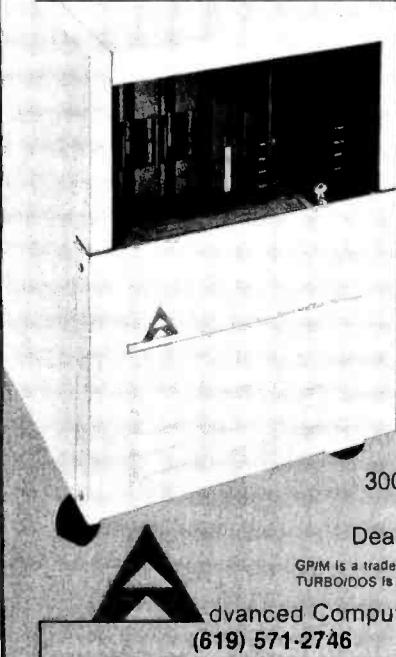

- Up to 30 independent users.
- Powerful Turbo-Dos™ operating system. Total CP/M compatibility.
- Modular S-100 Bus structure. Easily upgradeable.
- Master/slave networking. 8 or 16 bit processors.

Available for up to
300 M Byte Hard Disk.
Prices from \$5,800.
Dealer inquiries invited.

CP/M is a trademark of Digital Research.
TURBODOS is a trademark of Software 2000, Inc.

Advanced Computer Technology, Inc.
(619) 571-2746

freely intermix standard 8088 CPU and 8087 mnemonics in assembly-language programs and then let the macro assembler take care of correctly converting the 8087 instructions into the proper escape codes.

The support package, named M8087.MAC (referred to throughout this article as M8087), uses Intel's mnemonic names for the 8087 instruction set listed in table 1. Because only 8087 instructions begin with the letter "F," it is easy to skim through an assembly-language listing and pick out the appropriate instructions.

The software support package M8087 requires the use of MASM, part of the IBM Macro Assembler package, and at least 96K bytes of RAM (random-access read/write memory). This file of 83 macros presented in listing 1 allows full and easy access to the entire 8087 instruction set at a level equivalent to assembly-language programming.

M8087 is intended to be placed in a separate file (I named mine M8087.MAC and placed it on the disk that contains the macro assembler). The complete package can then be used simply by placing the statement "INCLUDE M8087.MAC" (or some variation such as "INCLUDE A:M8087.MAC", etc.) in the assembly-language program somewhere near its start. This instruction causes the assembler to go to the appropriate disk drive, locate the file M8087.MAC, and read it into the program.

Once M8087 resides on the MASM disk, the single INCLUDE statement provides access to these 8087 mnemonics from any number of programs. Any valid 8087 mnemonic instruction will automatically be expanded into the correct escape sequence at assembly time.

If you look through listing 1, you will notice five long and involved macros at the start (ESC_REG, CHECK_ST, CHK_CONC, CHOOSE_4, and INT_SIZE) followed by 77 short macros, one for each Intel 8087 instruction mnemonic. The first five macros are all nested macros (defined and/or invoked within other macros) called by some of the 77 instruction macros. In fact, ESC_REG, CHECK_ST, and CHK_CONC are nested two levels down because they are invoked by the CHOOSE_4 and INT_SIZE nested macros.

Let's first look at the 77 instruction macros. A careful analysis of the 8087 instruction set and its machine-language op codes leads to a division of the instructions into four types that I call "directly translated," "non-waiting," "integer operations," and "variety."

Directly Translated Instructions

These instructions have only one form of call and include all instructions without operands or with only one type of operand. For example, the FINIT instruction has only a single form translatable into only one valid machine-language sequence, namely "DB E3" (hexadecimal). (For a full list of all the 8087 op codes, see appendix A of Intel's *Numerics Supplement to the 8086 Family User's Guide*.)

The macro for a directly translated instruction can immediately issue the appropriate ESC sequence for the macro invocation because the form is known in advance.

RadioShack TRS-80's Full Line

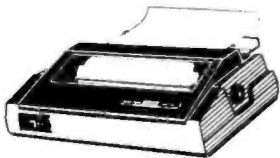

YOU CAN SAVE money when you buy Radio Shack TRS-80 Computers from **Pan American Electronics**. Pan American Electronics went into business in 1976 and led the way in bringing consumers original Radio Shack TRS-80 Computers at reduced prices. **NO** other company has done it longer. **NO** other company has done it better and **NO** other company sells them for less.

Pan American Electronics

TOLL FREE NUMBER 800/531-7466

1117 Conway Avenue • Department B
Mission, Texas 78572
Phone: 512/581-2766
Telex Number 767339

TM — Trademark of Tandy Corporation

Keep your bottom line on the up and up and up.

The future never comes with any guarantees.

But there is a way to improve tomorrow's business performance today.

It's a microcomputer program called the Bottom Line Strategist.™

The future is now.

With the Strategist and your microcomputer, you can explore *alternative* business decisions and get answers to the questions common to any business focused on growth:

How much money are we risking? Will the business be profitable? When? Is that soon enough? Can we improve this by changing the price? What's the

impact of our assumptions on net worth, cash flow, market penetration and growth?

The Strategist uses seven sophisticated econometric models originally developed for companies on the Fortune 500 list.

But it's pre-programmed, so all you do is enter your current business assumptions, then sit back and watch the dynamics of your future unfold graphically.

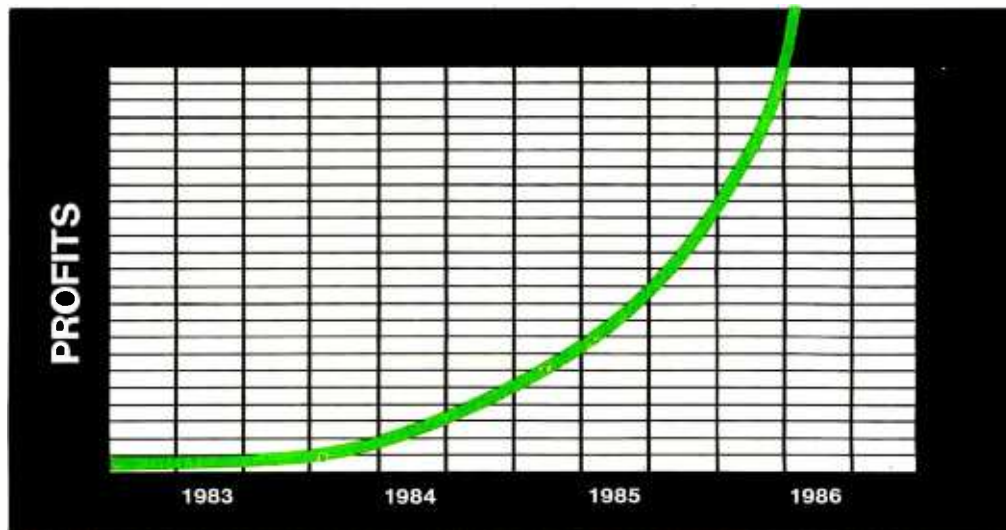

The Strategist plots (and tabulates) your marketing and sales projections; anticipated cash flows; break-even point; Net Present Value; and more—a total of 11 production, financial and marketing forecasts.

If any area looks interesting, the unique "zoom" takes you in for a closer look at the picture. And if you don't like what you see, do it all over again.

Instantly. Without any programming.

And do it as often as you need to get the results that you want.

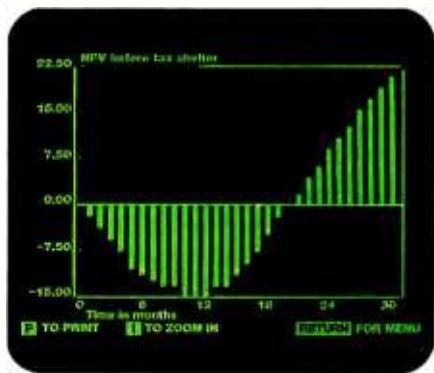

Tomorrow's answers today.

The Strategist is a unique short-cut to experience, without the hard knocks.

You can refine your pricing policies. Optimize your cash flows. And maximize your profits while minimizing your risks.

In today's business climate, how much is that worth? The Bottom Line Strategist is \$400.

Our no risk offer.

You can check out the Bottom Line Strategist with no financial risk.

Drop by a dealer showroom and run through a hands-on demonstration. Then take home a package and use it for 30 days. It runs on 8-bit and 16-bit microcomputers (IBM PC, Apple II, CP/M, etc.) If you don't like it, return it and you'll get your money back.

For the name of your nearest dealer, contact Ashton-Tate at 10150 West Jefferson Boulevard, Culver City, CA 90230.

Better yet, call (213) 204-5570 today. Because if time is money, the Bottom Line Strategist is money in the bank.

The Bottom Line Strategist™

ASHTON·TATE ■

Circle 37 on inquiry card.

CP/M is a trademark of Digital Research. ©Ashton-Tate 1983.

DataVu™

A Complete Information Management Facility

Here's What They're Saying About Us

"Thank you!! for DATAVU. After spending hundreds of dollars and hours on DBASE 11, Condor and other DBASE systems, with little or no results in applying them in my business I feel that DATAVU is a SUPER DBASE system that can be implemented by any small business."

James E. Proctor

President, Valcom, Inc., White River, VT

"This relational data base system in perhaps the finest value in software today. You include an easy-to-use screen formatting utility and a powerful forms processor that truly make setting up a data base a task easy enough for any user."

Scott M. Baker

Assistant Manager, Heathkit, Jericho, NY

"... how can it be good? Take it from a programmer, it beats those Data Base Manager Systems that are priced over \$500 (no need to mention names)."

Ernie Johnson

Stanford Software System, Minitou Springs, CO

After experimenting with and using 10 to 20 microprocessor based databases over the last few years, I have finally found the most powerful and cost-effective tool available to the micro-computer user.

Tom Potter

Roseville Computer Store Roseville, Michigan

```

PATIENT REGISTRATION RECORD
Account Number: ..... Balance 30-01:  .00
Last Name: ..... Balance 00-:  .00

Family Members:
Code   First/Middle Name
-----
1
2
3
4

Address: ..... State:  .. Zip:  ....
City: .....

Phone (01): ..... Date Registered: .....

Search for Account Number: .....
Search for Home Phone:  ..
    
```

Automatic Screen Design (ASD): This feature permits you to specify the design of a form (which may be multi-page) that you wish to use for data entry and data viewing. You simply layout a screen mask and within seconds, without any programming, a data entry program can be generated.

```

MEDICAL OFFICE BILLING SYSTEM
-----
1 Update/View Procedure Code
2 Update/View Patient Registration
3 Post Payments
4 Post Daily Transactions
5 Post Age Balances
6 Print Procedure Codes
7 Print Patient Registration List and Age Balances
8 Print Daily/Monthly Transaction List
9 Print Monthly Summary of Account Balances
10 Print Billing Statements

Press RETURN to exit
OPTION (1-10):
    
```

Automatic Menu Generation: This feature permits you to design your own menus in which each option in the menu may invoke an executable program or a batch file. You simply layout the menu pages, and within seconds, without any programming, your menu program can be generated. This allows you to construct user-friendly menu-driven packages.

```

select account name balance where balance > 0
1 1001:Disk, Floppy F. : 25.00
2 1003:Printer, Dot M. : 12.00

Total number of records read: 2

select service fee from practice
1 Office Visit : 20.00
2 Physical : 25.00
3 X-Ray : 45.00
4 Consultation : 20.00
5 Therapeutic Injection : 60.00
6 Urinalysis : 10.00
7 Tocol Culture : 25.00
8 Hand Feet : 25.00
9 Stool C & S : 25.00
10 Office Surgery : 45.00

Total number of records read: 10
    
```

Relational Data Base Management: Having established data base(s) through use of the ASD feature, you may use the Relational Data Base Management feature to manipulate and retrieve these data. This feature supplies 12 commands and four utility programs to support activities like Select, Sort, Index, Join, Reformat, and so on.

See DataVu™ at your local software dealer. We also have a demonstration system up and running. You can dial in and try most of the DataVu™ features. Call us for more information.

Thinkers Soft, Inc.

P.O. Box 221

Garden City, NY 11530

(516) 294-8104

```

MONTHLY SUMMARY REPORT -- ACCOUNT BALANCE
-----
ACCOUNT NAME (00+) (30-01) (0-30) BAL. DUE
1001 Disk, Floppy F. 25.00 .00 175.00 200.00
1002 Terminal, Dumb. D. 60.00 .00 20.00 40.00
1003 Printer, Dot M. 100.00 .00 85.00 15.00
1004 Micro, Graphics G. .00 .00 40.00 40.00
1005 Modem, Dial D. .00 .00 88.00 88.00

TOTALS 85.00 .00 353.00 428.00
    
```

Report Generation: Reports generated from your data base(s) that become routine and have enduring value may be specified by you in detailed format to the Report Generation feature. It is designed to retrieve information from the data base with simple statements and perform arithmetic operations.

All This. . .

for only

\$250* complete

Available for IBM PC, CP/M®-80: Osborne, Northstar, Micro Decision, Kaypro, Superbrain, Heath 89/Z100, Televideo, NEC, Sanyo, Xerox, Apple II, and 8" SSSD disk. CP/M®-86 available soon.

CP/M is a registered TM of Digital Research, Inc.

* If you want to impress your boss, or your friends, we'll gladly charge you \$700. for this software package.

This instruction type accounts for half of the 8087 instruction set or a total of 38 macros.

Nonwaiting Instructions

The *nonwaiting instructions* are a set of eight mnemonics that Intel defined to help prevent deadlocking the 8087 under special conditions. Notice from listing 1 that, in most of the 77 instruction macros, the first line of the macro definition is a WAIT mnemonic. This is interpreted by the assembler as the normal 8088 WAIT instruction and is assembled as such. This causes the 8088 CPU to wait on the 8087 to finish any current task before beginning the next operation. (When an 8087 and an 8088 are correctly interconnected, the BUSY pin of the 8087 NDP is tied to the WAIT pin of the 8088 CPU. The 8088 WAIT instruction, when executed, waits for the signal on the TEST pin to go low. Because the 8087 holds the BUSY line high while it is executing an instruction, a WAIT instruction executed immediately before an 8087 instruction ensures that the program will not give the 8087 an instruction before it is ready to execute it.)

The WAITs are automatically inserted before all operations except the eight nonwaiting instructions FNCLEX, FNDISI, FNENI, FNINIT, FNSAVE, FNSTCW, FNSTENV, and FNSTSW. For each of these, Intel also specifies a waiting form (FCLEX, FDISI, FENI, FINIT, FSAVE, FSTCW, FSTENV, and FSTSW). An in-depth look at why these instructions are special is beyond

the scope of this article and will not be necessary for most applications of the 8087 on the IBM PC. (For more information, see Intel's *Numerics Supplement* book mentioned earlier.) Suffice it to say that the nonwaiting instructions are handled in the same manner as the directly translated types without preceding the escape sequence with a WAIT command.

Integer Operation Instructions

These instructions deal with integer operations, which on the 8087 always use an integer operand from memory as a source. The three types of integer operands are word-integer (16 bits), short-integer (32 bits), and long-integer (64 bits).

The integer operation instruction is implemented as a macro by use of the INT_SIZE nested macro. All macro invocations of an integer instruction must specify the type of operand followed by the memory address at which that integer operand is to be found. For example:

```
FIADD WORD CURRENT_SPEED
; where CURRENT_SPEED is a
; label to a memory location
```

or

```
FIMUL SHORT [BP].SEQUENCE
; where register BP is index
; offset by value in SEQUENCE
```

FREE SHIPPING

IBM® Personal Computer Products

Davong 5 MB Hard Disk System - \$1495.00 12 MB - \$1995.00

IBM PC-2 Drive System \$ CALL
3" DUAL DRIVE SUBSYSTEM \$725.00

Quadram - Quadboard with Parallel

Port, Serial Port, Clock/Calendar, Expandable to 256K

64K on brd. - \$340.00 128K on brd. - \$395.00
192K on brd. - \$439.00 256K on brd. - \$499.00

Quadram Memory Expansion

192K Maximum
64K on brd. - \$230.00 128K on brd. - \$290.00
192K on brd. - \$350.00

AST & PERYSY MEMORY EXPANSION PRODUCTS \$ CALL

Amdek Monitors

Mod 300 Phosphor - \$150.00 Composite Color III - \$345.00
IBM RGB Compatible Color II - \$599.00 Color I - \$300.00

IBM/TRS 80 Disk Drives/Cabinets

TM 100 Single 40 Track Drive - \$189.00
TM 100-2 Double 40 Track Drive - \$280.00
TEAC 5 1/4" SLIM SINGLE & DOUBLE DRIVE SUBSYSTEMS \$ CALL

Apple II® Computer Products

SYSCOM APPLE COMPATIBLE SYSTEM \$825.00
Apple Compatible Controller Card \$ 79.95
Apple Compatible Disk Drive w/Cabinet & Cable 249.00
w/Controller 315.00
TEAC SLIM LINE 5 1/4" DRIVE \$265.00 **DUAL SLIM LINE** \$525.00
Printer/Graphics Interface 99.95
Davong 5 MB Hard Disk System - \$1495.00 - 12 MB - \$1995.00
Apple Compatible Joysticks 29.95

Epson/Smith-Corona Printers

MX80 \$425.00 FX80 \$550.00 MX100 \$675.00

TRS 80 / Parallel Printer Cable \$20.00

IBM Parallel Printer Cable \$35.00

STAR MICRONICS GEMINI 10 \$ CALL

GEMINI 15 \$ CALL

Smith Corona TP-1 Letter Quality Daisy Wheel \$575.00

JMR ELECTRONICS INC.

TRS-80 MOD III Disk Controller Incl. Disk Controller, Power-Supply, Mounting Hardware, Cables & Instruction Manuals \$239.00

POWER SUPPLIES AND CABINETS Dual 8" Slim Line - \$180.00 Dual 5 1/4" - \$ 99.00
Single 5 1/4" - \$ 89.00

3" DUAL DRIVE SUBSYSTEM FOR IBM \$725.00

VISA, MASTERCARD (\$100 Min. Add 2%)
Or Certified Check

90 Day Warranty (Parts & Labor)
TRS 80 is a Registered Trademark Tandy Corp.
Prices Subject to Change Without Notice

DATA-MAIL
P.O. Box 818, Reseda, CA 91335
1-800-635-5555

FREE SHIPPING IN CONTINENTAL U.S.

(213) 993-4804
(IN CALIF.)

MICRO



TO ORDER OR INFORMATION LINE
(213) 704-6895

IBM SPECIAL OF THE MONTH IBM

DISK DRIVES FOR THE PC AND PC COMPATIBLES
DOUBLE SIDED/DOUBLE DENSITY 320K



MSL
\$525.00

OUR PRICE
\$225.00

ONE YEAR WARRANTY



APPLE II PLUS

PLUG-COMPATIBLE DRIVES

RANA ELITE I

W/CONTROLLER	W/OUT CONTROLLER
MSL 549.00	MSL 449.00
OUR PRICE 399.00	OUR PRICE 329.00

MICRO-SCI A2

W/CONTROLLER	W/OUT CONTROLLER
MSL 519.00	MSL 409.00
OUR PRICE 379.00	OUR PRICE 299.00



PERSONAL COMPUTER



INCLUDES:
2 Drives DS/DD
Color Graphic Board
64K Memory

MONITOR
NOT INCLUDED

MSL
2995.00

OUR PRICE *Save*
\$2499.00

496.00

*Subject to availability

NEW! IBM XT-



THE IBM PC WITH 128K, 10 MB WINCHESTER ON LINE, DOS 2.0. ASYNCHRONOUS INTERFACE

OUR LOW PRICE **\$4595.00**

THE APPLE COMPATIBLE ALTERNATIVE WITH COLOR

FRANKLIN BUSINESS SYSTEM



Franklin Ace 1000 system • 64K • Disk Drive with controller card • 12" green phs. video monitor.

\$1395.00

SAVE \$1000 COMPARED TO APPLE SYSTEM

EXPAND YOUR IBM PC MEMORY:

	MSL	OUR PRICE <i>Save</i>
FROM 64K TO 128K	108.00	63.00
FROM 64K TO 192K	216.00	111.00
FROM 64K TO 256K	324.00	179.00

FULL INSTRUCTIONS INCLUDED

NEC 3850

SPINWRITER LETTER QUALITY
PRINTER FOR IBM PC
Parallel, Bidirectional, 35 CPS
w/updated instructions.
NOW COMPATIBLE WITH WORD STAR

MSL
3495.00

OUR PRICE *Save*
\$2059.00

1436.00

MICRO PRO WORD STAR

	MSL	OUR PRICE <i>Save</i>
5M	995.00	369.00
10M	2495.00	126.00

DAVONG

OSI 501 Hard Disk 5M MSL 995.00
10M 2495.00

MICROSOFT

64K Ram Card w/parity 350.00 249.00
128K Ram Card w/parity 525.00 375.00
256K Ram Card w/parity 875.00 649.00

XEDEX BABY BLUE

64K plus 600.00 MSL 439.00
CP/M 2.2

KAYPRO II PROFOUNDLY PORTABLE



WITH 9" MONITOR, CP/M, Perfect Writer, Perfect Calc., Perfect Filer, Perfect Speller S-BASIC

MSL
1795.00

CALL FOR PRICE

OSBORNE PERSONAL COMPUTER



DOUBLE DENSITY
INCLUDES SOFTWARE

- CPM
- WORDSTAR
- SUPERCALC
- MAIL MERGE
- CB BASIC
- M BASIC

OUR PRICE
CALL

APPLE PERSONAL COMPUTER PERIPHERALS AND SOFTWARE



HARDWARE	MSL	Our Price
Videa Combo Package	375.00	259.00
Videa Videolem Card	345.00	239.00
Videa Keyboard Enhancer II	149.00	115.00
Microsoft Softcard with CP/M	345.00	235.00
Microsoft Premium Pak	695.00	499.00
Microsoft 16K Card	99.95	72.50
PCP App'l - Card (4 MHz version)	445.00	339.00
PCP App'l - Card (6 MHz version)	595.00	449.00
Corvus Winchester 5MB	2,495.00	1,949.00
Corvus Winchester 10MB	3,495.00	2,849.00
Corvus Winchester 20MB	4,495.00	3,699.00
Saturn Systems 32K	249.00	169.00
Saturn Systems 64K	425.00	312.00
Saturn Systems 128K	599.00	452.00
Hays Micromodem II	379.00	285.00
Hays Smartmodem	279.00	225.00
Kensington System Saver	90.00	68.00
M & R F Modulator	30.00	22.00
M & R Super Fan	50.00	37.00
Grappler +	175.00	135.00
Practical Peripherals		
Microbuffer II 16K	259.00	225.00
Practical Peripherals		
Microbuffer II 32K	299.00	239.00
Prometheus Versa Card	199.00	149.00
SVA Disk 2+2 Controller: DSSD	395.00	335.00
SVA Disk 2+2 Controller: OSSD	595.00	489.00
SVA App'l Cache 256 K Memory	1,200.00	1,049.00
TG Joystick	59.95	42.00
TG Select-A-Port	59.95	42.00
Wesper Micro Wizard 80	249.00	179.00
Wesper Micro BPO 16K	179.00	139.00
Wesper Micro BPO 32K	219.00	159.00
Wesper Micro SDB 16K	249.00	189.00
Wesper Micro SDB 32K	279.00	229.00
BMC 1401 w/RGB Interface	595.00	319.00
ALS Z Card w/CPM for Apple II	349.00	209.00

IBM PERSONAL COMPUTER PERIPHERALS & SOFTWARE



HARDWARE	MSL	Our Price
QUADRAM Quadboard, 4 function bnd with 64 K	995.00	349.00
with 256 K	995.00	549.00
Quad Colon II		
With 640x240 Resolution	575.00	439.00
Quad Colon III		
With 640x400 Resolution	850.00	669.00
Printer Card w/cable (parallel)	159.00	109.00
Printer Card w/cable (serial)	179.00	139.00
Davong Hard Disks		CALL



SOFTWARE	MSL	Our Price
Zork I by Infocom	39.95	28.50
Zork II by Infocom	39.95	28.50
Zork III by Infocom	39.95	28.50
Snooper Troops #1 by Spinnaker	44.95	33.50
Snooper Troops #2 by Spinnaker	44.95	33.50
Deadline by Infocom	49.95	37.50
Flight Simulator by Microsoft	49.95	37.50
Starcross by Infocom	39.95	28.50
Story Machine by Spinnaker	34.95	26.50
The Home Accountant		
by Continental	150.00	111.00
VisiCalc by VisiCorp	250.00	189.00
Wordstar by Micropro	415.00	369.00
The Tax Manager by Microball	250.00	189.00
VisiView by VisiCorp	300.00	229.00
Supercalc by Sorcim	295.00	229.00
dBase II by Ashton Tate	700.00	489.00
Personal Investor by PBL	145.00	119.00

NEW INVENTORY IN STOCK
PRICES HAVE BEEN LOWERED
PLEASE CALL FOR BEST PRICES

CP/M is a registered trademark of Digital Research, Inc.

LOTUS 1-2-3

A POWERFUL, FAST AND MOST PRODUCTIVE SOFTWARE FOR YOUR MONEY: INTEGRATED SPREAD SHEET, DATA BASE AND GRAPHICS

MSL 495.00

OUR PRICE *Save*
395.00

100.00

TERMINALS TELEVIDEO

	List Price	Our Price
910	\$699.00	\$599.00
912C	950.00	699.00
920C	995.00	795.00
950C	1,195.00	949.00

PRINTERS

EPSON	MSL	Our Price
Epson MX-80 T Type III*	645.00	CALL
Epson FX-80F/T	699.00	CALL
Epson MX-100 Type III*	995.00	CALL
*w/graphics		
OKIDATA		
Okidata 82A w/tractor 80 col	549.00	409.00
Okidata 83A w/tractor 132 col	899.00	709.00
Okidata 84P 132 col serial	1395.00	1019.00
Okidata 84S 132 col parallel	1495.00	1177.00
C. ITOH		
C. Itoh F 10 40 cps (parallel)	1795.00	1377.00
C. Itoh F 10 40 cps (serial)	1895.00	1439.00
C. Itoh Prowriter (parallel)	695.00	519.00
C. Itoh Prowriter (serial)	749.00	565.00
SMITH CORONA		
TP-1 Letter Quality Tractors	895.00	599.00
STAR MICRONIC		
Gamma 10	495.00	379.00

MODEMS

NOVATION	MSL	Our Price
Cat	189.00	149.00
D-Cat	199.00	159.00
Auto-Cat	249.00	209.00
212 Auto-Cat	695.00	629.00
Super-Mike	14.95	12.95
Apple Cat II	389.00	289.00
212 Apple-Cat	725.00	619.00
HAYS MICROCOMPUTER PRODUCTS		
Hays Stack Smartmodem	289.00	229.00
Smart Modem 1200	699.00	529.00
Micromodem 100	399.00	299.00
ANCHOR AUTOMATION		
Signalman Modem MK I	99.00	79.00
Mark VII (Auto Answer/Dial)	159.00	125.00

SOFTWARE

CHOPFLIFTER by Broderband	MSL	Our Price
34.95	26.20	
FRUGGER by Sierra On-Line	34.95	26.20
Canyon Climber by Datasoft	29.95	22.50
Wizardry by Sir-Tech	49.95	37.50
Zork by Infocom	39.95	29.95
Snooper Troops #1 by Spinnaker	44.95	33.75
Deadline by Infocom	49.95	37.50
Apple Panie by Broderband	29.95	22.50
Master: Type by Lightning	39.95	29.95
Typing Tutor II by Microsoft	24.95	18.75
Story Machine by Spinnaker	34.95	29.95
The Home Accountant		
by Continental	74.95	56.50
PFS: File by Software Publishing	175.00	131.25
VisiCalc by VisiCorp	250.00	189.00
PFS: Report by Software Publishing	95.00	71.25
Screenwriter II by Sierra On-Line	129.95	97.50

MONITORS

TAXAN	List Price	Our Price
12" Grn. Phs 18 MHZ	195.00	109.00
12" Amber 18 MHZ	229.00	139.00
12" RGB	CALL	CALL
NEC		
JB 12" Green	249.00	175.00
JC 12" Color	495.00	345.00
USI		
Pl-2 12" Green	249.00	155.00
Pl-3 12" Amber	289.00	185.00
AMDEK		
300 12" Green	195.00	145.00
Color I	395.00	325.00
Color II RGB Highres	895.00	695.00
ELECTROHOME		
ECM-1302-1 13" RGB Hires	595.00	395.00
ECM-1302-2 13" RGB Hires	895.00	595.00
Color Board for Apple II	249.00	195.00

MICRO BUSINESS WORLD MAIL ORDER

20929 Ventura Blvd., Woodland Hills, CA 91364 (213) 704-6895

OUTSIDE CA CALL TOLL FREE 1 (800) 429-5886 IN CA (213) 996-2252

Name (Please print) _____
Address _____
City _____ State _____ Zip _____
Qty Make Model Description Price Total

Qty	Make	Model	Description	Price	Total

Certified Check or M.O. Allow 2 weeks clearance for personal check
Bank Wire Transfer

CREDIT CARD # _____ Exp. Date _____ Signature _____

We reserve the right to correct typographical errors. This ad supersedes all previous ads. Prices subject to change without notice.
*California residents add 6% sales tax.
**Add 3% Shipping & Handling — Add 3% surcharge for credit cards. No C.O.D.'s. Order cannot be shipped unless accompanied by payment, including shipping, handling and tax where applicable. Minimum service charge \$5.00.

TOTAL ORDER \$ _____
TAX IF APPLICABLE* _____
SHIPPING & HANDLING** _____
TOTAL ENCLOSED \$ _____

VISA

The integer macros receive two parameters, P1 and P2, from the user's program. P1 specifies the type of operand ("WORD" and "SHORT" from the examples above). P2 contains the memory address and can be any valid addressing scheme permitted by the assembler ("CURRENT_SPEED" and "[BP].SEQUENCE" from the examples above).

The integer macros then turn and call the INT_SIZE macro, passing to it the two parameters as well as up to three other parameters (XXX_S, XXX_W, and XXX_L—see the definition of INT_SIZE in listing 1). These are individual values that form part of the escape sequence depending on whether the type parameter is WORD (XXX_W), SHORT (XXX_S), or LONG (XXX_L).

The INT_SIZE macro uses the conditional assembly-language pseudo-ops to compare the type strings and determine which escape sequence to use. If the operand type is none of the valid or expected types, then an "ERROR in macro" message is inserted instead of an escape sequence, causing an assembly-language error to occur later.

Variety Instructions

The last type of instruction macro is variety and includes the 19 remaining instructions. Basically, these instructions are similar in that the source operand can be specified in a variety of ways, including the classical stack, register, and real-memory forms.

The variety macro type uses the CHOOSE_4 nested macro to issue the proper escape sequence. The instruction macro passes to CHOOSE_4 any parameters it received in its invocation (from the user program) as well as some instruction-specific parameters. CHOOSE_4 then examines its parameters (as many as six) and determines what the escape sequence should be.

The classical stack and register variations of the variety type include four types of operands: none, "ST(i)" (for single-operand instructions), "ST,ST(i)", and "ST(i),ST". CHOOSE_4 receives the operands as dummy parameters P1 and P2. In place of the *i* will be the user-specified register number (0 to 7) used to determine the escape sequence.

The variety instruction type includes all the real-number instructions (such as FADD, FSUB, FDIV, etc.). These real-number instructions can be of the classical stack or register type just mentioned or of the real-memory type. The real-memory operand type specifies that the source operand is found somewhere in the 8088 memory space. The operands of this type can be of various lengths ("SHORT", "LONG", and "TEMP"). Examples of the variety instructions are

FLD ST(4)

; Push stack once and move contents of reg 4
; to top of stack

FADD SHORT DISTANCE

; Add "short" real-memory operand found
; at memory address "DISTANCE" to top
; value on stack, leave result on TOS

FDIVP ST(4),ST

Text continued on page 358

FREE CP/M PLUS

SAVE \$350 WITH SPECIAL TARBELL PACKAGE

Buy Tarbell's Z-80A S-100 CPU/IO board and Double Density Floppy Disk interface, and get free new Digital Research CP/M Plus.

CP/M Plus features: high performance file system CP/M 2.2 compatible time and date stamps on files automatic disk login of removable media support for 1-to-16 banks of RAM and 1-to-16 drives up to 512 megabytes each easy to use system utilities with HELP facility banked or non-banked memory and high speed loading.

Total price is \$945. Ask nearest Tarbell dealer for demo.

CURRENT EMPIRE OWNERS: Special low prices for upgrading your unit to CP/M Plus. Call for details.

Tarbell
Technologies

950 Dovlen Place
Suite B
Carson, CA 90746
(213) 538-4251

OUR ISOLATORS FOR YOUR PROTECTION

Prevents:

disk drive woes, printer interaction,
memory loss and damage due to
lightning or AC power line
disturbances.



Commercial Grade Isolators

ISO-1 3 Isolated Sockets	\$76.95
ISO-2 2 Isolated Socket Banks, 6 Sockets	76.95

Industrial Grade Isolators

ISO-3 3 Double Isolated Sockets	115.95
ISO-11 2 Double Isolated Banks, 6 Sockets	115.95

Laboratory Grade Isolators

ISO-17 4 Quad Isolated Sockets	200.95
ISO-18 2 Quad Isolated Banks, 6 Sockets	169.95

Circuit Breaker, any model (Add-CB)	Add 10.00
Remote Switch, any model (Add-RS)	Add 18.00

ESP Electronic Specialists, Inc.

171 South Main Street, Box 389, Natick, Massachusetts 01780

Toll Free Order Desk 1-800-225-4878
MasterCard, VISA, American Express

Just rewards of taking a tried and true path.

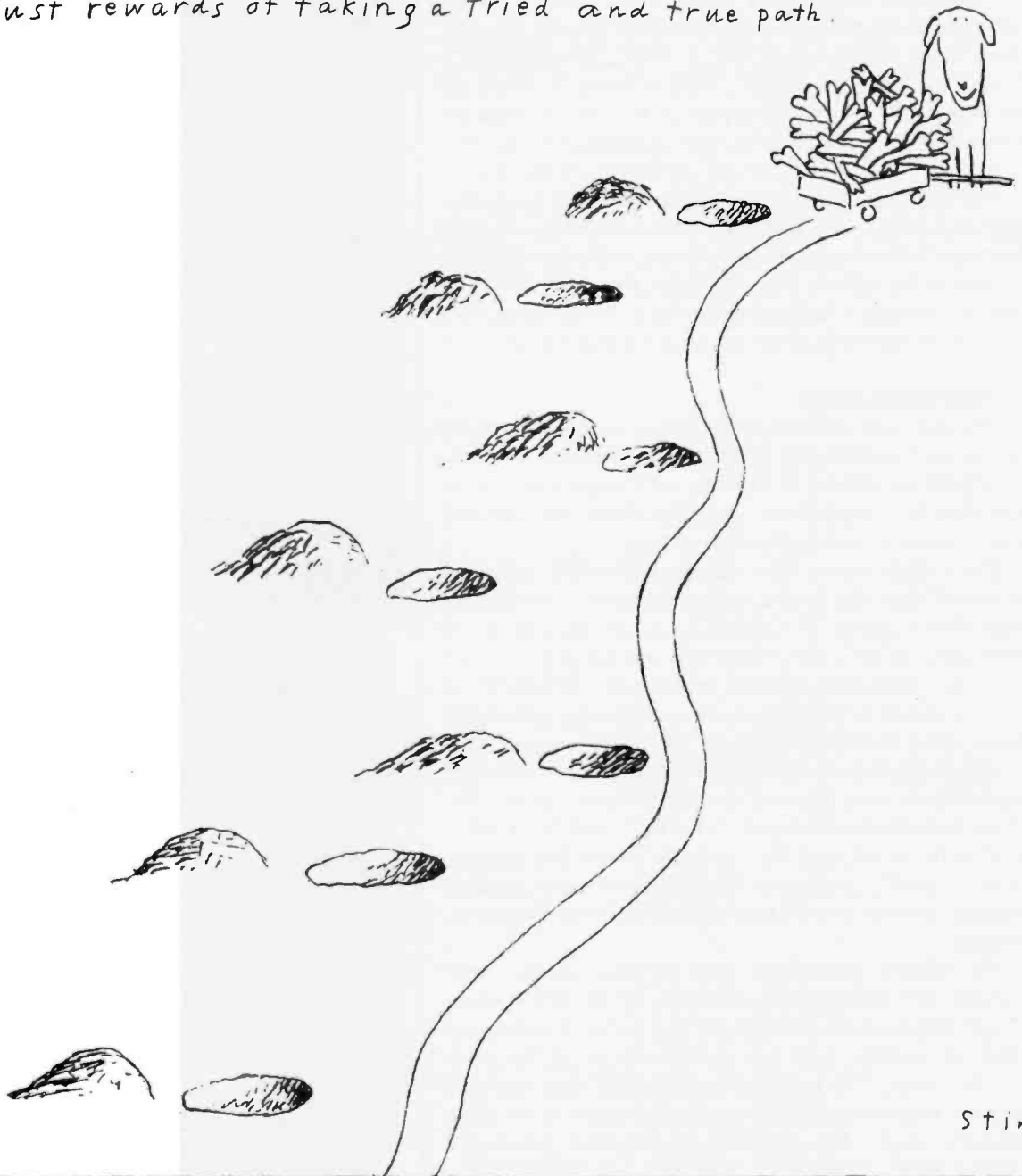

Stine

WordStar runs on the IBM PC, Apple Computer with CIP/M[®] card and all CIP/M[®]-based computers. IBM, Apple and CIP/M are registered trademarks of IBM Corp., Apple Computer Inc. and Digital Research Inc., respectively.

For the name of the dealer nearest you, phone (800) 227-2400, ext. 948; in California, (800) 772-2666, ext. 948. For more information

WordStar® is used by more people, more often, to do more things than any other word processing software.

And you'll find it'll do more for you.

The only surprise you'll get with WordStar is how much you can do with it.

Ask Arthur C. Clarke. He used WordStar to write his best selling novel, 2010: Odyssey Two.

Ask Osborne-McGraw Hill. Where the editors use it to produce all the books.

Or, for that matter, ask any of over 400,000 others who swear by WordStar's reliability when it comes to making fast work of the written page.

And no wonder.

WordStar has more work-saving features to take the time and drudgery out of revising and retyping than any other word processing software. For instance, there are production typing features to let you move columns around and merge paragraphs from different documents at the touch of a key. Along with print features like boldfacing and centering to make any late-night typist look like a pro.

But that's not to say you have to be a pro. WordStar starts off by simply giving you a choice, and then guides you with menus every step of the way. Menus adjust to your proficiency. And of course, what you see on the screen is what you get on paper.

Then as your needs grow, WordStar can grow right along with you. With options like MailMerge®, SpellStar® and StarIndex™ to help you personalize form letters, correct spelling and create indexes. And with other MicroPro products like InfoStar™ and CalcStar™ so you can automatically insert business data and financial projections into WordStar documents.

WordStar runs on almost every personal computer. Which means you don't have to go out of your way to find the word processing software that can do more for you.

Just take a walk over to your local computer store and ask for WordStar. You'll be on the right path.



MicroPro®
Software that means Business

```

; Divide top of stack into reg 4
; in 8087 reg set and leave result in
; reg 4, pop top-of-stack after done

```

The **CHOOSE_4** macro uses two submacros: **CHECK_ST** and **ESC_REG**. **CHECK_ST** is called with a parameter that **CHOOSE_4** thinks is in the range "ST(0)" to "ST(7)" (from ST(i)). If it is in this range, **CHECK_ST** returns a value "REG" equal to i, which is then used in the escape sequence. If the parameter string is not in this range, then **REG** is set equal to -1 and is returned.

Once the **CHOOSE_4** macro determines that the instruction is using the "ST(i)" form and determines i, it invokes **ESC_REG** to determine the final escape sequence for the instruction. If the instruction is a real-memory type, **CHOOSE_4** itself issues the escape-sequence instruction for the assembler.

Each of the 77 instruction macros in listing 1 is fully commented to specify the legal operands and types for that instruction. When specifying an operand from memory for either the integer or real operations, the user program must specify the type of operand to be used. The instruction form should be <operation-name operand-type operand-address>. Valid types for integers are **WORD**, **SHORT**, and **LONG**. Valid types for reals include **SHORT**, **LONG**, and **TEMP**. Only the **FILD** and **FISTP** (integer load, integer store and pop) instructions

use long integers. Likewise, only the **FLD** and **FSTP** (real-number load, real-number store and pop) instructions use temporary reals. Here are two 8087 instructions that use operands from memory:

```

FIADD    WORD    INT_ADDR
;
; adds WORD-integer (16 bits) found at
; INT_ADDR to top value on 8087 stack.
; Result is left on top of stack.
;
FADD     LONG    [BX].TIME_VAL
;
; adds LONG-real (64 bits) found by indexing
; off of 8088 CPU internal register BX plus
; offset TIME_VAL to top value on 8087 stack
;

```

Because M8087 is designed to be as efficient as possible, it does not contain much error-checking capability. Therefore, you may discover invalid operand types in 8087 instructions that M8087 will happily translate into some incorrect escape sequence. The results of any such occurrence are undefined.

For example, if you try to assemble the invalid command "FADD TEMP VARIABLE" (invalid because **FADD** can use only short and long real-memory variables, not temporary reals), M8087 will not spot this as an error. The valid operand types for all 8087 instruc-

IBM PC-8087 SUPPORT FROM MICROWARE

87FORTRAN/RTOS™ is a full ANSI-77 subset with 8087 extensions. It generates in line 8087 code allowing use of all 8087 data types, including 32, 64 and 80 bit reals and 64 bit integers. The complete subset I/O is supported including Internal and External Files and List Directed I/O. Exceptions allow the generation of recursive subroutines, interrupt handlers and can cause interrupts from FORTRAN. 87FORTRAN/RTOS uses the Intel large memory model, allowing data/code structures which utilize the full megabyte. The compiler provides direct access to 8088 ports and supports logical operations on 8 and 16 bit operands normally treated in assembly language. 87FORTRAN/RTOS is ideal for applications which are number intensive or control hardware. 95% of all "main frame" size programs compile and run without extensive editing. The price includes support for one year and RTOS. **\$1350**

87PASCAL/RTOS™ is the most powerful compiler available to PC users at this time. It is an ISO-Standard Pascal, with 8087-8088 exceptions. These make it possible to use all the 8087 data types directly, while generating modules in one of the three Intel Memory Models. Modules produced using different memory models can be interfaced and linked. This gives the user complete control of the memory model/speed trade off characteristic of iAPX cpu's. All exceptions to the ISO definition are clearly marked with a grey background in a manual which is a standard of the industry, and more readable than many tutorials. The compiler makes it possible to cause or handle interrupts. It also reads ports and performs all the tasks necessary to control iAPX-86 hardware. Use of 87PASCAL guarantees you upward compatibility with future Intel processors and languages. Includes RTOS. **\$1350**

MicroWare 8087 Products

87MACRO™ - the key to writing 8087 assembly language routines using the IBM assembler. It contains a complete library of standard 8087 routines. **\$150**

87BASIC™ - includes patches for BASCOM.COM, BASCOM.LIB and BASRUN.EXE and the MicroWare 8087 runtime routines. **\$150**

87PASCAL™/87FORTRAN™ - 8087 libraries and IBM compiler patches, either for. **\$150**

BAS87+™ or PAS+87™ - libraries of 8087 primitives which make it possible to write assembly-like routines in Basic or Pascal, either for. **\$50**

87FASTPAK™ - includes your choice of one MicroWare runtime library, the 87/88 Guide, an 8087, and installation instructions. **\$375**

8087 CHIP - plus chapter five of the GUIDE. **\$223**

87/88GUIDE - an excellent tutorial on writing 87/88 code and interfacing it with compilers-full of code that runs! **\$30**

SuperSoft Fortran. **340**

SuperSoft 87 drivers. **50**

MATRIXPAK. **150**

Microsoft Fortran 2.0. **340**

Microsoft Pascal 2.0. **340**

Microsoft Business Basic Compiler. **495**

Microsoft C Compiler. **450**

CI/C86. **345**

64K Ram sets. **64**

STSC APL★PLUS/PC. **595**

RTOS™ — Real Time Operating System

RTOS is a MicroWare configured version of iRMX-86, Intel's legendary real time operating system. This DOS is entirely re-entrant and provides many features found only on mainframes. It includes the Intel Assembler, ASM-86, which supports the 8086, 8087, 8088 and 80186. All modules produced by the compilers or ASM-86 are combined, loaded and managed with the Utilities LINK-86, LOC-86 and LIB-86. These products make it possible to load modules anywhere in RAM, and resolve external references between runtime modules. Overlays with a single root job are supported by the linker. Binding of modules is accomplished at link or load time. RTOS/ASM-86/LINK-86/LOC-86/LIB-86. **\$600**

**Micro
Ware**

P.O. Box 79
Kingston, MA
02364
(617) 746-7341

**You Can
Talk To Us!**

LSI 11/23 PLUS COMPUTERS WITH UP TO 4 MEGABYTES RAM MEMORY

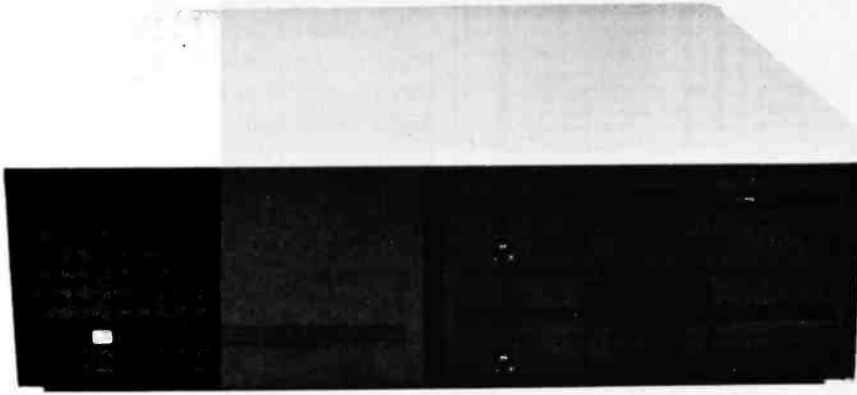

CI-103	DESKTOP COMPUTER — Complete computer system enclosed within a VT103 video terminal with LSI 11/2 and 64KB Memory	\$3100.00
	With LSI 11/23 and 256KB Memory	\$4100.00
	With LSI 11/23 PLUS and 1 Megabyte Memory	\$5395.00
CI-11/23 AC	LSI 11/23 CPU with MMU, 256K byte RAM Memory. Power supply, 8x4 backplane, in a rack mountable chassis	\$2675.00
	Same with LSI 11/23 PLUS and 1 Megabyte Memory	\$4395.00
CI-11/03 LK	LSI 11/2 CPU with 64K byte RAM Memory. Power supply, fixed and floating point instruction set (KEV11) and 8x4 backplane in a rack mountable chassis	\$1845.00
CI-520	10 Megabyte Winchester with 2 Megabyte 5¼" floppy RX02/RL02 or RX50/WD50 emulation	\$3995.00

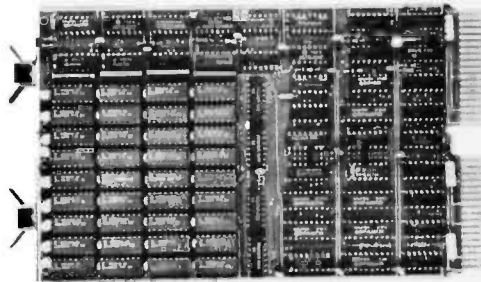

256KB TO 1 MEGABYTE OF MEMORY ON A DUAL WIDTH CARD

- On board parity generator with CSR
- Addressable as a contiguous block in 256KB increments
- Battery back-up mode

SINGLE QTY. PRICE: 256KB **\$ 595.00**

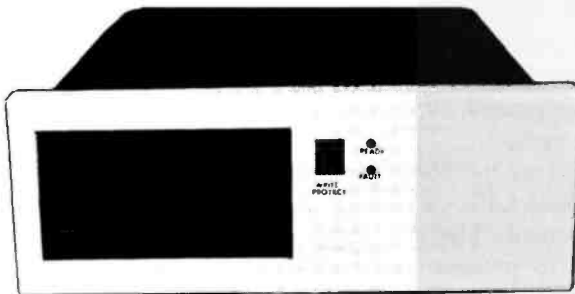

CI-1240-WF 42 Megabyte Winchester disk system with controller and 2MB floppy backup **\$6995.00**

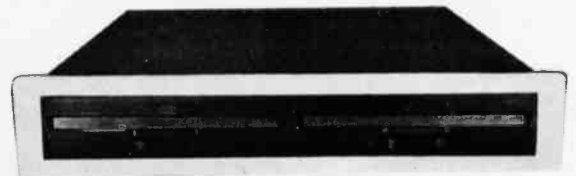

CI-1220-TF Dual drive, double density, double sided, 2MB capacity floppy plus DMA LSI 11 controller occupying 3½" of vertical space ... **\$2695.000**

DON'T ASK WHY WE CHARGE SO LITTLE, ASK WHY THEY CHARGE SO MUCH.



Chrislin Industries, Inc.

31352 Via Colinas • Westlake Village, CA 91362
Telephone: 213-991-2254 • TWX 910-494-1253 CHRISLIN WKVG

LSI and DEC's are trademarks of Digital Equipment Corporation

OF ALL THE THINGS YOU BUY, HOW MANY ARE GOOD ENOUGH TO BE WARRANTED 5 YEARS?

Few disks stand the test of time. Because few are built to the precision standards or certified to the critical levels of Omni's complete line.

Each Omni disk is rated for 12 million passes without disk-related errors or significant wear. Each is certified error-free at a minimum of twice the error-

threshold of your system. And built to exceed all industry specifications including those of ANSI, ECMA, ISO and virtually every drive manufacturer. So you can count on them for the long haul. We guarantee it.

Call toll-free (800 343-7620) for your nearest dealer. In Mass., call 617 799-0197.

Omni Resources, 4 Oak Pond Ave., Millbury, Mass. 01527

Dealers. Software houses. Check our prices, services and specifications. We offer duplicating, formatting, private labeling, small minimums, fast delivery and copy protection schemes on disks for virtually any system.



OMNI

**THE DISK GOOD ENOUGH
TO BE WARRANTED 5 YEARS**

Interchanging Real-Value Formats

Real numbers are generally stored in a three-field binary format similar to exponential or scientific notation. One field is a sign bit (signifying whether the number stored is positive or negative). The second field is the significand field (also called the mantissa), which stores the number's significant digits. The third field is the exponent field, which contains the value of the exponent of the real number. The sizes of the significand and exponent fields vary as the number of bits used to store the value in varies.

Unfortunately, while the 8087 NDP hardware and the IBM PC software both use the same basic approach to storing real numbers as described above, they do not use identical formats. This means that a real number entered from IBM BASIC or Pascal cannot be directly moved into the 8087 and used for computational purposes. Numbers must be transformed from IBM to 8087 format and then, after all computations are finished, converted back from 8087 to IBM format.

The differences between the two formats are in the way that the three fields of the real number are stored and the treatment that the binary exponent receives. For a 32-bit short-real number (the size used by BASIC and Pascal), both 8087 and IBM formats designate 1 bit for the sign, 8 bits for the exponent, and 23 bits for the significand. The IBM format places the 8-bit exponent in the first byte by itself, the sign bit in the first bit of the second byte, and the 23-bit significand in the remaining bits. This scheme makes manipulation of the exponent byte easy to do in software.

The 8087, concerned with maximizing the processing of these numbers in hardware, places the sign bit in the upper bit of the first byte, the exponent gets the remaining 7 bits in that byte and the upper bit in the second byte, with the significand getting the remaining 23 bits.

[Editor's Note: Both real and integer numbers in Intel format are read from the byte with the highest address to the byte with the lowest address. Thus, given a 32-bit real number in bytes n through $n+3$, the "first" byte talked about in these paragraphs is byte $n+3$, the "second" byte is $n+2$, and so on. . . .G. W.]

Thus, to move a number from IBM format to 8087 format, we must save the sign bit of the number (from bit 7 of the second byte), shift the first byte right one bit with the lowest bit being placed into the upper bit of the second byte, and then placing the sign bit into bit 7 of the first byte. Converting from 8087 to IBM reverses the operation.

Finally, converting between the IBM and 8087 formats requires changing the exponent field in a way called biasing. The two formats are slightly different in their requirements. The differences lie once again in the fact that the IBM-format real numbers are set up to allow easy use from software and 8087-format numbers are optimized for hardware manipulation.

The 8087 format biases the exponent by adding a bias value to the true exponent. The size of the bias exponent depends on the type of real number being used: a short-real number adds a bias value of 127 (decimal), a long-real number uses 1023, and a temporary-real number uses 16,383.

The IBM format uses a different biasing scheme, the end result of which is that the IBM format exponent is 2 greater than the 8087 format. To convert from the IBM to the 8087 format, subtract 2 from the exponent. Add 2 to the exponent to go from 8087 to IBM format. There is one exception to the conversion processes. The real number 0.0 is stored as all zeros in both formats.

Listing 2 contains two assembly-language routines that convert short-real numbers from IBM to 8087 format (C_IBM_8087) and vice versa (C_8087_IBM). These efficient conversion routines require less than 20 microseconds to convert a short-real number. Similar routines are easily implemented for long-real-number conversions (however, IBM's Pascal does not use double-precision real numbers).

In any user-application program, it is the user's responsibility to keep track of the current format of any number. Usually, the numbers need be converted only when they are input from the user and then again when they are output to the user. Most intermediate steps can leave the numbers in 8087 format.

CHK_CONC macro in M8087. Basically, this macro is called from CHOOSE_4 and INT_SIZE whenever any external variable reference is made by an 8087 operation. It includes a user-settable flag (named AUTOSYNC) that determines whether CHK_CONC will do anything or not.

If the AUTOSYNC flag is set (i.e., has a nonzero value), then any call to CHK_CONC will result in a WAIT instruction being inserted immediately after the 8087 instruction that accesses the external variable. This forces the 8088 to wait until the 8087 instruction is finished, thus ensuring exclusive access to the variable by the 8087. The AUTOSYNC flag is set by default and must be explicitly cleared (simply by inserting the line "AUTOSYNC = 0" anywhere in the assembly-language source code) to disable the forced concurrency.

If the user knows that no problem will exist between the 8088 CPU and the 8087, then the AUTOSYNC flag should be cleared. This saves both memory space (a WAIT instruction takes up a byte) and execution time

and allows exploitation of the parallel processing capabilities of the 8088/8087 system.

Performance of M8087

So how well does M8087 work? Well, it works very well from every point of view except assembly time. After a little practice, the 8087 mnemonics become second nature (much as the standard 8088 assembly-language mnemonics). However, the lengthy macros that M8087 uses can significantly increase the time it takes to assemble an assembly-language file that uses 8087 mnemonics. But let me reiterate that this is a one-time cost that occurs only when you create the executable object-code file (which runs extremely fast).

I created several short utility programs needed to use the 8087 in the IBM PC. The first, explained in the text box "Interchanging Real-Value Formats" and given in listing 2, converts real-value numbers between the slightly different formats used by IBM software and the 8087.

*Text continued on page 372
Listing on page 366*

Statpro™

The most comprehensive statistics and graphics ever developed for and sophisticated database workstation the personal computer.

Years of research, development, and field testing have resulted in the most extensive statistics and graphics database program specifically designed for the personal computing environment. STATPRO™ provides the data analysis capabilities and flexibility previously available only on a large computer. Researchers, business professionals, and other data analysts will welcome the breadth yet simplicity of this program! STATPRO requires no previous computer experience, no special command language. Single keystrokes access all of the data manipulation, statistics, and graphics power of STATPRO.

STATPRO allows easy access to its extensive numerical data capabilities.

The strength of STATPRO is found in the functions of its user friendly, menu-driven database. You can easily learn to enter and edit, manipulate, transform, and print out data. STATPRO's searching capabilities allow these functions to be performed on all your data or a user defined subset of your data.

Statistics Modules Menu

- A) DESCRIPTION
- B) REGRESSION
- C) ANOVA
- D) TIME SERIES
- E) MULTIVAR

(ESC) Exit to Master Menu
Choice -> []

Transformations and over 400 conversions are available. You can place the results of these transformations into the same field or any other field in STATPRO's database.

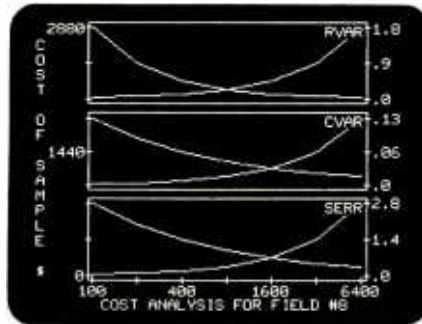

STATPRO offers a comprehensive collection of statistical procedures.

The statistics component of STATPRO contains a multitude of procedures, grouped into the following modules:

Descriptive: Contingency analysis, cross tabulation, normality tests; descriptive, comparative, range and non-parametric statistics.

Regression: Linear, non-linear, stepwise, and multiple regressions; residual analysis and statistical matrices.

Analysis of Variance: Single and nested classifications, two and three way equal and unequal sample size and non-parametric ANOVA.

Time Series: Moving averages, multi-stage least squares, fitted polynomials and trig functions, additive and multiply forecasting.

Multivariate: Principal components, factor, orthogonal factor, oblique factor, pair-weighted cluster, discriminant function, multiple contingency, and canonical correlation analysis.

STATPRO provides graphic representation of your data in minutes.

STATPRO graphics plot *all* the results of your STATPRO statistical analyses including scatter, triangle regression, and box plots; pie-

charts, histograms, and dendograms. Further, with STATPRO you can custom edit with any of four character sets from the keyboard. You can also edit using paddles, joystick or special graphics commands. Mix text with data fields. Place multiple plots on each screen. Define your axis limits.

You can save your graphics on a disk for a multiple color "slide show" presentation, or print them out through a variety of compatible printers.

STATPRO documentation wraps up the package.

Although STATPRO software is essentially self-documenting, complete print documentation is provided. This includes a walk-through Introductory Tutorial, a Menu Chart, and a comprehensive User's Guide for each STATPRO component.

STATPRO currently runs on all versions of the Apple® II personal computers. It will be available for the IBM® PC in September.

To find out more about Statpro: The Statistics and Graphics Database Workstation, contact your local dealer, or

Call us toll-free at

800-322-2208

In Massachusetts call (617) 423-0420.

You can also call us toll-free for information on corporate purchase through our National Account Program.

 **Wadsworth Electronic Publishing Company**

Statler Office Building
20 Park Plaza, Boston, MA 02116

STATPRO is a trademark of Wadsworth Electronic Publishing Company. Apple is a registered trademark of Apple Computer, Inc. IBM is a registered trademark of International Business Machines, Corp.

Call "THE COMPUTER-LINE" in Colorado

"Committed to bringing computers within the reach of all Americans"™

The Computer-Line believes that it is important to be competitive by offering low prices; however, we regard service as the most important aspect of a mail-order organization. All our lines are available so that you, the customer, are able to talk to fully qualified computer specialists trained to answer all your questions pertaining to our line of microcomputers. We are renowned for our excellent after-sales support and our promptness for delivery. Peace of mind and excellence in service is our pledge to all our customers.

PRODUCTS FOR THE IBM® PERSONAL COMPUTER

The Ultimate Peripheral for your IBM PC from MBI MONTE CARLO™ GT™ CARD

Five Functions — Memory/Serial/Parallel/Clock/Joystick

- Up to 1 Megabyte Expandable Memory
- One IBM Compatible Centronics Parallel Port
- One IBM Compatible Asynchronous Communication Port
- Clock/Calendar (Battery-backed) with Alarm
- Dual Port Joystick Interface
- Future Upgrade Options: Direct Connect Modem

SCALL

NEW from MBI:

Monte Carlo™ Quatro™

Same features as the GT, but without the joystick ports.

SCALL

MAYNARD ELECTRONICS

Floppy Disk Controller for IBM PC

- With Parallel Port \$219.00
- With Serial Port \$249.00

I-C — MAGIC

Prom Chip
Programmable Graphics Screen Dump

Print Spooling up to 64K Terminal Emulation SCALL

QUADRAM CORPORATION

Quadboard: The memory board for the IBM featuring:

- Fully Expandable from 64K - 256K
- Parallel Port
- Asynchronous (RS232) Serial Port
- Clock/Calendar
- RAM Disk Drive

SCALL

Microfazer:

- Buffering from 8K - 64K (4 - 32 pages of text)
- Printer & Computer independent
- Parallel/Parallel; Parallel/Serial; Serial/Serial available
- Compute while you print!

SCALL

TANDON DRIVE SPECIAL

Double Sided/Double Density;
320K Bytes of Storage
TM-100-2

ONLY \$245.00

SEIMANS DISK DRIVE

Double Sided/Double Density;
320K Bytes of Storage

ONLY \$245.00

SHUGART HALF HEIGHT DRIVE

Shugart Quality now available for your IBM

ONLY \$245.00

ACCESSORIES

T & G Products:

- Trak Ball \$ 45.00
- Joysticks \$ 45.00

MBI:

- Monte Carlo Joysticks \$ 39.00
- Joystick Adapter \$ 14.95

Gibson:

- Light Pen \$259.00

SOFTWARE

Ashton-Tate:

- D. Base II \$475.00

Continental:

- Home Accountant Plus \$ 99.00

Infocom:

- Zork SCALL
- Starcross SCALL

MicroPro:

- Wordstar \$329.00
- Mailmerge \$159.00

Sorclim Software:

- Supercalc \$199.00
- Superwriter \$299.00
- Spellguard \$149.00

Lifetree Systems:

- Volkswriter \$149.00

Vislcorp:

- 256K Visicalc \$185.00
- Visidex \$185.00

Peachtree:

- Peachpak SCALL

PERIPHERALS FOR ALL COMPUTERS

PRINTERS

C. Itoh Printers:

- Prowriter I Parallel \$ 379.00
- Prowriter I Serial \$ 499.00
- Prowriter II Parallel \$ 649.00
- Prowriter II Serial \$ 699.00

Okidata:

Microline 92: 160 CPS bidirectional with 40 CPS correspondence, 80 column \$529.00

Microline 93: 160 CPS bidirectional with 40 CPS correspondence, 132 column \$899.00

Pacemark 2350: 350 CPS bidirectional/2 color printing, 136 column.

- Parallel \$2099.00
- Serial \$2199.00

Pacemark 2410:

- Parallel \$2399.00
- Serial \$2499.00

Call for prices on all Okidata Printers!

IDS Prism:

- 132 Color \$1495.00

Smith Corona:

- TP-1 Parallel or Serial \$ 549.00

Star Micronics:

- New Gemini 10X, improved throughout!
120 CPS, Parallel SCALL

NEW! Juki:

- L Q, 18 CPS, Parallel SCALL



MONITORS

Amdek:

- Color I \$299.00
- Color II \$499.99
- 300G Green \$145.00
- 300A Amber \$159.00

BMC:

- Lo Res Green \$ 89.00
- Hi Res Green \$149.00

NEC:

- 1201 Green \$159.00
- 1212 Color Composite \$299.00
- 1203 RGB Hi-Res Color \$599.00

Zenith:

- ZVM-121 17MHZ \$109.00

Taxan:

- Amber \$145.00

Princeton Graphics:

- Outstanding color for IBM SCALL

MODEMS

D.C. Hayes:

- Micromodem II (Apple) \$259.00
- Smartmodem 300 Baud \$209.00
- Smartmodem 1200 Baud \$525.00
- Smartcom II \$ 85.00

Novation:

- J-Cat RS232 Direct Connect \$119.00
- Smart Cat 1200 Baud \$455.00
- Appletac II (Apple) \$289.00

**U.S. Robotics:

- 2 year warranty
- 300 Baud \$179.00
- 1200 Baud \$479.00
- Passport SCALL

DISKETTES

**Kangaroo:

The disks with the 'jump' on the competition. Outstanding value with library case and a ten year warranty.

- 5 1/4" SS/DD (Boxes of 10) \$21.95
- 5 1/4" DS/DD (Boxes of 10) \$30.95

*NEW! The '6-pak':

- 5 1/4" SS/DD (Boxes of 6) \$14.95
- 5 1/4" DS/DD (Boxes of 6) \$19.95

*Dysan—outstandingly low priced

- 5 1/4" SS/DD (Boxes of 10) \$31.95
- 5 1/4" DS/DD (Boxes of 10) \$39.95

Verbatim:

- 5 1/4" SS/DD (Boxes of 10) \$23.95
- 5 1/4" DS/DD (Boxes of 10) \$43.95

Elephant Diskettes:

- 5 1/4" SS/DD (Boxes of 10) \$22.95
- 5 1/4" DS/DD (Boxes of 10) \$29.95

PRODUCTS FOR THE APPLE® COMPUTER

MBI APPLETIME CARD

Works with DB Master and Visidex Mountain Computer mode.
Basic and pascal operation complete with datebook software \$ 79.00

MBI VIP CARD

Dual Port Parallel/Serial Graphics Card \$119.00
Use ASCII Express The Professional 4.0 to simultaneously transfer data
from modem to printer using the VIP Card.
ASCII Express (The Professional) \$ 99.00

WORD PROCESSING SPECIALS

Online:
Screenwriter \$CALL
The Professional \$CALL
Silicon Valley:
Format II \$CALL

APPLE SOFTWARE

Continental:
The Home Accountant ... \$ 54.00
Silicon Valley Systems:
Word Handler \$119.00
List Handler \$ 65.00
Stoneware:
DB Master \$159.00
DB Utility 1, 2, 3 ea. \$ 69.00
Visicorp:
Visicalc 3.3 \$185.00
Visifiles \$185.00
Visidex \$185.00
Visitrend/Plot \$229.00

Ram Cards:
Microsoft 16K \$ 79.00
CP/M for Apple:
Microsoft Z80 Card \$269.00
Advanced Logic \$CALL
Kensington System Saver . \$ 69.00
T & G:
Joysticks \$ 44.00
Select-A-Port \$ 44.00
Game Paddles \$ 29.00
Kraft:
Joysticks \$ 49.00
Game Paddles \$ 33.00
80 Column Cards:
Videx with Softswitch \$279.00

DRIVES FOR YOUR APPLE

Microsci:
A-40: High reliability with 40 data storage tracks \$CALL
A-70: Offers exactly twice the storage capacity of the Apple Disk II ... \$CALL
Fourth Dimension:
With Controller Card \$CALL
Without Controller Card \$CALL

Rana:
Elite I: 40 track \$CALL
Elite II: 80 track \$CALL
Elite III: 160 track \$CALL

For 24-hour/7 Days a Week Ordering & Product Information,
Call "**COMPU-LINE™**" our Computer Modem Line
1-303-279-4218

Product Information & Order Lines:
(303) 279-2848 or (800) 525-7877
Customer Service & Order Inquiry Line: (303) 278-8321
ORDER DEPARTMENT: 1019 8th St. • Golden, CO 80401

(full duplex, 300 baud)

Apple IIe®
Provides these standard features:
• Typewriter-style, full ASCII keyboard, upper and lower case, and auto-repeat feature.
• 6502A microprocessor (8-bit CPU)
• 64K bytes RAM memory
• 16K bytes ROM, which includes built-in Apple-soft BASIC language
• Color graphics and sound capabilities
• Seven I/O expansion slots
• Back panel designed for quick connect/disconnect, using D-style connectors \$CALL



Commodore 64: 'The personal computer with professional power'

Features:
• 64K RAM memory
• Typewriter style keyboard with 8 function keys
• Advanced color graphics
• Professional sound and music
• Two game ports \$CALL

NEW Columbia Portable Computer 'The very personal computer'

Featuring:
Fully IBM PC compatible
• 128K RAM
• 2, 5 1/4" half height drives
• 9" green or amber screen
• Thousands of dollars worth of free software \$CALL

NEC APC

NEC's finest business computer only available at our retail stores.



Columbia Data Products Personal Computer



Featuring:
• IBM PC Compatibility
• 16-bit 8088 Processor
• 8 Expansion Slots
• Two RS232 Serial Ports
• Centronics Printer Port
• Double Density Floppy Disk Controller
• 128K RAM Standard Memory
CALL FOR PRICING AND INFORMATION ON THE EXTENSIVE SOFTWARE STANDARD WITH THE COMPUTER!

IBM® Personal Computer

Features:
• 64K Memory
• 2 Tandon TM-100-2, 320K Byte Drives
• 1 floppy disk controller
• 1 color graphics card
SlimLine drives and hard disk drives configurations are available upon request.

Call for pricing on all IBM® Systems.

NOW CARRYING:

Panasonic JR-200:
ALL THIS BUILT IN:

- Color/Sound/Graphics
- 32K
- Auto repeat keys/Function keys/Separate cursor control pad
- Basic in ROM
- Much, much more

The Personal computer, extremely versatile \$299.00

Computer-Line is NOW OPEN 7 Days a Week!

Product Information & Order Lines

Mon.-Fri. 7 a.m. to 8 p.m.
Sat.-Sun. 8 a.m. to 6 p.m.
(Mountain Standard Time)

Franklin Ace 1000

Offers:
• 64K Memory
• 40 column upper/lower case display
• Apple IIe compatibility
• more space between expansion slots and internal fan aid cooling \$CALL

Call for prices on Franklin Ace 1200!

Write or Call for Our Comprehensive Catalog.

Call "THE COMPUTER-LINE"

Product Information & Order Lines: (303) 279-2848 or (800) 525-7877

Customer Service & Order Inquiry Line: (303) 278-8321

ORDER DEPARTMENT: COMPUTER-LINE, Inc. • 1019 8th Street • Golden, CO 80401

COMPUTER-LINE of Denver • 1136 So. Colorado Blvd. • Denver, CO 80222

Circle 103 on inquiry card.

Look for our "Computer-Line" Stores opening throughout the U.S. Write for our Franchise Package.



TERMS: All prices reflect a 2 9% cash discount. All goods acknowledged faulty on receipt by the customer will be repaired or replaced at our discretion. Customers must call for an RMA number before returning any goods. This facilitates our quick attendance to faulty goods. We reserve the right to repair or return to the manufacturer for repair at goods becoming faulty within the specified warranty period. Any goods (hardware or software) returned for restocking are subject to a 15% restocking fee at our discretion. The charge for cancellation of orders is 20% at our discretion. No returns on software. We accept no responsibility for any false claims made by manufacturers. Prices quoted for stock on hand and subject to change without notice. Specialists in APO and international deliveries. Please add 5% (minimum \$5.00) for shipping. APO add to all prices 2% for shipping (minimum \$3.00). Please allow 10 working days plus mail time (if an order is mailed in for receipt of all UPS delivered goods.

ALL BRANDS ARE REGISTERED TRADEMARKS

Listing 2: Two subroutines to convert floating-point numbers between IBM and 8087 internal formats.

```

0000
PAGE 08,132 ; Set page width to 132 columns
TITLE      - IBM/8087 Short-Real Conversion Routines
ASSUME CS:CODE
CODE SEGMENT
; This file can be assembled separately, and then linked with any other
; files that need the conversion routines
PUBLIC C_IBM_8087
C_IBM_8087 - routine to convert a "short-real number from IBM
to 8087 format
Inputs : Register BP points to the 4-byte "short-real"
value to be converted
Outputs: Converted value is written over original
At register contents destroyed
C_IBM_8087 PROC FAR
; Real numbers are stored least significant byte at lowest addr.
mov ax:[bp+2] ; get most significant 2-bytes
cld ax:[bp] ; test for "zero" value
jne CONT18H ; Skip if not zero and continue conversion
cld word ptr [bp],0 ; Check second word for zero
EXIT8H ; If all 4 bytes are zero, no conversion
CONT18H: dec ah ; subtract two from exponent
rcl ah,1 ; rotate sign bit into 8088 carry field
rcl ah,1 ; rotate sign bit into upper byte for 8087
; also rotates lowest bit into carry field
; rotate lowest bit of exponent into lower byte
; save new value back on top of original
rcl ah,1
EXIT18H: mov ret [bp+2],ax
C_IBM_8087 ENDP

0000
PAGE 08,132
TITLE      - IBM/8087 Short-Real Conversion Routines
ASSUME CS:CODE
CODE SEGMENT
; This function executes a FSTSW macro to get condition codes
; from 8087. Assumes user loaded "g" onto top of stack and
; then either loaded "A" and compared/tested or else compared/tested
; "A" from memory (ie. FCOMP A).
; Returns:
; 0 - A = B
; 1 - A > B
; 2 - A < B
; 3 - No Order between A and B
Register AX is destroyed
PUBLIC CW87
CW87 PROC FAR
; Status will be stored in this location
; Need to get address to stack
; Will use BP as address for store
; Get status of top of stack in memory
; Restore BP address
; Move status into register AX
; Load condition codes into CPU FLAG
; Use conditional jumps to determine ordering of A and B
; A_LESS_OR_UNORDERED OTHERWISE CF = CA = 0
; JNE A_GREATER ; JUMP IF A > B
A_EQUAL: mov al,0
jnp SHORT EXIT_CHK ;
A_GREATER: mov al,1
jnp SHORT EXIT_CHK ;
A_LESS_OR_UNORDERED:
jnc A_LESS ;
A_LESS: jne A_LESS ;
A_B_UNORDERED:
mov al,3
jnp SHORT EXIT_CHK ;
A_LESS: mov al,2 ;
EXIT_CHK: mov ah,0 ; upper byte of return value is zero
ret
CW87 ENDP
PAGE
; FUNCTION CW87: INTEGER;
; This function executes a FROM 8087 instruction which allows
; user to determine whether the value on the top of the 8087
; stack is positive or negative and either NaN (Not-a-Number),
; unnormal, denormal, normal or zero.
; Returns:
; None
; Inputs:
; None
; Outputs:
; Returns value 0 - 15 as function
; 0 : Unnormal
; 1 : NaN
; 2 : Unnormal
; 3 : NaN
; 4 : Normal
; 5 : Infinity
; 6 : Normal
; 7 : Infinity
; 8 : Zero
; 9 : Empty
; 10 : Zero
; 11 : Empty
; 12 : Denormal
; 13 : Empty
; 14 : Denormal
; 15 : Empty

```

Listing 3 continued on page 368

Listing 3: Four 8087 status-word utility programs.

```

0000
PAGE 08,132
TITLE      - 8087 Utility Programs
; Now, lets mail in the 8087 software support macros
ENDIF
ASSUME CS:CODE, DS:CODE
PUBLIC C_8087_IBM
C_8087_IBM - routine to convert a "short-real number from 8087
to IBM format
Inputs : Register BP points to the 4-byte "short-real"
value to be converted
Outputs: Converted value is written over original
At register contents destroyed
C_8087_IBM PROC FAR
; get most significant 2-bytes
mov ax:[bp+2]
; test for "zero" value
jnc CW87 ; Skip if not zero and continue conversion
; Check second word for zero
EXIT08H ; If all 4 bytes are zero, no conversion
CONT8087: rcl ah,1 ; rotate lowest exponent bit into carry field
rcl ah,1 ; move lowest exponent bit into upper byte and
; move sign bit into carry field at same time
; rotate sign bit into lower byte as needed
; add two to exponent
; save new value back on top of original
mov ret [bp+2],ax
C_8087_IBM ENDP
CODE ENDS
ENDP

```

Listing 3 continued on page 368

NOW \$649.00
Manufacturer's Suggested Retail Price

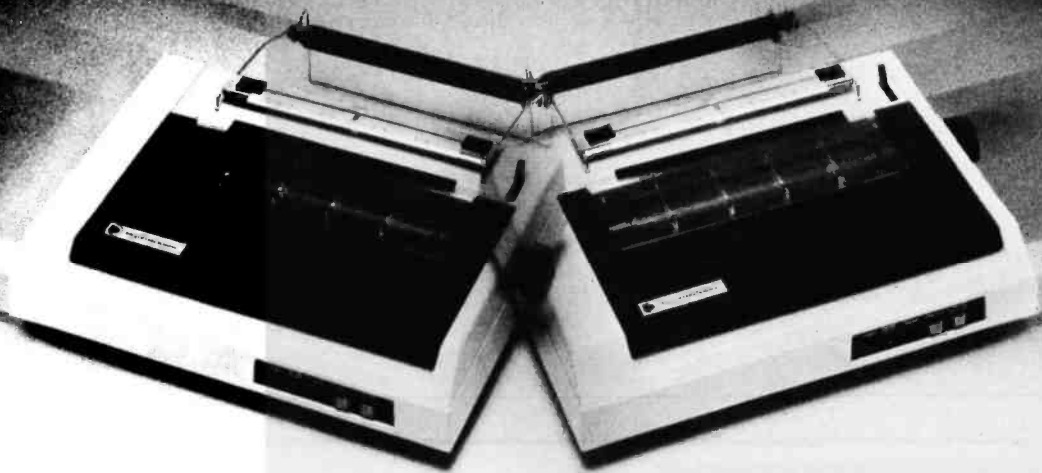

PRINTS LIKE A DAISY... COSTS LIKE A MATRIX.

Integral Data Systems introduces the only low-cost dot matrix printer on the market that features Maisey™ printing. Maisey printing is a technique that allows you to produce correspondence-quality text approaching that of more expensive daisy-wheel printers, but at much faster speeds.

How fast? With Microprism Printer's™ dual speed capability, you can output at 75cps in correspondence-quality and 110cps in high-speed data mode. And it also features sharp, high-density graphics in an 84 x 84 dpi format.

You'll get cleaner, crisper output than you ever thought possible in a single pass.

Other standard features of the Microprism include proportional

spacing, text justification and, of course, software compatibility with our more expensive Prism Printer™ line.

The Microprism Printer is the perfect system mate that can handle all of your printing requirements . . . it's the best of both worlds. So if you've been waiting for the price of daisy-wheel printers to come down, or the quality of dot matrix to go up, now is the time to check out the exciting new Microprism Printer from Integral Data Systems.

Stop in at your local dealer today and ask for a demonstration. If you need the name of the dealer nearest you, call us toll-free at (800)258-1386.

Or write Integral Data Systems, Milford, NH 03055.



MICROPRISM™



Integral Data Systems, Inc.

Microprism Printer, Prism Printer and Maisey are registered trademarks of Integral Data Systems, Milford, NH.

```

#022: 0022 06 E5      ; Execute EXAM operation on I05
PUBLIC EXAMB7
EXAMB7 PROC FAR
    FIRM
    * WAIT
    * ESC 2FH, (BP*2)
    ; Status will be stored in this location
    ; Need to get address to stack
    ; Will use BP as address for store
    ; Get status of top of stack in memory
    ; Restore BP address
    ; Moves status into register AX
    ; Put CS bit into bit 1
    ; Clear out all but CS bits
    ; Shift CS bit down to bit 1
    ; Put CS bit into bit 3
    ; Now AX contains proper status value
    RET
EXAMB7 ENDP
PAGE
; FUNCTION GETST : INTEGER
; This function gets current STACK TOP POINTER value from status
; word and returns it to user
; Inputs : None
; Outputs : Returns value @ - 7 as function
PUBLIC GETST
GETST PROC FAR
    PUSH AX
    PUSH BP
    PUSH SP
    FSTSW (BP*2)
    * WAIT
    * ESC 2FH, (BP*2)
    ; Status will be stored in this location
    ; Need to get address to stack
    ; Will use BP as address for store
    ; Get status of top of stack in memory
    ; Restore BP address
    ; Moves status into register AX
    ; Get stack top value in AH
    ; Mask out all but stack count
    ; Shift count to low three bits
    ;
    ; Restore BP address
    ; Moves status into register AX
    ; Get stack top value in AH
    ; Mask out all but stack count
    ; Shift count to low three bits
    ;
    RET
GETST ENDP
; FUNCTION STATUS : INTEGER
; This function gets current status bits from status
; word and returns it to user
; Inputs : None
; Outputs : Returns value @ - 255 as function
PUBLIC STATUS
STATUS PROC FAR
    PUSH AX
    PUSH BP
    PUSH SP
    FSTSW (BP*2)
    * WAIT
    * ESC 2FH, (BP*2)
    ; Status will be stored in this location
    ; Need to get address to stack
    ; Will use BP as address for store
    ; Get status in memory
    ; Restore BP address
    ; Moves status into register AX
    ; Clear out all but status bits
    ;
    RET
STATUS ENDP
CODE ENDS
END
    
```



Only \$499.95 plus shpg.

Closed. It's a handsome armoire

New! A solid wood Work Center as efficient as your computer

The Exeter, the complete computer work center, and also a tall, handsome cabinet which conceals work clutter! Finished cabinet is antique (dark) pine. 62" h x 32" w x 25 1/4" d. Also available unfinished in kit form.

- Fits most computers — IBM, Apple, TRS 80, etc.
- Paper tray below printer
- Pull-out shelves for computer keyboard and printer
- Adjustable/removable shelf for CRT

Call toll-free: 1-800-258-4720

In New Hampshire: 1-800-552-0320

Visa, MasterCard, American Express



Quality pine furniture for over 35 years
Dept. BY38, North Conway, N.H. 03860

- Please send the Exeter Computer Work Center. Enclosed is \$499.95 plus \$50.00 shipping. (Requires minor assembly)
- Please send the easy-to-build unfinished Exeter kit. Enclosed is \$349.95 plus \$35.00 shipping.
- Please send free additional information.

Name (please print)

Address

City State Zip

YOU WANTED TO BE THE BOSS.

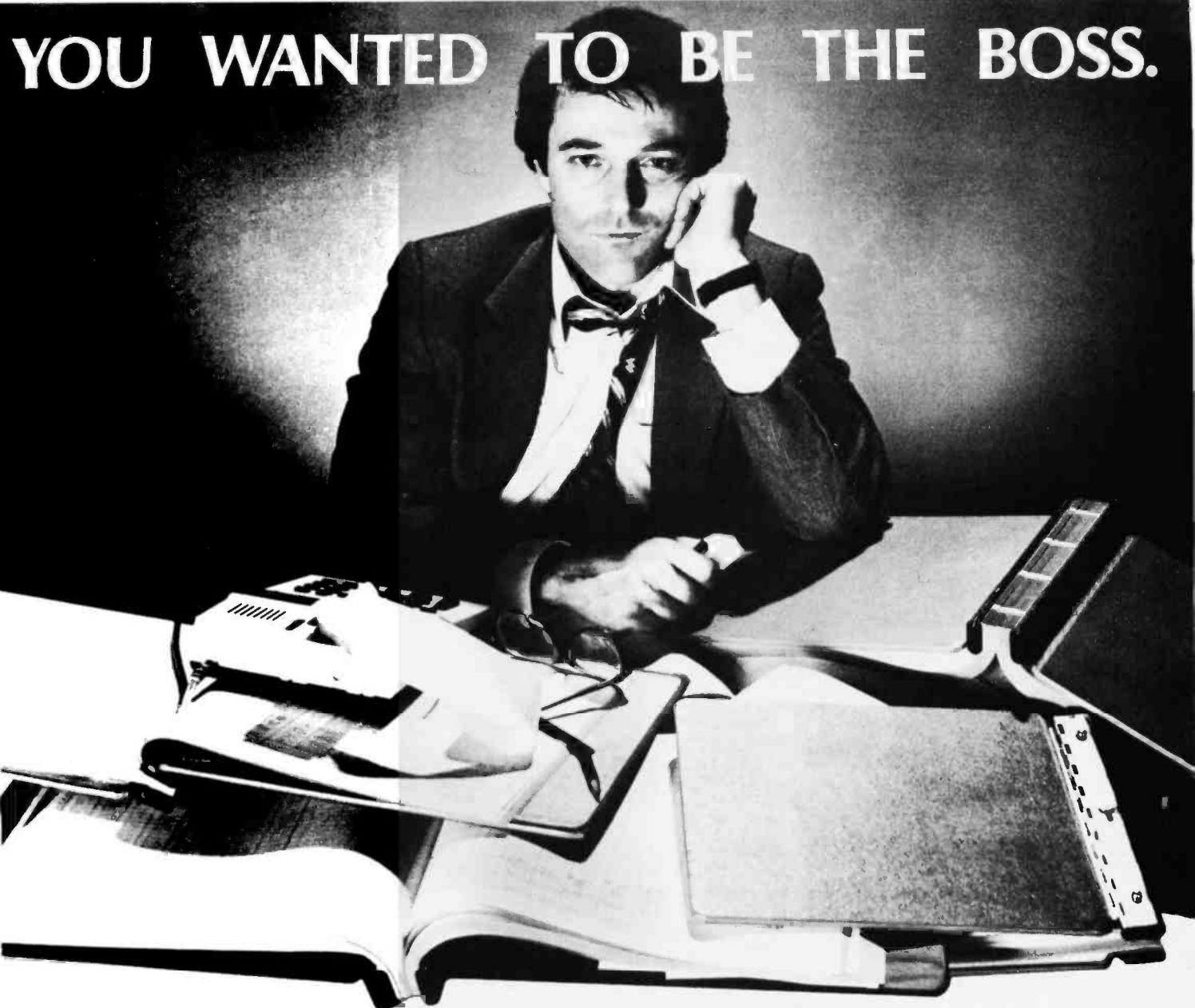

YOUR QUARTERLY TAXES ARE DUE ON FRIDAY, BUT YOU'RE STILL DOING LAST WEEK'S PAYROLL.

Today, even the greatest entrepreneur can feel that he works for everybody but himself—the IRS, the landlord, the banker, even the janitor.

WITH THE BOSS, YOU'RE THE BOSS AGAIN.

Business and computer experts agree the key to solving your business problems is the choice of software. Hardware equipment selection is second.

To be competitive today means handling large amounts of information quickly. To be on top tomorrow means managing much, much more.

The Boss Business Software Products are comprehensive business software programs which get you information you need, as you need it, when you need it and the way you need it. *You know your financial picture at every moment.* You don't have to wait to close out the books at the end of every month.

The Boss takes care of all your business needs, your financial accounting, payroll, inventory and time billing.

WITH THE BOSS, YOU'RE THE BOSS AGAIN.

The Boss Business Software Products are compatible with most hardware systems. Call Balcones Computer Corporation to learn more about making yourself the Boss again.

Circle 42 on inquiry card.

YES, Send me more information on The Boss.

NAME _____

COMPANY _____

ADDRESS _____

CITY _____ STATE _____ ZIP _____

PHONE _____

TYPE OF BUSINESS _____

For more information call toll free: 1-800-531-5483.

In Texas call toll free: 1-800-252-8184.

Balcones Computer Corporation
5910 Courtyard Drive
Austin, Texas 78731

THE BOSS BUSINESS SOFTWARE PRODUCTS



SOMEWHERE, OUT THERE, A BEST-SELLING PROGRAM

WHERE IS IT?

Wherever it is, we want it. Maybe, just maybe, we're searching for your program, but we'll never find it unless you call us.

It has to be good, though. Because we're the Software Guild™, an organization devoted to finding the very best microcomputer programs for packaging and distribution under the Softsmith™ label. Hundreds of titles have already been licensed to the Softsmith library. But they're only the beginning. Our goal is to have the best program in major categories on every

popular machine. Of course, we can't do it without you.

If you're a program author or publisher, The Software Guild offers some distinct professional and monetary advantages.

First, you devote your time to what you do best: programming. You can leave the manufacturing, packaging, documentation, distribution and customer service to us.

Second, our revolutionary retail merchandising system will put your program before the public through the normal computer and software stores, plus record outlets, department stores, book shops, and more places where software has never before been available.

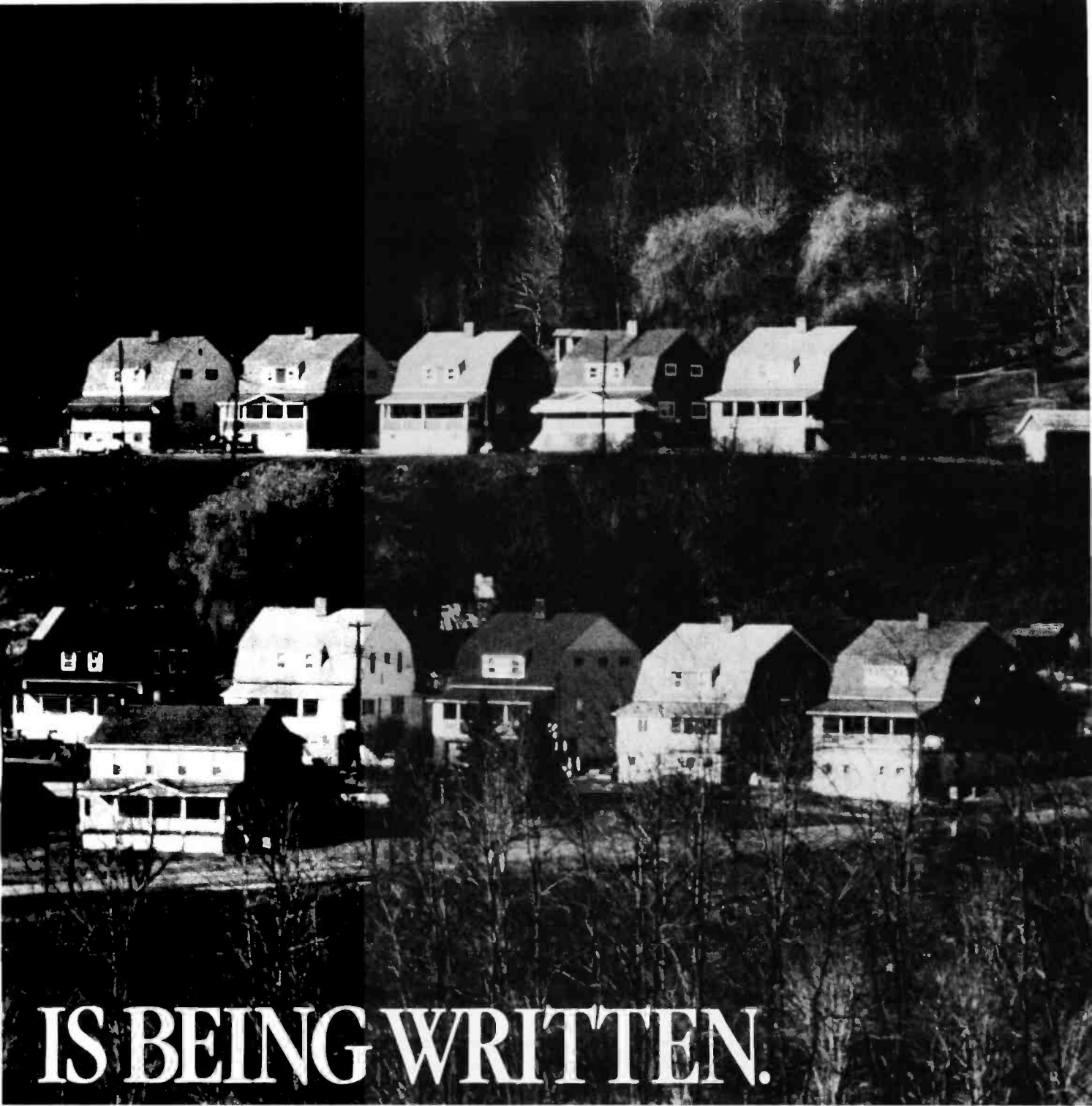

IS BEING WRITTEN.

Third, is royalties. Wider distribution means more substantial royalties. And, your Software Guild royalties start to accrue when the dealer makes his purchase in quantity, so you aren't left waiting while money trickles in.

Fourth is flexibility. We do not insist on the exclusive rights to your program. You can deal with other publishers and distributors, or market your program yourself, while it is in Softsmith distribution.

We know you're out there, working and dreaming, and we want to help make your dream come true. Our full staff of professional evaluators are waiting to review your best-seller.

So call us, wherever you are.

Contact Regina Roberts at (415) 487-5200.

Or write:

**The Software Guild
2935 Whipple Rd.
Union City, CA 94587**



The Software Guild™
(415)487-5200

8087 Status-Word Utilities

The 8087 comparison operations look at the top stack element within the 8087 and compare it with some other operand or test it (i.e., implicitly compare the top-of-stack with 0.0). The 8087 has an internal status word that can be accessed (via the FSTSW "store status word" instruction) by the 8088 CPU to determine the results of the comparison operations. The 8087 status word reflects the overall condition of the chip.

It should be made clear at this point that the 8087 NDP and 8088 CPU do not share registers. You cannot move the contents of an 8088 register directly to the 8087 stack or vice versa. To move a value from an internal 8088 register (perhaps containing a 16-bit word-integer), you must move that value into some temporary location in memory and then load it into the 8087. To examine the internal status of the 8087, you must store the status word into memory using the FSTSW operation, then move it into the 8088 CPU internal registers for testing.

The main use of the status word is for conditional branching (i.e., to test a register or registers and branch to a certain code depending on the value of the register or the comparison of two registers). Table 2 shows the different inter-

pretations of the 8087 condition-code bits of the status word for the three comparison instructions; NAN means "not a (valid) number." Condition-code bits C0 through C3 are bits 8, 9, 10, and 14 of the status word.

Listing 3 contains four subroutines that provide access to the 8087 status word and return to the user some indication of the internal state of the 8087. These routines are a great help in debugging programs during software development because they provide a "peek" into the 8087.

The first of the four routines, CHK87, is designed to be executed immediately after an 8087 test or comparison operation is executed (see FTST and the FCOM variations of instructions in table 1). This routine will return an indication of whether the comparison/test returned "equal to," "greater than," "less than," or "no order." The condition-code bits C0 and C3 from the 8087 status word are used as defined in tables 2a and 2b to determine these results.

The EXAM87 routine executes the 8087 FXAM instruction, which examines the top stack element. The 4 condition-code bits (C0 to C3) in the status word are set according to the rules set out in table 2c. EXAM87 returns the value (0 to 15) under this interpretation of the condition codes.

(2a)			(2c)				
C3	C0	Result	C3	C2	C1	C0	Interpretation
(Bit 14)	(Bit 8)		(Bit 14)	(Bit 10)	(Bit 9)	(Bit 8)	
0	0	ST is positive and nonzero	0	0	0	0	+ Unnormal
0	1	ST is negative and nonzero	0	0	0	1	+ NAN
1	0	ST is zero (+ or -)	0	0	1	0	- Unnormal
1	1	ST is not comparable (i.e., it is a NAN or projective ∞)	0	0	1	1	- NAN
(2b)			0	1	0	0	+ Normal
C3	C0	Order	0	1	0	1	+ ∞
(Bit 14)	(Bit 8)		0	1	1	0	- Normal
0	0	ST > source	0	1	1	1	- ∞
0	1	ST < source	1	0	0	0	+ 0
1	0	ST = source	1	0	0	1	Empty
1	1	ST?source	1	0	1	0	- 0
			1	1	0	1	Empty
			1	1	1	0	+ Denormal
			1	1	1	1	Empty
			1	1	1	0	- Denormal
			1	1	1	1	Empty

Table 2: The 8087 condition codes and their interpretations. Each bit is described in terms of its position within the 8087 status word.

Text continued from page 362:

The rest, explained in the text box "8087 Status-Word Utilities" and given in listing 3, give four needed utility routines that let the 8088 CPU interact with the 8087 status register.

Some things can be done to M8087 to speed up its use. First, avoid entering all the comments found in listing 1 into the M8087.MAC file. This saves both disk space and a great deal of assembly time (comment lines slow down the assembler). I have included fairly detailed comments in listing 1 for the reader's sake. The version I actually use has had all the comments removed for maximum performance.

Another way to speed up M8087 is to remove the

lowercase support features included in the CHECK_ST, CHOOSE_4, and INT_SIZE macros. For every operand memory type and "ST" use, these macros check for lowercase and uppercase versions of the same string. This is a nice feature, but it does cost in assembly time.

Implementing the above suggestions cuts the disk file size of M8087 from around 20K bytes to 6K bytes. The speedup of the reduced file is dependent on the percentage of instructions in the program that are 8087 operations, but the above modifications can cut assembly time by as much as half.

The IBM Macro Assembler recognizes the "real" constant type. It lets you include a value in decimal scientific

Sell Your Software TO MAJOR PUBLISHERS!

Would you like the opportunity to discuss your software or software development skills with major publishers looking for product and development assistance, venture capitalists looking for investment opportunities and agents looking for software developers? At The Great American Software Contest you can do all that and compete for prizes worth up to \$10,000 at the same time!

In addition, you'll spend the day before the exhibit in seminars with software market analysts from TALMIS—the same people consulted by IBM, Atari and other major companies for information and advice. They'll tell you what it will take to sell software yourself; how you might work with an agent; what publishers and venture capitalists are looking for; what to watch out for when negotiating contracts, how the software market is changing and more important selling tips.

We've tried to make this conference as inexpensive for you as possible. You won't need any fancy booth or signs. Curtained booths are available for those with top-secret programs. Just bring yourself, your micro-computer and your unpublished software. The cost for you to compete for prizes up to \$10,000, learn the ropes of software selling and discuss your products or talents with publishers, agents and venture capitalists is \$195 plus \$15 for electricity (that's less than it costs us.) Special hotel rates are available.

Space is limited so call today to enter The TALMIS/InfoWorld Great American Software Contest. And get busy on that software—the publishers are waiting for you! For more details contact Master Plans Conference Management, 111 E. Chestnut St., Suite 24F, Chicago, IL 60611: (312) 944-1711.

Enter
**THE GREAT
AMERICAN
SOFTWARE
CONTEST**

Nov. 1-2

Boston Park Plaza
Boston, MA

One \$10,000 Grand Prize
Five \$3000 First Prizes in category
Five \$500 Second Prizes in category
Ten \$250 Third Prizes in category

+ \$30,000 IN PRIZES

More on the 8087

For more information on the 8087 and how it works, see the text boxes in this article, the article "The Intel 8087 Numerics Processor Extension" (April 1983 BYTE, page 154—in particular, see the text box on 8087 binary arithmetic on pages 174 and 175), and Intel Corporation's Numerics Supplement to the 8086 Family User's Guide. For more information, contact the source below.

M8087 on Disk

A disk containing both commented and uncommented versions of the M8087 macro file is available on a standard IBM single-density format 5¼-inch floppy disk. For more information, contact

Field Computer Products
909 North San Antonio Rd.
Los Altos, CA 94022
(415) 949-3457

notation such as "27.24E-2" in your program. It assembles this into a 32-bit IBM-format binary real number. This is a handy feature and, when used with the conversion routines from listing 1, can be used in 8087-based computations.

The main task remaining for an assembly-language programmer wishing to use the 8087 is to write a couple of routines that will convert real numbers into their

ASCII (American National Standard Code for Information Interchange) equivalents (and vice versa). This will let you enter and display real variables from an assembly-language program. An Intel application note (#AP-113, "Getting Started With the Numeric Data Processor") has assembly-language routines to do these and other tasks.

Final Notes

The bottom line to M8087 is "Is it worth the cost in assembly time?" For myself the answer is a hearty *yes*. If using it increased the running time of a program, my answer would be different. But a slowdown in assembly time is a small price to pay for not having to hand-assemble each 8087 instruction into its escape sequence.

We have seen what the Intel 8087 NDP is, what it can do, how it fits into the IBM Personal Computer, and how we can provide software support for the assembly-language programmer using the 8087 in the IBM PC. Next month, we will see how to provide higher-level support so that Pascal users can access the 8087. ■

Acknowledgment

I would like to thank Brian Van Herp of Intel in Indianapolis for his assistance.

Tim Field (909 North San Antonio Rd., Los Altos, CA 94022) has a master's degree in computer science from Purdue University. His experience includes several years' work at Digital Equipment Corp.

BYTE back issues for sale

	1976	1977	1978	1979	1980	1981	1982	1983
Jan.				\$2.75	\$3.25	\$3.25		\$3.70
Feb.			\$2.75	\$2.75	\$3.25	\$3.25	\$3.70	\$3.70
March			\$2.75	\$2.75	\$3.25	\$3.25	\$3.70	\$3.70
April			\$2.75	\$2.75	\$3.25	\$3.25	\$3.70	\$3.70
May		\$2.00	\$2.75	\$2.75	\$3.25	\$3.25	\$3.70	\$3.70
June		\$2.00	\$2.75	\$2.75	\$3.25	\$3.25	\$3.70	\$3.70

	1976	1977	1978	1979	1980	1981	1982	1983
July	\$2.00	\$2.00	\$2.75	\$2.75	\$3.25	\$3.25	\$3.70	\$4.25
Aug.		\$2.00	\$2.75	\$2.75		\$3.25	\$3.70	
Sept.		\$2.75	\$2.75	\$2.75	\$3.25	\$3.25	\$3.70	
Oct.			\$2.75	\$2.75	\$3.25	\$3.25		
Nov.		\$2.75		\$3.25	\$3.25	\$3.25	\$3.70	
Dec.	\$2.00	\$2.75	\$2.75	\$3.25	\$3.25	\$3.25	\$3.70	

Circle and send requests with payment to:
BYTE Back Issues
P.O. Box 328
Hancock, NH 03449

Please allow 4 weeks for domestic delivery and 8 weeks for foreign delivery.

name _____
address _____
city _____
state _____ zip _____

The above prices include postage in the US. Please add \$.50 per copy for Canada and Mexico; and \$2.00 per copy to foreign countries.

Check enclosed

Payments from foreign countries must be made in US funds payable at a US bank.

VISA Master Card
Card # _____ Exp. _____

Signature _____

THE BUSINESS MANAGER™

A complete software solution
packaged on hard disk for the IBM® PC

GENERAL LEDGER

ACCOUNTS RECEIVABLE

BILLING

INVENTORY

ACCOUNTS PAYABLE

PAYROLL

WORD PROCESSOR - WORDSTAR™

SPELLING CHECKER - SPELLSTAR™

FILE MANAGEMENT - MAILMERGE™

ELECTRONIC SPREADSHEET - REPORT MANAGER™

Application generator plus 3-dimensional spreadsheet w/graphics

RELATIONAL DATABASE MANAGEMENT SYSTEM

MicroRIM™ (True mainframe capabilities)

- ★ All software installed on hard disk, initialized and ready to run.
- ★ Fully menu driven operating environment.
- ★ General Ledger comes with a chart of accounts and is fully interactive with Accounts Receivable, Billing, Inventory, Accounts Payable and Payroll.
- ★ Data may be directly transferred between MicroRIM, Report Manager and Wordstar.
- ★ Unlimited free phone consultation to dealers.
- ★ 90 days free phone consultation to end users.
- ★ 1 year warranty on all hardware.

THE BUSINESS MANAGER™

1420 E. Edinger Ave., Suite 115, Santa Ana, CA 92705
(714)836-3560

IBM is a Reg. trademark of IBM Corp. Wordstar, Spellstar and Mailmerge are Reg. trademarks of MicroPro International. Report Manager is a Reg. trademark of Datamension Corp. Prices and specifications subject to change without notice.

Circle 54 on inquiry card.
www.americanradiohistory.com

ATTENTION DEALERS:
Call today to find out more
about our dealer program

DESK-TOP COMPUTING AT A PORTABLE PRICE.



What price portability? If you're looking for value in a computer, you've probably been thinking portable. Think again. How many portables have you seen in the airport? On the elevator? How about waiting for a bus? Maybe portability isn't the issue at all. Maybe what you're really looking for is a good, inexpensive answer to your computing problems. Without the limitations of a portable computer.

A simple solution. The Morrow Micro Decision™. A complete, *desk-top* business computer system with all the hardware and software of the most popular portable: Including a full size easy-to-read 12" display

screen that portables will never be able to match. And the price? As little as \$1590. Complete.

Expand your options. The Micro Decision is more than just one product; it's a product line. With complete systems, including software, from \$1590 to \$2490. And Morrow letter quality printers starting at \$595. Whether you need more hardware, more software, or more system, Morrow gives you more. For less.

Computing without compromise. If you're a business person looking for a real computer, call us at (800) 521-3493. We'll show you desk-top computing at a price you can handle.

EVERY MICRO DECISION COMES WITH:

Hardware: Z80CPU, a parallel and 2 serial ports, 64K RAM, full size smart terminal with detachable keyboard, multiple disk formats, menu-driven front end for CP/M.

Software: CP/M 2.2 Operating System, WordStar word processing with spelling checker, LogiCalc spreadsheet, MBASIC 80, BAZIC, Pilot programming languages.

Model MD1

One SSSD disk drive (200 Kbytes)
\$1590

Model MD2

Two SSSD disk drives (400 Kbytes total)
+
Personal PEARL DBMS
\$1990

Model MD3

Two DSDD disk drives (768 Kbytes total)
+
Personal PEARL DBMS
QUEST Bookkeeper*
\$2490

*\$37.50 license fee required

Micro Decision is a trademark of Morrow

MORROW

The Independent Business Computer

600 McCormick Street, San Leandro, CA 95477

(800) 521-3493 (415) 430-1970 In California

Circle 278 on inquiry card.

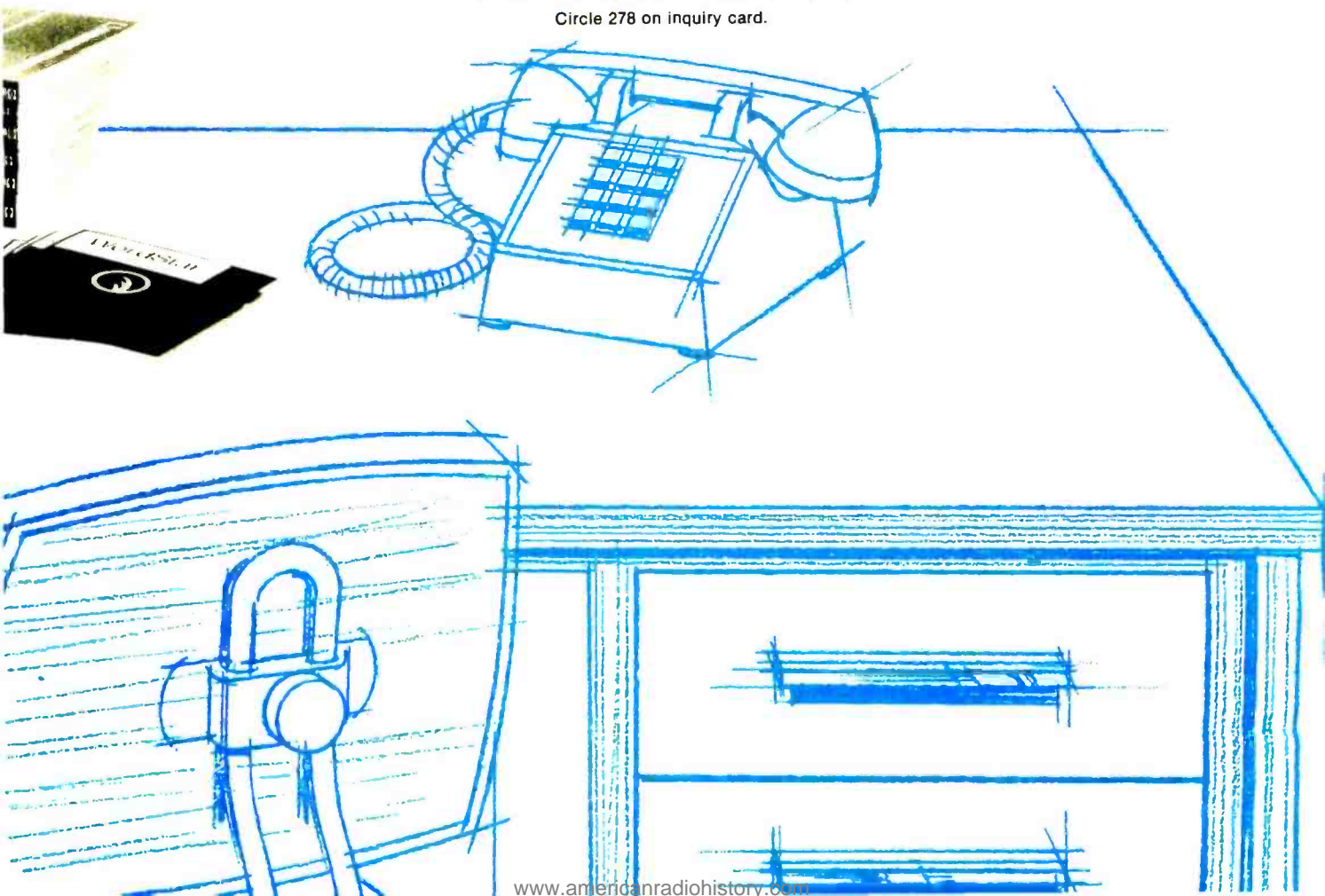

Cross-Reference Utility for IBM PC BASIC Programs

by James A. Folts

After struggling to debug a BASIC program, I finally discovered that my problem was a misspelled variable name in one line. To BASIC, CLRCR and CLRSCR are as different as black and white. To me, after staring at a monitor screen for over three hours, the difference wasn't so obvious. A cross-reference listing that organizes all labels (variable names) with their corresponding locations (line numbers) would provide a handy clue to spelling errors.

In the cross-reference listing, the misspelled variable becomes obvious because in most cases the correct name corresponds to several line numbers while the misspelled version has only a single reference. Although it is possible to define a variable and never use it again, the chances of that are slight enough to make this procedure a useful way to discover spelling errors.

The cross-reference listing also lets you change variable names systematically, check for conflicting or matching variable names before you merge two programs, and locate all the program lines that call a certain subroutine. With all of these applications, a cross-reference listing becomes a valuable tool for program development, debugging, and documentation.

The Program

To produce a cross-reference listing for BASIC programs running on the IBM Personal Computer, I wrote a program (see listing 1) that scans a BASIC program file and builds a list of variable names and the locations where they occur. The program then sorts that list and writes it to a file. Listing 2 shows a sample run, which is a cross-reference listing for the program itself.

The program expects a standard BASIC program file, that is, one saved without the special A (ASCII—American National Standard Code for Information Interchange) or P (protect) options. The standard save procedure stores the program in a tokenized format in which all reserved BASIC words are represented by tokens, 1- or 2-byte codes. For instance, the RANDOMIZE statement is represented by a single ASCII value of 185. This tokenized format saves space because multiple-character reserved words are represented by only one or two characters.

All tokenized characters have a value of 128 or greater, outside the range of ASCII values legal in variable names. Only capital letters, numerals, and the period are legal in variable names, and these have values between 46 and 90. (Variables can be entered in lowercase, but BASIC converts them to capitals.) The restrictions on legal variable names simplify the work of the cross-reference program because it can usually just skip tokens in its search for valid variable names. Two exceptions are the tokens for a remark (ASCII 143) or data statement (ASCII 132). In both these cases the program skips to the end of the line so as not to confuse words in remarks, or literals in data statements, with valid variable names.

All numbers used in a program—constants, initial values, line-number references, and so on—are also encoded. For instance, an ASCII 28 code indicates that an integer value follows in the next 2 bytes in the file. An ASCII 29 indicates a single-precision number in the next 4 bytes. Other prefixes indicate various types of double-precision numbers, octal numbers, or hexadecimal numbers.

Text continued on page 384

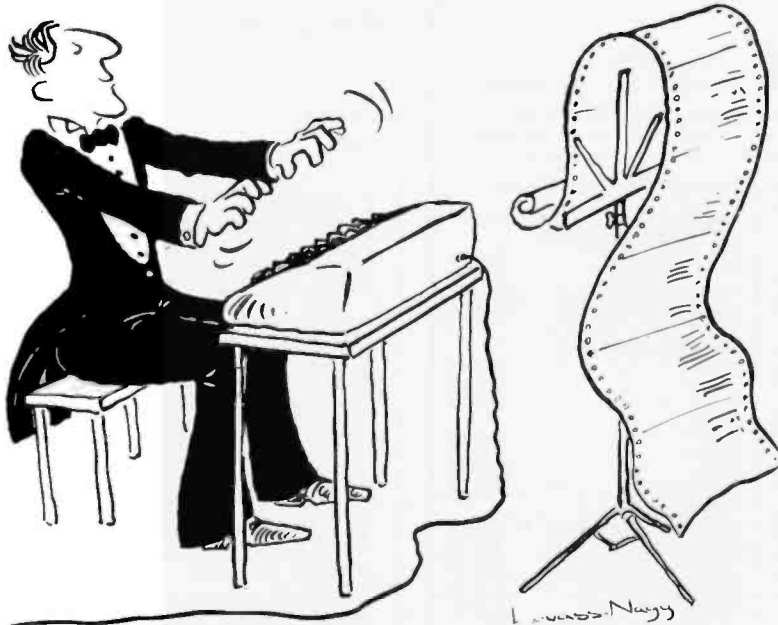

The Well-Tempered Cross-Assembler

Before Johann Sebastian Bach developed a new method of tuning, you had to change instruments practically every time you wanted to change keys. Very difficult.

Before Avocet introduced its family of cross-assemblers, developing micro-processor software was much the same. You needed a separate development system for practically every type of processor. Very difficult and very expensive.

But with Avocet's cross-assemblers, a single computer can develop software for virtually any microprocessor! Does that put us in a league with Bach? You decide

Development Tools That Work

Avocet cross-assemblers are fast, reliable and user-proven in over 3 years of actual use. Ask NASA, IBM, XEROX or the hundreds of other organizations that use them. Every time you see a new microprocessor-based product, there's a good chance it was developed with Avocet cross-assemblers.

Avocet cross-assemblers are easy to use. They run on any computer with CP/M* and process assembly language for the most popular microprocessor families.

XASMO5	6805	
XASMO9	6809	
XASM18	1802	
XASM48	8048/8041	
XASM51	8051	
XASM65	6502	
XASM68	6800/01	
XASMF8	F8/3870	
XASMZ8	Z8	
XASM400	COP400	
XASM75	NEC 7500	\$500

(Coming soon: XASM68K 68000)

\$200
each

Turn Your Computer Into A Complete Development System

Of course, there's more. Avocet has the tools you need from start to finish to enter, assemble and test your software and finally cast it in EPROM:

Text Editor VEDIT -- full-screen text editor by CompuView. Makes source code entry a snap. Full-screen text editing, plus TECO-like macro facility for repetitive tasks. Pre-configured for over 40 terminals and personal computers as well as in user-configurable form.

CP/M-80 version \$150
CP/M-86 or MDOS version \$195
(when ordered with any Avocet product)

ROM Simulator -- ROMSIM by Inner Access eliminates need to erase and reprogram EPROM. Installed in an S-100 host, ROMSIM substitutes RAM for EPROM in external target system. 16K memory can be configured to simulate the 2708, 2758, 2716, 2516, 2732, 2532, 2764, 2564 in either byte or word organization. Avocet's configurable driver makes loading of HEX or COM files fast and easy.

From \$495 depending on cabling and RAM installed.

EPROM Programmer -- Model 7128 EPROM Programmer by GTek programs most EPROMS without the need for personality modules. Self-contained power supply ... accepts ASCII commands and data from any computer through RS 232 serial interface. Cross-assembler hex object files can be down-loaded directly. Commands include verify and read, as well as partial programming.

PROM types supported: 2508, 2758, 2516, 2716, 2532, 2732, 2732A, 27C32, MCM8766, 2564, 2764, 27C64, 27128, 8748, 8741, 8749, 8742, 8751, 8755, plus Seeq and Xicor EEPROMS.

(Upgrade kits will be available for new PROM types as they are introduced.)

Programmer \$389
Options include:
Software Driver Package \$ 30
RS 232 Cable \$ 30
8748 family socket adaptor \$ 98
8751 family socket adaptor \$174

Call Us

If you're thinking about development systems, call us for some straight talk. If we don't have what you need, we'll help you find out who does. If you like, we'll even talk about Bach.

VISA and Mastercard accepted. All popular disc formats now available -- please specify. Prices do not include shipping and handling -- call for exact quotes. OEM INQUIRIES INVITED.

*Trademark of Digital Research.



**AVOCET
SYSTEMS INC.**

DEPT. 883-B
804 SOUTH STATE STREET
DOVER, DELAWARE 19901
302-734-0151 TLX 467210

PC Tech

Home & Business Computers
Products Sales & Services

We Shop The Wholesale Market And Negotiate The Best Price For You.
We Save You Off The List Price. We Share A Common Goal - To Save You Money.

Apple II Compatible 48K Computer Drive/Controller & Monitor ..	\$949.00
Kaypro II Computer Complete System	\$1679.00
*DISK DRIVES	
Mitac Drive 100% Apple Compatible w/case cable (dealers invited)	\$219.00
Controller Card	\$69.00
16K Memory Card	\$59.00
Z80 Card	\$109.00
80 Column Card	\$115.00
TM100-2 DS/DD	\$239.00
TM100-4 DS/DD	\$349.00
TM55-2 Half Height DS/DD	\$229.00
TM55-4	\$289.00
TM848-1 SS/DD	\$399.00
TM848-2 DS/DD	\$479.00
*WINCHESTER	
5MB For External	\$1379.00
10MB For External	\$1599.00
15MB For External	\$1789.00
5-1/4" Slim Line Single Drive	\$235.00
Dual Drives	\$349.00
*AST COMBO CARD	
Combo Plus - 256K Parallel & Serial Port, Clock Calendar W/Battery Back-Up W/Super Spool, Super Drive	\$489.00
Mega Plus - 512K Parallel & Serial Port, Clock Calendar W/Battery Back-Up W/Super Spool, Super Drive	\$989.00

Franklin Ace 1000 .. call for best price	
Columbia MPC Computer System .. call for best price	
*MAYNARD ELECTRONICS	
Floppy Disk Controller	\$169.00
FDC W/Parallel Port	\$219.00
FDC W/Serial Port	\$229.00
Memory Card W/256K RAM	\$489.00
*PRINTERS	
BROTHER D/W	
HR-1A P	\$759.00
HR-1A S	\$859.00
Tractor	\$129.00
EPSON	
MX80FT	\$469.00
FX80FT	\$569.00
MX100FT	\$669.00
FX100FT	\$769.00
*MONITORS	
BMC BM-12 AU 12" Green	\$89.00
BMC BM-12 AU 12" Amber	\$99.00
BMC BM-1401RGB W/Cd Cbl.	\$399.00
DYNAX GM-120 GM 12"	\$139.00
DYNAX AM-121 AM 12"	\$149.00
TAXAN KG-12N 12" Green	\$149.00
TAXAN KG-12N 12" Amber	\$149.00
TAXAN RGB 112"	\$365.00
AMDEX 12" Green #300	\$159.00
AMDEX 12" Amber #300	\$159.00
COMREX CR 5500-12" Green	\$79.00
COMREX CR 6500-12" Comp.	\$229.00
COMREX CR 6600-12" RGB	\$419.00

Many More Not Listed

PC Tech (714) 546-3887

3742 W. Warner Ave., Santa Ana, CA 92704

Disc Drive Service Available At Low Cost - Quick Turn-around
ADD SHIPPING CHARGES

Telephone or Mail Orders Please - Cashier's Checks, Money Orders, Checks (Allow 10 days).
COD Accepted. CA Residents Add 6% Sales Tax. Prices Subject To Change Without Notice.

Programming Quickies

Listing 1: Source code for cross-reference utility, written in IBM PC BASIC.

```

1 REM*****
2 REM
3 REM      CROSS-REFERENCE LISTING UTILITY FOR BASIC PROGRAMS
4 REM      FOR THE IBM PERSONAL COMPUTER
5 REM      By James A. Foits
6 REM
7 REM      This program reads a tokenized BASIC program file, finds and sorts
8 REM      all variable names and line references, and lists them on a disk
9 REM      file. Each name and line reference is cross-referenced to the
10 REM      line where it appears.
11 REM
12 REM      IBM PC BASIC                                JUNE 26, 1982
13 REM
14 REM*****
15 REM
16 REM*****
100 REM***** INITIALIZATION AND DEFINITIONS *****
110 DIM LABEL$(500), LINE.REF$(500), C$(128)
120 LABEL.NUMBER = 0 : FALSE=0 : TRUE=NOT FALSE : POINTER=129
130 REM
200 REM***** GET FILE NAME OF BASIC PROGRAM *****
210 CLS : KEY OFF : PRINT "BASIC CROSS REFERENCE GENERATOR" : PRINT
220 INPUT "ENTER FILE NAME: ", FILENAME$ : PRINT
230 OPEN FILENAME$ AS #1 LEN=128
240 REM
300 REM***** INITIALIZE INPUT FILE *****
310 FOR I=1 TO 128
320   FILE# 1, (I-1) AS X$, 1 AS C$(I) 'set up file buffer as an array
                                     'of 128 single characters
330 NEXT I
340 REM
400 REM***** READ FIRST THREE CHARACTERS OF BASIC PROGRAM FILE *****
420 GOSUB 7000 : IF C<>255 THEN PRINT "NOT A TOKENIZED PROGRAM FILE" : END
430 GOSUB 4000 'subroutine to get value for BASIC's offset address
440 REM
500 REM***** CONTINUE READING THE FILE: FILL ARRAYS LABEL$ AND LINE$ *****
510 REM***** WITH VARIABLE NAMES AND LINE NUMBERS *****
520 WHILE ADR<>0 'ADR=0 indicates end of program file
530   REM***** GET LINE NUMBER (A TWO-BYTE INTEGER VALUE) *****
540   GOSUB 7000 : LOW.BYTE = C
550   GOSUB 7000 : HIGH.BYTE = C
560   LINE.NO$ = (HIGH.BYTE * 256) + LOW.BYTE
570   LOCATE 10,1 : PRINT "PROCESSING LINE NUMBER"; LINE.NO$;
580   GOSUB 7000 'get first character after line number
590   REM***** NOW READ REST OF LINE *****
600   WHILE C<>0 'C=0 indicates end of line
610     IF C=143 OR C=132 THEN WHILE C<>0 : GOSUB 7000 : WEND : GOTO 720
                                     'mark or data statement--skip to end of line
620     IF C=209 THEN LABEL.NUMBER=LABEL.NUMBER+1 : LABEL$(LABEL.NUMBER)=
                                     "FN" : GOSUB 5030 : GOTO 720 'get user-def function name
630     IF C>127 GOTO 710 'skip any other tokens
640     IF (C>64 AND C<91) THEN GOSUB 5000 : GOTO 720 'get variable name
650     IF C=14 THEN GOSUB 6000 : GOTO 720 'get line number reference
660     IF C=34 THEN GOSUB 7000 : WHILE C<>34 AND C<>0 : GOSUB 7000 :
                                     WEND : IF C=0 GOTO 720 : GOTO 710 'skip string constant
670     IF C=15 THEN GOSUB 7000 : GOTO 710 'skip one-byte number
680     IF (C>10 AND C<14) OR C=28 THEN GOSUB 7000 : GOSUB 7000 : GOTO 710
                                     'skip two-byte number that follows
690     IF C=29 THEN FOR I=1 TO 4 : GOSUB 7000 : NEXT I : GOTO 710
                                     'skip four-byte number
700     IF C=31 THEN FOR I=1 TO 8 : GOSUB 7000 : NEXT I : GOTO 710
                                     'skip 8-byte number
710     GOSUB 7000
720   WEND
730   GOSUB 4000 'begin new line; get next value for offset address
740 WEND
750 REM
800 REM***** SORT LABELS AND LINE NUMBERS *****
810 LOCATE 12,1 : PRINT "PROCESSING COMPLETE . . ."
820 PASS=0
830 G%=LABEL.NUMBER
840 PASSES=INT(LOG(G%)/LOG(2))
850 WHILE G%>1
860   PASS=PASS+1
870   LOCATE 14,1:PRINT "SORTING: PASS ";PASS;" OF ";PASSES;" PASSES";
880   SORTED=FALSE
890   G%=G%\2
900   WHILE NOT SORTED
910     SORTED=TRUE
920     FOR I=1 TO LABEL.NUMBER-G%
930       IG%=I+G%
940       IF LABEL$(I)<LABEL$(IG%) GOTO 1030
950       IF LABEL$(I)=LABEL$(IG%) GOTO 1000
960       SWAP LABEL$(I),LABEL$(IG%)
970       SWAP LINE.REF$(I),LINE.REF$(IG%)
980       SORTED=FALSE
990       GOTO 1030
1000      IF LINE.REF$(I)=LINE.REF$(IG%) GOTO 1030
1010      SWAP LINE.REF$(I),LINE.REF$(IG%)
1020      SORTED=FALSE
1030    NEXT I
1040  WEND
1050 WEND
1060 LOCATE 16,1 : PRINT "SORT COMPLETE . . . WRITING FILE" : PRINT
1070 REM
2000 REM***** CREATE FILE NAME FOR LISTING *****
2010 PERPOS = INSTR(FILENAME$,".") 'find position of period in filename
2020 IF PERPOS=0 THEN PERPOS=LEN(FILENAME$)+1 'if no period, pretend there is
2030 LISTFILE$ = LEFT$(FILENAME,PERPOS-1)+".CRF" 'create filename for listing
2040 OPEN LISTFILE$ FOR OUTPUT AS #2 'open sequential file for listing
2050 PRINT #2,"CROSS REFERENCE LISTING FOR PROGRAM FILE: ";FILENAME$
2060 PRINT #2,"CREATED AT "; TIME$; " ON "; DATE$
2070 REM
3000 REM***** WRITE CROSS REFERENCE TABLE TO FILE *****
3010 I = 1 : PRINT #2,
3020 WHILE I <= LABEL.NUMBER
3030   PRINT #2, "PRINT #2, LABEL$(I); TAB(10);
                                     ' N>3 gives 40 col
3040   CURRENT LABEL = LABEL$(I) : N=1 ' N>8 gives 80 col
3050   WHILE LABEL$(I) = CURRENT LABEL
3060     PRINT #2, USING "##### "; LINE.REF$(I);
3070     I=I+1 : N=N+1 : IF N>8 THEN PRINT #2, "PRINT #2, TAB(10); : N=1
3080   WEND
3090   PRINT #2, 'begin new line
3100 WEND
3110 PRINT #2, "KEY ON : BEEP : END
3120 REM
4000 REM***** SUBROUTINE TO OBTAIN BASIC'S OFFSET ADDRESS FOR THIS LINE*****
4010 GOSUB 7000 : LOW.BYTE = C
4020 GOSUB 7000 : HIGH.BYTE = C
4030 ADR = HIGH.BYTE * 256 + LOW.BYTE 'not really correct, but address is only of
4040 RETURN 'interest when zero, so this will do
4050 REM
5000 REM***** SUBROUTINE TO GET VARIABLE NAME *****
5010 LABEL.NUMBER = LABEL.NUMBER + 1

```

Listing 1 continued on page 382

'C' COMPILER

AN OUTSTANDING VALUE

"We bought and evaluated over \$1500.00 worth of 'C' compilers... C/80 is the one we use."

Dr. Bruce E. Wampler, Aspen Software
author of "Grammatik"

C/80 Full featured C Compiler for CP/M® with
I/O redirection, command expansion,
execution trace and profile, initializers,
Macro-80 compatibility, ROMable code. **49.95**

C/80 FLOATS & LONGS Adds 32 bit data
types to C/80 3.0 compiler. Includes
I/O and transcendental function library. **29.95**

FREE CATALOG Call or write for 16 page booklet
detailing our programming languages LISP/80,
RATFOR, Assemblers, and 25 other CP/M products.



15233 Ventura Blvd., #1118 (213) 986-4885
Sherman Oaks, CA 91403 Dealer inquiries invited.

CP/M is a registered trademark of Digital Research, Inc.

MAIL-COM™ Software Eliminates the 6 Costliest Steps of Business Mail Preparation

1. No More Addressing
2. No More Folding
3. No More Inserting
4. No More Affixing
5. No More Sealing
6. No More Drop Offs

Presenting E-Com.

Last year the U.S. Postal Service quietly announced E-Com, enabling specially equipped personal computer users to bypass costly manual mail preparation, by

electronically submitting their messages and mailing lists directly to the Postal Service via modem.

This high speed computer originated mail arrives at its destination within 48 hours—often less—in an attention-grabbing blue E-Com envelope.

Announcing MAIL-COM. Only from Digisoft Computers.

MAIL-COM is powerful software you can use with your personal computer to access E-Com. With your personal computer, a modem and MAIL-COM you can send from 200 to 2000 letters per hour for just 26¢ each. Typed, addressed, folded, inserted, sealed and delivered. Complete.

MAIL-COM even eliminates the need to use your expensive letterheads and envelopes.

MAIL-COM is the only interactive software available for E-Com operation. It's easy to use. No special training is necessary. And since Digisoft Computers developed MAIL-COM in accordance with U.S. Postal Service specifications, users are guaranteed certification for

use upon purchase of MAIL-COM software.

MAIL-COM is the easiest and most economical way to do your mailings. And MAIL-COM is compatible with Database II™ and Wordstar™ if you are equipped with these programs. If you aren't, MAIL-COM includes a complete letter editor and address maintenance program of its own.

Each letter in your mailing can be identical or all can contain variable insertions. MAIL-COM operates all the features offered by E-Com.

Thousands of Uses.

If you have need for fast, economical mass mailing capabilities, MAIL-COM puts you and E-Com together.



Use it for new product announcements, invitations to press events, invoicing, fund raising, collection, bulletins to your sales force, new business prospecting, reactivation of customers and much, much more. Every department in your company will have use for MAIL-COM.

Don't Delay

With MAIL-COM you could be saving time and money on fast, efficient E-Com letters. MAIL-COM software is available for the IBM PC, Victor, Alpha Micro,

CP/M, Apple CP/M and other formats. Order today. Call 212-734-3875, or mail the coupon below.



Digisoft

Digisoft Computers, Inc.

**Retail Dealer
Inquiries Invited**

Digisoft Computers Inc.
Attn: MAIL-COM Marketing
1501 Third Avenue
New York, NY 10028

Yes! I want to eliminate the 6 costliest steps in preparing my organization's business mail. Please RUSH my MAIL-COM software to me immediately.

I'll need software for:
 IBM PC (\$195) CP/M (\$195)
 Victor (\$195) (specify disk format)
 Alpha Micro (\$495) Other (specify)
 Apple CP/M (\$235)

My check or money order is enclosed (residents of New York State add sales tax).
 Charge my Visa or MasterCard:

Account No. _____ Exp. Date. _____

Name _____

Address _____

City _____

State _____ Zip _____

Telephone (_____) _____

© 1983, Digisoft Computers, Inc.

MicroAge[®]

"THE RIGHT COMPUTER STORE FRANCHISE FOR ME!"

"They wanted us to succeed and they acted like it!"

"At our West Palm Beach, Florida, MicroAge Computer Store, we sell primarily to business people, professionals and corporate accounts. Being part of the MicroAge Computer Store network gave us the knowledge, support and name recognition we found to be essential to our success. Plus, during our first year and a half, MicroAge developed a relationship with us that helped us bypass potential mistakes and grow."

"Since joining MicroAge, our store size has doubled and our staff has quadrupled. Today our store has expanded from 1,800 square feet to 3,700 square feet, while our staff grew from 3 people to 13 people. Our growth with MicroAge has been beyond my expectations."

"Am I satisfied with my MicroAge franchise... absolutely!"

Lonny Warshaw

Lonny Warshaw
President

To build your own professional computer sales organization with MicroAge write to:

MicroAge[®] COMPUTER STORES

Corporate Center
1457 West Alameda • Tempe, Arizona 85282

(602) 968-3168



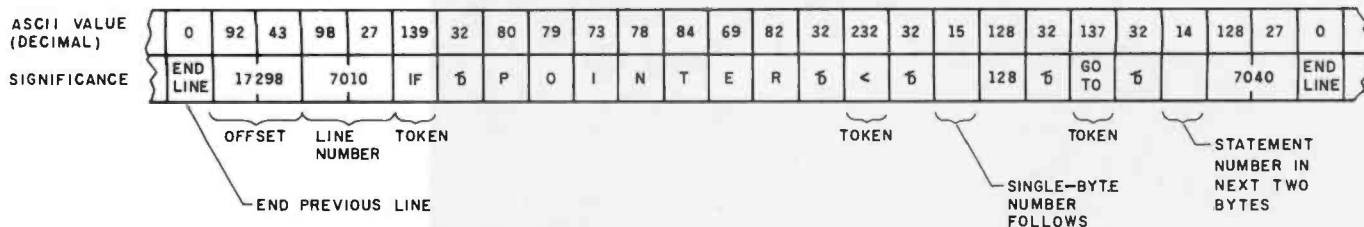

Figure 1: Tokenized format for line number 7010: 7010 IF POINTER < 128 GOTO 7040.

Text continued from page 378:

The program skips over all coded numbers except those prefixed by an ASCII 14. This code signifies a 2-byte number that is a program line-number reference, following a GOTO or GOSUB, for instance. The cross-reference listing program treats line-number references as labels and lists all lines referenced by other lines. This can help you find all the places in a program that call a certain subroutine.

How It Works

The format of the lines in a tokenized program file is shown in figure 1. The first 2 bytes are the BASIC offset address to the next program line. Our only interest in it is when it is 0 because a 0 offset signifies the end of the program. The next 2 bytes contain the line number, with the least significant byte first. These are followed by a series of bytes, including tokens, coded numbers, and variable names, up to the end of the line, indicated by an ASCII value of 0.

The approach of the cross-reference utility, then, is very simple. It makes a note of the line number being scanned at the moment, then skips over tokens and encoded numbers, looking for variable names and references to other program lines. When it finds the beginning of a variable name, it builds the name, character by character, until it comes to an ASCII code that can't be part of a variable name. If the variable has been explicitly typed (marked by a \$, #, !, %), that character is added to the end of the name. If the variable is subscripted, then "(SUB)" is added. Once complete, the variable name is stored in an array; the line number where it appears is stored in a parallel array of line numbers.

Once the entire program file has been scanned, the label and line-number arrays are sorted using a Shell sort. Then they are written to a disk file.

The only real problem is that all the scanning and sorting takes time. The program took nearly 7 minutes to process and sort labels for its own 145 lines and 245 label references. For a smaller program (123 references and 133 labels), it required 3 minutes 45 seconds. You can get a modest increase in speed of about 5 to 10 percent by eliminating comments and consolidating statements into one line where possible. This will have the greatest effect in the WHILE loop beginning at line 600 and the sort routine beginning at line 800.

Be Wary

In order not to slow the program down further, I kept it as simple as possible. Because of this, a few bogus variables may creep into your listing. These are words used as part of BASIC statements that are not tokenized. They include the following: ALL in a CHAIN statement, BASE in an OPTION BASE statement, B or BF in a LINE statement, R in a LOAD statement, AS in a FIELD or NAME statement, and AS, APPEND, or OUTPUT in an OPEN statement. None of these is a reserved word, and they are therefore not tokenized. Thus, if you use them in a program, the cross-reference utility will treat them as variable names. Note that both AS and OUTPUT appear in listing 2.

The cross-reference listing is written to a sequential disk file, which may be read later. The file name for the listing is the file name of the program file with an extension of CRF. If the original program file were MYPROG.BAS, the listing would appear on file MYPROG.CRF. To display the listing on your monitor, you first need access to the DOS (disk operating system)—execute SYSTEM from BASIC. When in DOS, execute TYPE MYPROG.CRF. If you want a hard copy, press the Ctrl and PrtSc keys simultaneously prior to executing the TYPE command; the listing on the monitor will then be output to the printer.

Modifications

The output is formatted for an 80-column screen or printer as the program appears in listing 1. To format for a 40-column screen, change N>8 in line 3070 to N>3. To format for a 132-column printer width, change it to N>16. You may also want to redimension the arrays in statement 110. They are large enough for modest programs, but larger programs with more references will need more space. ■

James A. Folts is an assistant professor of journalism at Oregon State University, Corvallis, OR 97331.

Author's Note: The slowness of this utility is primarily due to the slowness of the BASIC interpreter. The author has an object-code (compiled C) version of this algorithm that runs about 10 times faster than the BASIC version. Both copies are available on disk for \$15. Contact James A. Folts, 755 SW 55th, Corvallis, OR 97333.

Can you tell the IBM from the Transtar 130?

A

Letter quality
standard of
the industry

5x magnification

One of these two print samples was generated by an IBM Selectric II: the letter quality standard of the industry.

The other was generated by the new Transtar 130 letter-quality printer.

B

Letter quality
standard of
the industry

5x magnification

And print quality is just the beginning! The new Transtar 130 daisy wheel printer is also plug-and-go compatible with the best-selling word processing packages! It features bidirectional printing, superscript, subscript, underlining and a true boldface. Retail price? Only \$895.

Quietly producing copy at 18 cps Shannon text speed, the Transtar 130 also features a unique autoloop button to make printing on letterheads a breeze! Three new daisy wheels have just been made available for the 130 from your dealer: letter gothic (shown), script, and a 15-pitch "gothic mini"—perfect for printing spreadsheets to fit on one page!

Offering an end-user warranty period of a full six months, the Transtar 130 is an extraordinarily reliable machine. Its minimal failure rate runs less than 1%, but if your 130 should ever need repair, a nationwide network of authorized Transtar service centers stands ready.

Have you decided yet whose type is whose? If you picked A... You picked Transtar. The new standard for letter quality printing.



Transtar

P.O. Box C-96975, Bellevue, WA 98009

IBM is a registered trademark of International Business Machines, Inc.

Curious Coordinates for Computer Graphics

An elliptical coordinate scheme makes it easy to represent figures

by Roger C. Millikan

Plotters and dot-matrix printers that can handle graphics usually use x,y coordinate systems, or Cartesian coordinates. Yet universal and useful as those systems are, they are not always the best choice for all plotting tasks. Some figures can be much more easily specified in other coordinate systems.

The roses in figure 1—one with three and the other with seven petals—are a good example. The equations that describe them are much more simply written in polar coordinates than in x,y coordinates.

Perhaps more important is that, when polar coordinates are used to represent the roses, the integer multiplying T in the equation corresponds to an obvious feature of the resulting curve: the number of petals.

The role that coordinate systems play in graphics is analogous to the role that languages play in programming. Although a computer has a machine instruction set, the instructions are inconvenient for general use; therefore, high-level languages are set up to ease the task of specifying solutions to problems. Similarly,

a plotter's x,y coordinate system is seldom convenient to use unless it's scaled to match a particular problem. You must therefore define a new and more appropriate coordinate system to match the problem at hand. And just as a compiler maps a high-level source language into a computer's instruction set, you can use a subroutine to map a coordinate system into a plotter's coordinates.

Conversion Becomes Easy

The idea of using a subroutine to convert to x,y coordinates is simple, yet it gives you a lot of freedom. Polar coordinates may have seemed difficult to work with when you were in school, but programs running on calculators or computers have eased the conversion between polar and x,y systems. Given this ease, why stop with polar coordinates? Perhaps you can generalize them in interesting ways. Or maybe you'll discover systems that will make it easy to produce interesting graphics. All you need is the appropriate conversion subroutine for any set of coordinates.

Not surprisingly, symmetries in any coordinate system are reflected in the kind of curves that are easy to draw or specify. An Etch-a-Sketch,

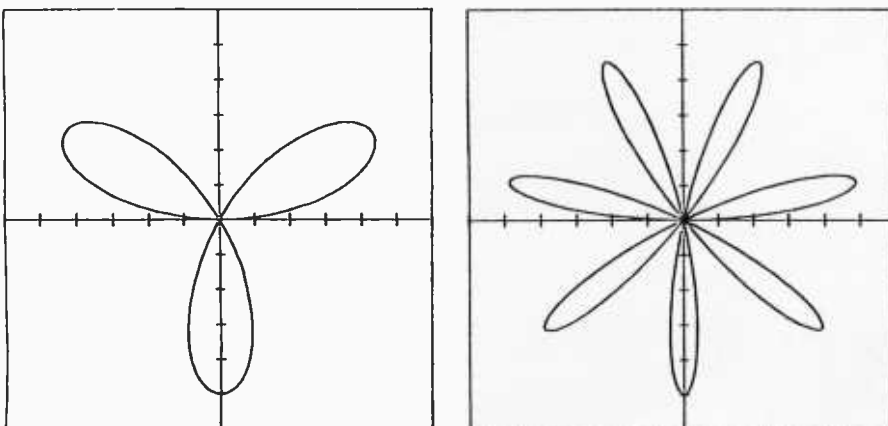

Figure 1: Three- and seven-leaf roses. In Cartesian coordinates, the equation for the three-leaf rose is $x^4 - 3x^2y + 2x^2y^2 - y^3 + y^4 = 0$. In polar coordinates, the equation becomes $r = \sin(3T)$. Can you guess the seven-leaf rose equation?

AMX

Real-Time Multitasking Executive

for
8080, Z80, 6809
and **8086**

Gives your application a head start

Save time and money in the development of your product or system by using AMX, the software executive with proven, fault-free operation.

SIMPLE OPERATION

You divide complex control programs into a number of separate, more manageable programs, called *tasks*, each designed to do one job. This allows tasks to be written and tested separately and then combined to form a reliable, finished system.

AMX supervises the orderly execution of these tasks, assuring that the most important jobs always get done first. Tasks appear to be executing simultaneously. It's almost like having a separate CPU for each task!

HARDWARE INDEPENDENCE

AMX does not require a particular hardware configuration. You control your environment. You pick the I/O method. You decide the preferred interrupt service technique for your system. AMX will support you on the microprocessor of your choice.

AMX is fast, compact, and ROMable. The AMX nucleus, less than 1400 bytes in size, features multiple task priorities, intertask message passing with priority queuing, external event synchronization, and interval timing.

Support modules provide extended memory management, buffer control and resource allocation. Fast, re-entrant integer and floating point math libraries are also available.

AMX interfaces support programs written in C, PASCAL, PL/M, FORTRAN and assembler.

Access to CP/M® disk files in real time is possible using the AMX I/O Supervisor.

COMPLETE DOCUMENTATION

We deliver AMX source on diskette to permit AMX to be moved to the software development system of your choice. Our liberal license agreement permits binary (object) distribution without royalties.

HOW TO ORDER

A specification sheet and price list are available, free. Your check or money order for \$75 will purchase the AMX Reference Manual for immediate evaluation (specify 8080, Z80, 8086 or 6809 processor). Add \$25 for postage and handling outside USA and Canada. The standard 8080/Z80 AMX Multitasking Executive package, including source code, is **\$800**. Support modules and interfaces are available separately.

AMX is the choice of professionals the world over. Make it yours, today.

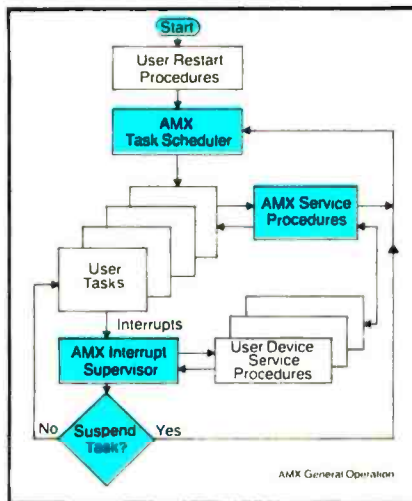

AMX is a trademark of KADAK Products Ltd.
CP/M is a trademark of Digital Research Corp.
Z80 is a trademark of Zilog Corp.



KADAK Products Ltd.



206-1847 W. Broadway Ave., Vancouver, B.C., Canada V6J 1Y5/Phone: (604) 734-2796 Telex: 04-55670

Circle 226 on inquiry card.

BYTE August 1983 387

for example, is great for drawing rectangular buildings, but did you ever try to draw a circle on one? Using polar coordinates, on the other hand, makes it especially easy to represent circular figures. You can, in fact, tailor the type of coordinates to suit any given purpose. If you want to draw elliptical figures, why not use an elliptical coordinate system?

Coordinate Systems with Parameters

Polar coordinates are based on the circle, the limiting form of an ellipse, where the distance between the two foci becomes zero. This fact suggests a natural generalization of polar coordinates: a system, which could be called elliptical polar coordinates of scale C , based on confocal ellipses in which each focus is a distance C from the origin. The variable C , a parameter of the coordinate system, is specified by the user. If possible, the system should be set up so that it becomes the standard polar-coordinate system when $C=0$. Then the conversion subroutine can provide conversions for a range of coordinate systems, including familiar ones.

Such a system is shown in figure 2b. The coordinates of a given point are R and T . In polar coordinates (figure 2a), R represents the radial distance from the pole to the point. The corresponding quantity in the elliptical system (figure 2b) is half the sum of the distances from the point to the two foci. The elliptical system's angle T is analogous to the polar

angle T . This is best seen in the plotting of constant coordinate lines as shown in figure 2. In figure 2b, where $C=400$ (i.e., each focus is 400 units from the origin along the x -axis), the ellipses are obtained for different constant values of R , while T goes from 0 to 2π radians. The lines that appear as hyperbolas result from setting the angle T to different constant values and, for each value of T , incrementing R from its lowest possible value ($R=C$) to higher ones. The conversion subroutine maps the grid of lines produced onto the normal rectangular grid of x,y lines that plotters use.

An Etch-a-Sketch is great for drawing rectangular buildings, but did you ever try to draw a circle on one?

This coordinate system depends on the parameter C . But what happens if you let that parameter become zero or, on the other hand, very large? The $C=0$ case is shown in figure 2a, where, as expected, the resulting coordinate grid is that of standard polar coordinates. Polar coordinates, then, are a special case of our more general coordinates. Perhaps more surprising is the case where C becomes large. Figure 2c depicts the grid that results when $C=10,000$. In a small region near the origin, the grid appears rectangular. It is linear in the x direction as T increases but

nonlinear in the y direction as R increases. Thus the elliptical system can smoothly transform rectangular-type coordinates to polar types.

By choosing a particular value for the parameter C , a particular instance of elliptical coordinates is selected. Yet C can also be treated as a variable in a computer-graphics program, and you can use this modulation of the coordinate system to produce special effects. For example, consider the rose with five petals that has the polar equation $R=1000\cos(5T)$. In the elliptical polar system of scale 400, the rose becomes a stylized stick man. And by redrawing him for $C=300, 200$, and 100 (figure 3), we take him through his exercises.

The BASIC program in listing 1 provides the conversion subroutine from these elliptical polar coordinates of scale C to Cartesian coordinates. A simple conversion, it needs little explanation. In it, the variable R cannot be less than C . In the polar case, this requirement corresponds to that of the radial distance from any point to the origin being positive. Mathematically, this restriction prevents the square root in the conversion from becoming imaginary. Should you call the subroutine with $R < C$, the minimum possible value, $R=C$, is used to generate the x,y coordinates. Handling an error condition this way permits the plot to proceed without being hampered by error messages. And to avoid corrupting further computations, the original value of R is maintained upon exiting the subroutine.

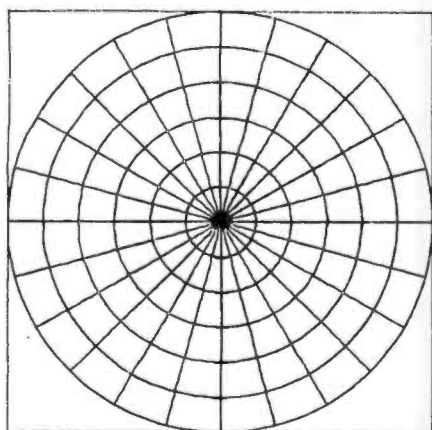

(2a)

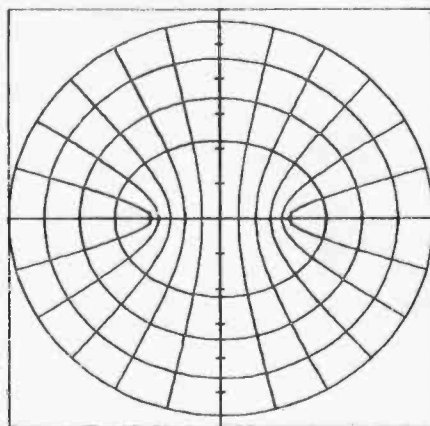

(2b)

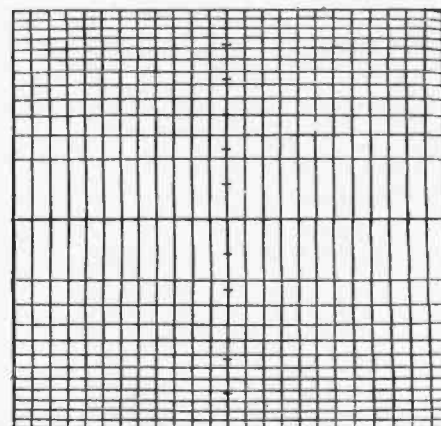

(2c)

Figure 2: Elliptical polar coordinate grids for different values of the scale parameter C . In (2a), $C=0$, in (2b), $C=400$, and in (2c), $C=10,000$.

How many companies offer
toll free **TOTAL SUPPORT** on
all hardware & software?

There is only one number to call:

1-800-237-8977

In Florida call 1-813-786-1259

Business Applications Software with
TOTAL SUPPORT...specializing in:
IBM[™], APPLE[™], TRS-80[™] and XEROX[™]

The Systems Group

2340 State Route 580/Suite 234
Clearwater, Florida 33575
Telex 701484

There is only one catalog to have:
our new, **free** 100 pages of the
best in hardware and software.
Send for your copy today!

IBM is a trademark of IBM Corporation
APPLE is a trademark of Apple Computer Inc.
TRS-80 is a trademark of The Radio Shack Division of Tandy Corporation
XEROX is a trademark of Xerox Corporation
Circle 375 on inquiry card.



EXPENSES

**CUSTOMER
LIST**

INVOICES

**PRODUCT
LIST**

TIME LOG

FIELD COMPANION™

Software For Portable And Desktop Computing

Now you can leave your office without abandoning your business. Gensoft has combined five of the most common business functions in one versatile software package: the **Field Companion**.

Don't overload your desktop or portable computer with five bulky programs when one will do it all. For instance, the **Field Companion** will help you:

- Summon product, parts or repair information when and where you need it.
- Update customer files and record memos.
- Stay on top of expenses — with a weekly expense tally itemized by day and category.
- Generate invoices or quotations, and store them for future reference.
- Record and compile the time you spend on each project or client.
- Interfaces with virtually any CP/M™-based word processor, allowing full editing of reports, journals, etc.

\$99.95

Introductory Price!!

The **Field Companion** provides universal business forms, concise on-screen instructions and password confidentiality. The regular price is \$129, but for a limited time you can order the **Field Companion** at our introductory price of **\$99.95**. Manual alone - \$10.



MONEY-BACK GUARANTEE: Examine the **Field Companion** for ten days after you receive it — if you have any doubt, send it back to us with the disk seal intact for a full refund.

Available for CP/M-80 and CP/M-86™ operating systems; MS-DOS version available third quarter 1983. Special Osborne 1 version is customized for smaller screens. Please specify computer make/model and disk format. Include street address for UPS delivery within 3-6 weeks. VISA, MasterCard, C.O.D. and personal or business checks accepted. Dealer inquiries welcomed.

CP/M and CP/M-86 are registered trademarks of Digital Research. Field Companion is a trademark of Gensoft Corporation.

Gensoft Corporation, an affiliate of Godbout Electronics,
2363A Boulevard Circle, Walnut Creek, CA 94595 — (415) 930-9330.

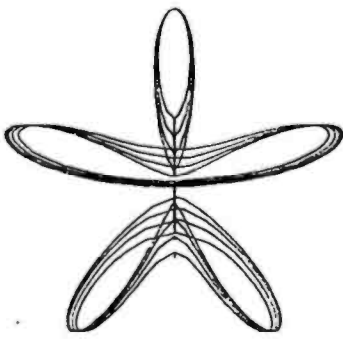

Jumping jacks

Figure 3: The result of changing the coordinate system parameter.

Listing 1: This BASIC program serves as the subroutine for converting elliptical polar coordinates of scale C to Cartesian types.

```

1000 REM SUBROUTINE CONVERTS ELLIPTICAL POLAR COORD
1002 REM OF SCALE 'C' TO CARTESIAN X,Y COORDINATES.
1004 REM 'C' IS DISTANCE FROM ORIGIN TO EACH FOCUS.
1006 REM FOR C=0, COORD. BECOME STD POLAR COORD.
1008 REM POINT IS P(R,T) WHERE 'R' IS RADIAL DISTANCE
1010 REM 'T' IS POLAR ANGLE IN RADIANS. IF R<C, THE
1012 REM CONVERSION USES R=C (IN THE POLAR CASE THIS
1014 REM MEANS THE RADIUS MUST BE POSITIVE).
1016 REM
1018 Q = R
1020 IF R >= C GOTO 1024
1022 Q = C
1024 X = Q*COS(T)
1026 Y = SQR(Q*Q-C*C)*SIN(T)
1028 RETURN

```

Additional 2-D and 3-D Coordinates

The elliptical polar system discussed here is just one example of a coordinate system that serves a specific purpose. Many other two-dimensional curves could serve as a basis for coordinate systems. The intersecting sets of logarithmic spirals in the seed arrangement of sunflowers is one interesting possibility

that would differ completely from polar or rectangular systems. Once you've developed a conversion subroutine, you can try old plotting programs using the new coordinate system—often with surprising results.

Three-dimensional space offers even more freedom for coordinate explorations. Helical systems and toroidal systems are possible. Of course, you'd need a way to depict

the results on a two-dimensional plotter . . . But that's just another subroutine. ■

Roger C. Millikan (5475 Tolttec Dr., Santa Barbara, CA 93111) is a professor of chemistry at the University of California, Santa Barbara. His interest in computing dates back to a \$1 million machine—the GE225 running Dartmouth BASIC—one about as powerful as the Z80 microcomputers of today.

The Latest Rage!

We have in-stock the latest Computer equipment at the lowest prices!

SANYO MBC 1200 \$1870.00

WORDSTAR, CALCSTAR, MAILMERGE, SPELLSTAR, INFOSTAR, SBASIC, CP/M, GAMES, TELECOMMUNICATIONS, AND UPDATED OPERATING SYSTEMS

ALL THE ABOVE PLUS

BIT MAPPED GRAPHICS AND 640 K DISK DRIVE

SANYO MBC 1250 \$2495.00
DUAL 640 K DISK DRIVES

(301)565-0559 DISCOUNT CENTER FOR:



COMPUTER DISCOUNT

P.O. Box 7716 Silver Spring, Maryland 20910

- SYSTEMS
- PRINTERS
- DRIVES
- DISKS
- PERIPHERALS
- ACCESSORIES

i3S COMPUTERTECHNIK 68000-CPU for APPLEBUS

Now waiting has an end. For all computers with APPLEBUS a 68000 system is available.

Using UNIX is possible. Through a universal memory expansion and multi interface you get a multi user systems for a low price.

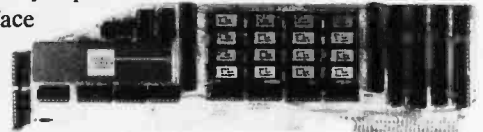

- 68000 CPU with 7 Mhz clock frequency
- 128 KB RAM you can also use as a pseudodisk
- memory expansion to 1 MB obtainable
- Interrupthandling 6502-68000
- 14 bit timer from 20 μs to 163ms
- comfortable fullscreen Editor Assembler

Available software: Editor Assembler DOS 3.3
Forth for 68000 (with DOS 3.3)
Pascal-, Basic-, Fortran (with UCSD-operating system)
Compiler for 68000
CP/M-68K with C-Compiler

AP 20 Intemex with 68000 CPU and 128K RAM 650\$

AP 26 Memory expansion for AP 20 256K RAM extendable to 1Mb RAM 720\$

Prices for Software for inquiry

i3S COMPUTERTECHNIK Opper Str. 10 1011 Rose Marie Lane 16
4800 Bielefeld 14 Stockton, CA 95207
Tel. 0521/444032 Tel. (209) 473-7473
West-Germany USA

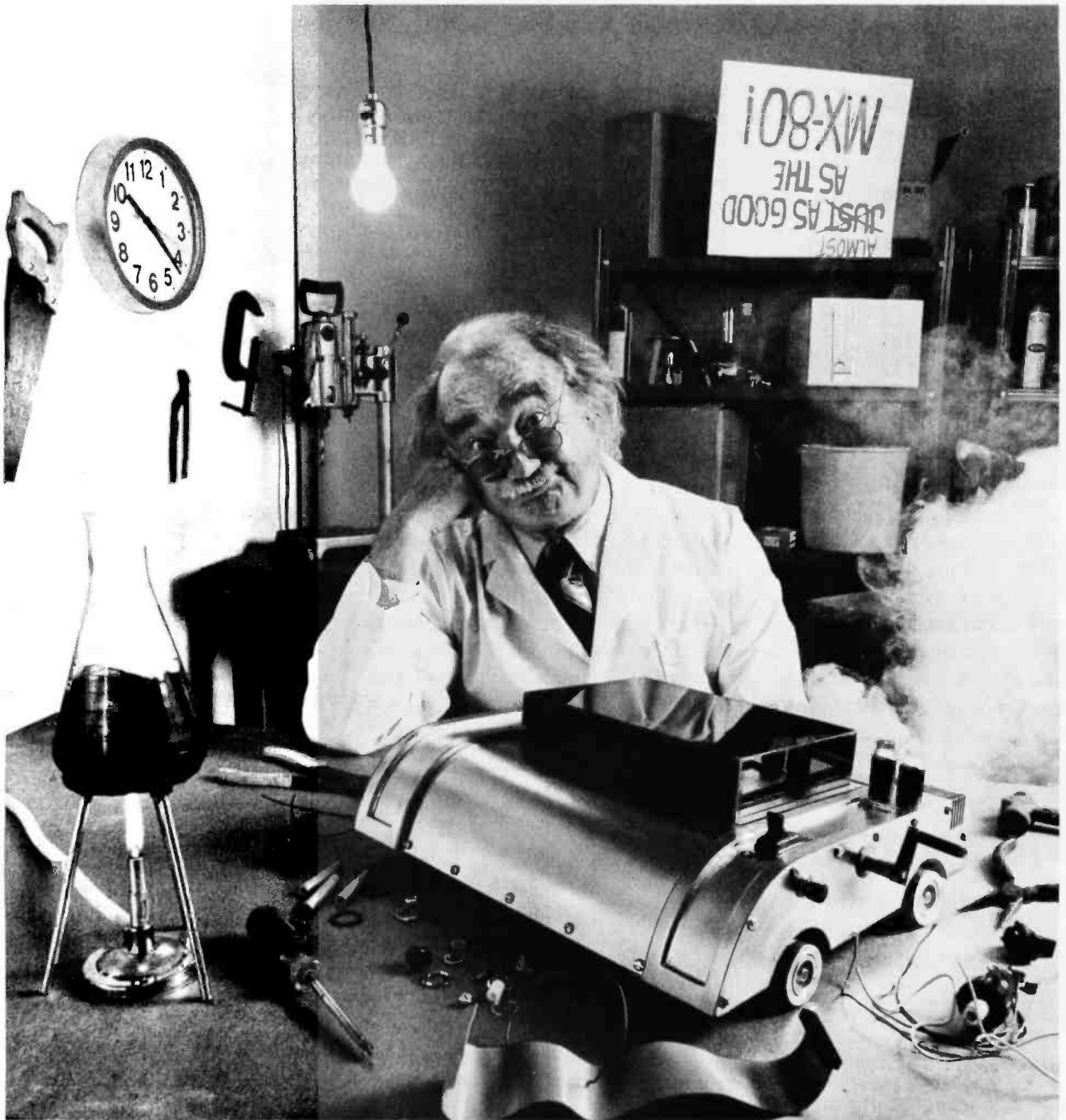

For everyone who's tried
to top the MX-80, bad news.
We just did.

Epson.

The Epson MX-80 is the best-selling dot matrix impact printer in the world. It has been since its introduction. And despite the host of imitators it spawned, no one has been able to top it. Until now.

FX-80: Son of a legend.

The new Epson FX-80 is far more than just doo-dads added on to last year's model. It's the most astonishing collection of features ever assembled in a personal printer.

For starters, it's fast: 160 CPS. And clean. All the print quality Epson is famous for in a tack-sharp 9x9 matrix.

But that hardly scratches the surface.

Create your own alphabet.

With the new FX-80, you aren't limited to ASCII characters. You can create your own. Any character or symbol that can be defined in a 9x11 matrix can be added to the FX-80's already impressive library of type styles and stored in its integral 2K RAM.

So you can create "Sally's Gothic" or "Tom's Roman" just by downloading and modifying standard characters. Or you can create a custom set from scratch. Either way, you can store up to 256 new characters. And if you don't need a new alphabet, the RAM functions as a 2K data input buffer.

Who knows graphics better than Epson?

Nobody, that's who. And if you don't believe it, witness the FX-80.

With a 12K ROM capacity, the FX-80 gives you a few things the others don't. For example, not one, not two, but *seven* different dot addressable graphic modes are program

selectable. And can be mixed in the same print line. Everything from 72 DPI (dots-per-inch) Plotter Graphics to the 640 dots per line resolution designed to match the remarkable monitor clarity of the Epson QX-10 personal computer.

And *that* is in addition to an astonishing array of 136 different user-selectable type styles including Proportional, Elite and Italic as well as the more conventional faces you get on other printers.

Hard-to-beat hardware.

The FX-80 has all the hardware features you've come to know and love on the MX Series: logic seeking, bidirectional printing, the by-now-famous disposable printhead, and more.

The FX-80 features an adjustable pin platen or optional friction/tractor feed, so you can use fanfold, roll or sheet paper . . . backwards or forwards. The FX-80 even gives you reverse paper feed.

And if you're printing forms, the FX-80 has a feature you're gonna love: a function that allows you to tear off the paper within one inch of the last print position.

Be the first on your block.

We'd be willing to bet that the FX-80 — like the MX-80 — will have its share of imitators. Don't be fooled. To make sure you get the genuine article, rush down to your local computer store right now and let them show you everything the FX-80 can do.

And while you're there . . . ask them to show you how it works with our computers.

The New
Epson FX-80.
See it at your
dealer now.



EPSON
EPSON AMERICA, INC.
COMPUTER PRODUCTS DIVISION

3415 Kashiwa Street
Torrance, California 90505
(213) 539-9140.
Outside California, phone
(800) 421-5426 for the
Epson dealer nearest you.

Circle 165 on Inquiry card.

A Gauss-Jordan Elimination Method Program

A flexible routine solves simultaneous linear equations

by Patrick E. McGuire

You can often represent a technical problem as a system of simultaneous linear equations, forming the familiar set of n equations and n unknowns. One common approach for solving these equations is the Gauss-Jordan elimination method, which is rigidly systematic and straightforward for computer applications. To demonstrate, I'll describe a versatile program, which does the following, using the Gauss-Jordan elimination method:

1. Given a matrix of coefficients from any arbitrary-size system of equations, the program solves for the unknowns.
2. When used in its entirety, the program functions in a calculator mode, i.e., coefficients are entered in response to program prompts. The unknowns are then solved. Also, the determinant of the matrix is generated as well as the inverse. The latter is a preliminary step for matrix division. The input is echoed to a line printer, and, of course, the results are printed.
3. When modified slightly, the program performs as a concise subroutine for use in a larger program. In this case, the input takes the form of an array supplied by the calling program. Output from the subroutine is then made available in an extended form of the same array.

The program given in listing 1 is written in Level II (Microsoft) BASIC as implemented on the TRS-80 Model I microcomputer. You should have few, if any, problems adapting the program to other machines.

I'll briefly review the steps involved in the Gauss-

Jordan elimination method to clarify how you can use listing 1.

The Method

Any system of simultaneous equations can be represented in general form as shown in figure 1a. A square array formed by the coefficients of x_i from figure 1a establishes the coefficient matrix. You append the values from the right-hand side of the equations to the array to form the augmented matrix, as shown in figure 1b.

You can represent the Gauss-Jordan elimination method operating on this augmented matrix in pseudo-code as shown in figure 2. When you read this procedure, note that the array is continually altered as the various loops progress. Any term labeled "a" in the process is the matrix element that remains after all previous operations have been completed. After these nested loops are performed, the solutions appear in the right-hand column of the augmented matrix as shown:

$$\begin{array}{l} x_1 = a'_{1,n+1} \\ x_2 = a'_{2,n+1} \\ x_3 = a'_{3,n+1} \\ \text{---} \\ \text{---} \\ \text{---} \\ x_n = a'_{n,n+1} \end{array}$$

The primes indicate the values derived from the numerous divisions, multiplications, and subtractions performed in the loops.

Text continued on page 398

Listing on page 396

Pro-Net™ System

Professional Local Area Network

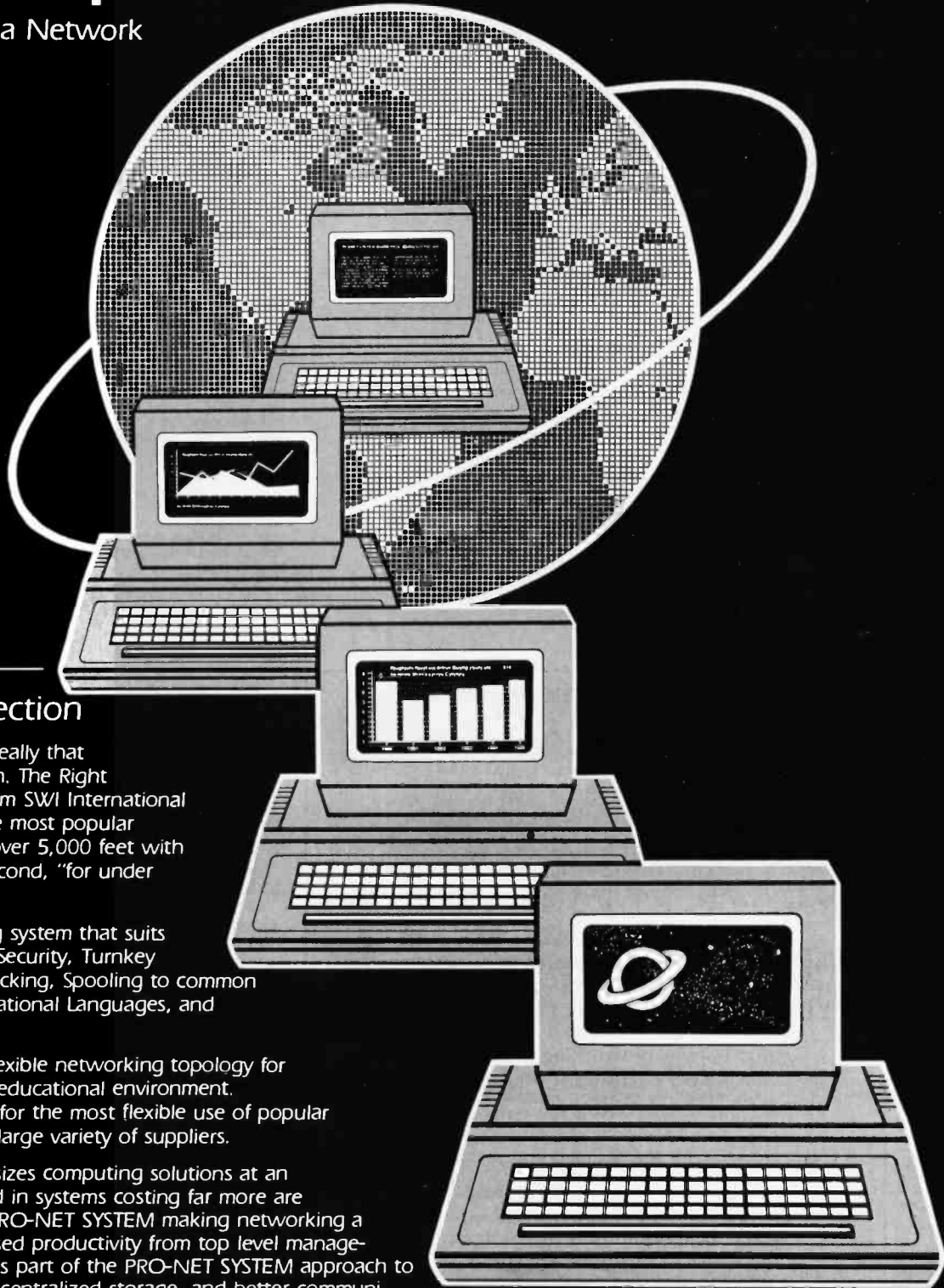

What's Your Connection

Being well connected is not Really that Difficult! Make the Connection. The Right Connection. The PRO-NET from SWI International Systems, links up to 128 of the most popular microcomputers at distances over 5,000 feet with speeds at 4 million bits per second, "for under \$300.00 per computer."

Select the multi-user operating system that suits you best, featuring Password Security, Turnkey Command, File and Record Locking, Spooling to common Printers, Electronic Mail, Educational Languages, and more...much more.

Take advantage of the most flexible networking topology for your business, professional or educational environment. PRO-NET SYSTEM also allows for the most flexible use of popular mass storage available from a large variety of suppliers.

The PRO-NET SYSTEM emphasizes computing solutions at an affordable cost. Features found in systems costing far more are standard components of the PRO-NET SYSTEM making networking a cost-effective necessity. Increased productivity from top level management to the department level is part of the PRO-NET SYSTEM approach to distributed computing power, centralized storage, and better communications. The PRO-NET SYSTEM provides the missing element to make your personal computer a versatile distributed networking communication solution.

SWI INTERNATIONAL SYSTEMS™

Specialist in Networking
For Microcomputers

See the PRO-NET SYSTEM at your local SWI INTERNATIONAL SYSTEMS dealer.

7741 East Gray Road, Suite 2 • Scottsdale, Arizona 85260-3496 • 602 998-3986 Telex: 467580

Circle 356 on inquiry card.

www.americanradiohistory.com

Listing 1: This version of the program stands alone and can be used in a calculator mode (as defined in the text) to solve linear systems.

```

100 / Program module for solution of arbitrary size
110 / systems of linear equations. Solution method is
120 / Gauss-Jordan Elimination. In addition to the
130 / solution vector the matrix inverse is also derived.
140 / -----
150 / Patrick McGuire
160 / Lafayette, LA --- 1980
170 / -----
180 /
190 / The first section is a small utility for use in testing
200 / the module using keyboard array entry. It may also be used
210 / "as is" to solve linear systems.
220 CLS
230 INPUT "ENTER MATRIX SIZE, (N X N), ENTER N:" N
240 DIM A(N,N),M(2*N+1)
250 FOR X=1 TO N
260 FOR Y=1 TO N+1
270 PRINT "ENTER ELEMENT ";X;Y
280 INPUT A(X,Y)
290 NEXT Y
300 NEXT X
310 / End utility section
320 / -----
330 / Extend matrix array for inverse generation
340 V=N+1
350 FOR X= 1 TO N
360 V=V+1
370 A(X,V)=1
380 NEXT X
390 / End extension section
400 / -----
410 / This section prints input and extended array
420 LPRINT TAB(15);"GAUSS-JORDAN ELIMINATION"
430 LPRINT TAB(15);"Input Data and Array Setup"
440 FLAG=1: / Suppress determinant printings
450 GOSUB 970
460 FLAG=0: / Reactivate determinant printings
470 LPRINT: LPRINT
480 / End input printings section
490 / -----
500 /
510 / Begin actual solution
520 / -----
530 / Pivot row normalization section: divides by the diagonal
540 DET=1: / Initialize the determinant

```

```

550 FOR R=1 TO N
560 J=2*N+1
570 DIU=A(R,R)
580 DET=DET*DIU: / Update determinant
590 FOR H=1 TO J
600 A(R,H)=A(R,H)/DIU
610 NEXT H
620 / End row normalization section
630 / -----
640 / Non-Pivot row reduction section
650 FOR S=1 TO N
660 Q=A(S,R)
670 IF S=R GOTO 710
680 FOR T=1 TO J
690 A(S,T)=A(S,T)-A(R,T)*Q
700 NEXT T
710 NEXT S
720 / End row reduction section
730 / -----
740 NEXT R
750 / -----
760 / End of solution sections
770 / -----
780 /
790 / Print heading for solution output
800 LPRINT TAB(15);"Gauss-Jordan Elimination Results"
810 GOSUB 970
820 FOR P=1 TO 6: LPRINT: NEXT P
830 END
840 / -----
850 / -----
860 / Line printer output subroutine
870 FOR X=1 TO N
880 FOR Y=1 TO 2*N+1
890 LPRINT USING "###.###";A(X,Y):
900 LPRINT " ";
910 NEXT Y
920 LPRINT
930 NEXT X
940 LPRINT
950 IF FLAG=1 GOTO 970
960 LPRINT "DETERMINANT = ";DET
970 RETURN

```

Expand Your Networking Capabilities

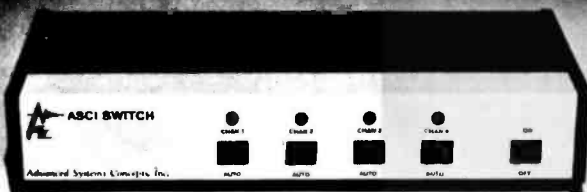

With ASCII - The Interface Experts

ASCII Switches can solve your RS-232 and Parallel networking problems

Other companies sell you boxes... ASCII has customized interfaces. For the same price as an off the shelf product, ASCII can provide the service you need to develop a network that works for you.

ASCII gives you the interfacing products that enable you to create...

- Office Automation Systems
- Peripheral Sharing Systems
- Scientific Equipment Mix/Matching
- Process Control Networks

Call ASCII today and receive our FREE brochure—Low Cost Local Area Networking...

213-793-8971



Advanced Systems Concepts, Inc.

435 N. LAKE AVENUE, DEPT. B
PASADENA, CALIFORNIA 91101
TELEX: 701 215

THIS IS THE YEAR OF THE HARD DISK. TRADE-IN YOUR EXISTING 5¼" DOUBLE SIDED, DOUBLE DENSITY DISK DRIVE ON A NEW 5¼" WINCHESTER SUBSYSTEM. McNEILL WILL GIVE YOU \$200 FOR YOUR OLD DRIVE, TOWARD THE PURCHASE OF ANY ONE OF THE FOLLOWING HARD DISK SUBSYSTEMS.

10 MB IMI formatted subsystem (2 yr. LTD warranty)	\$1849 \$1995
22 MB AMPEX formatted subsystem (1 yr. LTD warranty)	\$2499 \$2695
44 MB AMPEX formatted subsystem (1 yr. LTD warranty)	\$3499 \$3595

Hard disk subsystems include Z80 interface card, controller cabinet, power supply, cables, and hard disk. Compatible with: IBM-PC, Osborne, North Star, TRS-80 Model II, Televideo 802, Apple with CP/M, Heath/Zenith, any Z80 S-100 System.

We carry most major brands of memory boards for your IBM-PC AST Research, Persyst, Seattle, Quadram.

QUADLINK - Apple Software on IBM \$549

We carry most major brands of printers. Here are a few examples of our prices:

Epson FX80 (in stock)	\$549
Prowriter 8510Ag	\$379
C. Itoh F-10	\$1199

Special Department for Universities. We accept purchase orders. All prices are F.O.B. El Toro, CA. All prices are subject to change.

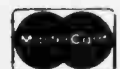
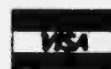

714-768-8114

Suite 186 • 25422 Trabucco Rd. #105, El Toro, CA 92630
In Europe: McNeill, 138 University St., Belfast, Northern Ireland
BT7 1JH TELEX 74351

Introducing a sensible solution to the problems of dBASE II.™

	dBASE II	The Sensible Solution
Records Per File	65,535	999,999
Maximum Record Size	1,024 bytes	1,536 bytes
Fields Per Record	32	384
Key Fields Per File	7	10
Number of Files Simultaneously Accessible	2	10
Number of Screens Per Program	Limited by system memory	Limited only by system storage
Data Dictionary	No	Yes

We don't mean to debase dBASE II, but if you're looking for a data base manager that's long on features, dBASE II can come up a little short.

For instance, a single dBASE II record can only contain 32 fields. And when you need to share information between one file and another, you can only access two at a time.

So, as good as dBASE II is, its limitations can quickly paint you into an electronic corner.

And that's why we created *The Sensible Solution*.

Finally. A sensational relational.

Along with all the usual things you expect from a data base manager, *The Sensible Solution* lets you handle the kind of tough assignments that dBASE II can't:

You can design data files with more than 300 variables. You can create reports using 10 different files at once. You can even set up file locking for multi-user computers.

Ready to get down to business.

A data base manager without ready-to-run application programs is hardly worth the disk it's copied on.

So, along with *The Sensible Solution*, you can also add *The Sensible Solution Bookkeeper*™ or *Sensible Management*™, our complete one-entry accounting and management system.

They're both affordable. Business-tested. And supplied with source code so you can make your own modifications.

A sensible trial offer.

When you purchase *The Sensible Solution*, we'll send along a special trial disk that lets you create forms and enter a limited number of records. If, after 30 days, you're not satisfied, just return the unopened master system disk for a full refund.

So why not take us up on our trial offer? You've got nothing to lose.

Except the problems of dBASE II.

The Sensible Solution™

To order, write or call: O'Hanlon Computer Systems, 11058 Main Street, Bellevue, WA 98004 USA, Phone (206) 454-2261. Prices: *The Sensible Solution*—\$695, *Sensible Solution Bookkeeper*—\$495, *Sensible Management*—\$895. In Washington, add 6.5% state tax. VISA, Mastercard and dealer inquiries welcome.

dBASE II is a registered trademark of Ashton-Tate. Sensible Solution, Sensible Solution Bookkeeper and Sensible Solution Management are trademarks of O'Hanlon Computer Systems, Inc.

(1a)

$$\begin{aligned}
 a_{11}x_1 + a_{12}x_2 + a_{13}x_3 + \dots + a_{1n}x_n &= a_{1,n+1} \\
 a_{21}x_1 + a_{22}x_2 + \dots + a_{2n}x_n &= a_{2,n+1} \\
 a_{31}x_1 + \dots + a_{3n}x_n &= a_{3,n+1} \\
 &\vdots \\
 &\vdots \\
 &\vdots \\
 a_{n1}x_1 + \dots + a_{nn}x_n &= a_{n,n+1}
 \end{aligned}$$

(1b)

$$\begin{array}{cccccccc}
 a_{11} & a_{12} & a_{13} & \dots & a_{1n} & & a_{1,n+1} & \\
 a_{21} & a_{22} & & \dots & a_{2n} & & a_{2,n+1} & \\
 a_{31} & & & \dots & a_{3n} & & a_{3,n+1} & \\
 & & & & & & & \vdots \\
 & & & & & & & \vdots \\
 & & & & & & & \vdots \\
 & & & & & & & \vdots \\
 a_{n1} & & & \dots & a_{nn} & & a_{n,n+1} &
 \end{array}$$

Figure 1: A general representation of any set of simultaneous equations is shown in figure 1a. The coefficient array from the system of equations in 1a sets up the solution for $x_1, x_2, x_3,$ etc., when you form the augmented matrix shown in 1b by appending the values from the right-hand side of the equation to the array.

```

for k = 1 to n
  for i = 1 to n
    for j = 1 to (n + 1)
      aij = aij/akk, when i = k
      or
      aij = aij - (akj/akk)(aik), when i ≠ k
    next j
  next i
next k
end
    
```

Figure 2: The Gauss-Jordan elimination method, shown here in pseudocode, can be used to solve most simultaneous systems of equations.

$$\begin{array}{cccccccc}
 a_{11} & a_{12} & a_{13} & \dots & a_{1,n+1} & 1 & 0 & 0 & \dots & 0 \\
 a_{21} & a_{22} & & \dots & a_{2,n+1} & 0 & 1 & 0 & \dots & 0 \\
 a_{31} & a_{32} & & \dots & a_{3,n+1} & 0 & 0 & 1 & \dots & 0 \\
 & & & & & & & & & \vdots \\
 & & & & & & & & & \vdots \\
 & & & & & & & & & \vdots \\
 & & & & & & & & & \vdots \\
 a_{n1} & & & \dots & a_{n,n+1} & 0 & 0 & & \dots & 1
 \end{array}$$

Figure 3: Appending the array of 1s and 0s prior to performing the elimination procedure automatically yields the matrix inverse.

The inverse of the coefficient matrix can also be generated simultaneously during this routine. To do this, the original array (see figure 1b) is extended to include an identity matrix of size n , as shown in figure 3. Then, the inner loop of the pseudocode is extended to

$$\text{for } j = 1 \text{ to } (2n + 1)$$

After the program is run, the matrix inverse is the result of the operations performed on the identity matrix.

The coefficient-matrix determinant can also be concurrently derived by taking the product of each term a_{kk} , as it is encountered, while the loops proceed. Called *pivot elements*, these terms lie along the diagonal of the matrix.

For additional information on linear systems analysis and matrix manipulation in general, see *Computational Matrix Algebra* by David Steinberg (McGraw-Hill, 1974).

Using the Program

Use of the program in listing 1 is straightforward. As a problem-solving tool or teaching aid, the entire listing as given should be employed.

Operating as a stand-alone program, the routine first asks for the matrix size n of the $n \times n$ coefficient array. Then, the user is prompted to enter the augmented array, element by element. The first entry is element 1,1 and the last is $n, n + 1$.

After the last data entry, the program adds the array extension for generating the inverse, prints the input data (with extension), and proceeds with the solution. The solution sequence performed next is similar to the preceding pseudocode. Finally, the program prints the solution array along with the determinant.

Figure 4 shows a sample run based on the following set of equations:

$$\begin{aligned}
 2x_1 - 4x_2 + 5x_3 &= 6 \\
 7x_1 + 4x_2 + 5x_3 &= 6 \\
 2x_1 - 3x_2 + 6x_3 &= 5
 \end{aligned}$$

Note that the solutions

$$x_1 = 1.443, x_2 = -0.902, \text{ and } x_3 = -0.098$$

appear in the $n + 1$ column of the resulting array. In this case, the solution vector lies in the fourth column, and the determinant of the coefficient matrix given in the original first three (n) columns is 61.

You should use the version in listing 2 when you want the program to be a subroutine in a larger program. The calling program must have previously filled the array A with data and specified the value of N, where N equals n of an $n \times n$ system. After the equation is solved, the main program can extract the solution vector and/or the inverse from the extended array. The determinant is also available as the variable DET. The calling program must include a dimension statement allotting enough space for the largest array (n by $2n + 1$) to be solved.

the "Better" Board™

SB-80 Single Board Computer

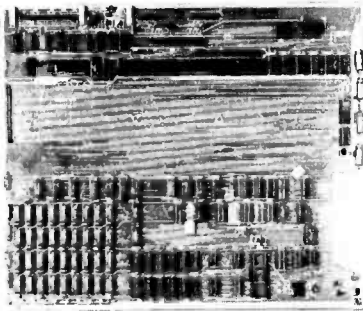

**Z-80-A
64K RAM**
Fully Assembled and Tested

Size: 16" x 13"
Same as 2 8" floppy drives. Requires:
+5V 1.5 Amp
+5V 1.0 Amp
+12V 1.5 Amp

\$425.00*

The SB-80 single computer board along with 1 or 2 8 inch disk drives, a power supply, an enclosure, and a CRT give you a complete computer system that can be used for either business or personal use and will still allow for upgrade options (up to 4 floppy drives, 5 to 40 meg hard disk).

CONSTRUCTION

- Computer is fabricated on a single printed circuit board.
- Sockets for all integrated circuits.
- 50 pin connector allows access to system for future expansion.

PROCESSOR

- Z80A with 4 MHZ system clock with no wait states.

MEMORY

- 64K of 200ns dynamic RAM is standard .4116 IC's.
- Parity protection is standard. A memory error places the system in a permanent wait state and lights on LED indicator.

ROM

- 256 bytes bootstrap

2 SERIAL I/Os

- Z80A-SIO/O dual channel chip.
- Two complete bidirectional serial ports with RS232 buffering. Fully programmable for Asynch. Bisynch, and SDLC.
- Programmable dual baud rate generator on board. Selectable baud rates up to 19.2kb. Provisions for modem supplied clocks.
- Interrupts or polling under program control.

2 PARALLEL I/Os

- Z80A-PIO chip.
- Two complete TTL eight-bit bidirectional ports with extra handshake lines. Interrupts or pollings under program control.
- Printer support through one parallel port.

COUNTER/TIMERS

- Z80A-CTC chip
- Four separate counter/timers under program control. Counters can count external events and can interrupt or be polled. Timers are programmed to interrupt or signal an external device after a desired time interval.

FLOPPY DISK CONTROLLER

- Uses Western Digital 1793 controller chip which supports soft-sectored formats under program control.
- Standard IBM — CP/M single density formats or double density 600K bytes per side. Density is selected by way of software control; runs CP/M 2.2*.

EXPANSION

- 50 pin connector bus allows for future expansion capabilities.

OPTIONAL

- Winchester Host Adaptor board for Shugart SA-1000 or Corvus Hard Disk. Includes Cables. \$236.00

- SB-80 BIOS is available for \$45.00 CP/M* 2.2 modified by S & M Systems to run on a single board is available for \$130.00
- SB-80 Technical Manual \$60.00

Colonial Data

SB-88

16 BIT
IBM PC® COMPATIBLE

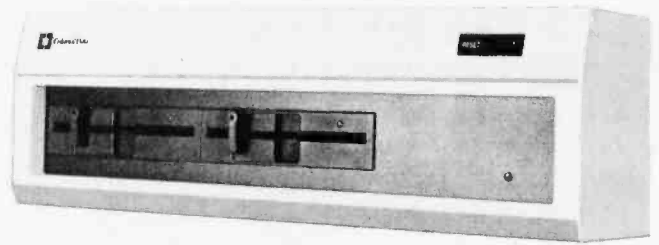

\$1995.00

- 16-BIT — 8088 Processor
- 64K RAM (Expand to 256K)
- Dual 409 KBYTES 5 1/4" Floppies
- Runs MS-DOS® Operating System
- Includes RS232C Port
- Total of 5 Expansion Slots

Additional 64K RAM \$90.00

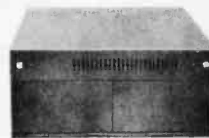

CABINET KITS

Metal cabinet with proportionately balanced air flow-convection cooling, AC power cord connector, lighted power switch, Fuse assembly, OL65 Dual drive power supply (Will also power single board CPU). All hardware included to mount 2 8" disk drives. Includes space area to mount any single board computer. Fully assembled and tested.

SB- Cabinet Kit \$395.00
SB- Bare Cabinet \$145.00



SHUGART FLOPPY DISK DRIVES

455 (5 1/4" DS/DD) Slim \$230.00 2/440.00
801 (8" SS/DD) \$385.00 2/750.00
851 (8" DS/DD) \$485.00 2/940.00
860 (8" DS/DD) Slim \$475.00 2/920.00



PRINTERS

Okidata Microline 80 (80 col, 80 cps) \$350.00
Okidata Microline 82A (80 col, 120 cps) \$450.00
Okidata Microline 92 (80 col, 160 cps) \$550.00
Okidata Microline 93 (136 col, 160 cps) \$950.00
C. Itoh Starwriter 40 (40 cps, Daisy) \$1400.00
C. Itoh Starwriter 55 (55 cps, Daisy) \$1700.00

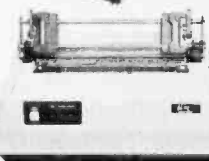

TERMINALS, KEYBOARDS, CRTs

ADDS Viewpoint Terminal \$570.00
Keytronics IBM Compatible Keyboard \$250.00
"Gorilla" Monochrome Monitor (12") \$99.00
Princeton Graphic Systems RGB
Color Monitor (IBM Compatible) \$499.00



HOW TO ORDER Phone orders using American Express, Visa, MasterCard, Bank wire transfer, Cashier's or Certified check, Money Order, or Personal Check (allow 10 days to clear). Please add 5% for shipping, handling and insurance. Connecticut residents add 7.5% sales tax. All equipment is subject to price changes and availability without notice. All equipment is new and comes complete with manufacturers warranty. Showroom prices may differ from mail-order advertisement.



Colonial Data Services Corp.

105 Sanford Street Hamden, Conn. 06514
(203) 288-2524 • Telex: 956014

* 1 to 4 piece domestic U.S. price

® IBM PC is a registered trademark of IBM Corporation.

® MS-DOS is a registered trademark of MICROSOFT.

® CP/M is a trademark of Digital Research Corp.

```

(4a) ENTER MATRIX SIZE, (N x N), ENTER N? 3
      ENTER ELEMENT 1 1
      ? 2
      ENTER ELEMENT 1 2
      ? -4
      ENTER ELEMENT 1 3
      ? 5
      ENTER ELEMENT 1 4
      ? 6
      ENTER ELEMENT 2 1
      ? 7
      ENTER ELEMENT 2 2
      ? 4
      ENTER ELEMENT 2 3
      ? 5
      ENTER ELEMENT 2 4
      ? 6
      ENTER ELEMENT 3 1
      ? 2
      ENTER ELEMENT 3 2
      ? -3
      ENTER ELEMENT 3 3
      ? 6
      ENTER ELEMENT 3 4
      ? 5
  
```

```

(4b)          Gauss-Jordan Elimination
          Input Data and Array Setup
2.000 -4.000 5.000 6.000 1.000 0.000 0.000
7.000 4.000 5.000 6.000 0.000 1.000 0.000
2.000 -3.000 6.000 5.000 0.000 0.000 1.000
  
```

```

(4c)          Gauss-Jordan Elimination Results
1.000 0.000 0.000 1.443 0.639 0.148 -0.656
0.000 1.000 0.000 -0.902 -0.525 0.033 0.410
0.000 0.000 1.000 -0.098 -0.475 -0.033 0.590
  
```

Determinant = 61

Figure 4: The example system of equations given in the text is solved here using the program in listing 1. Figure 4a is an illustration of the data-entry process as it appears on screen. Figure 4b is the augmented matrix with appended 1s and 0s formed from the input data. Figure 4c shows the solved matrix; values of the unknowns x_1 , x_2 , and x_3 are in the fourth column in this case.

Summary

The version of the Gauss-Jordan elimination method described here includes some compromises. For example, if any of the diagonal elements (a_{11} , a_{22} , a_{33} , etc.) are

Listing 2: This is an abbreviated form of listing 1, which is intended for use as a subroutine in a larger program.

```

50000 / Subroutine to perform Gauss-Jordan solution
50010 / of simultaneous linear equations. The matrix
50020 / inverse and determinant are also derived.
-----
50040 / Patrick McGuire
50050 / Lafayette, LA --- 1980
-----
50070 /
50080 / Extend matrix array for inverse generation
50090 V=N+1
50100 FOR X=1 TO N
50110 V=V+1
50120 I=N+2: J=2*N+1
50130 FOR K=1 TO J
50140 A(X,K)=0
50150 IF K=V THEN A(X,K)=1
50160 NEXT K
50170 NEXT X
50180 / End extension section
-----
50190 /
50200 / Begin actual solution
-----
50210 /
50220 /
50230 / Pivot row normalization section: divides by the diagonal
50240 DET=1: Initialize the determinant
50250 FOR K=1 TO N
50260 J=2*N+1
50270 DIU=A(R,R)
50280 DET=DET*DIU: Update determinant
50290 FOR H=1 TO J
50300 A(R,H)=A(R,H)/DIU
50310 NEXT H
50320 / End row normalization section
-----
50330 /
50340 / Non-Pivot row reduction section
50350 FOR S=1 TO N
50360 Q=A(S,R)
50370 IF S=R GOTO 50410
50380 FOR T=1 TO J
50390 A(S,T)=A(S,T)-A(R,T)*Q
50400 NEXT T
50410 NEXT S
50420 / End row reduction section
-----
50430 /
50440 NEXT R
50450 /
50460 / End of solution sections
50470 /
50480 /
50490 RETURN
  
```

or become equal to 0, the solution fails. Ways exist to overcome this deficiency, but the inverse generation and determinant features are destroyed if you use simpler methods. There is another method, called the Maximum Pivot method, which overcomes the zero-diagonal problem and retains the other features. However, this procedure is significantly more complicated and time-consuming. Fortunately, most physical problems do not exhibit the zero-diagonal difficulty. ■

Patrick E. McGuire (102 Duncan Circle, Lafayette, LA 70503) is a registered professional petroleum engineer and assistant district manager of a major oil company.

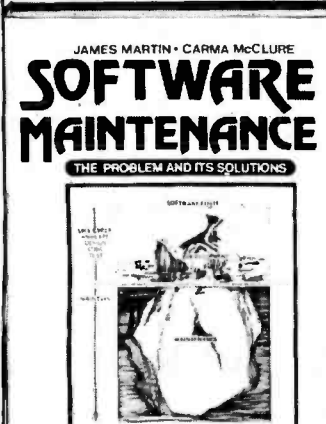

McGraw-Hill Bookstore

Please print clearly.

McGraw-Hill Bookstore
1221 Avenue of the Americas
N.Y., N.Y. 10020 B834

Please send me _____ copies of
Software Maintenance by James Martin
and Carma McClure at \$38.00 each.

MasterCard _____ Visa _____ AmerExp _____

Account No. _____ Expires _____

Name _____

Address _____

City _____ State _____ Zip _____

Add sales tax plus \$2.50 postage, handling



How to increase control and cut programming costs in DP installations

SOFTWARE MAINTENANCE

The Problem and Its Solutions

by James Martin and Carma McClure

For the many organizations that maintain old systems at great cost, this book introduces techniques to increase control and cut costs. 472 pp. \$38.00

The Future of Software Design

Industry looks to software as the source of the next wave of innovation in microcomputers

by William Gates

Software, after years of taking a backseat to hardware, has finally come into its own. Today there is general acknowledgment of software's importance. It is the bridge between the machine and the user—the tool that brings the power of the computer to the user. And software is defining today's crucial information issues.

Instead of the emphasis of past years on building better and more powerful machines, the emphasis now is on how to harness the full power of the existing hardware through improved software design. The promise is that the existing machines could do the job much better—more easily, more efficiently—if software were better designed.

And this promise, in turn, leads straight into several key issues that are facing software developers today. What, exactly, constitutes a better design? Of the various approaches that software design can take, which will be most effective in helping users access the full potential of their machines?

Currently software developers face five major issues. None has easy

answers. The stand that each of the major players in the field chooses to take on these issues—and the degree to which the ultimate judge, the user marketplace, accepts each stand—will determine the direction of software design.

A great deal of money will be invested in these choices. The cost of developing a fully integrated family of applications is enormous. Apple talks of investing \$50 million to develop a complete applications family; Xerox views the job in terms of hundreds of man-years. Therefore, each software developer is going to have to take a good hard look at each of these issues and make its choice with great care. A wrong choice will be costly at best; at worst, it could spell financial disaster.

In this article, I'll examine today's central software issues, analyze the pros and cons of the possible choices within each issue, and hazard some guesses as to which directions will prove to hold the key to the software packages of the future.

Integration

Integration has been a byword in the software industry for some time. But the issue here is not superficial integration. I am not talking about taking various products and calling them by similar names. I am not even talking about moving the data back and forth between the products through some sort of low-level

numeric description, where special commands must be given each time the user wants to move data from one application to another.

Such an approach, although better than no integration at all, presents the user with two major problems. First, special commands take considerable time and effort, both in the initial learning and in their application each time the data is to be moved. Worse yet, with this type of integration, important information about the data is lost. Take sales data, for example. In a particular application, users may have described sales by time period (daily, weekly, or monthly), by sales unit (sales rep, product line, or division), and by the form in which they want to print it. With today's level of integration, if they try to move this data from one application to another, they generally will lose some of these important descriptors. The data will be devoid of its full structure.

The two key features of real integration, then, are that it must capture all data descriptors and it must be automatic. That is, to get two applications to work together, there should be no need to continually move the data back and forth manually. If, for example, users need to combine data from their balance sheets and their income statements to do monthly reports, they should be able to specify what data they want the reports to include and in what format

This month the BYTE West Coast editors relinquish their forum to Bill Gates. As chairman of the board of Microsoft Corporation, Gates directs the efforts of one of the microcomputer industry's major software houses and has some definite opinions about the arrival of the soft revolution.

it should be printed. The rest should be automatic—graphs, charts, and all—without any need to go back in and reinput or redescribe the data.

This is how fully integrated software will work. But the big question is, how do you get there? Basically, two possible approaches exist: either build one single application that does everything or else find better ways of moving data between separate applications.

The first approach has a definite appeal, in view of the fact that no one has yet developed a way of moving data between applications in a high-level form. But there are three significant drawbacks to the idea of building a single applications package that does it all.

First, there is the problem of specialized expertise. Even if one software developer had the expertise to build a complete set of generic applications—time scheduling, project scheduling, database development, electronic spreadsheets, and the like—it would be impossible to find a single vendor who had the expertise to build all the necessary vertical applications. And vertical packages specific to different professions or companies are going to be a major segment of the software market. This need, then, points to the importance of developing an approach to integration that lets different parties with specialized types of expertise come in and provide specific vertical applications of the various packages.

A second problem with the approach of developing a single application that does it all is that it requires the selection of a single data structure. Because a data structure that is ideal for one application may be clumsy and inefficient for another, the net effect of this approach is that it compromises individual applications. For example, an in-memory data structure that is well suited to a spreadsheet application may be poorly suited for a database package. In fact, it may be totally unusable. If users want to develop graphs from the data stored in all the separate cells of a spreadsheet, for example, and they have to move the cells around

and give a special set of commands each time they need graphs drawn (or, alternatively, find a macro string that will accomplish the same end), they are not going to be likely to use the application very frequently. Clearly, different applications require different data structures to make them easy to use.

The third difficulty with the single-application approach is that the command structure could easily become overstrained. The number of different commands and decision trees could become a significant problem.

For all of the above reasons, Apple and Microsoft are in agreement that the best solution is to have multiple products that can easily pass data back and forth. This doesn't mean that the products cannot be priced as a single package, or that they can't all be on the screen at one time. But it does mean that they will be based on different data structures and will use different command structures.

User Interface

A second crucial decision area facing software developers today involves the development of standards for user interfaces. Developers are in general agreement on some of these issues. For example, it is generally accepted that packages should include online "help" files so that users can immediately call up a piece of help text that is designed for the specific context in which they find themselves. Similarly, menus written in standard English and full-sentence prompts are generally accepted. Visicorp, for example, is moving away from the use of coded commands (/) and toward the use of English words.

The big issue today in the area of user interfaces is the introduction of graphics. To many people, graphics implies the drawing of bar charts, isometric charts, etc. But the graphics issue is, in reality, far broader than that.

The question is how to present data on the screen. So far, companies have been fairly confined in how they use the screen to present data. For a long time, they could only put characters (and monospaced ones, at that) in specific positions on the screen. This

may not seem like a problem at first glance. But stop and think for a minute: if every time you went to use a piece of paper or a chalkboard you had to take little letters and place them where you wanted them, wouldn't you find this approach to be restricting? You might find yourself using the paper or chalkboard a great deal less than you now do, when you have the freedom to put arbitrary images there in any form.

The new graphic technology, with its use of pixels and bit-mapping, is bringing this same richness to the computer screen. The ability to view the screen as a piece of paper and to put arbitrary images on it means that graphics are going to be used for a great deal more than just drawing graphs. Icons, for example, tell the user what is happening in a much more compact and compelling way than words. Cursor displays to show users their positions are another form of visual feedback. For example, when users are deleting something, the screen could show scissors moving around the material being deleted. Even graphs and diagrams will be revolutionized by the new graphics technology because the time and effort required to produce them will be significantly reduced. In fact, what the new graphics technology represents is a revolution in user interfaces.

The bottom line is that graphics are going to be a standard part of all computers. No machine that costs more than \$1000 will be without a built-in bit-map graphics screen. And the software analog of that hardware statement is that, one year from today, no decent application software family, no decent language family, and no decent operating system will be without extremely high level support for this type of graphics capability. It will be no small task for the software developers to achieve this graphics integration, but it is a necessary task. Furthermore, the graphics capability is not going to be in the form of add-on packages that users go out and buy after they have bought their computers: it will be part of the definition of the machines themselves. As such, it will require

very high level primitives to allow the user to easily access the graphics capabilities.

As the above observations indicate, software developers are going to have to agree on some user-interface standards to allow the full power of this graphics revolution to be felt. First, they will need to develop some standards for incorporating the graphics capability into the machine. Apple is already moving in this direction with its development of a strong operating system as a foundation for such built-in features. Second, they will need to agree on some high-level operating system commands to make the graphics capabilities readily accessible to the user.

Data-Storage Metaphors

Selection of the most appropriate data-storage metaphor is one of the toughest issues facing the software industry today. Basically, this term refers to the way the user perceives the storage of data within the system. Take Apple's Lisa system, for example, which is supposed to be capable of being learned in 20 minutes. Learning the spreadsheet application is going to be easy only for people who are used to working with formulas—people who like formulas, who understand them, and who understand how they can work together in an interdependent fashion. A data-storage metaphor that is based on placing formulas in cells of a spreadsheet is never going to be easy for most people to learn, regardless of how the system is dressed up with easy-to-remember icons, simple English commands, and so forth.

Xerox, on the other hand, uses a linear, document-oriented metaphor. It includes different types of frames (text, graphics, and so forth), but the orientation is still that of a document, which is scrolled through in linear fashion.

The direction that Microsoft is taking is toward a database metaphor. We undertook a study within our own offices to look at the ways people ask about and record data. Our findings showed that the data itself is the key; people generally take a database ap-

proach in recording and accessing information. Someone wanting sales figures for the previous year, for example, would not create a spreadsheet with empty cells and then send it to the accounting department to have the cells filled in. Rather, the person would start with the data that he had and request the additional data needed to complete the picture.

You can see that the metaphor question is entirely separate from concepts such as graphic icons or windows. It is also a much more difficult issue to deal with. The effort, however, will definitely be worth our while: it is in this area, more than any other, that we can make the breakthroughs that will allow the ordinary user to view the computer as simple. A software approach built around the right metaphor will allow users to walk up to the machine, immediately see the data that they have put into the system, and then easily choose the applications that will allow them to view that data in the formats they need—all without having to refer to files, spreadsheet cells, formulas, or any other complex constructs.

Tying Personal Computers to Mainframes

A fourth major concern that software developers need to address is the growing interest in tying personal computers into mainframes. Because of the significant differences among mainframes, this is no simple matter. Mainframes—even those made by the same vendor—have different file handlers, different communications software, and different operating systems. The IBM 370 alone has at least six major operating environments and, within each of those, multiple databases. Creating the software that will allow a personal computer to tie into such a machine will not be a trivial task.

The problem is not simply tying two machines together. That has already been done: software exists that will turn the personal computer into a terminal, ignoring its local intelligence.

The difficulty is to create a method of tying the two together that will allow automatic database querying.

Users should not, for example, have to know JCL (job-control language) to access data from the mainframe. Nor should they need to learn a complex set of command structures. Rather they should be able to query the computer for data anywhere in the system and have the system itself use its intelligence to retrieve that data. In fact, the way the data was initially described in the dictionary should tell the system where to go to get it—whether to go, for example, to the mainframe, Compuserve, or Dow Jones. Resolving this software problem will not be easy, but it must be accomplished; the increasing use of personal computers in large organizations makes this a central concern today.

Expanded Definition of an Operating System

An important development that you will be seeing in the near future is a greatly expanded definition of an operating system. Microsoft, for example, as the vendor of one of today's most popular operating systems, MS-DOS, is planning to incorporate an increasingly higher number of functions into that system. Graphics capabilities, user-interface capabilities, networking—all will be incorporated into the operating system. Instead of these functions being considered add-on products, they will automatically be a part of every machine. This means that applications writers will be able to assume that these functions are there and design their packages accordingly.

The Soft World Is Here

As the above observations indicate, the innovation taking place in the world of computers today originates with software. No longer do you need to go out and build better, more powerful hardware to achieve productivity improvements: you simply develop a new software package, and people can put it to use immediately in their existing machines. The revolution is here—and it is soft. ■

William Gates is chairman of the board of the Microsoft Corporation (10700 Northup Way, Bellevue, WA 98004).

The 8086—An Architecture for the Future

Part 3: Instruction Set Continued

Program transfers, string manipulations, and processor-control instructions are covered

by Stephen A. Heywood

In the previous two articles, I introduced the 8086 instruction set and demonstrated how it began to fulfill programmers' needs. Memory variables can be designated as the destination of most operations, and the addressing modes support the needs of compilers. In this final part, I look at 8086 program transfers, string manipulations, and processor-control instructions.

Program Transfers

Instructions are fetched from memory using the CS register as the segment register and the IP register as the offset. The program-transfer instructions (see table 1) can change the contents of the CS and IP registers or just the IP register.

For example, the JMP (jump) instruction does an unconditional transfer to the target location. The two major forms of JMP are direct and indirect.

The direct JMP instructions have three forms: short, near, or far. The short and near JMP instructions add

a displacement contained in the instruction to the IP register. Using a displacement instead of a direct address for these jumps helps the code become position-independent. This code can be located anywhere in memory because these jumps are a displacement from the current instruction instead of an absolute address. The short form contains a 1-byte displacement that adds to the IP register in order to jump +127 or -128 bytes from the next instruction.

The near form contains a 2-byte displacement that adds to the IP register for jumps within a 32K-byte range. It can also be used to jump anywhere within the current program segment.

As noted earlier, a segment can be as long as 64K bytes. This is due to the offset being given by a 16-bit register. This addressing method makes the segments appear circular, as opposed to linear for earlier microprocessors. For example, if a

Mnemonic	Description of Operation
JMP target	Jump to target location
Jcond target	See table 2
LOOP target	Loop
LOOPE/LOOPZ target	Loop while equal/loop while zero
LOOPNE/LOOPNZ target	Loop while not equal/loop while not zero
JCXZ target	Jump if CX = 0
CALL target	Call procedure
RET optional-value	Return from procedure
INT type	Interrupt
INTO	Interrupt if overflow
IRET	Interrupt return

Table 1: The 8086 program-transfer instructions are used to modify the values in the CS and IP registers or the IP register alone.

TCS Heart of TEXAS COMPUTER SYSTEMS

LEADER in MAIL ORDER DISCOUNTS!

800 433-5184

Texas 817/274-5625

IBM Personal Computer

APPLE

INTERNAL DISKS FOR IBM
Tandon Internal Disk-160K SCALL
Tandon Internal Disk-320K SCALL

HARD DISKS FOR IBM
Complete 5 Meg. Systems from ... \$1550
Multi-computer Network Systems.

QUADBOARD FOR IBM
Includes 64K to 256K additional memory
Serial & Parallel Port and Calendar Clock

PRINTERS FOR IBM
STAR and EPSON SCALL
NEC 3550 Spinwriter SCALL

MONITORS
Med Hi Res-Green Comrex \$89
High Res-Green BMC from \$89
High Res-Color PGS SCALL
Matches IBM PC
Low Res-Color-Taxon Vision 1 SCALL
High Res-Color-Taxon Vision 1 SCALL
High Res-Green-Taxon SCALL

First DISK DRIVE includes controller, DOS
3.3, cables and manual SCALL
Second DISK DRIVE w/ cable SCALL

APPLE to EPSON card and cable
APPLE TO GEMINI card and cable
Z 80 CARD SCALL
RAM CARD SCALL
Printer Interface Cards SCALL
Graphic Printer Interface Card SCALL
Graphic Spooler Interface Card
available with 16K to 64K



FOR IBM, APPLE II AND APPLE III
SPECIFY INTERNAL/EXTERNAL
5 megabyte hard drive SCALL
12 megabyte hard drive SCALL

TCS MODEL III 48K 2 DISK

Systems come with 180 day warranty.

\$1444

With standard 40 track
double density drives
Over 340,000 bytes
Includes TDOS

\$1644

With 2 dual headed 40
track dbl. density drives
Over 730,000 bytes
Includes DOSPLUS 3.4
(\$150 value)

Fully assembled and tested systems that are software compatible and functionally identical to Radio Shack units sold at computer stores for hundreds more.

- CONTROLLER BOARDS are high quality double sided epoxy boards with gold plated contacts
- POWER SUPPLY is the finest switching type available.
- MOUNTING HARDWARE includes power and data cables.
- DISK DRIVES are Tandon, the same ones used by Radio Shack...40 track, double density, with a 5 millisecond stepping rate.

TCS MODEL III DISK EXPANSION KITS

- 1 Controller, Power Supply, Mounting Hardware & Instruction \$279
- 2 Controller, Power Supply, Mounting Hardware & one 40 track Tandon Drive \$478
- 3 Controller, Power Supply, Mounting Hardware & two 40 track Tandon Drive \$677
- 3A Kit 3 but with two 80 track drives (dual 40's) \$879
- 3B Kit 3 but with two 160 track drives (dual 80's) \$1099

TCS Model III and Color Computer

Ask about the Green or Amber CRT for your customized Model III

CORVUS

HARD DISKS from \$1889

5 Megabyte Hard Drive SCALL
10 Megabyte Hard Drive SCALL
20 Megabyte Hard Drive SCALL

Add 5, 10 or 20 Megabytes of storage to your TRS-80 Model 1, Model II, Model III,
Model 12, IBM, Apple, Atari, Heath, Zenith, Intertec, S100, Osborne, Eagle
Commodore 64, Xerox, Superbrain, Z89/90, DEC LSI-11, NEC PC-8001, and more.

One or several computers can share A HARD DISK

Ask about OMNINET for your Apple or IBM PC.



Dedicated
To Being No. 1!

FEATURES

- * 100 CPS
- * 9X9 Dot Matrix
- * True Decenders
- * Super Script-Subscript-Underlining
- * Friction and Tractor
- * Programable Line Spacing
- * 99% Compatible with software written for No. 1 Printer.
- * High Res. Bit Image Block Graphics
- * Backspacing-Doublstrike-And More
- * 5, 6, 8 1/2, 10, 12 and 17 Pitch
- * Free 2.3K Buffer

Extended Six (6) Months Factory Warranty--FREE!

Gemini 10 (9 inch Carriage) Friction and Tractor SCALL
Gemini 15 (15 inch Carriage) Friction and Tractor SCALL
Serial Interface SCALL
Apple Card and Cable SCALL
Commodore Interface SCALL

COMMODORE 64

VIC 20--DISK DRIVES--MONITORS
DATASETTES--SOFTWARE
ACCESSORIES

Call For Current Pricing Information.

PRINTERS

TCS has the LOWEST PRICES on IN-STOCK PRINTERS

LETTER QUALITY PRINTERS

C.I.TOH F-10 (40 CPS)
DAISY WHEEL II (RS)
NEC 3510-3550
NEC 7710/7730
BROTHER COMREX

MATRIX PRINTERS
EPSON-MX & FX MODELS
C.I.TOH 8510/TEC/PMC
DMP 100
DMP 200
DMP 400
DMP 500
DMP 2100
ANADDEX 9501-A
CENTRONICS 352/353
OKIDATA PRINTERS

PRINTER CABLES AND INTERFACES AVAILABLE.
CALL FOR CURRENT PRICING INFORMATION.

Tandon

TCS DRIVE CABINET is industrial grade heavy guage metal, safely fused, and comes with gold plated external connector with extender cable

1 DRIVE in Cabinet

40 track single sided \$249
80 track (dual sided 40 track) \$329
160 track (dual sided 80 track) \$449

1 DRIVE/Double Cabinet

40 track single sided \$289
80 track (dual sided 40 track) \$389
160 track (dual sided 80 track) \$499

2 DRIVES/Double Cabinet

40 track single sided \$489
80 track (dual sided 40 track) \$639
160 track (dual sided 80 track) \$849

Drives in cabinets come assembled/tested with power supply. Order cable separately

BARE DRIVES ONLY

40 track single sided SCALL
80 track (dual sided 40 track) SCALL
160 track (dual sided 80 track) SCALL
8 inch Slimline sgl/dbl sided SCALL
Winchester Hard Drives 5-30 Meg SCALL

Smith-Corona® TP-I

Parallel/Serial \$535

TEXAS COMPUTER SYSTEMS

P.O. Box 1327 Arlington, Texas 76004-1327

TECHNICAL ASSISTANCE 817/274-9221

ORDER STATUS 817/277-1913

TELEX/TWX/Easylink ELN 62100790

★ 800 433-5184

No tax out of state. Texans add 5%. Prices subject to change at any time.

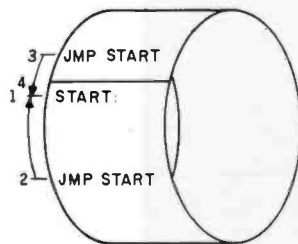
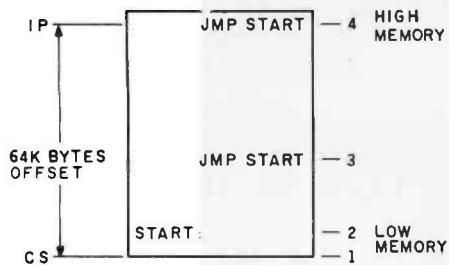

Figure 1: A near JMP, which is greater than 32K bytes from the target location, uses a forward JMP with a positive displacement; if less than 32K bytes from the target, it uses a backward JMP with a negative displacement.

displacement of +5 is added to the contents of IP, which contains a hexadecimal FFFE, then the IP register would contain a hexadecimal 0003 after the operation. Figure 1 graphically demonstrates this circular concept. Notice that a jump from the end to the beginning of the code area actually jumps forward instead of backward. Because the JMP instruction is more than 32K bytes from the beginning, the shortest distance is forward.

The far JMP replaces both the CS and IP registers with the 5 bytes contained in the instructions. This allows a jump to the beginning of a new segment. Modular programming takes advantage of this capability. Recall that modular programming splits up the programming task among several programmers and puts the final project together using a linker. To transfer control from one module to another, you would employ a far JMP.

Another use for the far JMP is after a reset. Delivering a reset to the 8086 causes the following: IP, DS, SS, ES, and the flags are cleared; the CS register reads hexadecimal FFFF; and the remaining registers are left alone. With CS equal to FFFF and IP equal to 0, the first instruction will be

fetches from FFFF0. You would put a far JMP to the beginning of the program at this location.

Indirect-near JMP instructions transfer the contents of a general register or the contents of a memory location, using the addressing

modes, to the IP register. This lets you use jump tables according to the values calculated. Figure 2 illustrates the use of an indirect jump on a value that has been input from a port to jump to a proper routine.

The far-indirect JMP uses the contents of a double-word memory location, using the addressing modes, to load the CS and IP registers. The first word transfers to the IP and the second word to the CS.

Conditional-jump instructions jump on the status of the 8086 flags at the time the instruction is executed. The tested flag conditions are shown in table 2. If the condition is TRUE, then the jump takes place; if the condition is FALSE, then the next instruction is executed. All conditional jumps are short jumps. Therefore, the target must be within -128 or +127 bytes of the next instruction. If you want to jump to a farther target, you would use the opposite condition to jump around a near JMP to the target location.

Conditional transfers can be divided into three categories: signed, unsigned, or either. Signed-conditional jumps look at the Overflow and Sign flags; the unsigned versions look at the Carry flag. Most of these instruc-

```
TABLE    DW    ERROR    ;This sets up a table of offsets to
          DW    ROUTINE1 ;the printer routine
          DW    ROUTINE2 ;DW means to define as a word
          DW    ROUTINE3
          DW    ROUTINE4
          DW    ROUTINE5
```

```
;This will input from a keyboard at port 0 a value from 1-5
;in ASCII and jump to the routine for that key. If the key
;is anything else it will go to an error routine.
```

```
START:   IN    AL,0      ;Get value from keyboard at port 0
          SUB    AL,30    ;Subtract hexadecimal 30 to change from ASCII
          ;to a value
          CMP    AL,5     ;See if value is anything but 0-5
          JBE    INRANGE  ;If 0-5 then pointing correctly
          XOR    AL,AL    ;If not 1-5 then make it zero to go
          ;to error routine
INRANGE: XOR    AH,AH    ;Clear high byte to make word
          MOV    SI,AX    ;Place in index register to address
          SAL    SI,1     ;Double value for word indexing
          JMP    TABLE[SI] ;Jump to the routine whose offset
          ;is TABLE plus SI
```

```
ERROR:   _____ ;Routines would go here
ROUTINE1: _____
ROUTINE2: _____
ROUTINE3: _____
ROUTINE4: _____
ROUTINE5: _____
```

Figure 2: Using a JMP table.

HITACHI

A 30 MHz SCOPE AT A 15 MHz PRICE

\$549.95

V-302F 30MHz

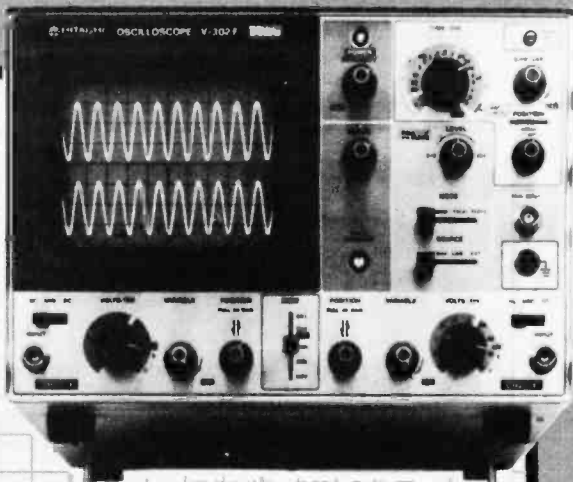

DUAL TRACE
W/DELAY

QUANTITIES ARE LIMITED

SPECIFICATIONS

Vertical Deflection Sensitivity	5mV/div to 5V/div $\pm 5\%$, 10 calibrated steps 1mV/div to 1V/div $\pm 6\%$ (When using $\times 5$ amplifier) Uncalibrated continuous control between steps 1: < 2.5 (provide with click-positioning function)		
Bandwidth	DC to 30MHz, $-3dB$ (at 4 div) DC to 7MHz, $-3dB$ (at 4 div) (When using $\times 5$ amplifier)		
Rise Time	12ns (for $\times 5$) 70ns typ		
Signal Delay Line	Permits viewing leading edge of displayed waveform		
Max. Input Voltage	600Vp-p or 300V (DC + AC peak) at 1kHz)		
Input Coupling	AC, GND, DC		
Input Impedance	Direct 1M ohm, approx. 30pF		
Operating Modes	CH1, CH2, DUAL, ADD, DIFF		
X-Y Operation	CH1: X axis, CH2: Y axis		
Sensitivity	5mV/div to 5V/div (when using $\times 5$ amplifier: 1mV/div)		
Horizontal Deflection	AUTO, NORM, TV (+), TV (-)		
Trigger Modes	CH1, CH2, LINE, EXT		
Trigger Source	AC		
Trigger Coupling	TV sync-separation circuit		
TV Sync	L div or more (V sync-signal)		
Internal	1Vp-p or more (V sync-signal)		
External			
Trigger Sensitivity	Frequency	Internal	External
	20Hz to 5MHz	0.5div	200mV
	5 to 30MHz	1.5div	800mV
AUTO Low Bandwidth	30Hz		
Trigger Slope	\pm		
External Trigger Input	Input impedance: approx. 1M ohm, 30pF or less Max. input voltage: 100V (DC + AC peak at 1kHz)		
Sweep Time	0.2 μ s/div to 0.2s/div, $\pm 5\%$ 19 calibrated steps Uncalibrated continuous control between steps 1: < 2.5 (provided with click-positioning function)		
Sweep Time Magnifier	10 times ($\pm 7\%$)		
Max. Sweep Time	100ns/div (20ns/div and 50ns/div, not calibrated)		
Power Requirements	100/120/220/240V $\pm 10\%$ 50 to 60Hz approx. 40W		
Dimensions	Approx. 275(W) x 190(H) x 400(D) mm		
Weight	Approx. 8.5kg		

FEATURES

- 1 mV/div high sensitivity design. Effective for measurement of weak signals.
- Employs TV sync separator circuitry with one touch synchronization of both TV horizontal and vertical signals.
- Built-in signal delay line enables front observation of fast rising waves.
- X-Y operation convenient for measurement of phase difference between two signals.
- Delayed sweep function with one touch control 10X magnification.
- Trace rotation system for easily adjusting trace inclination caused by terrestrial magnetism.
- Fine adjusting click positioning function enhances measuring efficiency.
- Signal output: CH1 output terminal to Frequency Counter, etc.
- Z axis input provided — possible to use as CRT display.
- One touch shifting of waveform slopes for easy observation of rise and fall of waves.

Price does not include probes.
Probes \$50, a pair when purchased with scope. \$10. shipping within continental U.S.

We don't just take orders - we ship orders -
Advance Electronics endeavors to keep everything
we advertise in stock for immediate delivery.

- Mastercharge & Visa shipped within 24 hours.
- Bank checks or Money Orders shipped within 24 hours.
- Personal checks — please allow 3 weeks for check to clear.
- All prices plus shipping charges. Please call for appropriate charges. Use our toll free number.
- New York State residents add appropriate sales tax.
- PRICES SUBJECT TO CHANGE WITHOUT NOTICE.



TOLL FREE HOT LINE
800-223-0474

THE TEST EQUIPMENT SPECIALISTS

26 WEST 46th STREET, NEW YORK, N.Y. 10036 212-730-7030

ADVANCE ELECTRONICS

The 80186—

The 8086 is a popular microprocessor being used by hardware designers in many different systems. In fact, in varied applications system designers employ the same components. For example, an interrupt controller supplies the external interrupt type number for multiple interrupts. A clock generator furnishes the 8086 and system clocks as well as buffering the reset and ready input signals. Chip-select logic chooses different memory blocks and input/output devices. Often, these devices run at different speeds. Therefore, wait-state generators insert wait states in the microprocessor for accessing the slower devices. Timers and counters handle the timing and counting of events and tasks. To transfer data quickly between input/output devices and/or memory devices, DMA (direct memory access) controllers find widespread use. Chips supply control signals and give added drive to the data bus. However, all these components take up board space, and their interconnections make for a complex design and possible future problems. Consequently, Intel designed and manufactured an improved version of the 8086 microprocessor, called the 80186.

The 80186 contains the following hardware on one 68-pin chip:

- 8-MHz enhanced 8086 microprocessor
- programmable multilevel interrupt controller for as many as five external and three internal sources
- clock generator for internal and external clocks
- programmable memory and input/output chip selects for as many as six independent memory blocks and as many as seven peripherals
- three 16-bit programmable timer/counters, two external and one internal
- two independent programmable DMA channels for transfers up to 2 megabytes/sec per channel
- data-bus transceiver for added drive
- local bus controller for control signals

These 80186 devices can be addressed in the input/output space or in the memory space for programming purposes. The control registers for the interrupt controller, the timers, the DMA channels, and the chip-select logic are grouped together in a 256-byte block. The 80186 has one additional register, the relocation register. It

Mnemonic	Jump if	Condition Tested
Signed		
JG/JNLE target	greater/not less nor equal	((SF XOR OF) OR ZF) = 0
JGE/JNL target	greater or equal/not less	(SF XOR OF) = 0
JL/JNGE target	less/not greater nor equal	(SF XOR OF) = 1
JLE/JNG target	less or equal/not greater	((SF XOR OF) OR ZF) = 1
JO target	overflow	OF = 1
JS target	sign	SF = 1
JNO target	not overflow	OF = 0
JNS target	not sign	SF = 0
Unsigned		
JA/JNBE target	above/not below nor equal	(CF OR ZF) = 0
JAE/JNB target	above or equal/not below	CF = 0
JB/JNAE target	below/not above nor equal	CF = 1
JBE/JNA target	below or equal/not above	(CF OR ZF) = 1
Either		
JC target	carry	CF = 1
JE/JZ target	equal/zero	ZF = 1
JP/JPE target	parity/parity even	PF = 1
JNC target	not carry	CF = 0
JNE/JNZ target	not equal/not zero	ZF = 0
JNP/JPO target	not parity/parity odd	PF = 0

Table 2: The conditional transfers jump on the status of certain flags and can only be short jumps.

tions have more than one mnemonic. Again, this is to aid documentation purposes.

The conditions of greater and less refer to signed values; the conditions of above and below refer to unsigned values. These conditions should be used after you have done a CMP or a SUB instruction to ensure that you have the right flag conditions. You can see the difference between these two conditions by an example. If you compare the following hexadecimal bytes, FF to 00, and treat them as signed numbers, you are comparing a -1 to a 0 and determining that FF is less than 0. But if you compare these same numbers and treat them as unsigned numbers, you would find that 255 is above 0. This means that the conditional jump that you would use depends on how you treat the numbers.

Most programs use some type of software loop to perform such tasks as adding a value to a group of locations or a delay. Included in the 8086 instruction set are three instructions to make looping easier. These LOOP instructions use the CX register as a counter. They decrement the CX register and transfer to the target location if CX is not equal to zero. Otherwise, control transfers to the next instruction. Basically, this in-

struction replaces the following two instructions:

```
DCR    CX
JNZ    target
```

Except for one difference, no flags are affected by the LOOP instructions. Like the conditional transfers, LOOP instructions are only short transfers. Assembly-language programmers please note the following. If you like to use LOOP as a label in your programs, you might get an error from the assembler if you try it with the 8086.

The two conditional LOOP instructions are LOOPE (loop while equal)/LOOPZ (loop while zero) and LOOPNE (loop while not equal)/LOOPNZ (loop while not zero). These two instructions have an alternate way of falling out of the loop. They decrement the CX register and transfer control to the target if CX is not equal to zero and the Zero flag is set for LOOPE or is cleared for LOOPNE.

The program will fall out of the loop if the CX register is zero, or prematurely fall out if the Zero flag is cleared for LOOP while equal/zero or if the Zero flag is set for the LOOP while not equal/not zero. Because the LOOP part of the instruction does

A Lot of Hardware in One Package

locates this block in the input/output or memory space, contains the most significant 16 bits of the address where this block is located, determines the condition of the interrupt controller, and determines whether to interrupt if an ESC instruction comes in.

The 80186's microprocessor has been enhanced for added performance over the 8086. For example, the 8086 calculates addresses (segment + base + index + displacement) in an internal microcode routine. The 80186 uses a dedicated hardware adder to speed up address calculations. Also included in the 80186 is the hardware for 16-bit integer multiply and divide to speed up these instructions more than three times faster than the 8-MHz 8086. Furthermore, string manipulations have been streamlined by doing the string overhead of decrementing CX and checking flags in parallel so they execute as fast as the memory can handle them (up to 2 megabytes/sec). Multibit shifts and rotations execute each shift or rotation at a 1-bit/clock cycle.

The 80186 has the same instruction set as the 8086; therefore, code written for the 8086 can run on the 80186. Ten additional instructions are also included in the 80186, as listed in table 1.

For example, you can push an immediate 16-bit value or a sign-extended 8-bit value on the stack. This instruction speeds up the previous 8086 method of moving an immediate value to a register and then pushing that register on the stack to pass an immediate value as a parameter to a procedure.

If you want to save all the general registers (AX, BX, CX, DX, BP, SP, SI, and DI) at the beginning of an interrupt routine to use them in the routine, the 80186 has an instruction called PUSHA (PUSH all) to do all this storage in one instruction. Instruction POPA (POP all) does the reverse and is used at the end of the routine.

If you want to multiply by an immediate value in the 8086, you move it into a register or a memory location first and then multiply. In the 80186, instruction IMUL (integer multiply immediate) can multiply any 16-bit general register or memory location as the source with an immediate 16-bit integer (or a sign-extended 8-bit integer) and place the 16-bit product in any 16-bit general register as the destination.

For multibit shifts/rotations, you can

shift or rotate by the count held in the CL register for both the 8086 and the 80186. However, the 80186 also lets you specify the count by an immediate value in the instruction (e.g., SAL BX,5).

String instructions let you manipulate blocks of memory. The 80186 has two added string instructions (INS and OUTS) for input/output devices. Instruction INS (input string) stores in memory, pointed to by the ES segment register with DI offset, the block of bytes or words input from the device whose port address is in the DX register. Instruction OUTS (output string) outputs to the device, whose port address is in the DX register, the block of bytes or words in memory pointed to by the DS segment register with SI offset. You can use these instructions with or without a REP prefix, and DI and SI are updated the same way as string instructions.

Block-structured high-level languages (such as Pascal) create a stack frame for local variables at each procedure level and copy pointers to access a previous level's variables. The 80186 instruction ENTER is used by a compiler to set this up. The first operand says how much room (in bytes) to set aside on the stack for local variable space. The second operand equals the level to determine how many pointers to copy to this procedure's stack area. Instruction ENTER also follows the convention of pushing BP and loading BP with SP. The LEAVE instruction does the opposite and has no operands.

The BOUND instruction checks the array-index register specified in the instruction against a boundary to determine whether it is within limits. The array-

index register is compared with a two-word memory block whose offset is in the instruction. The first word contains the lower limit that the index register can contain, and the second word contains the upper limit. If this register is out of the boundary, an automatic interrupt type 5 is generated. Any general register can be specified, but you would usually use BX, BP, SI or DI because they are in the addressing modes.

Notice that a new interrupt type is defined by the 80186. Other interrupts are also used by the 80186 that were previously reserved for future use by the 8086. If the 80186 encounters an undefined op code, an automatic type 6 interrupt is generated. If an ESC instruction comes in and the 80186 is not connected to a coprocessor, the instruction is normally ignored. But if you want to emulate the instruction in software, you would set the bit mentioned earlier in the relocation register. Then, every time an ESC instruction comes in, an automatic type 7 interrupt is generated, and the return address will point to the ESC instruction that caused it. The routine would then emulate the ESC instruction in software by using this information. The timers, DMA channels, and external interrupts have interrupt types associated with them as well.

Building on 8086 experience, enhanced hardware functions make the 80186 a much improved microprocessor for hardware designers because of its reduced component count and interconnections. These advanced features help speed up the execution of software. The added instructions provide additional programming benefits.

Mnemonic

Description of Operation

PUSH immediate	PUSH immediate data
PUSHA	PUSH all general registers
POPA	POP all general registers
IMUL dest, source, immediate	Integer multiply immediate
Shift/rotate dest, immediate	Shift/rotate destination by immediate count value
INS	Input string using DX for port
OUTS	Output string using DX for port
ENTER stack-frame, level	Enter procedure
LEAVE	Leave procedure
BOUND reg,boundary	Check array against boundary

The 80186 has 10 additional instructions added to its 8086-based instruction set for added software capabilities.

HOT PRICES!

FROM SEATTLE

COMPUTERS

Kaypro	CALL
Superbrain QD 64K DS DD	\$2250
Franklin Ace 1000	\$1059
NEC APC 128K	
1 drive, monochrome	\$2200
Columbia PC	CALL
Eagle 11 64K DS DD w/software	\$1795

PRINTERS

Cables made to your order	CALL
Gemini 10x	\$329
Gemini 15x	\$535
Okidata 92	\$529
Diablo 620	\$952
Mannesmann Talley 160L	
10" carriage w/tractor	\$659
Mannesmann Talley 180L	
15" carriage w/tractor	\$861
Daisywriter	
17cps letter quality 48K	\$1149
IDS Prism 80	\$1015
Microbuffer 64K stand alone	\$290
IDS Prism 132 Sprint, 3.4K Buffer	\$1179
IDS Prism 80	\$1015
Microbuffer 64K stand alone	\$290

MODEMS

Hayes 300 baud	\$219
Hayes 1200 baud	\$509
Novation J Cat	\$125
Novation Smart Cat	\$190

MONITORS

Princeton Graphics RGB	\$599
BMC Green	\$85
Amdek Amber	\$169
Amdek Green	\$139
Amdek Color Composite	\$319
Taxan Amber	\$149
Taxan Green	\$143
Taxan 111 RGB 630H	\$549

APPLE PERIPHERALS

ALS CP/M	\$299
ALS Z Card	\$139
Taxan III Interface	\$89
Davong Hard Disk 5MB	\$1599
Apple Dumping	\$95
Grappler Plus	\$125
Grappler 16K Buffer Board	\$125
Modemcard, internal, 300 baud	\$245
Rana Drives	\$295
Micro Sci Drives	\$259
Shugart Drives	\$239
The Filler w/DOS & Copy Utility	\$20
PFS Filler	\$89
PFS Report	\$69
VIP Card p. s.	\$113
Microbuffer 16K	\$212
More than 1000 programs	CALL
Apple Time Card	\$75

IBM PERIPHERALS

AST I/O (no ram) w/1s.1p.c.g.	\$219
AST Mega Plus 64K, 1s. c	\$359
Tandon TM100-2 drive	\$259
Davong 5MB Hard Disk	
Internal	\$1345
Monte Carlo Card new pricing	\$335
Hercules Board	
w/monochrome & graphics	\$549
Peachtext 5000	\$275
Lotus 123	CALL
Multiplan	\$210
Flight Simulator	\$29
Copy 11	\$40
Smartcom Communications, Hayes	\$45
Hayes internal modem	\$459
More! 100's of programs available	CALL

Orders Only 1-800-531-3133

Information: (206) 641-7233

Bank Cards

Prices reflect 3% Cash Discount

Sorry, no COD's.

PACIFIC COMPUTERS

13256 Northup Way #7
Bellevue, WA 98005

not affect the Zero flag, you could precede these conditions with a CMP and make it a condition to fall out of the loop prematurely.

Because LOOP decrements CX first and then checks to determine whether it is zero, you could encounter problems if you enter the loop with CX equal to zero. If you don't check CX for zero before the loop, you would execute the loop 65,536 times. To prevent this problem, you employ the JXZ (jump on CX zero) instruction. It jumps if CX is equal to zero; you could use this to jump around the loop if CX is equal to zero and you don't want to execute the loop so many times.

Procedures

Procedures, a name given to subroutines by high-level languages, are used for often repeated parts of a program. The CALL instruction is used to jump to a procedure, and the RET (return) instruction returns you back to the program. The CALL instruction is like a jump except that it saves the return address, the address of the next instruction following the CALL, on the stack; there is no short form of this instruction. The CALL instruction can be indirect or direct as well as near or far. The near-form CALL instruction places the contents of the IP register on the stack and then adds the displacement in the instruction to the IP register. The far-form CALL instruction pushes both CS and IP on the stack before reloading these registers. This means that the RET instruction must be either far or near. Once a procedure has a far return at its end, you must use a far CALL to the procedure to make sure that the right information is on the stack for the RET instruction.

Often, you need to pass information, called parameters, to procedures. These parameters can be passed in different ways. One way is to pass the parameter in a register, and the procedure would use that register's contents. Another way is to save the parameter in a memory location common to the procedure. A third way is to pass the parameters on the stack and have the procedure

get them and clean up the stack after it is done. To pass parameters on the stack, you can push register contents or the contents of memory locations; this is the most common method used by high-level languages.

Reentrant procedures are those that call themselves, that call another procedure and then that procedure calls it back, or that can be interrupted and the interrupt calls the procedure. Each time the procedure is called, it might require different parameters to work with. If you use the stack to pass these parameters, then each time the procedure is called it has a new stack frame to work with, an area in the stack set aside for a procedure to work in.

Figure 3 shows an example of a calling program that pushes the parameters on the stack and the procedure that utilizes these parameters. The stack frame is also shown as it would look after the BP register is pushed on the stack in the procedure.

Remember from part 1 that the physical address consists of a segment and an offset. The 8086 addressing modes can use the contents of the BX, SI, DI, or BP registers to generate the offset to get data. The BX, SI, and DI registers default to the DS, but the BP register defaults to the SS register as its normal segment register. BP can then be used as the base register to access parameters on the stack. All procedures that have parameters on the stack then employ the BP register as shown in figure 3.

In the sample procedure, you first use PUSH to put BP on the stack to save it and thus not ruin it for another procedure that is using it. Following that, you direct BP to point to the same location as SP with the MOV BP,SP instruction. In this way, you have the BP and SP registers pointing to the same area, namely, the top of the stack. Now you can use the BP register to access the parameters off the stack frame instead of changing the contents of the SP register. Because the SP register is used to point to the top of the stack, and interrupts as well as procedures employ the stack to save the return address, you don't want to mess around with this register.

1-2-3™ FROM LOTUS. IT'LL HAVE YOUR IBM/PC JUMPING THROUGH HOOPS.

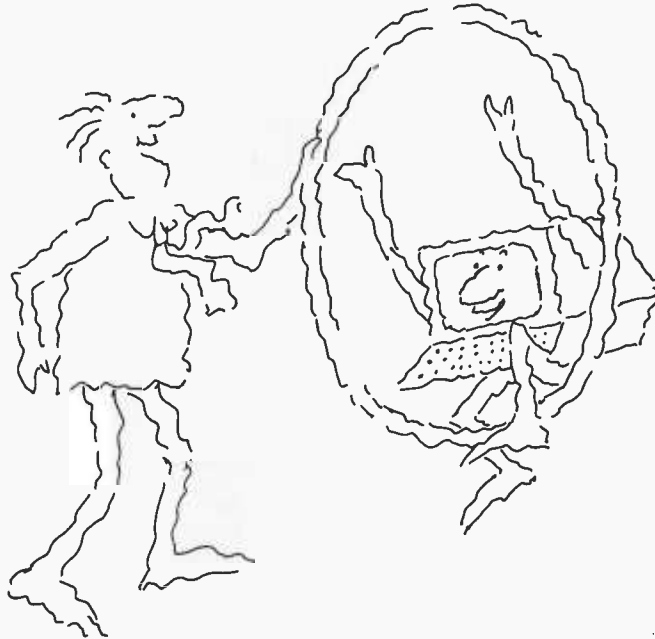

Meet 1-2-3 – the remarkable new software package that puts more raw power at your finger tips than anything yet created for the IBM PC. 1-2-3 actually combines information management, spreadsheet, and graphing in one program that can perform all three functions interchangeably and instantly at the touch of a key. That's power.

To explain: since 1-2-3's information management, spreadsheet and graphing functions reside in memory simultaneously, you can go from retrieval to spreadsheet calculation to graphing instantly, just by pressing a few keys. So now you can experiment and recalculate and look at data in an endless variety of ways. As fast as your mind can think up new possibilities. There's no lag between you and the computer. And that's a new kind of power – power that's greater than the sum of its programs.

The spreadsheet function.
If 1-2-3 were just a spreadsheet, you'd want it because it has the largest workspace on the market (2048 rows by 256 columns). To give you a quick idea of 1-2-3's spreadsheet capabilities: VisiCalc's spreadsheet for the IBM PC offers 15 arithmetic, logical and relational operators, 28 functions and 32 spreadsheet-related commands. 1-2-3 has 15 operators,

41 functions and 66 commands. And if you include data base and graphing commands, it actually has 110!

In addition, 1-2-3 is up to 50 times as fast as established spreadsheets. With all the features you've ever seen on spreadsheets. 1-2-3 also gives you the capability to develop customized applications (with 26 macro keys) and lets you perform repetitive tasks automatically with one keystroke. If 1-2-3 were just a spreadsheet, it would be a very powerful tool. But it's much, much more.

The information management function.

Add to 1-2-3's spreadsheet a selective information management function, and the power curve rises at an awesome rate. Particularly since 1-2-3's information management capability reads files from other programs such as WordStar, VisiCalc and dBase II. So you can accumulate information on a limitless variety of topics and extract all or pieces of it for instant spreadsheet analysis. Unheard of before. Specific 1-2-3 information management features include sorting with primary and secondary keys. Retrieval using up to 32 criteria. 1-2-3 performs statistical functions such as mean, count, standard deviation and variance. It can produce histograms on part or all of the data base. 1-2-3 also

allows for the maintenance of multiple data bases and multiple criteria.

The graphing function.

1-2-3 enables you to create graphs up to six variables using information already on the spreadsheet. And have it on screen in less than two seconds! Once you've made a graph, three keystrokes will display it in a different form. If data on the spreadsheet changes, you can display a revised graph with one keystroke. This instant relationship of one format to another opens up a whole new application area. For the first time graphics can be used as a "what if" thinking tool!

For a full demonstration of 1-2-3's remarkable power, visit your nearby 1-2-3 dealer. For the name and address, call 1-800-343-5414 (in Mass. call 617-492-7171).

Lotus Development Corporation,
55 Wheeler Street, Cambridge, MA 02138.

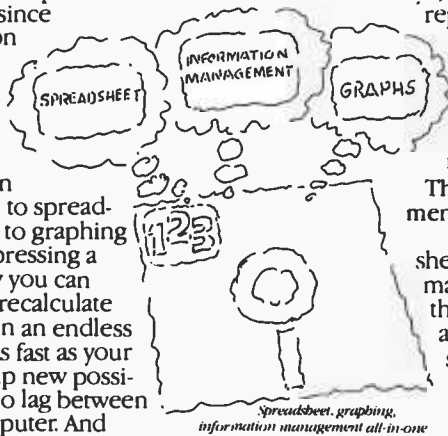

1-2-3 and Lotus are trademarks of Lotus Development Corporation. All rights reserved. WordStar is a registered trademark of MicroPro Inc. VisiCalc is a registered trademark of VisiCorp. dBase II is a registered trademark of Ashton-Tate.

FLIP-IT works!

bookmark by D/Punch™

running out of diskettes?
how many floppies do you have?
only listen to records on one side?
only play tapes on one side?

STOP WASTING HALF YOUR MONEY & MEMORY

EXACTLY.

Why should your single-sided diskettes be readable and writeable only to one side? THESE TIMES DEMAND THAT EVERY DOLLAR YOU SPEND HAVE THE POWER OF TWO

GREAT FOR:

1. Saving storage space
2. Increasing memory
3. Making backup copies
4. Saving money
5. Fun to do



5 1/4" FLIP-IT

Now you can easily convert your single-sided Floppies into Flippies (diskettes) using FLIP-IT's pat. pend., clumsyproof, leeryproof, conversion Kits. Works with single, double or quad density — hard or soft sector. With FLIP-IT, there is:

NO NEED TO:

1. Measure.
2. Make alignment marks.
3. Take media out of jacket.
4. Alter your hardware.
5. Buy additional software.

"FLIP-IT was very easy to use... converted... four boxes of diskettes in less than one half hour... Used other side... No Problems."

John DeMeritt, Belmont, MA

"No errors in reading or writing data in spite of heavy use... will continue to recommend to my friends and clients."

Joseph Wietette, Brookline, MA

When ordering, remember to specify your computer system.

- a) 5 1/4" FLIP-IT: for all 5 1/4" computers incl. Apple, IBM, Osborne, Atari, Radio Shack, Commodore, Victor, Kaypro, Franklin & more only \$29.95
- b) 8" FLIP-IT: for 8" computers incl. IBM, Wang, Altos, Radio Shack, DEC, DG & more only \$34.95
- c) Labels: (self-sticking, 100 ea.) only \$3.00
- d) Write Protect/Enable Tabs: (100 ea.) \$2.65
- e) Hub-Reinforcer Kit: (positioning tool for hub-spining) 5 1/4" disks: \$10.99 8" disks: \$12.99
- f) Hub-Reinforcer Rings: (50 rings ea. for hub-spining) 5 1/4" disks: \$5.85 8" disks: \$7.20
- g) Disk Sleeves: (Lint free, 10 ea.) 5 1/4" disks: \$2.55 8" disks: \$3.85

Add \$3 for ship & hdlg (AK, HI, PR, Canada add \$5.50. Foreign countries add USD 10.50) — Mass. Res. add 5% tax. Send Check, Money Order to:

D/Punch Co. (BB)

P.O. Box 201, Newton Hds, MA 02161
Telex: 4991009 CHTR TECH. INFO: (617) 964-2126



TOLL FREE 24 HRS ORDER LINE
1-800-227-3800 ext. 128

copyright 1983 D/Punch Corp.
We acknowledge all trademarks
Dealer inquiries invited.

For your FREE bookmark for your manuals, send us a stamped, self-addressed envelope. **SPECIAL**

FLIP-IT works!

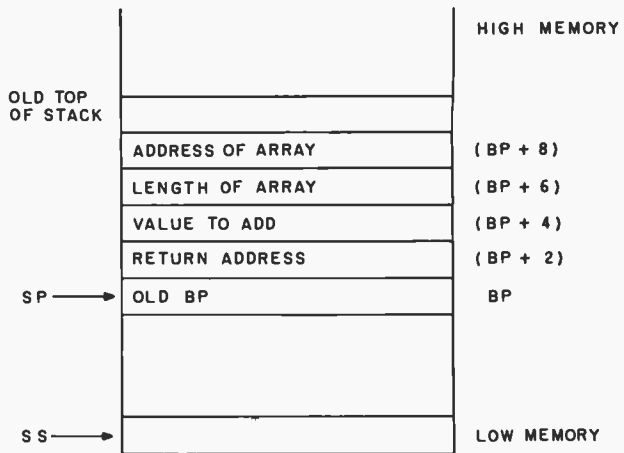

```

;Calling program
LEA    AX,ARRAY ;offset to beginning of array
PUSH  AX
MOV   AX,10    ;length of array is 16 words (10 hexadecimal)
PUSH  AX
MOV   AX,5     ;value to be added
PUSH  AX
CALL  SAMPLE

;SAMPLE procedure
PUSH  BP ;Save BP for protection
MOV   BP,SP ;Point BP at top of stack
MOV   AX,[BP + 4] ;Get value to be added
MOV   CX,[BP + 6] ;Get length of array
MOV   SI,[BP + 8] ;Get offset of array
JCXZ  STOP ;Skip loop if CX = 0
AGAIN: ADD [SI],AX ;Otherwise add value in AX to array
        ;whose offset is in SI
        ADD SI,2 ;Have SI point to next word
        LOOP AGAIN ;Do this CX times
STOP:  POP BP ;Restore BP
        RET 6 ;Return and add 6 to SP to point at
        ;old top of stack
    
```

Figure 3: Using the BP register to access parameters.

To access the parameters, you use the BP register plus a displacement. As shown in figure 3, the return address is at BP + 2 and the parameters are at BP + 4, BP + 6, and BP + 8. This satisfies the first requirement to access parameters on the stack. Another benefit of using the stack is that you can subtract a value from the SP register after having BP point to it. Then, if you use a negative displacement with BP, you can access this area as a workspace for your procedure's local variables.

The procedure then moves these parameters into the proper registers. Next, you check the CX register for zero so that you don't do the loop 65,536 times. In the loop, you add the contents of the location pointed to by SI with the value in AX, and place

the result back in memory. Then SI is made to point to the next word by adding 2 to it. You repeat this process CX number of times.

Now, you have to clean up the stack. If you simply pop the BP register and return, the SP register would be pointing at the first parameter, which is not where it is supposed to point. If you just did this, you would have to make it part of the calling program to pop the parameters off the stack. Because a procedure can be called several times, this would involve a large amount of overhead. To clean up the stack, the RET instruction can have a value that is added to the SP register after the return address is placed back in the IP register. In the sample program, the value added to the SP register is

Will This Happen to You?

NOT IF YOU BUY YOUR PRINTER FROM...

THE PRINTER STORE

After reading this issue of *BYTE Magazine*, you are now fully aware of the many outstanding printers on the market today. But what you might not be aware of is that the printer you like best, might not be compatible with your computer and software. (The picture above is good example of printer incompatibility). At the **Printer Store**, we specialize in printers, so our experienced professional staff can help you choose the right printer for your personal and business needs. If you want the **Best Value, Low Price, Product Availability, and Support**, call The Printer Store and ask us about:

- FULL FACTORY AUTHORIZED SERVICE
- FREE TECHNICAL CONSULTATION
- FULL AFTER SALE SUPPORT

DOT MATRIX PRINTERS

EPSON SERIES	
FX 80	\$ CALL
FX 100	\$ CALL
OKIDATA SERIES	
82 A	\$ CALL
83A	\$ CALL
92A	\$ CALL
93A	\$ CALL
84 (parallel)	\$ CALL
C. ITOH SERIES	
8510 Prowriter	\$ 395
Prowriter II	\$ CALL
New! Banana	\$ 239
IDS SERIES	
Microprism 480	\$ CALL
Prism 80	\$ CALL
Prism 132	\$ CALL
GEMINI SERIES	
Gemini 10X	\$ CALL
Gemini 15	\$ CALL
NEC 8023	\$ 419
Toshiba P 1350	\$1750

LETTER QUALITY PRINTERS

BROTHER SERIES	
HR-1 (parallel)	\$ CALL
HR-1 (serial)	\$ CALL
HR-15	\$ CALL
COMREX SERIES	
CR-1 (parallel)	\$ 795
CR-1 (serial)	\$ 865
CR-2	\$ CALL
C. ITOH SERIES	
F-10 40 CPS	\$ CALL
F-10 55 CPS	\$ CALL
Daisywriter 16K. 48K	\$ CALL
NEC SERIES	
3510	\$ CALL
3530	\$ CALL
3550	\$ CALL
7710	\$2425
7720	\$2900
7730	\$2400
NEC Accessories	\$ CALL

C. ITOH 8510 Prowriter

- 120 CPS - 1.3K Buffer - 144x60 dots 1 inch Nx9 dot matrix - Proportional Spacing - 8 Character sizes - 5 unique alphabets - Greek character set - Graphic symbols - bi-directional, logic-seeking - Adjustable tractors - Single-sheet friction feed - Vertical & horizontal tabbing.
- C. ITOH 8510 Prowriter List \$795 **\$ 395**

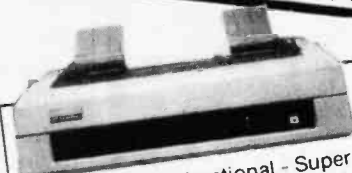

BROTHER HR-1

- 16 CPS - Bi-directional - Super and Subscript
 - IBM Selectric type ribbon - Prints up to 6 copies
 - Ideal for word processing
- Brother HR-1 Parallel List 1100 **\$ Call**
 Serial List 1200 **\$ Call**

INTERFACE EQUIPMENT

Apple Dumping	\$145
Grappler Plus	\$ CALL
Complete stock of Epson Accessories	\$ CALL
Custom Printer Cables for Apple, Atari, IBM, TRS-80 (all models)	\$ CALL
Printer stands: large	\$95
Printer stands: small	\$25
Printer ribbons	\$ CALL
Printer Sound Enclosure	\$CALL
Vic 20/Comm. 64 Interface ..	\$CALL

We carry a full line of Cables and Accessories
 Call (213) 470-1888 and ask us about...

PHONE REBATE
 THE **Printer**

We are so confident of our LOW PRICES and SUPPORT that we are going to ask you to make the initial investment by calling us. In return, when you buy your printer from us, we will rebate the cost of your call and deduct it from your invoice.

HOW TO ORDER: Our phone lines are open from 8 a.m. to 6 p.m. PST, Monday-Friday. We accept VISA, MASTERCARD (at no extra charge), personal checks take two weeks to clear. COD's accepted. Same-day shipment on orders placed before 1 p.m. Manufacturer's warranty applicable on all equipment. Prices subject to change.

- 1) LOW PRICES
- 2) FREE INTERFACING BOOKLET
- 3) FREE TECHNICAL SUPPORT
- 4) FULL SERVICE OPTION

STORE - 2357 Westwood Blvd., West Los Angeles, CA 90064

Circle 321 on Inquiry card.
 • The Printer Store. 1983

The MMSFORTH System. Compare.

- The speed, compactness and extensibility of the MMSFORTH total software environment, optimized for the popular IBM PC and TRS-80 Models 1, 3 and 4.
- An integrated system of sophisticated application programs: word processing, database management, communications, general ledger and more, all with powerful capabilities, surprising speed and ease of use.
- With source code, for custom modifications by you or MMS.
- The famous MMS support, including detailed manuals and examples, telephone tips, additional programs and inexpensive program updates, User Groups worldwide, the MMSFORTH Newsletter, Forth-related books, workshops and professional consulting.

mmsFORTH

A World of Difference!

- Personal licensing for TRS-80: \$129.95 for MMSFORTH, or "3+4TH" User System with FORTHWRITE, DATAHANDLER and FORTHCOM for \$399.95.
- Personal licensing for IBM PC: \$249.95 for MMSFORTH, or enhanced "3+4TH" User System with FORTHWRITE, DATAHANDLER-PLUS and FORTHCOM for \$549.95.
- Corporate Site License Extensions from \$1,000.

If you recognize the difference and want to profit from it, ask us or your dealer about the world of MMSFORTH.

MILLER MICROCOMPUTER SERVICES
61 Lake Shore Road, Natick, MA 01760
(617) 653-6136

Circle 276 on Inquiry card.

6, which is where the old top of stack was before the parameters were pushed on the stack by the calling program.

Interrupts

The 8086 has several sources for interrupts. An interrupt can come from external devices, software instructions, or within the 8086 itself. The external sources for interrupts come from two pins called INTR (interrupt request) and NMI (nonmaskable interrupt). The INTR pin is maskable by the IE (interrupt enable) flag in the 8086 flag register. If the IE flag is set, INTR can interrupt the 8086; if the IE flag is cleared, then INTR can't interrupt. NMI cannot be masked and is used mostly to report catastrophic events such as memory-parity errors or an imminent power failure.

As listed in table 1, the software interrupts are INT (interrupt), followed by the interrupt type and INTO (interrupt on overflow). The interrupts from the 8086 itself are divide error and single-step. Divide error is caused by a division having a quotient larger than the destination register, such as division by zero or dividing a large number by 1. Single-stepping is actually an interrupt after every instruction that is caused by the TF (Trap flag) in the flag register being set.

When you receive one of these interrupts, certain events occur. If it is an external interrupt, the current instruction has to finish execution (except if it is a MOV or a POP to a segment register, then it is the instruction following the current instruction). All the interrupt types then push the contents of the flag register on the stack. After this is done, the 8086 clears the IF and TF flags. This is to prevent any INTR inputs from interrupting the processor and to prevent single-stepping through the interrupt routine. Because the flags are saved, whatever they were prior to the interrupt will be restored after the routine is finished. Next, the 8086 pushes the contents of the CS and IP registers on the stack to save the return address in the same way a far CALL does. Finally, CS and IP are loaded from an interrupt-pointer

table, depending on the type of interrupt. The interrupt-pointer table is a reserved area of memory that occupies the first 1K bytes of memory space, as shown in figure 4.

Notice that certain interrupts have reserved pointers for them and can generate those types automatically when they occur. Divide error is type 0, single-step is type 1, nonmaskable interrupt is type 2, breakpoint is type 3, and overflow is type 4. In addition, types 5 through 31 are reserved by Intel for future use and should not be used at this time. The others are available for use by the INTR or INT instructions. For INTR, an external device supplies the type, and the INT instruction supplies the type in the instruction. The 8086 takes the type of interrupt, multiplies it by 4 to get to the correct table entry, and then loads it into the CS and IP registers. These table entries must be filled by you with the starting segment and offset of your particular interrupt routine. In other words, if you plan to include any divide instructions in your programs and you don't check the operands, you should fill the pointers at addresses 0 through 3 with the CS and IP values of a routine to handle a divide error.

The interrupt routine should save any register used by it because you don't know when the interrupt occurred for an external interrupt, and you wouldn't want to destroy anything that you might have in these registers. An IRET instruction should reside at the end of the interrupt. This instruction performs almost the same operation as a far RET instruction, but it also pops the flags back.

The INT instruction can check out interrupt-service routines by having the INT instruction followed by the type number of the one to be checked or used. For example, the divide-error routine might be the same as a routine needed in your program. The INT instruction can also be used for calls to another program to service particular devices. Because the code can be located anywhere in memory, but the interrupt-pointer table is at a fixed location, this makes it convenient to use for this purpose.

TEST-FLY A \$20 MILLION JET ON AN APPLE? YES. WITH MICROSPEED.

At the Bethesda Naval Research Center, they've discovered the power of MicroSPEED. The Navy's engineers use this remarkable hardware/software combination to "fly" an advanced fighter aircraft in *real time*—even making vertical landings on a simulated carrier deck. A "crash" is merely another learning experience, and an opportunity to modify the research aircraft—inside the Apple—to improve tomorrow's combat planes.

Surprised that such a sophisticated task is possible on the Apple? So were the Navy's officials, and many others who have discovered...

THE MICROSPEED DIFFERENCE This extraordinary Language System exploits the real potential of the microcomputer for the first time. The difference between MicroSPEED and other programming languages is that with MicroSPEED, there is virtually *no limit* to what you can achieve. It may well be the ultimate language for the Apple II and III (and soon the IBM Personal Computer). MicroSPEED literally combines the performance of a *minicomputer* with an exhaustive set of user-friendly capabilities: hard-

ware math processing, fast hi-res graphics and text, turtle graphics, print formatting, two text editors, unlimited data types, and incredible FORTH extensibility—all at speeds up to 100 times faster than Basic.

USER-FRIENDLY, EASY-TO-LEARN Starting with simple commands that are comfortable even for non-programmers, MicroSPEED extends and builds, allowing you to create your own tailored application languages. The capability of your computer will grow exponentially, as you work in an active partnership with the machine, exploring and developing new problem-solving facilities—creating, correcting, refining your increasingly powerful system.

DEMANDING JOBS AT LOW COST Developed by a team of standout computer professionals, MicroSPEED has been put to the test in fields as diverse as medicine, the stock market, oceanography, and the arts. In even the most challenging applications, MicroSPEED users have been unanimous in their praise of the System and manual. Typical comments are:

"Very high marks,"

Thomas Tosch Phd., Tosch Information Management.

"The more I use MicroSPEED, the more I love it,"

James L. Hockenhull, University of Washington.

"Great!...A joy to use,"

Henry Harris, Mission Designer, Cal Tech's Jet Propulsion Lab.

"If you plan to use the Apple or IBM Personal Computer for any demanding task, then we built MicroSPEED for you,"

Sam Cottrell, President of Applied Analytics.

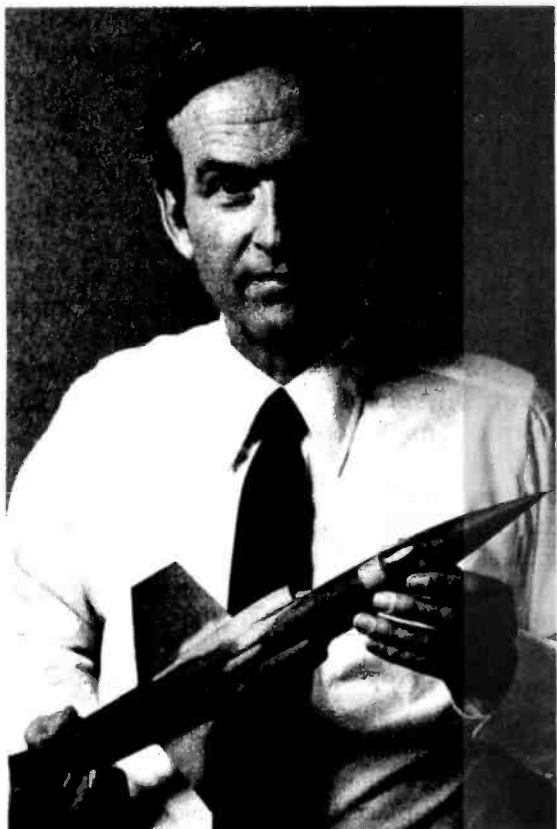

MicroSPEED requires the Apple or IBM Personal Computer with single disk. MicroSPEED II includes 2 MHz math processor. MicroSPEED II+ includes 4 MHz math processor.

Applied Analytics Incorporated

8910 Brookridge Drive

Upper Marlboro, Maryland 20772 (301) 627-6650

I'm interested! My computer is: _____

Please send me:

_____ MicroSPEED II, \$495.00 _____ 160 Page Manual, \$15.00

_____ MicroSPEED II+, \$645.00 _____ Detailed Information

Name: _____

Company: _____

Address: _____

City: _____ State: _____ Zip: _____ Phone No. () _____

Use this coupon to order, or for more information.

MicroSPEED 
APPLE IS A TRADEMARK OF APPLE COMPUTER INC.

MICROXPRESS

DISK DRIVES FOR

IBM · apple · TRS-80 **ZENITH** / HEATH®

AND OTHER PERSONAL/MICROCOMPUTERS

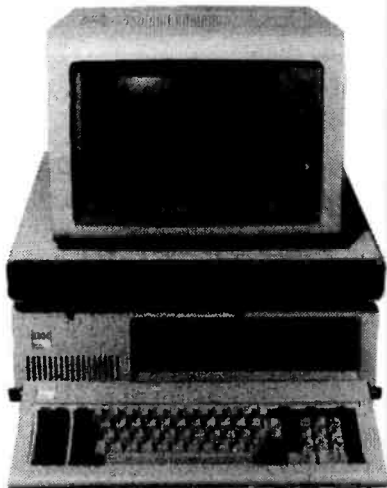

5-1/4" FULL HEIGHT INTERNAL MOUNTING FLEXIBLE DISK DRIVES FOR IBM PC & XT, **ZENITH**/HEATH® AND OTHER SMALL COMPUTERS:

GD CONTROL DATA CORPORATION CDC 8400 DOUBLE-SIDED, 48TPI, 320/360KB	245
Tandon TM100-2 DOUBLE-SIDED, 48TPI, 320KB	235
TM101-4 DOUBLE-SIDED, 96TPI, 640KB	295

5-1/4" 1/2 HEIGHT INTERNAL MOUNTING FLEXIBLE DISK DRIVES (INCLUDES STRAP KITS TO MOUNT IN FULL HEIGHT FOOTPRINT) & MS STEP RATE

Tandon TMS0-2 DOUBLE-SIDED, 48TPI	(2) DRIVES FOR	375
QUIMTRAK 142 DOUBLE-SIDED, 48TPI	(2) DRIVES FOR	445
TEAC FD 55-B DOUBLE-SIDED, 48TPI	(2) DRIVES FOR	575
TEAC FD 55-F DOUBLE-SIDED, 96TPI	(2) DRIVES FOR	750
IBM 4 DRIVE ADAPTOR CABLE		Call

8" THINLINE FLEXIBLE DISK SUBSYSTEM

(SHOWN ABOVE) FULLY ASSEMBLED & TESTED WITH COMPLETE DOCUMENTATION	
I-8480 DUAL DRIVE, DOUBLE-SIDED, 2.4MB	\$1,495
I-8481 SINGLE DRIVE, DOUBLE-SIDED, 1.2MB; INCL. FILLER PANEL - SECOND DRIVE CAN BE ADDED LATER	995
*8" FLEXIBLE DISK CONTROLLERS FOR IBM PC & apple NO CONTROLLER NEEDED FOR ZENITH /HEATH® 2-100	Call

apple DISK DRIVES

DATA DRIVE 5-1/4" FLEXIBLE DISK EXTERNAL SUBSYSTEM BY TAVA CORP.	275
--	-----

IBM PC DOS SOFTWARE UTILITIES FROM TALL TREE SYSTEMS

J FORMAT ENABLES USE OF 5-1/4" O.S. 96TPI & 8" FLEXIBLE DISK DRIVES PLUS OTHER FEATURES FOR IBM PC DOS 1.10 VERSION 1.70	50
J FORMAT-2 SAME AS J FORMAT ABOVE FOR IBM PC DOS 2.0	35
WINDRIVE ENABLES USE OF WINCHESTER SUBSYSTEMS FOR IBM PC DOS 2.0	35
JETDRIVE ENABLES IMPLEMENTATION OF ELECTRONIC DISK FOR IBM PC DOS 2.0	35
J UTILITIES INCLUDES J FORMAT-2, WINDRIVE & JETDRIVE	85

IBM PC 5-1/4" & 8" DISK CONTROLLERS, MULTIFUNCTION & RAM CARDS

MAYNARD ELECTRONICS FDC 5-1/4" FLOPPY DRIVE CONTROLLER	175
FDC/PS 8"	195
SANOSTAR™ SERIES MULTIFUNCTION & MEMORY MODULES	Call
64K RAM EXPANSION	65

AST RESEARCH 100 CLOCK CALENDAR W/BATTERY AND SERIAL PORT	129
ORCHID PC NET	635
HERCULES GRAPHICS CARD	395

GD CONTROL DATA CORPORATION DISKETTES

1242-00	5-1/4" SINGLE-SIDED, SINGLE/DOUBLE DENSITY, WRITE PROTECT NOTCH & HUB RING (Box of 10) Special 19.95	Guaranteed Error Free
1244-00	5-1/4" DOUBLE-SIDED, SINGLE/DOUBLE DENSITY, WPN & HUB RING (Box of 10) Special 29.95	
-	8" SINGLE OR DOUBLE-SIDED, SINGLE/DOUBLE DENSITY, WPN & HUB RING, VARIOUS FORMATS	Call

MONITORS & GRAPHICS CARDS

NEC JB 1201M JC 1212 JC 1203D	12" HI RES GREEN 12" HI RES COLOR IBM PC 12" HI RES COLOR	180 323 715
AMDEK VIDEO300 COLOR I COLOR II	HI RES GREEN 13" HI RES GREEN HI RES RGB	149 340 485
USI PI2 PI3 PI4	HI RES 12" GREEN AMBER 12" MONITOR AMBER 9" MONITOR	163 163 145
1400C -	COLOR 12" MONITOR COLOR GRAPHICS CARD	325 349
PGS HX12	12" COLOR MONITOR	565
PLANTRONICS	COLOR GRAPHICS CARD	405
QUADRAM CH8400	QUADCHROME MONITOR	549

MICROXPRESS

(714) 632-8512

305 S. State College Blvd.
Suite 135
Anaheim, CA 92806



00400	TYPE 255	C S BASE ADDRESS
003FC	(AVAILABLE)	
00084	TYPE 33 (AVAILABLE)	IP OFFSET
00080	TYPE 32 (AVAILABLE)	
0007C	TYPE 31 (RESERVED)	
00014	TYPE 5 (RESERVED)	
00010	TYPE 4 (OVERFLOW)	
0000C	TYPE 3 (BREAKPOINT)	
00008	TYPE 2 NONMASKABLE	
00004	TYPE 1 SINGLE-STEP	
00000	TYPE 0 DIVIDE ERROR	

16 BITS

Figure 4: The interrupt-pointer table reserves the first 1K bytes of memory space. Each type of interrupt contains two words, which point to the segment and the offset of the interrupt routine that handles that type.

The INTO instruction is a conditional interrupt on the Overflow flag. This instruction generates a type 4 interrupt if the Overflow flag is set. Otherwise, control is passed to the next instruction. You could use this instruction after an arithmetic or logic instruction as a conditional CALL on the Overflow flag.

If you're like me, your programs often have bugs in them, and you would like to debug them easily. Two operations are provided to make this job easier. One is the INT 3 instruction, a special 1-byte form of the INT instruction. You can substitute this instruction for the op code of the instruction that you want to set a breakpoint for. Your interrupt routine would then interrogate registers, by pushing them on the stack, or certain memory locations. An INT 3 instruction could also be a way of inserting new instructions in a program to test new ideas without reassembling or recompiling.

The other operation provided to aid debugging involves setting the Trap flag in the flag register. When the Trap flag is set, the 8086 does an automatic type 1 interrupt after each instruction, except on a MOV or POP to a segment register. The procedure you write can then look at certain things, display them, or do whatever you want. There is no instruction to set the Trap flag; how often would you use it in normal programming? A simple program to set the Trap flag might look like this:

```
PUSHF
POP AX ;Bring the flags
;into AX
OR AX,0100 ;Set bit 8 of the
;flag register
PUSH AX
POP PF ;Place it back in
;the flag register
```

To clear the Trap flag, you could replace the OR instruction with an

LOOKING FOR A MULTI-USER, HARD DISK COMPUTER SYSTEM YOUR CUSTOMERS CAN AFFORD?

It's the Morrow Decision I.™

Starting at \$5,495 retail. That's the basic Morrow 10MB system with 256K of RAM. Including a 14-slot S-100 (IEEE-696) motherboard, a 400KB floppy, one parallel and three serial ports.

A bundle of software. Beginning with our multi-user Micronix™ operating system, with both UNIX™ and CP/M® 2.2 compatibility. The Decision I also includes WordStar® word processing, the Correct-It™ spelling checker, Microsoft® BASIC 80, the LogiCalc™ electronic spreadsheet and Personal PEARL™, a relational data base manager.

Economical expandability. For customers with growth on their minds, the Decision I offers very affordable possibilities. Another \$2,000 buys 6 MB more memory, 256K more RAM and the ability to add three more users.

A few good dealers. That's who we're looking for. People who know how to sell and service multi-user, multi-tasking micro-computer systems. If you're one of those dealers, or a qualified systems integrator, call us. We'd like to introduce you to Morrow's complete line of S-100, multi-user micro-computers, disks and peripherals. Systems your customers can afford.

MORROW

Marketing Resources, P.O. Box 60055
Sunnyvale, CA 94088, (408) 980-7279
(800) 538-8157 EXT. 960
(800) 672-3470 EXT. 960 In California



Decision I, Correct-It, and Micronix are trademarks of Morrow, Inc.
CP/M is a registered trademark of Digital Research, Inc.
Microsoft is a registered trademark of Microsoft Corporation.
WordStar is a registered trademark of Micro Pro, Inc.
Personal PEARL is a trademark of Relational Systems, Inc.
UNIX is a trademark of Bell Laboratories, Inc.
LogiCalc is a trademark of Software Products, Int'l.

Mnemonic	Description of Operation
MOVSB/MOVS	Move byte or word string
CMPSB/CMPS	Compare byte or word string
SCASB/SCAS	Scan byte or word string
LODSB/LODS	Load byte or word string
STOSB/STOS	Store byte or word string
REP	Repeat
REPE/REPZ	Repeat while equal/repeat while zero
REPNE/REPNZ	Repeat while not equal/repeat while not zero

Table 3: The string instructions let you work with blocks of data using 1-byte instructions.

Register or Flag	How Contents Are Used
SI	Index (offset) for source string
DI	Index (offset) for destination string
ES	Segment of destination string
CX	Repetition counter
AL/AX	Scan value
	Destination for LODS
	Source for STOS
DF	0 = auto-increment SI,DI 1 = auto-decrement SI,DI
ZF	Scan/compare terminator

Table 4: The string instructions use dedicated registers to generate fewer instructions, and they are shorter (1 byte) in length.

String Instructions

At times, you need to manipulate large blocks of data in memory, such as moving them from one location to another, searching for a particular value, etc. You could accomplish this with the instructions shown in figure 5's first program. In program 1, you load the SI register with the offset of the block you wish to move, the DI register with the offset of where you wish to move it to, and the CX register with the number of bytes you wish to move. The actual move requires loading the word using SI and saving the word using DI. Then you move the pointers to the next word and loop back and repeat it. This accomplishes the tasks you set out to do but requires several instructions and extra time to perform them.

Instead, string instructions, as shown in table 3, could be used to solve this problem. They can do byte or word operations and are actually short (1-byte) instructions. They use dedicated registers, as shown in table

You can
now order
article
reprints
from this
publication

University Microfilms International, in cooperation with publishers of this journal, offers a highly convenient Article Reprint Service. Single articles or complete issues can now be obtained in their original size (up to 8½ x 11 inches). For more information please complete and mail the coupon below.

ARTICLE REPRINT SERVICE

University Microfilms International

- YES! I would like to know more about the Article Reprint Service. Please send me full details on how I can order.
 Please include catalogue of available titles.

Name _____ Title _____

Institution/Company _____

Department _____

Address _____

City _____ State _____ Zip _____

Mail to: University Microfilms International
 Article Reprint Service
 300 North Zeeb Road
 Ann Arbor, Michigan 48106

It's True — We Did It!

We have met or have beaten most advertised prices.

Don't be foolish. Buy Direct!

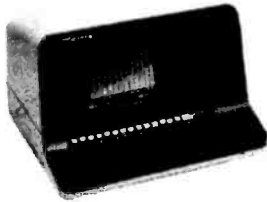

NORTHSTAR

ADVANTAGE

- 64K, Z80A Operating System
- 2 Quad Capacity Floppy Drives
- Business Graphics Software
- 12" Green Phosphorus Screen
- Bit Mapped Graphics
- 6 I/O Business Slots

HORIZON

- Multi User System
 - Z80A Operating System
 - S-100 Bus
 - 5Mb-18Mb Hard Disc Available
- Super Super Super **\$2,495.00**

Super Super Super **\$1,995.00**



IDS

- Proportional Spacing
 - 8 Character Styles
 - 200 CPS Bi Directional
 - Color Optional
 - Sheet Feed
 - Graphics
- Prism 80 W/Sprint **\$899.00**
 Prism 80 Loaded W/Color **\$1,239.00**
 Prism 132 W/Sprint **\$1,039.00**
 Prism 132 Loaded W/Color **\$1,395.00**
 Colortext for IDS **\$104.00**



GTC

- VT 100 Look Allke Keyboard
- Programmable Function Keys
- Printer Port Split Screen Capability

GTC SW10 \$659.00
 GTC 100A **\$689.00**
 GTC SW80 **\$795.00**



ALTOS
ZENITH
TELEVIDEO
SANYO

FRANKLIN
HAYES
NOVATION
UDS

OMNITEC
VENTEL
AMDEK
BMC

TAXAN
DIABLO
NEC
EPSON

OKIDATA
OSBORNE
COMREX
DAISYWRITER

GTC
ADDS
DEC
MANY OTHERS

For Price Quotes and Ordering Call:

1-800-328-8905

For Technical Information and Arizona Orders Call:

602-949-8218

411 South Madison
Tempe, Arizona 85282
(Mail Order Only)

LIBERTY
COMPUTER SALES



Everything in computer related products:

- Computers
- Modems
- Printers
- Software
- Monitors
- Terminals
- Accessories
- Paper
- Ribbons
- Diskettes
- Office Furniture

Prices listed reflect a cash discount and are subject to change without notice. We welcome Certified and Cashiers Checks, Bank Wires and Money Orders. Allow 2 to 3 weeks for personal checks to clear. Product is subject to availability. Equipment is in factory sealed boxes with manufacturer's warranty. There will be a restocking charge for returned merchandise. Call first for an RMA number. Software not warranted for suitability. No return of Software which has been opened. Add 2% for shipping charges (minimum \$2.50). Z80A is a registered trademark of Zilog, Inc.

Circle 237 on inquiry card.

Sundex

FOR PAYING BILLS...
This could be the last check
you write



Because it lets you try Sundex's Personal Payables™ program, designed to take over tedious bill paying chores.

Personal Payables™

- writes checks—standard or continuous form
- alerts you to payments coming due
- stores amounts payable for regular payments
- keeps continuous, accurate balance
- handles up to 10 checking accounts

And We've Taken the Fear Out of Trying... our easy-English manual and on-screen instructions make it easy for anyone in the family to do it.

Start now to write off writing checks! To Try It—send **\$19.95** for full use of program (limited to writing 8 checks). When you're ready to buy it, call us toll free for the access code and we'll bill you for the balance (\$80.00). To Buy It **NOW**—send **\$99.95** and never write another check

- Yes, I want to take advantage of your TRIAL OFFER—\$19.95**
- I'm convinced, send me your Personal Payables™ Program—\$99.95**

Specify: IBM 128K IBM 64K
 COMPAQ Osborne
 Apple II TI Professional
 Apple Iie

Payment: Check VISA MasterCard
 Colo. residents add 3% sales tax

Card # _____ Exp. Date _____

Signature _____

Name _____

Address _____

City _____ State _____ Zip _____

Mail to: Sundex Software Corp.

Dept 8V082

3000 Pearl St.

Boulder, CO 80301



Phone orders: 1-800-835-3243

In Colorado call: 1-303-440-3600

Program #1

```
;This program will move a block beginning at BLOCK1 to a block
;beginning at BLOCK2. The DS register is pointing at the
;segment that contains these blocks. Each block is 80 words
;long (50 hexadecimal)
```

```
LEA SI,BLOCK1 ;Get the blocks offsets in
LEA DI,BLOCK2 ;the index registers
MOV CX,0050 ;Number of words to move (80 decimal)
AGAIN: MOV AX,[SI] ;Bring in from BLOCK1
MOV [DI],AX ;Save this word to BLOCK2
ADD SI,2 ;Move pointers to next word
ADD DI,2
LOOP AGAIN ;Using CX as a counter to do 80 times
```

Program #2

```
;This program is the same as the first except the string
;instruction MOVSW is used and AX is not destroyed
```

```
PUSH DS ;Make ES point to the same segment
POP ES ;as DS to use as destination
LEA SI,BLOCK1
LEA DI,BLOCK2
MOV CX,0050
CLD ;Set up auto-increment of SI and DI
REP MOVSW ;Same as AGAIN loop except AX is
;not affected
```

Figure 5: Using the string instructions to move a block of data.

4. Registers DS and SI are the source pointers (DS can be overridden as the segment register to be CS, ES, or SS), and ES and DI are the destination pointers. The SI and/or DI registers are automatically incremented or decremented by 1 for a byte operation or by 2 for a word operation. The DF (Direction flag) in the flag register decides whether SI and/or DI are incremented or decremented. If DF is set, then you decrement or proceed to lower addresses; if DF is cleared, then you increment. The DF can be set by the STD (set direction) instruction and cleared by the CLD (clear direction) instruction.

String primitives perform single byte or word operations. Such primitives as MOVSB (move string byte) and MOVSW (move string word) transfer the contents of the location pointed to by SI to the location pointed to by DI with SI and DI adjusted. Primitives CMPSB (compare string byte) and CMPSW (compare string word) compare the contents of the location pointed to by SI with the contents of the location pointed to by DI with SI and DI adjusted, which affect the flags the same as a CMP instruction. Primitive SCASB (scan string byte) compares the contents of the AL register to the

contents of the location pointed to by DI; SCASW (scan string word) does the same with AX. Only the DI register is adjusted with this instruction. Primitive LODSB (load string byte) transfers the contents of the location pointed to by SI to the AL register; LODSW (load string word), to the AX with SI adjusted. Primitive STOSB (store string byte) transfers AL to the location pointed to by DI; STOSW (store string word) transfers AX with DI adjusted.

To do block operations, you can place a 1-byte prefix in front of a string primitive called a REP (repeat) prefix. You would use REP in front of the MOVSB, STOS, or LODSB primitives to repeat that operation the same as a LOOP instruction would. CX contains the number of MOVSB, STOS, or LODSB operations you want to do with a REP prefix. As shown in figure 5, MOVSW with a REP prefix accomplishes in program 2 the same task done in program 1. Notice that the ES register is initialized and the Direction flag is cleared for auto increment. Using REP before a STOS instruction lets you initialize a block of memory with a certain value, such as a zero to clear a block of memory. However, REP would probably not be used before a LODSB

VR DATA CORPORATION ANNOUNCES: THE PRICE WAR IS OVER!!

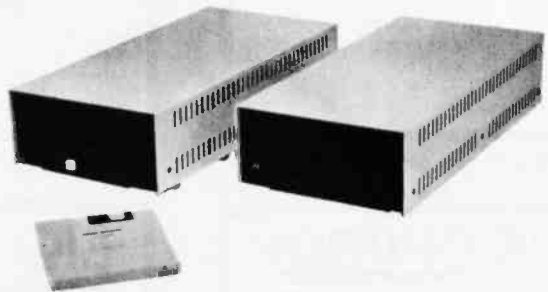
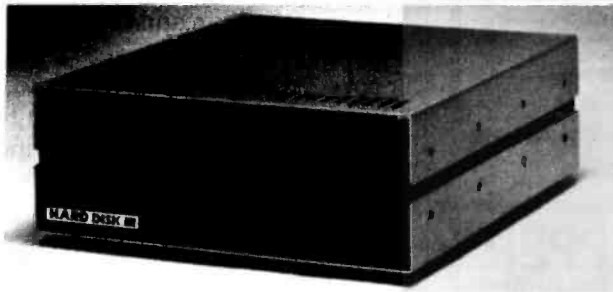

**HARD DISK III*
5 MEG
WINCHESTER** **995.**

5+5 Meg System	1590.00	10 Meg System	1249.00
15 Meg System	1449.00	10+10 Meg System	1999.00
15+15 Meg System	2299.00		

*Hard Disk III includes up to 2 full height Winchester disk drives, heavy duty enclosure, disk controller, field proven power supply, I/O adaptor, and applicable cabling.

*Hard Disk III is available directly from the factory only.

HARD DISK III & HD-505 ADAPTOR MODULES:

IBM-XT*	IBM-PC	150.
APPLE II*	APPLE IIe*	
XEROX 820*	XEROX 820-II*	
FRANKLIN*	LNW-80	
TRS-80 MOD I	LNW-II	
TRS-80 MOD III	TRS-80 MOD 4	

OTHERS TO BE ANNOUNCED

*AVAILABLE 3RD QUARTER 1983

NEW
HD-505 WINCHESTER
Compact, High Density, Low Profile,
Low Power, Sub-Mini Disk System

**SAVE \$90 on 5+5 Meg
(Fixed/Removable) Package**

Package includes:
 HD-505F (Master) Fixed 5 meg **1395.00**
 HD-505R (Slave) Removable 5 meg **1095.00**
 Adaptor Module **150.00**
 Disk Cartridge for HD-505R **FREE!!!**

TOTAL 2490.00

The NEW HD-505 Winchester Systems are available through quality Computer Stores everywhere. If yours doesn't have the HD-505 from VR DATA, tell them to get it.

MASTER unit includes: enclosure, switching power supply, disk drive, controller, host adaptor, applicable cabling.
SLAVE unit includes: enclosure, switching power supply, disk drive, applicable cabling.

Call Toll Free • 800-345-8102



Published prices reflect cash discount. All prices are subject to change without notice. TRS-80 and TRSDOS are trademarks of Tandy Corp. Disk III and HD-505 are trademarks of VR DATA CORP.
 8:30 am-7pm EST Mon-Fri., Sat 10am-3pm
 CABLE "VRDATA" TELEX 845-124

All VR DATA products are tested, burned-in, and re-tested. We're so proud of our quality control that we offer an optional unconditional extended warranty covering full costs of parts and labor on all VR DATA products.

VR data

(215) 461-5300
 777 Henderson Blvd.,
 Folcroft, PA 19032

VR DATA—WEST
 Watonga, OK
 1-405-623-8664

SOURCE SOFTWARE

Professional-quality, CP/M compatible Z80 assembler accepts standard Zilog mnemonics as well as 19 pseudo-ops, prints a sorted symbol table, and can read from multiple input files. Modular structure allows easy revision as a cross-assembler.

Complete source listing with detailed tutorial on theory of assemblers is contained in a 200-page manual. Professional techniques fully explained include Radix 40, binary search, expression processing by recursive descent, etc.

Source code also available on a standard format 8" SSSD disk.

Manual with listing \$25
Manual and 8" disk \$50

(foreign orders add \$3 surface, \$10 airmail)

King Software

PO Box 208
Red Bank, N.J. 07701
(201) 530-7245

NJ residents please add 6% sales tax

Circle 232 on inquiry card.

FINAL OFFER BEFORE PRICE INCREASE!

An Accounts Payable System for the small business with an Apple II* Computer, at the unbelievable low price of

\$50

Special Features Include:
•One time input of repetitive pymts.
•Multiple General Ledger distributions per Invoice, both debits & credits
•Checking balance maintenance, allows manual and/or void chks
•High speed machine language programs & random access files
•Payroll & expense check pymts.
•Cash requirements projection
•Optional remote work station input & processing at no extra cost

This program will be in stores in a few months at a much higher price.

ACT NOW & SAVE!!

Offer expires Sept. 30, 1983

We offer a 15 day money back trial period for you to review our documentation & decide to keep or return the sealed disk & the documents. Send check to:

ACCOUNTS PAYABLE RESEARCH & DEVELOPMENT CO.
8306 Wilshire Blvd., Suite 50
Beverly Hills, Ca. 90211
(213) 655-0765 or (213) 553-0371

Include \$2.00 for Shipping & Handling. Allow 4 weeks for delivery. Calif. residents, add sales tax for your county.

The system requires an Apple II* 48K computer with Applesoft** in ROM, 1 disk drive (DOS 3.3) & a printer.
*Trademarks or copyrighted programs of Apple Computer Co., Inc.

Circle 6 on inquiry card.

THE CHURCH Information Management System



ADAM II™

MODULES

- 1 Membership Module
- 2 Stewardship Module
- 3 Communications and Cataloging Module
- 4 Spiritual Growth Module
- 5 Outreach Module
- 6 Church Discovery Module

Demo Packages available for Modules 1, 2, 3

Your Software Guardian™

written in...
DBASE II™**
8 and 16 BIT, CP/M compatible

Digital Research Inc.
* Ashton Tate

DEALER INQUIRIES WELCOME

OMEGA User Lovin'™
INFORMATION SYSTEMS Software

PO Box 450125
Atlanta, Georgia 30345
(404) 329-0091

Your Software Guardian, ADAM II & User Lovin' Software are trademarks of Omega Information Systems

Circle 293 on inquiry card.

BIG STEPPER Stepping-Motor Driver Box

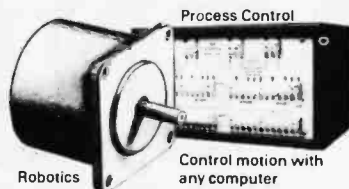

HOOKUP AND GO!

Provides required motor power

Drives 4 motors at up to 5 amps per winding while sensing 8 limit switch inputs

PARALLEL "BIG STEPPER": \$450
SERIAL "SMART STEPPER" (RS232): \$850
STEPPING-MOTOR TIPS COOKBOOK: \$5

Centre Computer Consultants
P.O. Box 739 State College, PA 16801
(814) 237-4535

Circle 66 on inquiry card.

instruction.

For the CMPS and SCAS instructions, you have the conditional REP prefixes of REPZ/REPE for repeat while zero/repeat while equal and REPNZ/REPNE for the opposite condition. These are similar to the conditional LOOP instructions. For example, if you use the REPNE in front of the SCASB instruction, you will stop repeating if CX equals zero or if a match is found between the AL register and the location pointed to by the DI register. You could use the REPNE instruction and check the CX register for zero. If it is zero and ZF is not set, then no match is found. If CX is not zero or ZF is set, then the DI register is pointing to the location following or before the matching character, because it is auto-decremented/incremented on each repetition by the SCAS instruction. A program demonstrating this setup is shown in figure 6.

With a repeat prefix, CX is checked for zero before the operation, which is different from the LOOP instruction. This means that you don't have to precede the repeated string operation with a JCXZ to prevent doing it 65,536 times. Another interesting point is that an interrupt can be recognized during a repeated string operation at each repetition. These are the only instructions that allow interrupts during execution because using a REP might tie up the 8086 for a long period of time.

Primitives also permit you to build your own string operations. For example, you could translate an entire block of memory from one code to another after the registers are set up correctly:

```
AGAIN: LODSB
      XLAT
      STOSB
      LOOP AGAIN
```

Processor-Control Instructions

Processor-control instructions let programs control various 8086 functions, as shown in table 5. The STC (set carry), CLC (clear carry), and CMC (complement carry) instructions affect the Carry flag. Instructions STD and CLD are explained in

NOW

16-BIT MICROPROCESSOR
SEMINARS ON CASSETTE

\$129⁹⁵ PER SET

This unique cassette album is based on a 3-day seminar presentation condensing comparative information about the Z8000, 68000, and 8086 and includes a complete set of seminar material. Now, at your own pace you can assimilate the facts on each microprocessor that will enable you to tailor an intelligent decision to best fit your needs. Additional copies of handout material in attractive binders are available with cassette order for \$25/copy.

Send payment (MasterCard, Visa or check, no COD's please) to Daltech MicroSystems, P.O. Box 810672, Dallas, TX 75381, or phone 214/245-9006. Allow 4 to 6 weeks for delivery.

Circle 125 on inquiry card.

CROMEMCO OWNERS UPGRADE TO DOUBLE DENSITY

Hundreds of Cromemco owners have installed the FDCX4 Double Density Upgrade Board and doubled their disk storage. You can, too.

It's easy. The FDCX4 plugs right into your 4FDC board and turns it into a full-function double density disk controller.

Some features of the FDCX4 are:

- Analog PLL separator for reliability.
- Write Precompensation. Allows reliable double density operation with all drives (including PerSeC's).
- Works with CDOS, CROMIX, and double density CP/M.
- Reads, writes and formats 5" and 8" disks in single or double density. Sizes and densities may be mixed.
- Installs quickly and easily. Just unplug 2 chips from the 4FDC and plug the FDCX4 into the vacated sockets. No soldering is necessary if you use only 5" drives. If 8" drives are used, one solder joint completes the installation.
- Presently in use by Government agencies, Universities, Hospitals, large corporations and small businesses all over the world.
- No risk 15 day trial period.

Price is \$229.95 including shipping. We accept MC, VISA, and AMEX cards. C.O.D. is available only in the USA. California residents include 6% sales tax.

To order, or for more information, write or call:

JVB ELECTRONICS
1601 Fulton Avenue, Suite 1
Sacramento, CA 95825
Phone: (916) 483-0709

DEALER INQUIRIES INVITED.

CDOS & CROMIX are TMs of Cromemco. CP/M is a TM of Digital Research.

Circle 224 on inquiry card.

600 XL .. \$199.00
 800 XL... \$CALLS
 1200 XL. \$499.00
 1400 XL . \$CALLS
 1450 XL . \$CALLS
 1025 Printer \$399.00
 1020 Color Printer . \$245.00
 1027 Printer \$299.00

EASTERN HOUSE
 Monkey Wrench 2\$52.75
PARKER BROTHERS
 Tutankham R.....\$33.75
 Super Cobra R\$33.75
 Astro Chase R.....\$33.75
 Frogger R\$33.75
 QBert R\$33.75
 Popeye R\$33.75
 Risk R\$42.75
 Chess R\$42.75

APX
 Eastern Ft.41\$25.50
 DeRay Atari\$19.95
 Math-Tic-Tac\$15.95
 Pres of US.....\$15.95
 3R Math\$19.95
 Typo Attack\$24.95
 Family Budget\$19.95
 F. Cash Flow\$19.95

RANA
DISK DRIVE
 1000\$295.00

ALIEN GROUP
 Voice Box 2 . \$99.75
DON'T ASK
 Sam\$41.75
 Abuse\$15.95
 Teleatri\$27.95
 Poker Sam ..\$24.95



1010 Recorder.....\$75.00
 410 Recorder\$75.00
 810 Disk Drive.....\$399.00
 1050 Disk Drive\$335.00
 850 Interface.....\$CALLS

800 48K \$399.00*

* Plus \$100.00 Rebate back from ATARI

810 Disk\$399.00

Lycy Computer Marketing & Consultants

TO ORDER

TOLL FREE 800-233-8760

CALL US

In PA 1-717-327-1824

MODEMS

ANCHOR MARK I ..\$79.00
 ANCHOR MARK II..\$79.00
 HAYES SMART ...\$239.00
 HAYES MICRO II \$309.00
 Micro Bit
 MPP-1000.....\$159.00
 NOVIATION
 CAT\$144.00
 D-CAT\$155.00
 J-CAT\$115.00
 APPLE CAT II ..\$279.00
 212 APPLE CAT ..\$589.00



AT88 S1 . \$379.00
44S1\$499.00

MONITORS

Amdek Color I\$275.00
 Amdek 300 Green\$149.00
 Amdek 300 Amber\$149.00
 Gorilla Green\$99.00

RANA DISK DRIVES

Elite 1\$295.00
 Elite 2\$449.00
 Elite 3\$559.00
SSI
 Battle of Shilo\$26.75
 Tigers in the Snow.....\$26.75
 Cosmic Balance\$26.75
 Knights of the Desert..\$26.75
 Battle for Normandy ..\$26.75
 Germany 1985\$36.75
CONTINENTAL
 Home Accountant\$51.75
 Book of Apple Software . \$16.75



APPLE DUMPLING GX\$99.75
 APPLE DUMPLING 64...(16 Buffer)\$179.75
INFOCOM
 Zork I, II, or III.....\$26.75
 Deadline\$33.75

BLANK DISKETTES

ELEPHANT SS/SD.....\$18.25
 ELEPHANT SS/DD.....\$21.75
 KANGAROO SS/DD with
 storage case\$24.75
 MAXELL MD I\$29.75
 MAXELL MD II\$39.75
 DISK CASE (holds 10) \$4.95
 DISK CASE (holds 50) \$19.75
 ROM CASE (holds 10) \$19.75

VIC 64.....\$SAVE

1541 Disk Drive Call
 1525 Printer Call
 1530 Datasette\$64.00
 1110 8k Ram.....\$53.75
 1211 Super Expander . \$53.75
 1212 Programmers Ad. \$44.75
 1213 Vicmon.....\$44.75
 Vic 20 dust cover.....\$6.99
 Vic 64 dust cover.....\$6.99
HES 64
 Turtle Graphics R\$49.75
 Heswriter R\$38.75
 Gridrunner R\$29.75
 Attack of Mut Cam R...\$34.75
 Turtle Tutor R\$29.75
 Turtle Trainer R\$29.75
 Paint Brush R\$23.75
 Benji Space Rescue D. \$29.75
 Home Manager C/D ...\$39.75

CARDCO

Cardprinter / LQ1.....\$499.00
 Cardprint DM1\$109.00
 5 Slot Expansion 64\$54.00
 64 Write NOW.....\$39.00
 64 Mail NOW.....\$29.00
 20 Write NOW.....\$29.00
 64 Keypad\$29.00
 Universal Cass. Int.....\$29.75
 Printer Utility.....\$19.75
 6 Slot Expansion.....\$79.95
 3 Slot Expansion.....\$24.95
 Vic 20/64 Printer Int...\$59.95
SPINNAKER 64
 Kindercomp\$21.75
 Story Machine\$23.75
 Face Maker\$23.75
 Snooper Trooper.....\$29.75
 Delta Drawing\$34.75

commodore

HES VIC-20
 Torg C.....\$14.75
 HES Games I C\$14.75
 HES Games II C\$14.75
 VIC Fortit Rom\$42.75
 HES MON Rom\$28.75
 Turtle Graphics Rom ...\$28.75
 HES Writer Rom\$28.75
 Shamus Rom\$28.75
 Protector Rom\$31.75
 Robot Panic Rom\$28.75
BRODERBUND 64
 Serpentine R\$26.75
 Choplifter R\$32.75
 Seafox R\$26.75
PARKER 20
 Frogger (ROM)\$33.75
 QBert (ROM)\$33.75
 Tutankham (rom)\$33.75

SANYO

MBC 1000.....\$1549.00
 (with micropro software package)
 MBC 1250.....\$2195.00
 MBC4050\$2749.00
 EFD 160 Disk\$499.00
 5500 Letter Q. Printer..\$649.00

PRINTER
 RIBBONS
 AVAILABLE

PROWRITER 2P.....\$699.00
 GEMINI 15\$449.00
 PRINTMASTER....\$1589.00
 SMITH CORONA TP1...\$549.00
 CITOH 8600B.....\$1025.00
 STARWRITER.....\$1099.00
 OKIDATA 82 \$SAVE
 OKIDATA 83 LOWEST
 OKIDATA 84P..... PRICE
 OKIDATA 93 AVAILABLE
 TRACTOR.....\$49.75
 OKIDATA 92.....\$SAVE

SAVE on these PRINTERS

GORILLA GX-100\$199.00

EPSON \$CALL

GEMINI 10 \$299.00

PROWRITER..... \$365.00

NEC 8023 \$399.00



TO ORDER



POLICY

CALL TOLL FREE
800-233-8760

In PA 1-717-327-1824

or send order to
 Lycy Computer
 P.O. Box 5088
 Jersey Shore, PA 17740

In-stock items shipped within 24 hours of order. Personal checks require four weeks clearance before shipping. No deposit on C.O.D. orders. Free shipping on prepaid cash orders within the continental U.S. PA residents add sales tax. All products subject to availability and price change. Advertised prices show 4% discount offered for cash, add 4% for Master Card or Visa. DEALER INQUIRIES INVITED.

Data for Our Most Extensive Computer Salary Survey Has Been Compiled!



Call Today for Our New, FREE Mid-year Report.

It covers more positions and places!

Do you know how your salary compares with your peers? Whether computer professionals make more or less in other geographic areas. Or, now that recession is history, what economic resurgence will mean in terms of future compensation levels for computer people?

Our new, mid-year *Local Metropolitan Computer Salary Survey*—the most extensive one published to date—details salary differences in major metropolitan areas throughout the United States and Canada. It's chock-full of new statistics; some you'll find have changed substantially from past reports.

2,350 position and compensation categories.

The new Survey is based on an in-depth analysis of salaries offered by our diverse client base as well as income data provided by thousands of computer professionals we are in contact with on a regular basis.

Not only does our new report provide national median figures, it also breaks out salary data by individual market. In all, fifty position categories were surveyed in each of forty-six markets. Included are positions in programming, software marketing, software systems design, data communications, mini/micro systems, data base, computer operations, Edp auditing, computer marketing, sales, management, field service and others—at various levels of experience and at different size computer system sites.

A useful tool for career advancement.

The Survey is compiled by Source Edp, the world's largest recruiting firm that's devoted exclusively to the computer profession.

If you're wondering where your career and income are heading, the report just might be the most valuable compensation guide you'll

read and refer to often. It will not only help you evaluate your current career progress, but show you what skills are in most demand and what you can expect to earn in the future—with and without certain skill sets.

Call for your FREE report.

The new Survey is available at no charge to computer professionals. Call the Source Edp office nearest you to request a copy, with-

out obligation. As you'll discover, there's no better way to pinpoint salary levels with more precision or to gain insight into emerging opportunities. It could be the best reading you'll do all year.



The world's largest recruiting firm devoted exclusively to the computer profession.

Call today. ➔

Simply phone the Source Edp office nearest you *that's listed to the right*. A copy will be sent to you in strict confidence, without obligation. If unable to call, write:

Source Edp
Department B-2
P.O. Box 7100
Mountain View, CA 94039

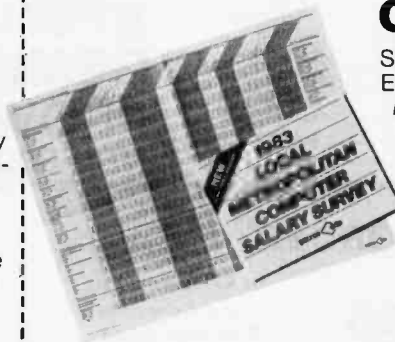

(When writing, be sure to include your title.)

Call Source Edp today.

United States:	
Arizona	
Phoenix	602/279-1010
California	
Northern	
Mountain View	415/969-4910
San Francisco	415/434-2410
Walnut Creek	415/945-1910
Southern	
Century City	213/203-8111
Fullerton	714/871-6500
Los Angeles	213/688-0041
Newport Beach	714/833-1730
San Diego	619/231-1900
Torrance	213/540-7500
Van Nuys	213/781-4800
Colorado	
Denver	303/773-3700
Connecticut	
Hartford	203/522-6590
Stratford	203/375-7240
District of Columbia	
Washington D.C.	202/466-5890
Florida	
Miami	305/624-3536
Georgia	
Atlanta	
Downtown	404/588-9350
North	404/953-0200
Illinois	
Chicago	312/861-0770
Rolling Meadows	312/392-0244
Indiana	
Indianapolis	317/631-2900
Kansas	
Overland Park	913/888-8885
Kentucky	
Louisville	502/581-9900
Louisiana	
New Orleans	504/561-6000
Maryland	
Baltimore	301/727-4050
Greenbelt	301/441-8700
Towson	301/321-7044
Massachusetts	
Boston	
Burlington	617/482-7613
Wellesley	617/273-5160
	617/237-3120
Michigan	
Detroit	313/259-7607
Southfield	313/352-6520
Troy	313/362-0070
Minnesota	
Minneapolis	
Downtown	612/332-6460
West	612/544-3600
St. Paul	612/227-6100
Missouri	
Clayton	314/862-3800
Kansas City	816/474-3393
New Hampshire	
Nashua	603/880-4047
New Jersey	
Cherry Hill	609/482-2600
Edison	201/494-2800
Morrisstown	201/267-3222
Paramus	201/845-3900
Princeton	609/452-7277
New York	
New York City	
Grand Central	212/557-8611
Penn Station	212/736-7445
Wall Street	212/962-8000
Rochester	716/263-2670
Syosset, L.I.	516/364-0900
White Plains	914/683-9300
Ohio	
Akron	216/535-1150
Cincinnati	513/769-5080
Cleveland	216/771-2070
Columbus	614/224-0660
Dayton	513/461-4660
Oklahoma	
Tulsa	918/599-7700
Oregon	
Portland	503/223-6160
Pennsylvania	
King of Prussia	215/265-7250
Philadelphia	215/665-1717
Pittsburgh	412/261-6540
Texas	
Dallas	
Central	214/954-1100
North	214/387-1600
Fort Worth	817/338-9300
Houston	
Downtown	713/751-0100
W Loop South	713/439-0550
San Antonio	512/342-9898
Virginia	
McLean	703/790-5610
Washington	
Bellevue	206/454-6400
Wisconsin	
Milwaukee	414/277-0345
Canada:	
Ontario	
Toronto	
Downtown	416/865-1125
Don Mills	416/425-5730
Mississauga	416/272-3333

;This procedure scans a buffer for a particular byte
 ;character and replaces it with another character. The
 ;parameters are passed in this order:
 ;The segment of the buffer
 ;The offset of the buffer
 ;The number of bytes to scan for
 ;A word whose low byte is the character to search for and
 ;whose high byte is the character to replace with

	PUSH	BP	
	MOV	BP,SP	
	LES	DI,[BP + 8]	;Get segment in ES and offset in ;DI using a double word in the ;stack (may have to tell assembler ;by LES DI,DWORD PTR[BP + 8])
	MOV	CX,[BP + 6]	;Length to search for
	MOV	AX,[BP + 4]	;AL contains character to search ;for and AH has character to ;replace with
	CLD		;Auto-increment
SEARCH:	REPNE	SCASB	;Scan buffer until AL matches
	JE	SWAP	;If a match swap the characters
	JMP	Done	;otherwise stop
SWAP:	MOV	ES:[DI - 1],AH	;Using DI with a - 1 displacement ;because SCAS does an increment of ;DI, transfer the new character ;making sure to use ES (and not ;DS) as the segment register ;In case the last match was also ;at the end of the buffer
	JCXZ	DONE	
	JMP	SEARCH	
DONE:	POP	BP	
	RET	8	

Figure 6: Scanning a buffer for a particular byte and replacing it with another character.

Mnemonic	Description of Operation
STC	Set Carry flag
CLC	Clear Carry flag
CMC	Complement Carry flag
STD	Set Direction flag
CLD	Clear Direction flag
STI	Set Interrupt-Enable flag
CLI	Clear Interrupt-Enable flag
HLT	Halt until interrupted or reset
WAIT	Wait for TEST pin active
ESC	Escape to external processor
LOCK	Lock bus during next instruction
NOP	No operation

Table 5: Processor-control instructions direct various 8086 functions.

the section on string instructions.

The CLI (clear interrupt) instruction disables the INTR signal from interrupting the 8086 by clearing the Interrupt flag. The STI (set interrupt) lets you recognize the INTR signal after the instruction following STI has been executed.

The HLT (halt) instruction stops the 8086 until either a reset or an external interrupt on NMI or INTR occurs. When an interrupt routine returns, the 8086 resumes execution with the instruction following HLT.

Systems often use multiple micro-

processors. Using more than one microprocessor results in increased system performance. The 8086 is designed to cooperate with other microprocessors via its hardware and software structures.

A special type of microprocessor, called a coprocessor, might share a program with the 8086, executing only the instructions pertaining to it and ignoring the 8086 instructions. For example, the 8087 coprocessor, a numerics data processor, performs floating-point and trigonometric functions. However, the 8086 must

PICK'EM

PREDICTS NFL GAMES
COMPLETE WITH POINT SPREAD
EASY TO USE

APPLE - DOS 4.8/APPLESOFT (5 1/4")
IBM PC - PC/MS DOS (5 1/4"SS/DD)
TRS-80 III - TRSDOS (5 1/4") or CASSETTE
ATARI - ATARI BASIC and 5 1/4" DISK (32K)
or CASSETTE (16K)
HEATH/ZENITH - HDOS or CP/M (5 1/4")
TIMEX/SINCLAIR - 16K RAM/CASSETTE

CAVES OF ZULU

Animated Adventure Fun
(16K TIMEX / SINCLAIR ONLY)

EACH ONLY \$19.95

Add \$2.00 S/H per order
(CA residents add appropriate sales tax)

STUART SOFTWARE

25381 - G Alicia Parkway

Suite 316

Laguna Hills, CA 92653

(714) 855-4753

Dealer Inquiries Invited



Circle 371 on Inquiry card.

U.S. Robotics Modems

300 / 1200 baud Auto dial / Auto Answer

New - Password \$374
New - Courier (for Osborne) \$414
New - S100 (for S100 Systems) \$374
Auto Dial 212A \$469
Telpac Communications Software \$ 69

Morrow Micro Decision

Includes 64K Ram, Z80A, CP/M, Wordstar
Spelling Checker, Logicalc, Basic,
MicroSoft Basic.

MD1 200K disk drive \$889
MD2 2- 200K disk drives
with Personal Pearl Data Base Manager \$1189
MD3 2- 384K double sided drives
with Personal Pearl and Quest Bookeping \$1589

* \$3.00 Long Distance Phone call credit with Purchase *

XL Systems

A division of Data Information Systems, Inc.
967 East 4800 South Suite 4C
Salt Lake City, Utah 84117
(801) 266-0454

APPLE IIe

80 COLUMN/64K BOARD

29.00

- ★ includes printed PCB
- ★ pictorial layout
- ★ list of commands
- ★ you add parts and labor
- ★ assembled **129.95**

ProWriter I 369.95

Parallel card w/cable 69.95

We also carry a full line of
Apple & IBM Hardware & Software

— add for —		DATA-RITE CORPORATION
Shipping	2.50	3086 Wheeling
COD	1.65	Aurora, CO 80011
2nd day air	2.00	(303) 366-5267
CO res. add 3 1/2% s/s tax		
VISA/MC WELCOME		

Circle 129 on Inquiry card.

DISK DRIVES

(For PC, Mod I, III & IV)

Tandon TM55-2 \$239
Tandon TM100-1 \$189
Tandon TM100-2 \$239
Tandon TM100-4 \$339
CDC 9409 call.

PC EXPANSIONS

MAYNARD
DISK CONTROLLER \$155
PP add \$50 SP add \$70

QUADRAM
Four Function 256K capacity
with 64K installed \$289

AST
ComboPlus:
64K+SPC+SuperDrive
+SuperSpool \$269
MegaPlus:
64K+SC+SuperDrive
+SuperSpool \$269
I/O plus(SQ) \$114
User installed.
2nd S or P or game \$ 35

VLM Computer Electronics

10 Park Place • Morristown, NJ 07960
(201) 267-3268 Visa, MC, Check or COD.

Circle 415 on Inquiry card.

know that an instruction coming in is for the coprocessor and not for itself. Therefore, coprocessor instructions are contained in an ESC (escape) instruction, which the 8086 will ignore. The coprocessor monitors the bus and, when an ESC comes in, captures its op code from the ESC instruction. If an operand from memory is involved, the 8086 fetches that operand (calculating the address) and discards it. The coprocessor can capture the operand or the address at this time from the bus as well; the 8086 then goes on to the next instruction while the coprocessor is executing this instruction.

Because a coprocessor might take a different time period to execute its instruction, there should be some coordination between the two processors. Before another coprocessor instruction comes in, the coprocessor should finish its current one. A pin on the 8086, called TEST, accomplishes this mission. The WAIT instruction looks at this pin and, if the pin is LOW, the 8086 will go on to the next instruction. But if the pin is HIGH, the 8086 will enter a wait condition. Therefore, the coprocessor can pull this pin HIGH until it is finished with its instruction. Most ESC instructions, and any 8086 instruction that looks at a coprocessor's results, should be preceded with a WAIT instruction.

Although multiprocessors can share memory and input/output devices, they must have their own programs. Often, they utilize the same buses to access common devices and take turns using this bus. Sharing, then, might involve some communication between multiprocessors. For example, microprocessor #1 could be filling a block of memory with new data while microprocessor #2 is reading that same block of memory. Without some notification, microprocessor #2 might get part of some old data and part of some new data.

The most common method of sharing a block of memory is to set up one location as a flag to let each processor know that this block is in use. Therefore, each microprocessor

S-100 EPROM PROGRAMMER

EPROM-32

- High quality S-100 board meets or exceeds IEEE-696.
 - Programs 1K through 32K (byte) EPROMs.
 - Textool zero-insertion-force programming socket.
 - EPROM is programmed through I/O ports and can be verified through I/O ports or located in memory space for verification.
 - Programming voltage generated on-board.
 - Personality Modules simplify adaptation of board to different EPROM types:
- | | | |
|----------------|------------------|------------|
| PM-1—2508,2758 | PM-3—2732, 2732A | PM-6—68764 |
| 2516, 2716 | PM-4—2564 | PM-8—27128 |
| PM-2—2532 | PM-5—2764 | |
- CP/M-compatible control software
 - Includes commands for programming, verification, disk I/O and editing.

\$269.95 *
(A & T)

MicroDynamics Corporation

6363 Poplar Ave • Suite 105
Memphis, TN 38119

ORDER DESK:
1-800-237-8400 ext 440
Technical Inquiries
1901-682-4054

*Price includes EPROM-32, documentation and two Personality Modules (specify). Additional Modules—\$795. Control software on 8" SSD diskette—\$9.95 UPS ground—\$2.00, UPS air—\$4.00, COD—\$1.50, foreign add \$15.00, TN add 6% sales tax. VISA and MASTERCARD welcome.

Circle 268 on Inquiry card.

64K for VIC 20™ SELECT-A-RAM™



SELECT-A-RAM

STANDARD FEATURES

- 18 BIKES SELECTABLE FROM THE KEYBOARD OR BY SOFTWARE COMMAND
- TWO EXPANSION MODULES
- WRITE PROTECTION
- RESET SWITCH
- EXPANDABLE TO 128K WITH ADDITION OF 84K EXPANSION MODULES
- COMPATIBLE WITH ROM CARTRIDGES
- ONE YEAR WARRANTY ON PARTS AND LABOR
- 15 DAY MONEY BACK GUARANTEE

SELECT-A-RAM \$169

84K EXPANSION MODULE \$169

TRADE INS ACCEPTED \$169

JK 55 BK510 16A-820 \$15.00

VIC 20 IS A TRADEMARK OF COMMO-DORE ELECTRONICS LIMITED

APS-52A

52K MEMORY FOR ATARI

400/800 \$119.00

The APS-52A memory expansion board

comes assembled and tested with 30 day

warranty covering material and workmanship

Details come with complete documentation

including operation and installation instructions

and a memory test program \$15.00

128 TRADE INS ACCEPTED

512-441-3202 PO BOX 43006 Austin, Tx. 78745-0001

ADVANCED PROCESSOR SYSTEMS

Circle 13 on Inquiry card.

www.americanradiohistory.com

THE BENCHMARK[®]

- Word Processor
- Mail List
- Telecom
- Spelling Checker

A Family of Highly Developed Software for Your Personal Computer

WE KEEP GOOD COMPANY

Dealers

Liberty Computer Sales
Tempe, AZ
(602) 949-8218
(800) 328-8905 outside AZ

Compusales
Lawndale, CA
(213) 370-3224

K.J. Murphy & Company
San Francisco, CA
(415) 391-5950

Compumax
Gainesville, FL
(904) 375-7737

Advanced Business Systems of Jax
Jacksonville, FL
(904) 396-4414

InfoSystems, Inc.
Tampa, FL
(813) 223-5266

Atlanta Software House
Decatur, GA
(404) 292-2146

Major Mill, Inc.
Glenwood, IL
(312) 755-2500

(800) 323-8832 outside IL

Southern Computer Systems
Shelbyville, KY
(502) 633-5639

Soft Supply & Systems
Burlington, MA
(617) 229-6666

Invent Software, Inc.
Mineola, Long Island
(516) 294-7670

J.A.M. Computers, Inc.
Long Island, NY
(516) 543-3770

Legal Computer Applications, Inc.
Long Island, NY
(516) 488-3338

Hasiba/Harris Assoc.
New York, NY
(212) 929-0104

Advanced Data Technology Corporation
Greenville, OH
(513) 548-7747

The Software Place
Austin, TX
(512) 453-0851

Houston, TX
(713) 781-1488

Marshall Business Equipment
Marshall, TX
(214) 938-8371

Business Computer Systems, Inc.
Salt Lake City, UT
(801) 967-0820

H & H Computer Enterprises, Inc.
Blacksburg, VA
(703) 552-0599

micro MAX
Reston/Herndon, VA
(703) 471-4156

Byte Size Solutions, Inc.
Seattle, WA
(206) 783-9599

Total Computer Center
Washington, D.C., Metro
(703) 836-8188

Faxx Computer Center
Langley, B.C. Canada
(604) 875-1221

Vancouver, B.C. Canada
(604) 533-5337

Distributors

Electrical Equipment Company
Phoenix, AZ
(602) 275-7801

Software Resources
San Rafael, CA
(800) 851-9009
(800) 851-9010 outside CA

Computers, Plus
Tallahassee, FL
(904) 386-6635

Van Ausdall & Farrar Inc.
Evansville, IN
(812) 424-5736

Fort Wayne, IN
(219) 432-1547

Indianapolis, IN
(317) 634-2913

South Bend, IN
(219) 289-4006

Soft Source, Division of Continental Resources
Boston Metro, MA
(617) 275-2175

K.R. Computing
St. Louis, MO
(314) 721-3168

Professional Automated Systems, Inc.
Columbus, OH
(614) 890-1095

(800) 231-1367 outside OH

Lone Star Micro, Inc.
Dallas, TX
(214) 521-2931

(800) 527-5078 outside TX

Futech International Corporation
Grand Prairie, TX
(214) 660-1955

The Benchmark is a federally registered trademark of Metasoft Corporation.

Metasoft Corporation • 6509 West Frye Rd. • Chandler, Ariz. 85224 • (602) 961-0003 • (800) 621-1908

"FANTASTIC! SIMPLY FANTASTIC!"*

Inexperienced users just love it!
Professionals won't part with it!
Self-demo, compare and discover
what makes

CUMSEA

the most highly acclaimed Apple II
editor/assembler ever developed.

- Disk Based
- Menu Driven
- Syntax Checker
- Screen Editor
- Mainframe Performance
- 4 Additional Programs
- Interactive Assembler
- 83-Page User Manual

\$69.95 at dealers. If not yet available locally,
mail order directly from plant (\$67 refunded if
returned in 60 days).

Special offer to educational institutions for
\$26.50 EX PLANT - contact the plant for
endorsements, literature, etc.

US Distr. JAMSoftware, 18000 Pacific Hwy South,
Suite 511, Seattle, Washington 98188 Ph: (206) 644-3468
UK Distr. Lesley Software, 38 Forlease Road,
Maidenhead, Berkshire, England SL6 1RU Ph: 0628 35437
Plant - Custom Micro Systems Ltd., 16921 - 108 St.,
Edmonton, Alberta, Canada T5X 3B2 Ph: (403) 456-0974

* One of many unsolicited testimonials

Circle 123 on Inquiry card.

LOWEST PRICES

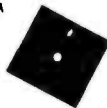

BASF Qualimetric Diskettes

- Same-day shipping
- Dealer Inquiries Invited
- VISA/MC accepted

Call Toll Free
(800) 221-3460

In CA, call **(800) 821-6668**



3024-B De la Vina
Santa Barbara, CA 93105
(805) 687-7143

Circle 256 on Inquiry card.

YOUR NAME HERE

PERSONALIZED COMPUTER PAPER

Printed with your name, club, anything.
Paper is white 20# stock and fits all printers
using 9 1/2 x 11 continuous paper [8 1/2 x 11 when detached].

500 sheets \$14.95, 1000 sheets \$24.95. We pay shipping.

Texas orders add 5 1/2% tax. Select ink color: red, blue, brown, gray, or canary. Specify name[s] up to 30 letters & spaces. Enclose check or money order. No COD's. Allow 3 weeks. Faster delivery with M/C, Visa phone orders. Write or phone **Personalized Computer Paper B**, Box 20539/San Antonio, Tx. 78220/ (512) 227-0585.

Circle 387 on Inquiry card.

UNIX* & C STARTER KIT -

ONLY \$50 (Extra Special kit price)

- One copy of *Introducing the UNIX System* by McGilton & Morgan, a highly-acclaimed introduction and reference book with over 550 example-laden pages.
- Two years of *World UNIX & C*, a quarterly magazine serving the growing community of UNIX and C users with news, reviews, features and advertising.
- One copy of *C Primer* by Hancock & Krieger, a best-selling introduction to reading and writing C programs.
- One coupon good for 10% off your next order of computer language reference materials from our comprehensive library.
 - Free software books catalog with every order.
 - Full money-back for returns within 15 days.
 - Special kit prices good for prepaid and credit card orders only.
 - Phone 203-288-0283 for credit card orders.

- Southwater Corp. -

30 Mowry St. - Mt. Carmel CT 06518

*UNIX is a trademark of Bell Laboratories

Circle 77 on Inquiry card.

PERIPHERALS FOR APPLE II AND IIe

ONE YEAR WARRANTY ON ALL ITEMS

	EACH	BARE BOARD
APPLE/SHUGART DRIVE (5 1/4")	\$199	
DISK CONTROLLER (DOS 3.2-3.3)	69	\$ 21
80 COLUMN CARD (VIDEX EQUIVALENT)	139	29
132 COLUMN CARD (II + DR IIe) (ULTRATERM EQUIVALENT)	CALL	29
80 COLUMN WITH 64K RAM (FOR IIe ONLY)	129	28
PRINTER INTERFACE WITH 16K TO 64K BUFFER AND GRAPHICS (APPLE DUMPLING EQUIVALENT)	139	29
MULTI-FUNCTION CARD (PARALLEL, SERIAL, BSR, CLOCK) (VERSA CARD EQUIVALENT)	136	29
IBM (PC) BARE BOARD	--	175.
5 1/4" FLOPPY DRIVE ENCLOSURE	17	
280 SOFTCARD (II + AND IIe) (MICROSOFT EQUIVALENT)	99	29

COLORADO COMPUTER PERIPHERALS

R.R. 6, BOX 7-D GOLDEN, CO 80401

(303) 278-7172

agrees that if this location contains a hexadecimal 01, the block is in use. The microprocessor must then set it to 1 if it is using that block when the flag is clear. A simple method is to move a 1 into the AL register and exchange the AL register with this flag location. If after this exchange AL is still a 1, then you know that the block is being used by another processor. But if AL is zero, then the microprocessor can use this block, and the flag location is already set to 1 by the XCHG instruction.

However, there is one problem with this setup. The microprocessor must use the bus twice to do the XCHG instruction; once to read the memory contents and once to write the contents of the AL register in this location. However, in between these operations another processor might get in there and do the same thing, and you once again have the same problem. The 8086 has provided a prefix called LOCK in its instruction set. Any instruction preceded by the LOCK prefix gains total control of the bus for the entire instruction; no other processor can gain bus use until that instruction is done. This instruction affects one 8086 pin, called LOCK, which causes the hardware to lock the bus.

Conclusion

You have perceived the many advantages that the 8086 offers programmers. Its addressing lets you access many types of operands for your instructions and accommodates different types of program development. The instruction set is versatile, and added operations make the programming task easier. The 8086 supports high-level languages with memory-based variables and produces compact code.

I hope that this series of three articles will help you when you work with the 8086, whether you are programming it or debugging its listings. ■

Stephen Heywood is an instructor with Intel Customer Training and is involved with preparation of the 8086 course. He can be contacted at Intel Corporation, 27 Industrial Ave., Chelmsford, MA 01824.

SAVE UP TO 50% ON Floppy Disks & Computer Supplies

We Discount the Top Brands
**3M-Scotch® • Verbatim® • Dyan
Memorex • BASF • Maxell®**

We also stock
**Ribbons • Paper • Labels
Cleaning Kits • Printwheels
Storage Products**

Call, write, or utilize Reader
Service for our FREE new
DISCOUNT catalog

LYBEN COMPUTER SYSTEMS

27204 Harper
St. Clair Shores, MI 48081
(313) 777-7780

offering Reliability and Same Day Service.

Circle 242 on Inquiry card.

www.americanradiohistory.com

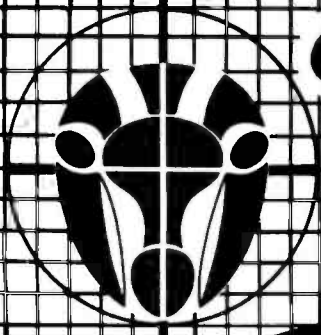

ORYX SYSTEMS inc.

QUALITY DISCOUNTS

for a complete selection of microcomputer hardware, software and accessories.

Apple/Franklin

- ASHTON-TATE**
 - D-Base II \$ 450
- ASPEN SOFTWARE**
 - Grammatik \$ 60
 - Proofreader 42
- BRODERBUND**
 - Bank Street Writer . . . \$ 55
- CALIFORNIA COMPUTER**
 - 7710 Async Serial Interface \$ 130
- CDEX**
 - *Visicalc Training . . . \$ 45
- CHARLES MANN**
 - Basic Teacher \$ 30
 - Teacher Plus 32
 - MedCalc II 879
 - Class Scheduling . . . 299
- CONTINENTAL SOFTWARE**
 - Home Accountant . . . \$ 55
- DOW JONES**
 - Market Analyzer . . . \$ 279
 - Market Manager . . . 240
 - Microscope 569
- HOWARD SOFTWARE**
 - Creative Financing . . . \$ 145
 - Real Estate Analyzer . . 145
- KRELL CO. Logo (MIT)** . \$ 75
 - Abelson Book 15
- LINK SYSTEMS**
 - Datafax \$Call
 - Datalink 79
- MICROPRO**
 - WordStar (Special) . . . \$ 375 (W/CP-M/70 col/64K)
 - Infostar (Includes CP-M/70 col/64K) . . 375
 - Pro Pak (WS/MM/SS/index) . 399
- MICROSOFT**
 - Cobol-80 \$ 499
 - Fortran-80 145
 - TASC Compiler 125
 - A.L.D.S. 99
 - Multiplan (DOS) 89
- MOUNTAIN COMPUTERS**
 - A to D & D to A (w/o cable) \$ 299
- OMEGA**
 - Locksmith \$ 75
 - Inspector 47
 - Watson 44
- PEACHTREE (CP/M)**
 - Peachpak 40 G/L + A/R + A/P (Special) . . . \$ 359

- Series 40
 - G/L, A/R, A/P ea. . . . 225
 - Inventory 225
- Series 9
 - Peachcalc 279
 - Telecommunications . . 279
- PENGUIN SOFTWARE**
 - Complete Graphics . . . \$ 53
 - Graphics Magician . . . 45
- SUPERSOFT**
 - Basic Tutor \$ 79
 - Fortran 325
- SYSTEMS PLUS (Z80 req.)**
 - Landlord 375
- TERRAPIN Logo** . . . \$ 115
- VISICORP**
 - Visicalc (II or IIE) . . . \$ 179
 - Visischedule 225
- MISC.**
 - ISM Mathmagic \$ 69
 - ISA Spellguard 199
 - LJK Edit 6502 82
 - On-Line Screen Writer II 95
 - PFS: Filing, Report or Graph 112

CP/M

- ASHTON-TATE**
 - D-Base II (8" only) . . . \$ 399
 - D-Base II (other CP/M) . \$Call
 - FPL 495
 - Bottom Line Statelist 299
- SOFTWAREBANC**
 - D-Base User's Guide w/ D-Base Purchase . \$ 15
 - w/ D-Base Purchase . 20
- COMPUVIEW**
 - V-Edit 8080 Z80, IBM PCs 130
 - V-Edit CP/M86, MS DOS 160
- DIGITAL RESEARCH**
 - Pascal Mt + W/SP . . . \$ 389
 - MAC 85
 - SID (8080 Debugger) . . 68
 - ZSID (Z80 Debugger) . . 90
 - CP/M 2.2 140
 - C Basic 2 110
 - PL1-80 425
- FOX AND GELLER**
 - Quick Screen \$ 125
 - Quick Code 209
 - D-Util 69
- LEXISOFT**
 - Spellbinder \$ 275
- MARK OF UNICORN**
 - *Final Word \$ 239
- MICROPRO**
 - *WordStar \$Call
 - *InfoStar 275

- Pro-Pack (WS/MM/SS Index)** \$Call
- MICROSOFT**
 - Basic 80 \$ 249
 - Basic Compiler 289
 - Fortran 80 330
 - Cobol 80 499
 - Macro 80 150
 - MuMath/MuSimp . . . 199
 - *Multiplan 199
- OASIS**
 - *The Word Plus . . . \$ 120
 - *Punctuation and Style . 99
- PEACHTREE**
 - *Peachpak 4 (G/L, A/R, AP) (Special) . . . \$ 359
 - General Ledger Series 4 399
 - Accounts Receivable Series 4 399
 - Accounts Payable Series 4 399
 - Inventory Series 4 . . . 399
 - CPA Client Write-up . . 399
 - Series 8 Modules each 425
- PICKLES & TROUT**
 - CP/M \$ 170
- PROTEM SOFTWARE**
 - *Footnote \$ 105
- REVASCO**
 - Z80 Disassembler . . . \$ 85
- SORCIM**
 - *Supercalc II \$ 199
 - Superwriter (W/Speller & Mailer)
- STAR COMPUTER SYSTEM**
 - G/L, A/R, A/P or Pay . . \$ 350
 - Legal Time, Billing . . . 845
 - Property Management . . 845
- SUPERSOFT**
 - Diagnostic II \$ 90
 - Disk Doctor 84
 - Fortran 4 305
 - Basic-8086 225
 - Lisp 120
 - Z8000 Assembler . . . 400
 - C Cross Assembler . . 400
 - *ScratchPad 219

IBM PC

- IBUS EasiSpeller** 99
- Alpha DataBase**
 - Manager II 170
- Alpha Mailing List** . . 85
- Woolf Move II** 125
- Financier**
 - Personal Series . . . 159
 - TAX Series 129
- Sorcim Supercalc II** . . 199
- Lifetree Volkswriter** . 145
- Ecosoft Microstat** . . . 257
- Northwest Statpak** . . 397
- Organic Software**
 - Milestone 269
 - Datebook II 269
 - Microstuf Crosstalk . . 139
 - Copy II PC 34
 - *Infostar \$Call
 - Landlord (prop. mgmt.) \$ 375

Accessories/Hardware

- APPLE/FRANKLIN**
 - CoProcessors 88 card . \$ 795
 - Softcard (Z80 CP/M) . . 245
 - Videx 80 Col. Board . . 239
 - Microsoft Premium Pak 489
 - Videx Enhancer I . . . 149
 - K & D Enhancer 115
 - ALS-CP/M 295
 - ALS Smartterm 379
 - ALS Z-card 149
 - Versacard 160
 - Bit 3 Dual Comm-plus . 209
 - 16K RAM WIZARD . . . 79
 - Microsoft 16K RAM . . 79
 - Echo II Speech Synthesizer . . 159
 - East Side Software Wild Card 110
- IBM PC**
 - BYAD DS-II (64K, Z80, CP/M) . . \$ 599
 - Datamac 64K 399
 - Zedex Baby Blue . . . 475
 - Quadram Quad Board . 325
 - Quadram 128K Ram . . 425
 - AST Combo + 64K w/serial & parallel port . . . 350
 - *Hercules Graphics Board 369
 - Orchid Monochrome Graphic Adptr. 432
 - QuCes Big Blue 499
 - Vista Maxicard 64K . . 325
- MISCELLANEOUS**
 - Percom Doubler II . . . \$ 167
 - Symtec Light Pen (IBM PC) 140
 - Symtec Light Pen (API/III) 200

- Microfazer 8K Printer**
 - Buffer 135
- Maynard Floppy Drive**
 - Controller w/Par. Port (IBMPC) 229
- Prometheus (64K upgrade)**
 - Apple Surance 120
 - 64K Upgrade 75

COMPUTERS Franklin/Televideo Nec/Xerox — Call for Price Information

- MONITORS & TERMINALS**
 - PGS RGB Color \$Call
 - Amdek Video 300 . . . 160
 - Amdek RGB Color . . . 579
 - NEC 12" Hires Green . 159
 - Sanyo 12" Hires Green 199
 - USI Hi-RLS 12" Amber . 199
 - Zenith ZVM 12" Green . 115
 - Quadchrome \$Call
- MODEMS**
 - Novation Apple-Cat II . \$ 269
 - Novation 212 Auto Cat 585
 - Hayes Smartmodem . . 209
 - Hayes Smart Modem 1200 499
 - Micromodem II 319
 - Hayes Chronograph . . 189
 - US Robotics:
 - *Auto-Dial (Full Auto300/1200) . . 459
 - Auto-Link (Auto Answer300/1000) . . 379
 - Password 395

- PRINTERS**
 - C. Itoh Starwriter . . . 1450
 - C. Itoh Prowriter . . . 485
 - GE Printers \$Call
 - Generic Prowriter . . . 425
 - NEC 3530 1850
 - NEC 3550 \$Call
 - NEC 8123A 489
 - Okidata Microline 82A . 439
 - Okidata Microline 83A . 685
 - Prism 80 (w/4 options) color 1399
 - Prism 132 (w/4 options) 1547
- DISK DRIVES**
 - Rana Elite I (AP II) (Special) \$ 299
 - Rana Elite II 420
 - Rana Elite III 550
 - CDC 1800 270
 - Tandon TM-100-2 . . . 250
 - Tandon TL-55-2 275
 - Corona Hard Disks . . . \$Call
 - Davong Hard Disks . . . \$Call
 - Tandon Hard Disks . . . \$Call

ORDER TOLL FREE - Outside WI - 1-800-826-1589

- Please:**
- Wisconsin residents — add 5% for sales tax.
 - Add \$3.50 for shipping per software and small items. Call regarding others.
 - Foreign — add 15% handling & shipping for small items & software.
 - Prices subject to change without notice.
 - All items subject to availability.

- We welcome:**
- Visa, MasterCard & American Express — (Add 4%)
 - Checks (Allow 1-2 weeks for clearing)
 - COD (Add \$2.00 per shipment — cashiers check required)
- Working Hours:** Mon.-Th. 8:30-5:30 • Fri. 8:30-6:30 • Sat. 10:00-2:00
- For technical information & in Wisconsin: 715-848-2322
Store prices differ from mail order.

ORYX SYSTEMS, INC.

205 Scott St. • P.O. Box 1961
Wausau, WI 54401
Int'l. Telex — 280181
ORYX SYS WAU



Book Reviews

CBASIC User Guide

Adam Osborne, Gordon Eubanks Jr., and Martin McNiff
Osborne/McGraw-Hill
1981; 214 pages
softcover, \$16.95

Reviewed by
Dr. Bruce R. Evans

"The CBASIC language may be the most advanced version of BASIC yet created."

Adam Osborne never was wishy-washy! Don't, however, let this outrageous quotation from the cover of *CBASIC User Guide* put you off. CBASIC is a super language, with lots of business software written in it. If you are going to modify any of these programs or write your own, you need this book.

Much of the book's information is included in the documentation that comes with CBASIC, but the CBASIC manual is poorly written, edited, and printed. Not so with the *CBASIC User Guide*. As an example, six pages of error messages, their causes, and program responses to them tell more than the reference manual's ten pages. For this reason alone, any CBASIC programmer needs this book close by.

This book is more than a reference. Rather than dole out a single line demonstrating each command, the authors illustrate commands in the context of entire subroutines. Their discussion of the differences between and uses of WHILE...WEND and FOR...NEXT loops opened my eyes. In your BASIC, does a dimensioned variable start with the subscript 0 or 1? My manual doesn't mention this, but the *CBASIC User Guide* not only does but further explains how

this can affect memory size. CBASIC supports compound IF statements, but I wouldn't have known this from the manual—score another plus for this book, which tells me about this.

This book is filled with meticulously written short programs that you should enter and run. By doing this, you can feel the language, get used to good programming style, and learn useful concepts without realizing it.

A few programs are not so short: the authors go into a great deal of detail about the video display input and output of programs. Here is an area in which many experienced computer users have a blind spot. The authors reminded me that, not only do most business users of personal computers not know the things programmers take for granted about the use of personal computers—how to signal the end of input by hitting the Return key, how to format their response to an INPUT statement—they are actually afraid of the machines. This makes programs that are fault-tolerant and easy to use a necessity. They also remind us that CBASIC programs should be made to run correctly on terminals that use different commands to manipulate the video display.

By itself, chapter 11 on file structure makes the book invaluable. What files are about, how they are arranged, and how we affect them are all fully discussed here. The chapter also talks about the dangers of leaving files unclosed, how this can accidentally happen (such as by inputting Control-Z), and how to program around these problems. Seven sample programs give a feel for handling sequential and random-access files. If you are not comfortable with files after reading

this chapter, you never will be. Again, the basic information is available in the CBASIC manual, but it's not well explained there.

Does this book have any failings? Yes, it does have a few. The title is misleading. It should be *CBASIC Version 2 User Guide*. Because of significant differences between version CBASIC 2.x and earlier versions, you should not use this book if you have an earlier version.

A strong point of CBASIC is that it allows 31-letter variables; a weak point of this book is that the authors tend to use all 31 letters in their examples. To the uninitiated, it is confusing to see examples that use such variables as THIRTY.DAY.MONTH% or a line such as

```
MTD.PAY=MTD.PAY+
FN.NEAREST.CENT
(NETPAY)
```

Although long variable

names are invaluable in documenting a program, they are needless complexities when illustrating the programming language itself. Finally, was it really necessary to include six pages of hexadecimal-decimal conversion charts at the end? This leaves the reader wondering if the writer is paid by the page!

The *CBASIC User Guide* is produced in the tradition of all Osborne books. It is well written, well printed, and high priced. I think the first two features justify the third. I recommend this book to anyone using CBASIC and even more to anyone who isn't using it yet. ■

Bruce Evans is a family physician with a hobby interest in electronic computing who practices in Toronto. He can be reached at 16 Marwin Rd., Pickering, Ontario, L1V 2N7 Canada.

BYTE's Bugs

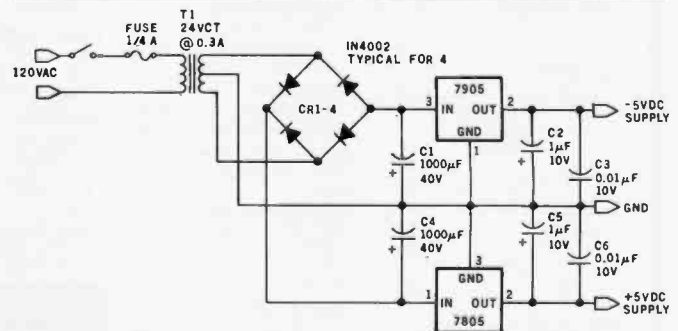

Bad Resolution In Power Supply

A drafting error marred the System Notes article "A High-Resolution Analog-to-Digital Converter for the TRS-80" by James Cameron (February 1983 *BYTE*, page 378). The schematic diagram of the suggested power supply, shown in figure 2 on page 384, contained a reversed set of pin numbers for the 7905 voltage regulator.

Furthermore, the capacitors were not properly specified and some of their polarities were reversed.

For the benefit of our readers who may want to build that power supply, the corrected circuit is shown here above. Our apologies to those of you who were inconvenienced.

Our thanks to Michael H. Butler of Beltsville, Maryland, and others for pointing out the problems. ■

These career opportunities are already yesterday's news.



Now there's a source of employment information as technically advanced as the job openings it offers.

It's called CLEO. It's Computer Listings of Employment Opportunities. A few minutes on your personal computer with CLEO and you've got the inside story on today's fast-changing technical career market.

CLEO is classified advertising that talks back. You're guided through every step by explicit on-line instructions. You tell CLEO what job categories, companies, or geographic locations interest you. Then CLEO calls up the appropriate ads right on your screen.

CLEO job listings are updated daily, and access to the system costs you nothing but the price of a phone call. You can even apply for positions right from your terminal. If you're looking, or just curious, don't reach for today's paper—it may already be out of date. Reach for your computer terminal. And CLEO.

CLEO access: **(213) 618-8800**

300 BAUD, full duplex, standard ASCII code. Access assistance: (213) 618-1525. An electronic publishing activity of The Copley Press, Inc.

Today's career news is right here.

Recruitment advertisers — call (213) 618-0200 collect to find out how you can place your ad on CLEO.

Circle 113 on inquiry card.



Book Reviews

An Assembly Language Course

Mark Fohl
Petrocelli
1982; 169 pages
hardcover, \$17.50

Reviewed by
Tim Kilby

Remember sweet Miss Fenwick, your eighth-grade math teacher? When you left her class you really felt you had learned something. She knew just how to explain all the details. You weren't forced to memorize; you learned to reason out solutions to problems. And she offered fun extras that helped you get the broad picture of what math was all about. Looking back, you remember that you didn't feel pressured in her class; eighth-grade math wasn't really heavy stuff to learn when it was explained properly. You were building a foundation for everything that was to come in all the advanced mathematics classes.

That's the way you will feel about *An Assembly Language Course*: unpressured and easygoing—a sturdy footing for future study. Not at all a bad way to be introduced to assembly language.

Let's face it. Only the Marquis de Sade could enjoy programming in assembly language. Even if it had a fancy French name it wouldn't be more palatable. But there comes a time when resistance must be replaced with the spirit of challenge and the promise of efficient, fast code. At that time, *An Assembly Language Course* should be on the top of your reading list.

Author Mark Fohl should be commended for providing a "generic" approach to assembly language. His choice of the Motorola

MC6800 microprocessor and its instruction set should not alienate users of other microprocessors. In fact, those of you with other computers (myself included; I have the 6502) will benefit greatly by his instruction. Because I was not expecting to be a full-fledged assembly programmer by the last chapter, I was able to concentrate on principles, logic, and operations.

There is a laconic discussion of the 6800 architecture and instruction set, which you will find valuable in studying your microprocessor's structure. While not confusing the reader with instruction sets of other processors, Fohl does suggest similarities to look for. His first-class explanation of the binary number system, as it is used in assembly language, is excellent reading for novices trying to understand how computers work. And a short source-code listing of a radix-converter routine (binary, octal, decimal, or hexadecimal) is not only useful as a learning tool, but it would be a great utility program to have on file.

Don't expect to write a new Alien Invaders game after reading *An Assembly Language Course*, however. You'll need a good reference book for your specific microprocessor and a lot of experience writing simple routines in assembly before you tackle any big jobs.

Perhaps the most important topic discussed in the text is the assembler programs themselves: what they are, how they work, and how they differ. (Even assembly language, as close as it is to the computer's own language, must be converted into machine-readable code.)

Other questions answered include the following. What is an assembler, exactly? And how does the two-pass as-

sembler affect the readability of source code? When are cross-assemblers and macro assemblers preferred? Why would you want an assembler capable of conditional or relocatable assemblies? All these issues are discussed for the reader's complete understanding of the assembly-language process.

I can by no means be considered an experienced assembly-language programmer. I've learned by necessity to write subroutines that will speed my BASIC programs or do tricks otherwise unattainable. By spending many hours poring through reference books, by reading what assembly source code I could get my hands on, and by annoying knowledgeable friends, I have learned what I need.

I would have had it much easier if I had just possessed *An Assembly Language Course*. Then those pseudo-ops and addressing modes, and the LDAs, CLCs, BNEs, and JMPs, would not have been so confusing. And I would not have had to stare blankly so often at the person telling me about the latest

such-and-such macro assembler.

Assembly language need not be as punishing as all that for you. Many of you may take to assembly coding quicker than a dog takes to its bark. Fohl's book may even be too light for a few of you. For almost everyone, though, it should prove to be a tasty first course in a promising feast.

Miss Fenwick knew the most efficient way to get you thinking for yourself. She made sure you had the solid background you needed. Ever since that class you've been glad for having her as your teacher. Think of *An Assembly Language Course* that way. It's not the complete picture of assembly language—no book is, nor should be. It just sets the stage with efficient and concise explanations. Miss Fenwick would approve. ■

Tim Kilby is a microcomputer programmer and computer consultant. His article "Character Editor for the Atari" appeared in the December 1982 BYTE. He can be reached at RR 1, Box 288-B, Sperryville, VA 22740.

BYTE's Bugs

Faulty Philosophy

In trying out the 32-bit multiply program in Thomas Starnes's article "Design Philosophy Behind Motorola's MC68000," Robert Delaney found a bug. (See the May 1983 BYTE, p. 342.)

In listing 1, the instruction ADDQ #4,A7, which appears as the second to last instruction on page 358, should be deleted. It causes an incorrect result and does not allow restoration of the stack pointer to its entry value upon completion of the last instruction.

Breakout Box Broken

Two circuits using the LM324 op amp in Steve Ciarcia's "Build an RS-232C Breakout Box" will not work properly in their present configuration. (See figure 3, page 38, and figure 4b, page 41, in the April 1983 BYTE.) Reversing the input connections will correct this drafting error.

Our thanks to Harold Balyoz in Flagstaff, Arizona, for spotting this mistake. ■

Aural Gratification

With the ECHO speech synthesizer from Street Electronics whatever you type on the keyboard, your computer can say. The ECHO's text-to-speech system gives your computer an unlimited vocabulary while using a minimum of memory. And now a diskette of fixed, natural sounding words is available to enhance the ECHO II's voice output.

Nearly 400 language rules are contained in the ECHO's text-to-speech algorithm. These rules enable the computer to pronounce most correctly spelled words. When in the text-to-speech mode the user can select any of 63 different pitch levels, and have words spoken either monotonically or with intonation by using simple control character sequences. The rate of speech can be fast or slow; words can be spoken in their entirety or spelled letter by letter. The ECHOs also pronounce punctuation and numbers. Words can be encoded using phonemes and diphthongs when the text-to-speech or fixed vocabulary is not required.

Applications are unlimited, ranging from phone answering, educational and training programs, to games and aiding the sight and speech impaired. The ECHO is a complete stand alone unit which is compatible with most any computer; it sells for \$299.95. The ECHO II, which plugs into the Apple II, is priced at \$149.95.

Contact us about the ECHO/PC for the IBM Personal Computer.



Street Electronics Corporation

1140 Mark Avenue Carpinteria, CA 93013

Telephone (805) 684-4593

Call toll free for demonstration (800) 221-0339

Epson QX-10, Zenith Z-29, CP/M-68K, and More

Significant subjects are surveyed by our sagacious savant

by Jerry Pournelle

They say April is the cruelest month. It certainly was for me. April began with a trip to Houston for the L-5 Society Space Development Convention. I went directly from Houston to Ithaca, New York, where I delivered the C. P. Snow Memorial Lecture; from there to New York City to see agents and editors; direct (well, it was supposed to be direct until United Airlines managed some interesting routing) from NYC to Santa Cruz for a conference of anthropologists and science-fiction writers; back home in time to do my taxes; and north for a week in Washington state, where several scenes from our next book are set. Somewhere along the way I threw my back out.

Withal I managed to play about with the Epson QX-10 computer; we have CP/M-68K for the Sage; and there's a nifty new terminal from Heath/Zenith. I even managed to answer some mail, although, alas, not all I would like to have dealt with.

The Epson QX-10

The Epson QX-10 is now available, and I'm told it's selling well. It comes in two models: with a fairly standard keyboard that has a number of special-function keys marked in the usual manner and with the HASCI keyboard designed by Chris Rutkowski of Rising Star Industries.

The "standard" keyboard model comes with CP/M software; the HASCI model comes with Rising Star's Valdocs software package. You're also supposed to get a disk with the CP/M operating system. I don't have that yet. By the time you read this, however, it will surely be included with any package you could buy.

First the machine itself: I love it. The Epson QX-10 is compact and handsome enough that my wife will even allow it in the living room. The keyboard is very nice. It's missing some keys, such as tilde and curly braces { ~ ~ }, but there are ways to make it produce them.

The keyboard is very typewriter-like; it even preserves some annoying typewriter features. For example, the Shift Lock is not an "alpha lock" but a true shift lock: it puts the numbers and punctuation marks in uppercase. Also, it falls out of Shift Lock when you hit the Shift key. These are features, not bugs, according to Epson: it wants the machine to be so much like a typewriter that anyone familiar with one will be able to use the QX-10 without any adjustments.

The QX-10 has many nifty features. Little lights on certain keys, such as Insert and Shift Lock, tell you what mode you're in. When you first power up the Epson, it goes through

a series of internal checks (not described in the manuals I have, so I can't say precisely what) that flash all the lights in sequence.

The screen is pretty. The character set is nice, and a single keystroke lets you put in **boldface** and *italic* text that actually look like **boldface** and *italic* on screen. In other words, there's just a *lot* to like about the Epson QX-10.

Alas, there are also things to dislike. Not about the hardware; if the Epson has any hardware problems, I'm not aware of them. I've never had a hardware problem with the machine, and I'm very fond of its little half-height 5¼-inch double-sided double-density disks.

The problems are in the Valdocs software.

Valdocs is an enhanced text editor intended for the absolute novice user. You can do just about anything you like from within the editor; it's like an operating system. For example, there's a full four-function calculator with memory; the results can be put into your document. You can also use the Calculator mode to sum up columns of numbers; I used it to prepare my expense accounts for my April trips. Like Wordstar, there's provision for running specific outside programs: I presume that one of these days there'll be things like spelling checkers, footnotes, and the like.

The Valdocs system is *very* easy to

The personal, portable daisywheel printer.

Only \$599.

For the first time, your letter-quality printer can be used almost anywhere! Bring the new Transtar 120 with you to work, to school, and home again! Conveniently weighing in at less than 18 pounds, it generates unrivaled print quality and is the size of a standard briefcase. The new 120 is so light, so small, that you can take it with you!

Remarkably, the new \$599 Transtar 120 is "plug and go" compatible with the best-selling word processing programs. Just plug the 120 into your personal computer and watch this precision printer purr along at 14 cps Shannon text speed producing superscript, subscript, underlining and a true boldface. Even using letterhead is now a breeze with the 120's automatic single sheet loading!

Don't worry about durability: it's a tough little machine. It joins the highly reliable family of Transtar printers with a failure rate that's the envy of the industry: less than 1%. Should your 120 ever need repair, a nationwide network of authorized service centers stands ready for speedy repair on your six-month end-user warranty.

Just think of it: everything you want in a letter-quality printer...anywhere you want it. Only \$599.

Transtar

P.O. Box C-96975, Bellevue, Washington 98009

Circle 396 on Inquiry card.

learn. You don't have to open a single document. You just start using it, and soon you can type letters and such like. Online help is available at all times, and a big Undo key will pretty well cancel anything you just did and don't like.

There are a number of other helpful features. There's a communications system that's supposed to work with an optional modem; I don't have that, so I can't say how well it works, but from the description it sounds pretty good. The mail

management system also includes a "card file" system that lets you keep names, addresses, and telephone numbers, and get at them from inside the text editor.

The Valdocs system creates a kind of database with multiple index entries for each file you've saved, so that it can display your file directory in a number of ways: sequential, alphabetical, or, because you can have multiple-word file names, as a cross-indexed directory listing.

The system has a Schedule func-

tion that keeps track of dates and appointments in an electronic date-book. That too is accessible from within the text editor.

In other words, Valdocs is really splendid in conception, being a lot of what I've always wanted. The trouble is, you pay a high price for all these features.

The first problem is obvious from the other side of the room. The Valdocs system is *slow*. It seems to take forever to do disk operations. There's a reason, of course: when Valdocs saves a file, it makes entries in a whole series of indexes. This is all to the good, but it can be maddening.

I've been taught that when you do creative writing on a computer, the first rule is "Save Early And Often." There could be a power failure. Some fiend could pull the power cord. The computer could ingest a moth. *Anything* can happen, and unless you've saved that text from memory to disk, when something does happen, that text is *gone*.

The obvious way to save a file in Valdocs is to use the Store key, but that takes *forever*, after which you're in an empty buffer. You have to reload your file in order to continue working on it. It took me much more than a minute to save a one-page memo, then retrieve it to continue working. When you consider that I'm likely to save a long article such as this one 10 times an hour, and that it would take more than 2 minutes for each save, you can see I just can't do that.

There's another way to save your work: press the Copy Disk key, wait about 15 seconds, and press the Undo key. This stores your work in a temporary workfile that will automatically be accessed the next time you turn the machine on—a neat feature, and certainly a guard against power failures.

The trouble is that it hasn't made any backup file. If you want a backup file, you have to use the Store system. You'd also have to use a different file name.

When you do a save with Wordstar, WRITE, Magic Wand, and most other editors I'm familiar with, certain safe-



The DS120 Terminal Controller makes your LA36 perform like a DECwriter® III.

The Datasouth DS120 gives your DECwriter® II the high speed printing and versatile performance features of the DECwriter® III at only a fraction of the cost. The DS120 is a plug compatible replacement for your LA36 logic board which can be installed in minutes. Standard features include:

- 165 cps bidirectional printing
- Horizontal & Vertical Tabs
- Page Length Selection
- 110-4800 baud operation
- 1000 character print buffer
- X-on, X-off protocol
- Self Test
- RS232 interface
- 20 mA Current Loop interface
- Top of Form
- Adjustable Margins
- Double wide characters
- Parity selection
- Optional APL character set

Over 5,000 DS120 units are now being used by customers ranging from the Fortune 500 to personal computing enthusiasts. In numerous installations, entire networks of terminals have been upgraded to take advantage of today's higher speed data communications services. LSI microprocessor electronics and strict quality control ensure dependable performance for years to come. When service is required, we will respond promptly and effectively. Best of all, we can deliver immediately through our nationwide network of distributors. Just give us a call for all the details.

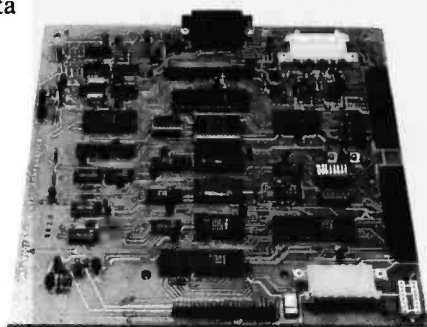

datasouth computer corporation

4216 Stuart Andrew Blvd. • Charlotte, North Carolina 28210 • 704/523-8500

INTRODUCING BELL'S LATEST WAY TO DO BUSINESS WORLDWIDE

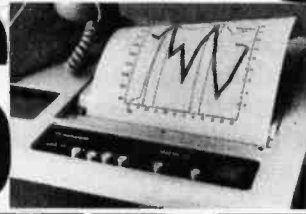

Alternate Voice/Data Private Line.

Voice communication and data transmission in an international telephone connection dedicated to your use only. That's the latest service from your most complete international telecommunications source.

No one gives you more ways to do business worldwide. Dedicated lines. Facsimile, data and voice transmission. And no one gives you Bell reliability. Now we're

going all out to give you a competitive edge. In price. In service. In technological innovation. Call on us whenever international telecommunications can answer your needs.

For more information about Bell's Alternate Voice/Data Private Line Service, contact your Bell Account Executive or call **1 800 821-7979**.



Bell System

Another reason the world is sold on Bell.

ty measures happen. Assume you save your text as FOOFILE.TXT. If you've previously saved that file, the disk will contain a file named FOOFILE.BAK (or .BAC). Now you save again. The system saves your file as FOOFILE.\$\$\$ (or some other temporary name), and only after a successful save and verify does it erase FOOFILE.BAK, rename the old .TXT file to .BAK, and name the new file .TXT. If there's some disaster (power failure, really screwed-up sector on the disk, whatever) during the save, you've still got copies of your work.

Valdocs doesn't do that. If you use the Copy-Undo save, or if you Store and don't give the file a new name, it writes over your only previous copy of the file: in other words, it bets all that it will be successful.

I'm not that confident. Alas, though, in order to have backup copies, I'd have to use Store, and that's just too slow to tolerate.

Joyce Lynn, the very friendly voice of Epson's hot line, tells me Rising Star is working on the problem and

should have some new and faster software by next fall. Indeed, every time I pointed out problems in the Valdocs software, I was told that they'd fix it; that this is an evolving program, and when they get all the problems fixed, they'll send the revised system to everyone who bought the old. I believe that, too; but I do think prospective customers ought to be warned that they're part of a development process.

There's a second problem: Valdocs comes with the "TPM" operating system. Roger Amidon, systems group manager for Rising Star (which produced the software for the Epson), has told me many times that (1) TPM is better than CP/M, and (2) for all practical purposes you use TPM exactly the same as CP/M.

The first statement may be true, but I cannot agree with the second. As an example, TPM doesn't have the CP/M STAT program to allow you to set the output port as TTY:, nor does "ZPIP" allow PIP FILENAME=TTY: (or vice versa) for file transfer. I'm

told that TPM has a highly efficient batch processing system that's much more useful than CP/M's SUBMIT, and there are other excellent features—but I'm also told that the TPM user documents will be available Real Soon Now. Thus, fair warning: if you buy the Epson Valdocs package, check to see that you're getting all the documents you need, including one on the TPM operating system, or be prepared to work entirely within the Valdocs editor environment without ever exiting it.

I had some real problems using Valdocs. Chris Rutkowski told me that was because I was too sophisticated; this is intended for rank beginners. [Editor's Note: See the correspondence between Rutkowski and Pournelle on page 442.] Fine. As an experiment, I put the QX-10 and Valdocs documents on John Carr's desk and hid his Selectric. John is an associate editor on science-fiction anthologies; he doesn't normally use computers.

At first John liked it a lot, and he

CompuPro

8 and/or 16 Bits.

A CompuPro Systems Center is much more than a computer store: It is the first place to look for business, scientific, and industrial computing solutions. When you're ready for professional level, state-of-the-art microcomputing, turn to the professionals listed below . . . they're ready for you.

ARIZONA

Scottsdale
S-100
(800) 528-3138

CALIFORNIA

Bakersfield
Creative Computing Services
(805) 325-9877

Berkley
Track Computer Center
(415) 845-6366

Burlingame
Mentzer Computer Systems
(415) 340-9363

Canyon Country
Creative Computing Services
(805) 251-9877

Carmichael
Logic Systems
(916) 971-3133

Chatsworth
Priority One Electronics
(213) 709-5464

Hayward
Byte Shop of Hayward
(415) 886-4732

Irvine
Priority One Electronics
(714) 660-1411

Los Angeles
American Computers & Engineers
(213) 477-6751

Gifford Computer Systems
(213) 477-3921

Mountain View
ACC
(415) 969-4969

Oakland
Track Computer Center
(415) 444-8725

Pacific Palisades
System Interface Consultants
(213) 454-2100

Pasadena
Omni Unlimited
(213) 795-6664

Petaluma
Advanced Information Mgmt.
(707) 763-7283

Pleasanton
Best Computer Stores
(415) 463-2233

certainly was able to use it right off the bat without reading a lot of documents. After a while, though, problems showed up.

Item: the QX-10 uses a single Z80 as both CPU (central processing unit, or brain) and as the manager for putting the text onto the memory-mapped screen. That's not inherently impossible, of course; Zeke II, the machine I'm writing this on, does precisely that. However, the Valdocs software just overwhelms the Z80, so that what goes on the screen lags what you type by an appreciable amount. This is very annoying, and you don't really get used to it. John said he hoped he'd never have to type a long document with that.

Second, Valdocs doesn't have any way to print except to store it first. That means that it takes a minimum of two minutes to address an envelope. The Valdocs documents describe a "screen dump" feature that will print whatever you see on the screen. When we tried that with an address, however, it locked up the

machine so that we had to reset it to get out; double plus ungood.

Third, Valdocs doesn't know how to print one sheet at a time. It's apparently fine for continuous fanfold, but if you want to use letterhead, you've got a problem. The program won't accept variable top and bottom margins: you have to set the bottom margin for the whole document, and of course the proper margin for the first page of letterhead is not the same as for the second and following sheets.

Finally, it's just plain slow all around. Example: I wanted to create 64 Valdocs files to check whether the directory could handle more; I created a three-line test file and started in. Save. Restore. Save. Restore. I was watching *The Pajama Game*, but the movie ran out before I was done: 2 hours and 20 minutes.

Getting from the beginning to the end of a six-page document takes 15 seconds. Deleting the first three pages of the same document takes 30 seconds. Killing unwanted files takes

nearly a minute each.

In my judgment, the Valdocs system is noble in objective, but I don't think they'll ever get it to work reliably at an acceptable speed on a Z80. If Valdocs were available for something like the Eagle 1600, with its hard disk and 16-bit processor, it might be a different story.

There's also some confusion on the philosophy of Valdocs. On the one hand, Epson tried to make everything similar to what you'd experience if you were using a typewriter. Alas, then it put in a number of undocumented features, some excellent, but none of which you can reason your way to. Then, finally, Epson added other (definitely useful) features that assume you have read and absorbed all the documents and are reasonably familiar with computers. A lot of this looks as if it were designed by a committee that doesn't meet very often.

Valdocs is evolving. Some of the problems may be fixed by the time you read this. I hope so; but I have

Spoken Here...

San Francisco

Gifford Computer Systems
(415) 391-4570

San Leandro

Gifford Computer Systems
(415) 895-0798

San Rafael

Computer House
(415) 453-0865

Santa Barbara

Data Bank
(805) 962-8489

Santa Maria

Data Bank
(805) 922-1333

Santa Rosa

Matrix Computers
(707) 542-0571

Sunnyvale

Pragmatic Designs, Inc.
(408) 736-8670

FLORIDA

Brandon

Micro Computer Technology
(813) 685-7659

HAWAII

Kahulul Maui

Capacity Plus Computers
(808) 877-3496

ILLINOIS

Athens

Computers Plus
(217) 636-8491

La Grange Park

Small Business Systems, Inc.
(312) 579-3311

Skokie

Lillipute Computer Mart, Inc.
(312) 674-1383

INDIANA

Terre Haute

General Software, Inc.
(812) 234-9421

MARYLAND

Bethesda

JR Systems
(301) 657-3598

MASSACHUSETTS

Boston

New England Electronic Exch.
(617) 491-3000

Chestnut Hill

Key Micro Systems
(617) 738-7306

(Please turn the page)

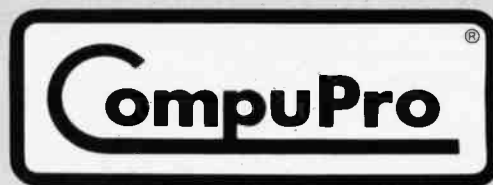

CompuPro, a **GODBOUT** COMPANY

3506 Breakwater Court, Hayward, CA 94545

to review what I have, not what I'm told is coming.

Alas, too, I think Epson is up against a fundamental limit. Apple's Lisa software pushes the Motorola 68000 chip right up to its limits, which is why Lisa is so slow. In my judgment, Valdocs has pushed the Zilog Z80 chip *past* its limits; I'd love to be proved wrong, but I don't think Valdocs will ever run properly until something like the 8086 or 68000 is used.

The Epson FX-80 Printer

The FX-80 is Epson's newest top-of-the-line dot-matrix printer. It has very good print quality. With proper software to drive it in the "letter-quality" mode, it would certainly be adequate to produce submission-quality manuscripts and correspondence.

This is a really nifty printer; we had it working with the QX-10 a couple of weeks ago, using it to print graphs we made with the Valdocs graph-construction program. (The graph program is very similar to the CHAR-

TON graph program that comes with the Otrona.) The FX-80 made neat graphs of all kinds: pie, bar, wavy lines, and scattergram.

There's one feature that's also a problem. The feature is "last form access," meaning that the FX-80 is designed to let you remove the last page printed without wasting a sheet. The problem is that the design that allows this makes it very difficult to get the paper into the machine; in fact, I couldn't do it until a nice young lady at the Epson booth at CCS showed me how. (The secret is to ignore the instructions in the FX-80 manual.) Once you get the fanfold paper in, the printer works fine.

The FX-80 is not well designed for feeding in a sheet at a time. With proper text-editor software you could use letterhead paper, but as Valdocs is written at present, that's very difficult.

In fact, we had so much difficulty with paper feed that we finally hooked up the MPI Model 99G printer to the QX-10. John Matlock of

The Printer People sent me a cable to allow that; he's interested in a speed comparison between the 99G and the FX-80. I haven't done that test yet, but the 99G certainly prints both letters and graphs with quality at least equal to the FX-80. It also has a normal external tractor that lets you feed in the paper without problems, and it works just fine. Full comparison another time.

Comparing Editors

One of the panels at the West Coast Computer Faire was devoted to text editors and word processing. I'd intended to go to it, but I got trapped in something conflicting. It was conducted by Arthur Naiman. I met him for about one minute before his panel. I'm sorry I missed the panel, because I'm told it was very good. I believe that, because last week I got a copy of Arthur Naiman's new book, *Word Processing Buyer's Guide*, and that's *excellent*.

I would be proud to have written

Text continued on page 446

...And Here.

NEW YORK

Deer Park
Datapro Systems, Inc.
(516) 595-1311

Staten Island
John D. Owens Associates, Inc.
(212) 448-6283

NORTH CAROLINA

Greensboro
General Semantics, Inc.
(919) 288-1117

OREGON

Portland
Microwest Computer Products
(503) 238-6274

RHODE ISLAND

Coventry
Key Micro Systems
(401) 828-7270

TEXAS

Houston
Gifford Computer Systems
(713) 877-1212

WISCONSIN

Greenfield
Byte Shop of Milwaukee
(414) 281-7004

CANADA

Burnaby, British Columbia
Dynacomp Business Computers Ltd.
(604) 299-3747

Coquitlam, British Columbia

CSC System Center Ltd.
(604) 941-0622

THE PHILIPPINES

Quezon City
Corona International Inc.
78-34-71

UNITED KINGDOM

Swansea
Comcen Technology Ltd.
(0792) 796000

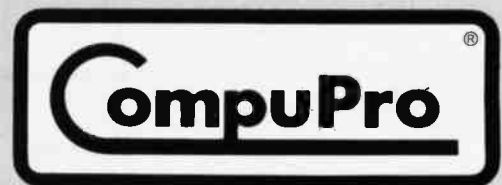

CompuPro, a **GODBOUT** COMPANY
3506 Breakwater Court, Hayward, CA 94545

We take on Ted Turner

DHL, #1 Worldwide Courier Express, now makes time-critical deliveries overnight throughout the U.S.

It takes a special kind of person to take on all challengers and come out ahead. A person like Ted Turner, who not only successfully defended the America's Cup but who indelibly changed the picture of American television with the first 24-hour news service on his innovative Cable News Network.

In today's world, speed of information is vital. "You not only have to be smarter than the next guy, you have to be faster," says Turner.

That's why DHL takes on Ted Turner.

"For overnight delivery of time-critical documents and packages anywhere in the U.S.," says Turner, "they're the next best thing to taking it there yourself."

Because, like Turner's superstation, DHL has incredible reach.

30,000 locations.

Service to 97% of the "Fortune 500."

More on-time deliveries to more places around the world than any other express courier.

And DHL makes sure clients like Ted Turner stay ahead with state-of-the-art technology.

DHL uses 727s, Learjets, helicopters and its

large fleet of trucks

to speed urgent documents

and packages on their way,

all across America.

"The only thing they can't deliver," says Turner, "is a pennant for my Atlanta Braves."

For information, call your local office of DHL Worldwide Courier Express.

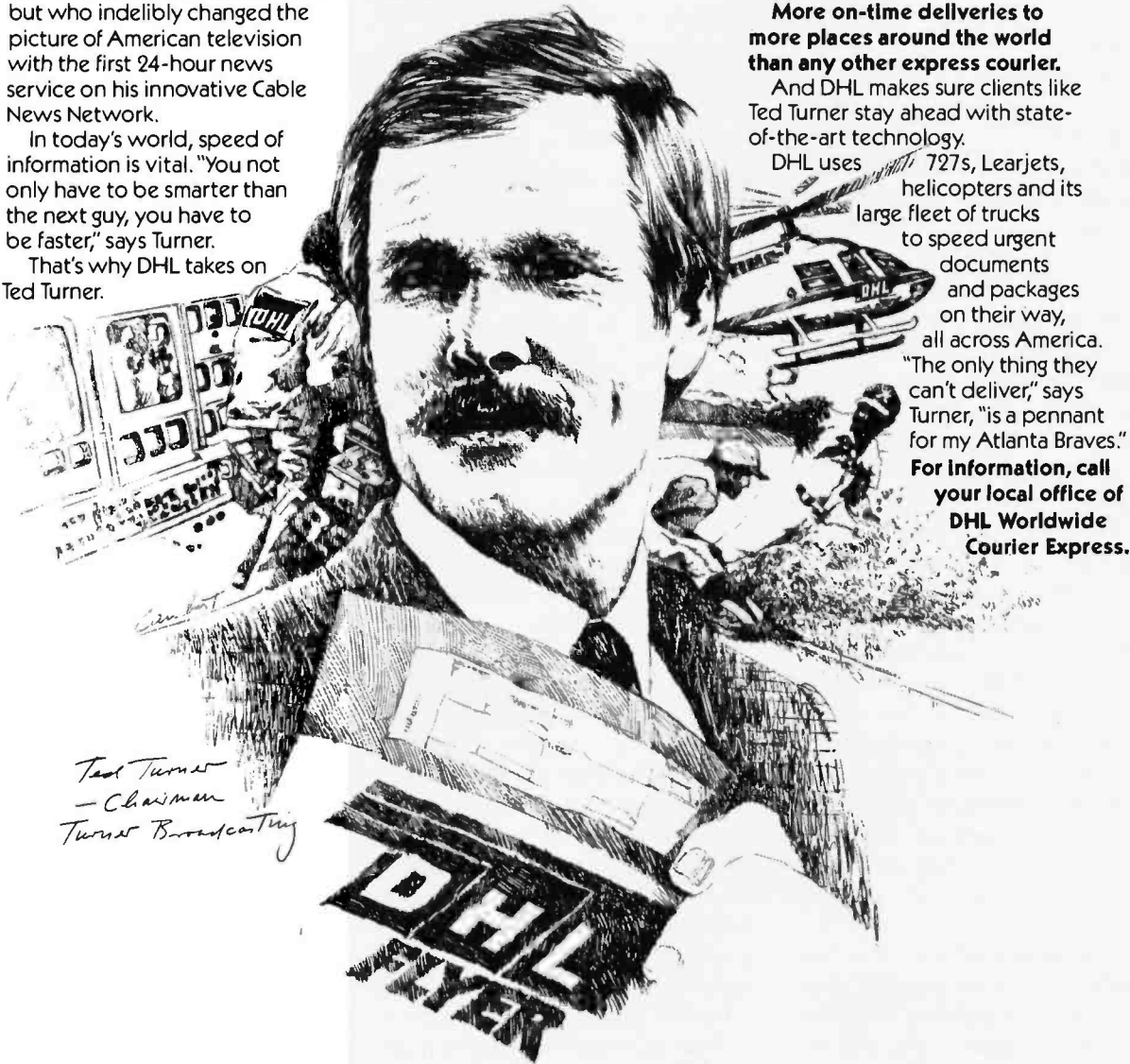

*Ted Turner
- Chairman
Turner Broadcasting*

NEXT BEST THING TO TAKING IT THERE YOURSELF.

Epilogue: A Look at Valdocs

As you know if you read Jerry's column, our intrepid user had some problems with Valdocs. Searching for an explanation, he called Chris Rutkowski, president of Rising Star Industries, with his comments and sent Rutkowski a draft version of this month's User's Column. What follows is the exchange that ensued between Rutkowski and Pournelle.

Dear Jerry,

Upon reflection, it seems that your criticisms of Valdocs are primarily related to the difficulty of adapting the Valdocs environment into a preexisting CP/M environment. That is, you have a number of computers, a large body of software, and far more peripherals than anyone would call average. Add to this your data and text files, and clearly, you are pretty well established.

Taking a QX-10 with Valdocs and integrating it into all of this is not a trivial task. But then, no one ever said it was, or that Valdocs would make that job any easier. This is not a function of Valdocs, which is a user environment; it is a function of the operating system, and in this regard, TPM is no different from CP/M, Unix, or any other. Without complete and proper documentation, the user will find it impossible to meld the system into a preexisting complex. And this documentation is not included with the first release of the machine.

But before you criticize this too strongly, please remember two things. First, the primary target for the Valdocs system is the person who will use it as a stand-alone system. For this user, the problems you encountered are of no consequence, for now at least. Second,

we are taking action to ensure that the documentation required to fully integrate the QX-10/Valdocs system with other environments is provided. This includes

- a TPM primer, which is being written by the author of a popular CP/M primer
- a plug-in 8-inch and 5¼-inch disk-controller card that will facilitate the easy transfer of software between the Valdocs system and any CP/M system
- a Valdocs technical manual that thoroughly documents the Val-

"It boils down to this: Valdocs is not well suited as a hacker's environment, nor was it ever intended to be."

docs database filer, the bit-mapped screen drivers, etc. (This section will be of interest only to those who wish to write software specifically for the Valdocs environment.) These should be available by August. Thus even the inherently difficult job that you are attempting will be feasible.

I disagree that the Valdocs system was "designed by geniuses for use by idiots," unless you define idiot as "someone who neither knows nor cares about how a computer functions internally—who only wants to use the machine as a tool." I call that person normal.

Your statement that our philosophy is confused is both inaccurate and inappropriate. As long as the user remains in the Valdocs environment, things are simple

and straightforward, although capable of quite sophisticated and comprehensive interactions. But as soon as the user departs that environment, he's on his own, just as he's on his own using any other operating system/computer combination. The current expert-level settings are arranged so that at the novice levels, even the possibility of departing the Valdocs environment is precluded. Thus the novice does not need to understand the operating system to enjoy the user environment.

Your observations about the slowness of the Epson disks is the result of comparing apples and oranges. A Store from within Valdocs is not a simple file save. The Indx program, which is invoked by Store, is a complex cross-indexing database filing system that has little in common with that of any other word processor on the market. When Store is invoked, numerous disk operations have to take place to update the database (in a hard-disk environment with a large index, this could amount to dozens of operations). This can, quite logically, take a minute or more.

Obviously, using Store as a measure of disk speed is not likely to produce meaningful results. While we are not using track buffering or cache buffering to enhance disk speed, the Epson disks are otherwise quite competitive with any others on the market. We can perform a more meaningful test by exiting from the editor to the menu by pressing the Menu key. From the menu we can chain to other Valdocs modules without having to close any temporary files or the like. When chaining from the menu to other modules, the length of time

from the keypress to the blanking of the screen is the length of time it took the system to load the program off disk and start execution. Press one of the other function keys, such as MAIL, SCHD, or DRAW. The results are interesting: Schd, which is about 52K bytes in length, takes about 13 seconds to load. Mail, at 37K bytes, takes less than 10 seconds. Frankly, while no hard disks need feel threatened, these times are quite respectable and are typical of what a user would expect to experience with any CP/M-like system using 5¼-inch drives.

As you observed, the Store mechanism is too slow to be useful for a Save. As a result, we created a separate mechanism to execute Saves. This mechanism has been in every version of Valdocs you have ever seen. (Note that when you press CONTROL Q, a new menu appears in the editor. This menu allows normal CP/M such as Saves, Retrieves, Directories, etc. However, we felt that such operating system operations were inappropriate for an elegant Save mechanism.) The actual Save mechanism is documented on page 2-24 or 2-25 of the Valdocs manual. In short, with only two keystrokes, you can save any file. The length of time to execute this save is only 15 seconds or so for files of any length.

While chaining from the editor to any other function, all editor work files are closed (which is the mechanism of a Save). This assures the user that his work is safe and also provides some unique capabilities. For example, at the end of a workday the user can chain out to menu and then power down. When he reboots the system in the morning, he'll find that

Valdocs will sign on with his file in place, all tabs and margins correctly set, and his cursor exactly where he left it in the document. Additionally, this ensures that simply using the various functions of Valdocs continually saves the user's work. Thus the need to knowingly perform a discrete Save operation is dramatically reduced.

This Save mechanism is not intuitive, but, then, the necessity to do Saves at all is in no way intuitive. So, the need to save your work and the procedure for doing it can easily be taught in the same

"The current (May 1983) version of Valdocs is only a starting point. Much remains to be done to add in every possible feature."

place at the same time. (In developing Valdocs and HASCI, we have found that there are perhaps a half-dozen things that a prospective user must learn.) By August, Save will have been reduced to a single keystroke.

Our reasons for using TPM are many and valid. TPM has a Chain function, without which Valdocs would have been nearly impossible. It also supports a multibank system as well as up to 255 user areas and allows cross-user operations (vastly superior to CP/M's user constructs). By August, TPM will have hashed directories and numerous other improvements. Our reason for choosing TPM was that in 1982, TPM already supported many of the features now being introduced in version 3.0 of

CP/M. TPM is compatible with both 1.4 and 2.2 versions of CP/M, but that doesn't mean that their user interfaces are identical. (Most common commands—DIR, ERA, PIP, SAVE, REM, etc.—however, can be used identically, even though they possess numerous enhancements.) It means that they are functionally equivalent. The goal of Computer Design Labs (authors of TPM) was, of course, to have any CP/M-compatible software execute properly within the TPM environment. This has been no easy task.

CP/M was written in 8080 code, and more than one developer using CP/M on a Z80 took advantage of this to do some very strange things with the additional Z80 registers. Furthermore, more than one aspect of CP/M is documented quite poorly, complicating the task. As of this writing, we know of no CP/M program that does not run correctly under TPM. If any are found, the folks at CDL will be delighted to remedy the situation.

Your difficulties are in fact a function of your highly developed computer literacy: through the traditional school of hard knocks you've learned a lot of painful lessons about the need for documentation, the dangers of systems, and so on, lessons that simply don't apply in the Valdocs environment. It boils down to this: Valdocs is not well suited as a hacker's environment, nor was it ever intended to be. However, your statement that Valdocs is not suitable for professional writing tasks is in disagreement with the findings of our other 30 or so test sites, which include a great many professional wordsmiths.

The current (May 1983) version

of Valdocs is only a starting point. Much remains to be done to add in every possible feature. But our stated goal is that "90 percent of the potential users of Valdocs will never need any software not provided directly by the Valdocs environment." It is a tall order—and one which we expect to have largely accomplished within a year. In the meantime, most users will find Valdocs very satisfactory for most applications. Users who have very specific requirements in mind are, as always, well advised to check carefully before assuming that Valdocs will or will not suit their purposes.

Chris Rutkowski

Dear Chris,

I really think you have misunderstood, and perhaps my readers may, so I'll try to be more clear.

Agreed: integrating the QX-10 into my system here was what I first had in mind. I'd still like to try it as a *small computer* using one or another text editor. However, I do not know what terminal it emulates, and I still have no CP/M for it. TPM may be excellent, but I would have to write an assembly-language program to transfer files, as far as I can see. The package I got with the last software delivery said "Your QX-10 package may not be complete. The following items may be on backorder: CP/M Diskette, CP/M+ Manual."

In any event, I put the system in the other room and put the Selectric away. I paid John Carr's time to have him learn the system and handed him the manuals. John, an associate editor on science fiction anthologies, is totally unfamiliar with CP/M or any other operating system. His computer experience in the past has been confined to using a text editor after someone loaded the editor for him. Thus this seemed a fair test.

When the system crashed (after the directory was full) completely without warning, it didn't make John feel better about the QX-10.

I should, I suppose, have shown him how to cancel files (or he should have done it, from reading the manual). Most of the files in the system were nothing more than addresses. That's one of the most serious problems: WE COULD NOT MAKE IT PRINT WITHOUT SAVING THE FILE FIRST.

We tried the Screen Dump instructions, and they don't save the file. What are we supposed to do? Save the address for the envelope, using Store—which takes a fairly long time—then cancel that file, which takes more time? True, we often use window envelopes, but one of the major difficulties we had was with the print system using letterhead and single sheets

"As I understand it, until you Store the document, you are writing over your last Save. That's not what I would call safety."

of paper. I'm trying it now, with the disk that came with the documents, presumably what is for sale to the public. We'll see what happens.

Incidentally, now I'll try the setup program and set the clock and such.

I changed the printer to FX-80. It was already set to the expert level. I fear I can make no sense of the input command; if there's a way to set things to TTY:, I cannot find out how that is done. Otherwise, as instructions dictated, I did not change anything. The clock, incidentally, is very accurate and has been running on time within a minute since the machine arrived.

Now for your points. I will wait for the TPM Primer. My remarks are pretty well confined to the experience within the Valdocs sys-

tem, and we'll look at the Epson as a small computer independent of that when we have either of the TPM documents (I have one set, but they didn't explain how to transfer files. Unfortunately, the Osborne is not here just now; it reads a lot of formats, and I could transfer files from it to the Epson, etc., but that just doesn't seem reasonable).

I anxiously await the new controller that allows reading and formatting (I presume it will either offer a variety of disk formats or will write to previously formatted disks in the format they are in. I expect that it can read from one format and write to another, as the Lobo does).

I'd love a look at the Valdocs technical manual, but I don't really need it for what I'm trying to do now.

I still want Valdocs to work very much. I would like to have the whole system, with the database and address book and all the other features. However, until we can easily and conveniently write letters and do the general work of the office here, the other features aren't relevant.

It is certainly a drawback not to be able to change bottom and top page margins within a document. I don't think I can do that. I will try again. . . .No. When I change the bottom margin, wherever I am, I find myself at the top of the page again. This means that the system is nearly useless for letters on letterhead and not very good for other documents because you must format your text all at once. I have just tried the Size key, but I don't think it does anything.

More thoughts. For those used to computers, the type "drags" across the screen and cursor motion is very slow. I agree that's a function of what you're used to, and I am, on purpose, accustomed to the fastest and best word processing system.

Incidentally, the hyphen feature of Valdocs is a fatal error. Valdocs

broke my line at the hyphen in word-processing. I had not intended the word to be broken there. Most authors do not want the machine to decide things like that for them, and I always send my manuscripts with no hyphens at all unless I intended them. I never leave a hyphen at the end of a line because that would be ambiguous to a typesetter or copy editor.

I will now try to Save using the instructions in the manual. I used Copy Disk, waited for a new prompt, and then pressed UNDO. Saving these three pages took 21.19 seconds, which I agree is reasonable. But it is also counterintuitive and differs from the philosophy we have up to now been led to expect. Moreover, I do not believe this makes a backup copy. As I understand it, until you Store the document, you are writing over your last Save. That's not what I would call safety. I am probably a fanatic on the subject of document integrity, but I am not likely to change, and neither are most authors.

I'm willing to believe you about TPM, but the fact is that I have been unable to make TPM do what CP/M's Stat program does. I have also been unable to figure out how to do the equivalent with whatever programs TPM employs. It may be a wonderful operating system, optimized and all that, but I don't have what it takes to learn it.

I would make the following improvements in Valdocs:

1. Have a Kill program that lets you run down a list of files and mark each D for Delete; then when you execute the program, it gets rid of them.
2. Make it possible to print without Storing the file. Sometimes we only want a short letter; we have no intention of keeping a copy, and we're interested in getting the work out the door. Same for addressing envelopes;

we have to keep a typewriter around to make mailing labels and envelopes.

3. Allow imbedded format commands of some kind so that, for example, we could change the bottom margin on page 2.
4. Have a Setup file that you can put your favorite defaults into. Tabs, for example; why must I set them for each document?
5. Naturally, you must have a way to deal with John's data disk disaster. Was that an older copy, or does it happen on all? I may test this tonight. Try to overfill the directory, and overfill the disk, and see what happens with the distribution software. First we will test the system to

"I agree that users don't need to know everything that's going on in the system, but they should be able to do things quickly and easily."

see how well we can print letters. I have fooled the FX-80 into believing there is paper by inserting a second sheet behind the first, but that's a pretty lousy way to have to proceed.

6. I'd think, then, that mating the system with the printer would be useful. There should also be an Install program that would let you use Valdocs with the RS-232C port so that it could be used with Diablo and NEC Spinwriter printers, although I agree that these new Epson printers produce high-quality work.
7. The Shift down-arrow doesn't really move to next visible page, but up a few lines. Perhaps you need a Multiplier key, as in EMACS, MINCE, and Wordmaster; in those ^W multiplies the next command by a factor of

4. Multiple uses multiply in cascade.

As to "designed by geniuses for execution by idiots," I agree that users don't need to know everything that's going on in the system, but they should be able to do things quickly and easily.

Anyway, there's a lot to like about Valdocs, and it could be terrific if implemented on a faster machine with a hard disk. Also, when finished for the Epson, I agree that it could be about as good as any system I know of, especially for the price.

I have to quit now. We'll see how the printing goes. [Editor's note: At this point in the letter, the sentences are printed diagonally across the page. After some investigation, Jerry discovered that if you insert the paper into the printer crookedly and then try to fix it, the printer begins printing. The reason for this is that the software sensor that determines whether the paper is indeed in the printer can be tripped before paper is located correctly under the print head. Jerry's letter continues now after several lines that illustrate the problem better than this description. . . . P. C.]

If you do not tell the printer to stop between pages, it does a formfeed when it starts, though you didn't tell it to, so don't try that with a single sheet in the machine.

The slowness of this screen is about to drive me crazy. I can type about four words ahead of the screen, sometimes, and sometimes not; it's not obvious what the relationship is. But I could live with all that. What I can't live with is the inability to write letters.

It is now 11:00, and I began this at 8:50. That's a lot of time for a 6-page letter. It took one minute and two seconds to Store. We'll do that again, and retrieve it. I have been an hour and a half writing this. I would have done far better with a Selectric. Sigh.

Jerry Pournelle■

this book. It's clear, objective, and damned thorough. It even has a review of WRITE, the text editor I use; Naiman read one of my articles and managed to get hold of Tony Pietsch, WRITE's author, and buy not only WRITE, but a computer modeled after Ezekial.

I gather from Naiman's book that, like me, he has just about every word-processing and text-editing program in existence. He even wrote the Sybex *Introduction to Word Star*. (Interestingly, Naiman used WRITE

to write it.)

Naiman uses an interesting point system to evaluate word-processing programs; thus you can see *exactly* why he rates the various programs the way he does. This book discusses just about every text editor I know of, plus a lot I had never heard of before reading his book. Anyone contemplating the purchase of a text editor or word processor should run, not walk, to the store and get this book before spending a single dime on word-processing software.

The Z-29

When the new Zenith Z-29 keyboard arrived, I was about to go off to Bellingham; I wouldn't be able to do anything with it for at least a week. As it happens, the night before the Z-29 arrived Chuck McMannis' home terminal had died. Chuck is our new research assistant. The solution, therefore, was obvious, and Chuck took the Z-29 home with him.

When I came back I found he had made his other boss (the one who pays him a living wage) buy a Z-29 for their minicomputer. Chuck thinks the Z-29 is the best thing he's seen for the money. The following is largely drawn from his report.

The Z-29 (H-29 in kit form) is a second-generation machine. It fixes most of the identified bugs that existed in the Z-19 and adds a detachable keyboard as well. Not only that, it has been sculpted to make it more like a Selectric. It has excellent feel. Some find it a bit "thick" for sitting on a desk although perfect for putting on your lap; I haven't noticed any problems at all.

If your system can use a Z-19, you can plug in the Z-29 and run. In addition, the Z-29 can emulate a Hazeltine 1500 and a Lear Siegler ADM 3A. Best of all, from Tony Pietsch's viewpoint, it has a full ANSI (American National Standards Institute) mode. This is important because all the big computer companies are moving toward the ANSI Standard communications mode.

I'm not entirely happy with the key layout. The arrow keys are put over for right-hand use; they're grouped above the Return key. I'd prefer a small separate left-hand pad of arrows with Home in the middle. This is a matter of taste and what one is used to, of course, and it won't take long to get used to the Z-29 layout.

The character set is aesthetically pleasing. There are several new attributes: underline, blink, and half-intensity. The screen is 24 by 80 with a twenty-fifth status line. The twenty-fifth line accesses a built-in real-time clock. An alternate character set is included.

It does have problems. They work hell out of the 8051 chip in there, and

10 reasons why you should call DataSource™ for micro software and hardware...

- 1. Software and Hardware for all Popular Microcomputers.** We carry software in all popular formats and operating systems including PC-DOS, MS-DOS, CP/M-86 and CP/M-80. Always the current versions in stock.
- 2. Competitive Prices** Our volume enables us to offer you prices which are consistently competitive. Compare for yourself, then call us toll-free 800-328-2260.
- 3. Express Delivery** Time is money and we at DataSource understand that. Your order will be processed and shipped within 24 hours for all products in stock.
- 4. Discount Structures** We offer significant discounts to any individual, organization or user's group purchasing in quantity.
- 5. Key Account Program** For corporations and institutions, we offer a comprehensive program: volume discounts, complete maintenance packages, specially staffed technical support, a sales team experienced in micro applications, and several financing options.
- 6. Risk-Free Software** We stand behind every product we sell. All items are fully documented, backed by manufacturer's warranties, and are guaranteed by DataSource to be in perfect working condition.
- 7. Toll-Free Technical Support** We service what we sell. Our customers have direct access to our technical staff on a toll-free basis. 800-328-2260.
- 8. National Maintenance Network.** We offer a variety of maintenance agreements tailored to the specific hardware items you select. Call for more information.
- 9. Flexible Payment Options** We accept most major credit cards, checks, and money orders, as well as purchase orders from approved corporate accounts.
- 10. Proven Track Record.** Join our growing list of customers which include many Fortune 500 companies, major educational institutions and government entities.

Here's a small sampling of products available now from DataSource™ (If you don't see what you need, just call us at the number below.)

Data Base Management					
Data Design - Insoft	*CALL*				
dBase II - Ashton Tate	\$449.00				
Condor III - Condor	495.00				
Easy Filer - IUS	275.00				
Vistafile - Visicorp	189.00				
Tim III - Innovative Software	325.00				
Intostar - Micropro	297.00				
PFS: File - Software Publishing	99.00				
PFS: Report - Software Publishing	95.00				
Quickcode - Fox & Geller	215.00				
DB Plus - Humansoft	99.00				
Knowledge Man - MDBS	350.00				
Versa Form - Applied Software Tech.	209.00				
Spreadsheets/Finance					
Supercalc - Sorcim	125.00				
Supercalc 2 - Sorcim	169.00				
Viscalc - Visicorp	189.00				
Multiplan - Microsoft	195.00				
Financial Planner - Ashton Tate	*CALL*				
Bottom Line Strategist - Ashton Tate	*CALL*				
Word Processing					
Wordstar - Micropro	289.00				
Wordstar/Mailmerge - Micropro	375.00				
Spellbinder - Lexisoft	295.00				
The Final Word - Mark of the Unicorn	239.00				
Easy Writer II - IUS	239.00				
VolExWriter - Lifetree	125.00				
Superwriter - Sorcim	179.00				
Multimate - Software Systems	359.00				
Visiword - Visicorp	*CALL*				
Peachtree 5000 - Peachtree	285.00				
The Word Plus - Oasis	125.00				
Grammatik - Aspen	60.00				
Punctuation & Style - Oasis	99.00				
Random House					
Thesaurus - Dictionaries	115.00				
Graphics					
Chartman - Graphic Software	225.00				
PFS: Graph - Software Publishing	105.00				
dGraph - Fox & Geller	215.00				
Visitend/Plot - Visicorp	225.00				
Fast Graph - Innovative Software	199.00				
Graphwriter - Graphic Communication	325.00				
Languages/os					
CP/M 86 - Digital Research	50.00				
Basic Compiler (IBM PC) - Microsoft	298.00				
Pascal MT+86 (IBM PC) - Digital Res.	285.00				
Fortran (IBM PC) - Supersoft	325.00				
Communications					
Crosstalk - Microstuf	145.00				
Intercom II - Hayes	85.00				
PC/Intercom - Mark of the Unicorn	75.00				
Emulink 3270 emulation - Micro Link	695.00				
Miscellaneous					
The Home Accountant - Continental	99.00				
Personal Investor - PBL	105.00				
Superfile - FTI	125.00				
Statpak - NW Analytical	395.00				
Milestone 86 - Organic Software	245.00				
Easy Business Accounting Modules - IUS	450.00 ea.				
FCM - Continental	90.00				
Financier Personal Series - Financier	130.00				
T/! Solver - Software Arts	*CALL*				
Hardware					
Epson FX80	595.00				
Okidata 92-A	575.00				
C. Itoh 8510 Starwriter	1250.00				
NEC 3550	399.00				
Hayes 300 Smartmodem	1915.00				
Hayes 1200 Smartmodem	220.00				
Hayes 1200B w/Smartcom	525.00				
Quadboard 04 K	*CALL*				
Seattle RAM + 128 K	325.00				
Gorilla Banana	*CALL*				
	219.00				

August Specials from DataSource™

Micropro Professional Pak... Wordstar, Mailmerge, Spellstar, PLUS free Star Index call for only \$425.00
Microsoft Basic Compiler-Osborne \$235.00

Only from DataSource:
PC Utility Pak (Sort Directory & Disk Clean-up) - \$39.00
PC Consulting

FOR MORE INFORMATION CALL TOLL-FREE

1-800-328-2260

IN MINNESOTA, CALL 612-544-3615

New hours: M-F 8-6, Sat. 9-3 CST

Prices reflect a 3 1/2% cash discount and are subject to change without notice. Purchase orders accepted from approved corporate accounts. All orders are shipped UPS. \$3 shipping charge on software items. 2% shipping charge on hardware items.

DATASOURCE

DATASOURCE SYSTEMS MARKETING CORP.

Your source for micro software and hardware™

1660 South Highway 100, Minneapolis, MN 55416



Now your computer can say anything and say it well. Introducing the Votrax Personal Speech System.

Quite articulate.

The unlimited vocabulary Votrax Personal Speech System is the most sophisticated, low cost voice synthesizer available today. Its highly articulate text-to-speech translator lets your computer properly pronounce conversational words at least 95% of the time.

For all those unusual words and proper names, you can define an exception word table and store your own translations. And remember, the entirely self-contained Votrax PS System gets your computer talking without using any valuable computer memory.

Built-in versatility.

Much more than just a voice output device, the Votrax PS System lets you mix either speech and sound effects or speech and music. A programmable master clock and 255 programmable frequencies give you unmatched control of speech and sound effects.

The Votrax PS System offers user expandable ROM for custom applications, user downloadable software capability and sound effects subroutines for easy user programming. Its programmable speech rate provides more natural rhythm, while 16 programmable amplitude levels give you greater control of word emphasis.

Actual size: 12.2" x 4.5" x 2.6"

Friendly to humans.

Designed to look like a printer to your computer, the Votrax PS System is extremely easy to use. It can be used in tandem with your printer without an additional interface card. Both serial and parallel ports come standard, allowing you to connect the Votrax PS System to virtually any computer. Speech, music and sound effects are only a PRINT statement away.

computer instruction with voice textbooks as well as spoken drills and testing. And then, late at night, you can make those adventure games explode.

A quick list.

- Highly articulate Votrax text-to-speech translator.
- 255 programmable frequencies for speech/sound effects.
- 16 amplitude levels.
- Simultaneous speech and sound effects or speech and music.
- 8 octave, 3 note music synthesis.
 - Serial and parallel interface standard.
 - User programmable master clock.
 - User defined exception word table.
 - User programmable speech rate, amplitude and inflection.
 - User expandable ROM for custom applications.
 - User downloadable software capability.
 - 3,500 character input buffer: sub-divisible for a printer buffer.
- Internal speaker and external speaker jack.
- Real time clock and 8 user defined alarms.
- Oral power up and error prompting.
- X-on/X-off and RTS-CTS handshaking.
- Programmable Baud settings (75-9600).
- Interrupt driven Z-80 microprocessor.
- Parallel/Serial interconnect modes.
- Proper number string translation: the number "154" is pronounced "one hundred fifty four".

To order, see your local computer retailer or call toll-free

1-800-521-1350

Michigan residents, please call (313) 588-0341. MasterCard, VISA or personal check accepted. The price is \$395 plus \$4 for delivery. Educational discount available. Add sales tax in Michigan and California.

© VOTRAX 1982

“Listen here”

What to say after “Hello”.

Businesses will appreciate spoken data transmission, narration of graphic displays and unmanned, oral product demonstrations. Spoken verification of data input will make computers much easier for the blind to use. School children can receive comprehensive

Votrax®

The Votrax Personal Speech System is covered by a limited warranty.

Write Votrax for a free copy.

500 Stephenson Highway, Troy, MI 48084

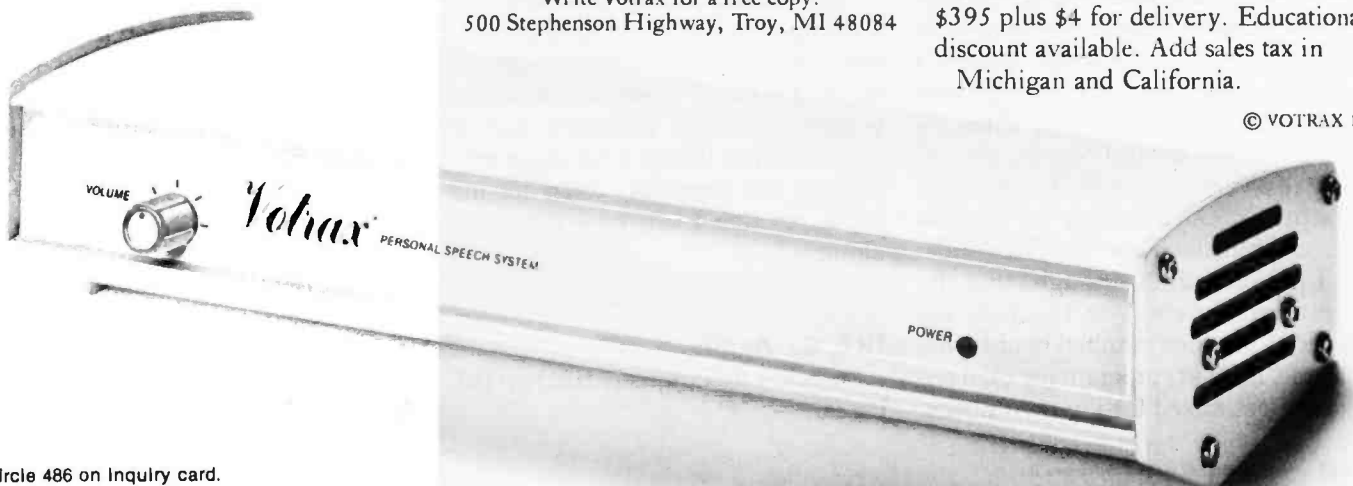

Circle 486 on Inquiry card.

www.americanradiohistory.com

Zenith didn't supply enough memory: the buffer is only 32 characters long, and that can be overrun. I'd have thought with memory so cheap the company would have provided at least 128 characters; 256 would have been better. It did provide an X-ON X-OFF handshake routine (a way to tell the computer "Stop sending! My buffer is full!"), but I hope that one day there'll be an upgrade to add more memory.

For reasons I do not understand, the cable connecting the keyboard plugs in at the *back* of the terminal. Nearly every terminal does this; I can't think why.

The brightness control is a knob on the back of the terminal, neatly placed so that you cannot adjust screen brightness while sitting where you'll look at the screen. Obviously Zenith ought to have made this a software adjust (as with the Otrona).

Note: Steve Ingish of Zenith tells me putting the connection and control on the back saves about \$50 on the terminal's price.

On the plus side, Zenith has provided a software setup menu; no longer must you flip physical switches, then turn the terminal off and back on to change the terminal parameters. Another plus that Ciarcia will like: there's almost no EMI (electromagnetic interference).

Chuck McMannis' final comment is, "If you can find a better terminal, buy it." He has seen nothing he likes better at anywhere near the price.

I tend to be a little more cautious; I want to experiment with the Z-29 for a while. Even so, there's a very good chance that the Z-29 will become the principal terminal for our workhorse machines. Except for that small memory buffer, I've seen little about it that I don't like. Before I make a final judgment, though, the Z-29 will go over to Tony Pietsch's place, where he and Nor Singh will install a version of WRITE optimized for the Z-29 and making use of all its special-function keys. *Then* I'll decide.

I have to admit, though, that the only serious rivals to the Z-29 are special-purpose terminal boards that let me, in effect, program my own terminal optimized for my own needs.

I have a couple of those, and I'll report on them in another column. Meanwhile, I like the Z-29 quite a lot.

Oh, It's Easy To Get It Running . . .

In Ithaca I was taken to task by a professor of computer science. I have, it seems, been unkind to Pascal and have confused the language itself with particular implementations. I pointed out that I can only evaluate implementations; this is the User's Column, and I don't generally write about stuff my readers can't use.

He agreed, but then told me with some vigor that there exists a public-domain UCSD Pascal that can be made to run on most CP/M S-100 bus systems. He also informed me that it's a wonderful implementation, complete with easy methods for opening and closing both sequential and random-access files under CP/M; features I very much want.

"Wow," I said. "How can I get this running?"

"Well, it's easy. If I had access to your system and your CBIOS (customized basic input/output system), I could have it running in no more than a day," he replied.

I quickly lost interest. Alas, I can't afford to have him come to Hollywood and install this marvel, nor, I fear, is that practical for many of my readers. I do recall that MacLean had an earlier version of UCSD Pascal running and had real problems with the built-in editor. It was also very slow. This caused him to learn PL/I, and he didn't live to return to Pascal.

If anyone has a simple and fool-proof way to get public-domain UCSD Pascal running, preferably on a Compupro 8085/8088 dual-processor machine with System Support board, Disk One controller, and Telewidget (officially Televideo, but at Chaos Manor things tend to get new names) 950 terminal, *please* let me know, so that I can pass the word along.

JRT Yet Again

I'm told I was unjustly hard on JRT Pascal.

I said nothing I care to retract, but perhaps the tone was unduly harsh; let me clarify. JRT Pascal certainly works in the sense that you can write useful programs in it. I like Mr. Tyson's price and attitude. His Version 3.0 has fixed a number of bugs and glitches that made earlier reviewers so unhappy.

For all that, JRT Pascal is not, in my judgment, a good teaching instrument because it is so thoroughly non-standard. The error messages are not the same as standard Pascal, and the extensions are done quite differently from the way anyone else does them. Programs written in JRT Pascal are almost guaranteed not to compile with *any* other Pascal compiler; worse, a number of standard programs out of such books as Osborne's *Practical Pascal Programs* won't compile on JRT either.

JRT Pascal error handling is not only nonstandard, but also unduly frightening to the beginning user; and the compiler never recovers from any error, so that JRT Pascal won't catch more than one error per compilation. For those who are as confused (or careless) about semicolons as I am, this can be very time consuming.

In other words, what it mostly has going for it is the price. You can write practical programs in JRT Pascal; if you're not interested in transporting those programs to some other machine, JRT is a bargain. To quote one programmer friend, though, I'd really hate having to write large programs in it.

Revolution at Digital Research

I'm told I had much to do with it. True or not, there's been a complete shake-up in Digital Research's document foundry. It's actually producing *readable and useful* documents with clearly written instructions and lots of *examples*. I used to dread opening a new DR manual. Now I find most of them a pleasure.

They also come in a brand-new format, a boxed loose-leaf notebook 9½ inches tall. At this height they will fit on most standard bookshelves; you don't need oversize shelves to hold

The IBM Personal Computer Work Station. It's optional. (But essential.)

Now, we could hard-sell you on its features. Or we could soft-sell you on its virtues. Instead, we're going to level with you.

You don't have to buy it.

But we have a hunch that the more you know about the IBM Synergetix® PC Work Station the more you'll wonder how your business ever managed without it.

Necessity was surely the mother of this invention.

For as more and more businesses come to rely on the personal computer, new and extraordinary demands are being placed on the work environment itself.

The IBM PC Work Station was specifically developed to meet the challenges of today's technology. And scientifically designed to satisfy the various needs of the people who use it.

It's not just another pretty desk.

First and foremost, the IBM PC Work Station provides a convenient and compact work space that instantly opens up to expand your work area.

In addition, the IBM PC Work Station offers added mobility for your personal computer. So you get more mileage out of your investment as it moves from office to office, person to person, solving problem after problem.

And since your personal computers are as vulnerable as they are valuable, the IBM PC Work Station also functions as a security device.

It deters pilferage by providing a self-contained lockable storage compartment for your CPU, software, keyboard, printer, program books and diskettes.

It also protects valuable information, prohibiting unauthorized access to confidential computer data by keeping it all secure under lock and key.

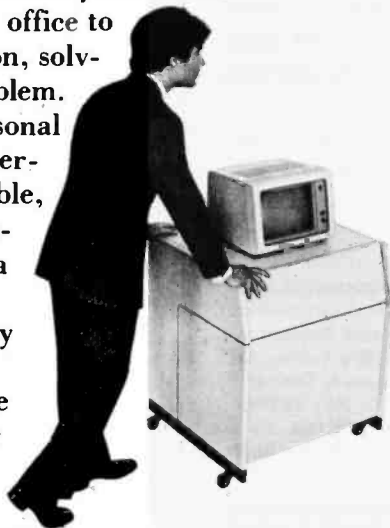
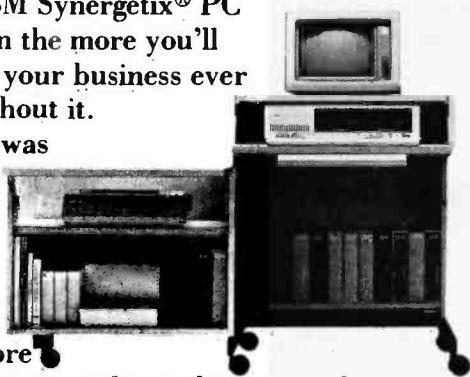

Last but not least, the IBM PC Work Station is

human-factor engineered to meet IBM's strict ergonomic standards for operator comfort.

For as you know, the more comfortable

people are, the more productive they can be.

There's one more important feature to our PC Work Station. It comes equipped with the added assurance of IBM quality. But then, that comes standard on all IBM products.

If all this hasn't convinced you that our PC

Work Station is as essential as it is exceptional, we're sure the price tag will. And IBM's quantity discounts make it absolutely irresistible.

To find out just how irresistible (or for additional information) call IBM Direct toll free at 1 800 631-5582* ext. 40 or visit one of our IBM Product Centers. Or send in the coupon below.

The IBM Personal Computer Work Station—business people are finding it's one of those luxuries they just can't live without.

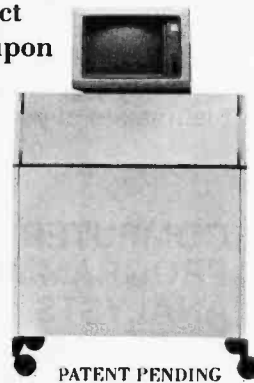

IBM PERSONAL COMPUTER WORK STATION

Mail to: IBM Corporation, Attn: IBM Direct,
One Culver Road, Dayton, New Jersey 08810

NAME _____ TITLE _____

COMPANY _____ TELEPHONE _____

ADDRESS _____

CITY _____ STATE _____ ZIP _____

*In Alaska and Hawaii call 1 800 526-2484 ext. 40.

your computer documents. The slip-case at first seems an affectation, but it isn't: the box serves as a place-holder to show where to put the document away when you're through with it.

The real revolution is inside, though.

CP/M-68K

The new CP/M-68K manual is a good case in point—it's actually readable! There's a sane preface, the introductory material is written in

plain English, there are plenty of examples, and there's considerable sympathy for beginners. The organization is nice, with an overview, then details, and, once again, *lots of examples*.

This clarity continues throughout the first volume (*User's Guide*) of the four-volume manual set. (All four volumes are bound into one loose-leaf notebook, which is a mistake; most users will prefer to buy another notebook and make two physical volumes of the set.) The second

volume, *System Guide*, and the third, *Programmer's Guide*, are not so clear, although both are *enormously* improved over previous DR CP/M documentation. I can't in conscience pronounce them excellent, but they are darned good, and such a great improvement over what we normally expect from DR that there's no comparison.

The fourth volume, *The C Language Programming Guide for CP/M-68K*, doesn't attempt to teach the C language. Two experienced C programmers tell me the CP/M C manual is more than adequate and superior to a lot of system documents they've encountered; one added, "Of course that's not saying much." It does have examples, and I haven't found anything that sent me up the wall. I haven't read it all, either. I suppose I added that last sentence, not to be catty, because of my previous experiences with Digital Research documents. That's probably unfair; the new documents are so darned good I ought, I suppose, to expect clarity and good examples rather than terseness and obscurity.

CP/M-68K and the Sage

When the CP/M-68K for the Sage first arrived, I'd expected the Comupro 68000 board for the S-100 bus experimental machine to come within a couple of days. Thus I waited for it so we could compare the systems. Alas, Dr. Godbout discovered a problem with his 68000 board and ceased shipping them until it could be fixed. Meanwhile, the Telewidget 925 terminal that operates the Sage was being used for installation of text editors, and I've only just got it back.

The upshot is that I've barely got CP/M-68K up and running on the Sage II.

It *does* run, and if you're used to CP/M it's easy to use. We haven't yet established communications between the Sage and other machines, so I haven't been able to ship over very many C programs. I did type in a couple of simple ones, and they compiled quickly and easily.

We've been running the Sage since last summer. It has been shipped to San Diego a couple of times for one

Martin Marietta Aerospace

Data Processing Opportunities

Martin Marietta Aerospace, NASA's prime Contractor for the Space Shuttle External Tank has immediate openings for Data Processing professionals. Because we actually manufacture the external tank, you'll get to see the actual results of your efforts.

COMPUTER PROGRAMMER/ ANALYSTS

Immediate opportunities exist for individuals experienced in:

- UNIVAC 1100
- ASC11 COBOL
- DMS 1100
- DDL, SDDL, DMU
- DML, QLP
- DPS 1100, TIP
- D/B Editor

• APPLICATION EXPERIENCE

Shop floor control, Scheduling, Manufacturing, Inventory, Purchasing, Configuration Management, Quality Engineering.

• DATA BASE OPENINGS

Analyst, Design, Administrators with above hardware, software and applications experience.

These opportunities exist at our Michoud Assembly Facility located in suburban East New Orleans.

Qualified candidates interested in learning more about these opportunities at Martin Marietta should forward resumes, including salary history to Martin Marietta Aerospace, Denver Glazier, BYTE-883, P.O. Box 29304, New Orleans, Louisiana 70189. We are an equal opportunity employer, m/f/h.

MARTIN MARIETTA

NEW 68000 GROWS WITH YOU WICAT System 155

Here's the flexibility you've been waiting for. Extra MULTIBUS™ slots allow expansion with extra memory and/or a wide variety of devices for business, engineering, and software development uses.

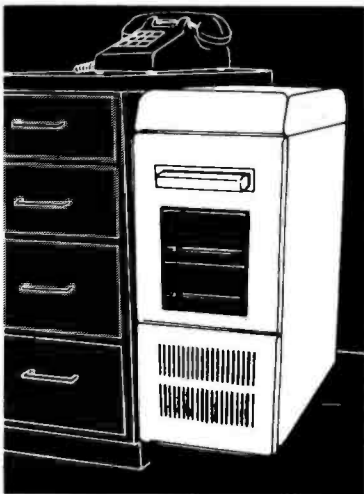

- Motorola 68000 • 512KB memory
- 12 MULTIBUS™ slots (3 occupied)
- MCS operating system, utilities, and choice of language.

\$9390

Three devices can be added as options, including:

- Winchester disk (10MB, 15MB)
- New Winchester disk (33MB, 45MB)
- floppy disk (630KB)
- cartridge tape (17MB)
- expansion to 12 users
- New hardware floating point arithmetic

SOFTWARE

- integral™ database and MenuSystem™
- complete business system
- New bisync communication to IBM mainframes
- UNIX™



Concurrent™ Corporation
1870 Madison Road Cincinnati, Ohio 45206
(513) 281-1270 • TELEX 170980

integral and MenuSystem are trademarks of Concurrent Corporation.
UNIX is a trademark of Bell Laboratories.
MULTIBUS is a trademark of Intel Corporation.

of Alex's mad friends to experiment with. Because it's the only machine I have that runs Modula-2, it got a good workout while I was learning that language.

We've yet to have a glitch. About a dozen readers tell me they bought Sage machines largely on my recommendation, and none of them are unhappy. Now that we have CP/M for the Sage, I expect to use it even more. Incidentally, I'm beginning to see software written for the Sage. A database came in today. The Sage is becoming an important little machine.

Disassembling Adelle

Adelle is my early-model Otrona Attache. She goes with me on all my travels. Recently she developed a glitch in her disk systems. It happened on a Thursday afternoon; the following Saturday at dawn Larry Niven and I were scheduled to catch a plane for Bellingham, Washington, where we've laid a principal scene of our next novel.

In panic I called Fred Whitney of CTI Data Systems. CTI is the West Coast representative for Otrona. Fred listened to my tale of woe.

"We could swap out your disk drives," he said. "But I couldn't get it done before Monday because I don't have a set of drives here."

My panic must have been evident because he told me to hang on. A few minutes later Judy Seelig, Mr. Whitney's programming expert, called. She thought my problem had to do with disk drive speeds. "There's an information sheet from Otrona on how to fix that," she said. "I've never done it, but I'll come out and we can work on it together. There's a new software ROM update, and we can install that while we're at it. To save time, please take the machine apart before I get there."

With some misgivings I spread a thick layer of newspapers across my desk and took Adelle out of her case. She came apart quite easily; it takes only one tool, a Phillips screwdriver. I began to remove parts: the circuit board, the screen, the power supply, the disk drives. It wasn't long before my pretty little machine was a pile of

parts and small screws, and I was getting a little worried. "It'll be all right," I told Chuck McMannis. "She told me to take it apart, so she'll know how to get her together . . ."

There was only one problem. Judy Seelig had *never* seen a machine taken quite so thoroughly apart, and she hadn't brought any documents on how to reassemble Adelle.

"Relentless application of logic," I muttered. We installed the new ROM, and I began to put parts on and tighten screws. In about 10 minutes everything was back together. Then we removed the disk drives and proceeded to follow the instructions Otrona sent for adjusting disk speed.

In another 10 minutes Adelle was back together and working as well as ever she has. That's one well-designed little machine. I don't recommend that you casually take yours apart, but I can testify that, provided you're intelligent about reassembly, it doesn't seem to hurt the machine.

Incidentally, I discover there's a whole series of built-in diagnostic tests for the Otrona. They're described in the *Technical Manual*, a document normally supplied to dealers, but which users can purchase.

I'm not too happy about those disk drives. They do indeed have a speed control. It's a screwdriver-adjusted potentiometer. A *tiny* turn of that pot will put the speed wildly off. I'd have thought they'd want something a lot less sensitive. Indeed, while we were in Bellingham a speed problem developed again, forcing me to remove Adelle's case and adjust her "B" drive. It was easily fixed, but I hope I won't have to endure that every trip.

Adelle is an older-model machine. The new ones have somewhat different disk drives. Fred Whitney tells me they've never seen any problems with the new ones.

Things My Postman Brings Me . . .

John Lawler of Ann Arbor, Michigan, writes in praise of VEDIT, particularly used with the TVI 950 terminal. He's been using VEDIT for

The Micromint Collection

Micromint. Supporting the varied projects that appear in Steve Ciarcia's monthly article in *BYTE* magazine, "Ciarcia's Circuit Cellar." Offering a wide range of computers and peripherals supporting the needs of the hobbyist as well as worldwide corporate clients.

MPX-16 MICROCOMPUTER IBM PC COMPATIBLE



The MPX-16 is Steve Ciarcia's most ambitious project to date. The computer runs all application software written for the IBM PC and is IBM PC bus compatible. Can be used with video monitor & IBM keyboard with optional adapter.

Buy the MPX-16 in the form that best meets your budget. As a bare board, as a wave-soldered board that contains all components less the IC's, as an assembled and tested circuit board or as a complete system.

As featured on the cover of "BYTE" magazine. Also featured in "Ciarcia's Circuit Cellar" November, December 1982 & January 1983.

- Runs all application programs written for the IBM PC (simply boot up the system and slip in a disk formatted for the IBM PC).
 - IBM PC bus compatible + 9 expansion slots.
 - Intel 8088 16-bit microprocessor
 - Optional Intel 8087 math coprocessor.
 - 256K bytes on-board memory.
 - Up to one megabyte of system memory.
 - Up to 64K bytes of system ROM-EPROM.
 - Two RS-232C serial I/O ports.
 - Three parallel I/O ports.
 - Disk controller for 5 1/4" or 8" drives.
 - Sixteen levels of vectored interrupts.
- MPX-16 Microcomputer circuit board assembled w/64K RAM, CP/M-86 or MS-DOS \$1,895.
- MPX-16 as above with 256K RAM 2,135.
- MPX-16 Semi-Kit (wave soldered circuit board w/all components) less IC's 595.
- Complete kit of IC's w/ 256K RAM 595.
- MPX-16 Unpopulated (bare) pc board 300.
- CP/M-86 Operating System 200.
- MS-DOS optionally available
- MPX-16 Switching Power Supply Including cable harness for 2 disk drives 300.
- MPX-16 Technical Reference Manual 50.
- MPX-16 Metal Enclosure with cutouts for two 5 1/4" full height drives 300.
- Tandon TM 100-2 double density drive 300.
- Televideo Model 910 Serial Terminal 675.
- IBM PC Keyboard Interface Adapter 100.
- Serial terminal cable 35.
- Parallel printer cable 35.
- Shipping and handling additional on MPX-16 orders.

Z8 BASIC SYSTEM CONTROLLER NEW!!!

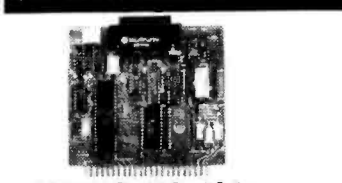

- Replaces Z8 Basic Computer Controller
- As featured in Ciarcia's Circuit Cellar, *BYTE* magazine, July & August 1981.
- Uses Zilog Z8671 single chip microcomputer.
 - On board tiny BASIC interpreter.
 - 2 parallel ports plus serial I/O port.
 - Just connect a CRT terminal and write control programs in BASIC.
 - 2K bytes of RAM, up to 4K bytes of ROM.
 - Baud rates 110-9600 BPS.
 - Data and address buses available for 124K memory and I/O expansion.
 - Consumes only 1.5 watts at +5, +12 & -12.
 - Cross Assemblers for various computers.
- BCCT1 Assembled & Tested \$149.
- New Low Price

Z8 MEMORY, I/O EXPANSION, CASSETTE INTERFACE

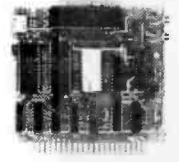

- Add up to 8K of memory plus 3 parallel ports.
 - Cassette Interface—300 baud K.C. Standard.
- BCC03 w/4K Assembled & Tested \$140.

Z8 ANALOG TO DIGITAL CONVERTER NEW!!!

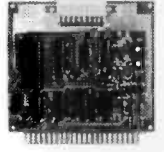

- Uses Analog Devices 7581 8 channel 8 bit IC.
 - Adds Process Control capability to the Z8.
 - 1000 samples per second.
- BCC13 Assembled & Tested \$140.

Z8 EPROM PROGRAMMER

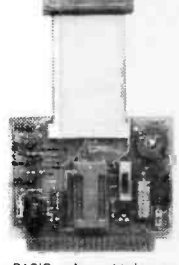

- Transfer BASIC or Assembly Language application programs from RAM to 2716 or 2732 EPROM.
 - Requires Z8 Expansion Board for operation.
- BCC07 Assembled & Tested \$145.

Z8 SERIAL EXPANSION BOARD

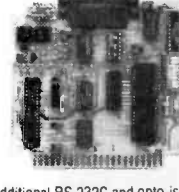

- Adds additional RS 232C and opto-isolated 20 ma current loop serial port to the Z8.
 - Runs at 75 to 19,200 baud in all protocols.
- BCC08 Assembled & Tested \$160.

Z8 16K MEMORY EXPANSION BOARD NEW!!!

- Add 16K of additional memory, RAM or EPROM. to your Z8 System Controller in any multiple.
 - Uses 2016, 6116, 2716 or 2732 memory types.
- BCC14 w/8K Assembled & Tested \$120.

Z8 FIVE SLOT MOTHER BOARD



MB02 Assembled & Tested \$69.

Z8 CROSS ASSEMBLERS

- From Allen Ashley
- TRS-80 Model I or III \$75.
- CP/M 2.2 8" or Northstar 5 1/4" 150.
- From Micro Resources
- CP/M 2.2 8" or APPLE 5 1/4" 75.

SPEECH SYNTHESIZERS

MICROVOX TEXT-TO-SPEECH SYNTHESIZER

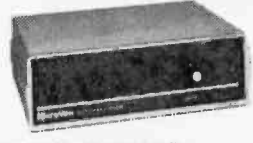

As featured in Ciarcia's Circuit Cellar *BYTE* Magazine September, October 1982.

- Microvox is a second generation professional voice quality text-to-speech synthesizer that is easily interfaced to any computer, modem, RS-232C serial or parallel output device and provides speech of unbelievable clarity.
- Unlimited vocabulary.
 - 64 programmable inflection levels.
 - 6K text-to-speech algorithm.
 - Full ASCII character set recognition and echo.
 - RS232C and parallel output.
 - 1000 character buffer, 3000 optional.
 - Adjustable baud rates (75-9600).
 - Spelling output mode.
 - 7 octave music and sound effects.
 - On board audio amplifier & power supply.
 - X-On/X-Off handshaking.
- MV01 Assembled with 1K buffer \$299.
- MV02 Complete Kit with 1K buffer 219.
- Add \$15.00 for 3K buffer option.

SWEET-TALKER VOICE SYNTHESIZER

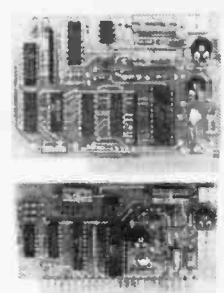

As featured in Ciarcia's Circuit Cellar *BYTE* Magazine, September 1981

- The Sweet-Talker Voice Synthesizer allows you to add speech of unlimited vocabulary to your Apple II or any computer with a parallel printer port at very low cost.
- Utilizes Votrax SC-01A speech synthesizer.
 - Unlimited vocabulary.
 - Text-to-Speech Algorithm on disk for Apple II.
 - Contains 64 phonemes accessed by 6-bit code.
 - Four levels of programmable inflection.
 - On board audio amplifier & volume control.
- ST02 Apple II plug-in, Assembled & Tested with Text-to-Speech Algorithm on 3.3 disk ... 141.
- NEW LOW PRICE!!!**
- ST01 Parallel Port Version, Assembled 99.
- New Low Price

VOTRAX SC-01A PHONETIC SPEECH SYNTHESIZER

- The SC-01A Speech Synthesizer is a completely self-contained solid state device that phonetically synthesizes continuous speech of unlimited vocabulary. Used in Microvox and Sweet-Talker.
- SC01A Quantity 1-99 \$52. ea.
- 100 + 40. ea.
- 1000 + 30. ea.

E-Z COLOR GRAPHICS INTERFACE

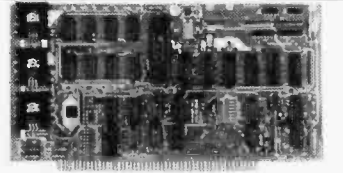

As featured in Ciarcia's Circuit Cellar *BYTE* Magazine, August 1982

- Add color graphics, animation & 3-D effects to your S-100, TRS-80 Model I and III & Apple II at low cost. The Super Editor software package includes a pattern editor, sprite editor, slide show, and demo scenes all in BASIC. Can be used with Color Monitor or TV set and rf modulator.
- Resolution—256 X 192 Pixels.
 - 16 colors including Black & Transparent.
 - 16K Bytes on board I/O mapped video memory.
 - Advanced TI TMS9918A Color Video Processor.
 - 32 SPRITES facilitates 3-D effect.
 - Composite Video output.
 - Krell & Terrapin have LOGO software packages to support the E-Z Color Boards.
- Apple II E-Z Color plug-in board with Super Editor on 3.3 disk.
- EZ01 Assembled & Tested \$150.
- EZ02 Complete Kit 125.
- NEW!!** S-100 E-Z Color Graphics board with sound generator, Atari type joy stick interface, plus MBasic CP/M Super Editor Software on 8" disk.
- EZ04 Assembled & Tested \$289.
- TRS-80 Model I or Model III E-Z Color w/ Super Editor software, power supply and enclosure.
- Assembled & Tested \$249.
- Complete Kit 219.

300 BAUD ANSWER/ ORIGINATE MODEM KIT NEW!!!

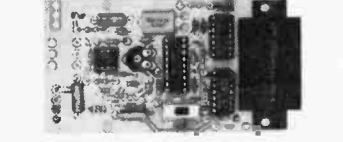

As featured in Ciarcia's Circuit Cellar *BYTE* Magazine, March 1983

- The newest item to Micromint's growing list of products is this 300 Baud Modem. It is crystal controlled, uses the TI TMS 99532 IC, contains just 25 parts and can be used with an acoustic coupler or in a direct connect mode.
- MD04 Complete Kit \$60.
- MD05 Transformer for Direct Connect Mode 9.
- AC01 Acoustic Coupler Kit 18.

TRIPLE VOLTAGE POWER SUPPLIES

- + 5v @ 300 ma. +/- 12v @ 25 ma.
- UPS01 Assembled & Tested \$35.
- UPS02 Complete Kit 27.
- + 5v @ 1 Amp. + 12v @ .5 Amp. - 12v @ 50 ma.
- UPS03 Assembled & Tested 60.
- UPS04 Complete Kit 50.

MICROMINT INC. 561 Willow Avenue, Cedarhurst, NY 11516

To Order: Call Toll Free 1-800-645-3479

For Information Call: 1-516-374-6793

Call: Monday-Friday, 9-5 PM

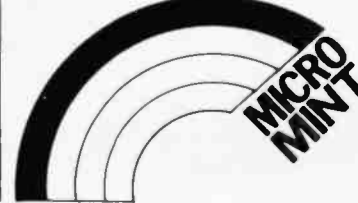

IBM PC, is a trademark of International Business Machines. Inc.
CP/M86 is a trademark of Digital Research Inc.
MS-DOS is a trademark of Microsoft Inc.
Z8 is a trademark of Zilog Inc.

Items Reviewed

CP/M-68K \$350
Digital Research
POB 579
Pacific Grove, CA 93950
(408) 649-3896

Epson FX-80 Printer \$699
Epson QX-10 Computer with 64K-byte RAM \$2495
Epson America Inc. with 128K-byte RAM \$2995
Computer Products Division
3415 Kashiwa St.
Torrance, CA 90505
(213) 539-9140

JRT Pascal \$29.95
JRT Systems
45 Camino Alto
Mill Valley, CA 94941
(415) 388-0530

Zenith Z-29 Terminal \$849
Zenith Data Systems
1000 Milwaukee Ave.
Glenview, IL 60025
(312) 391-8865

Book Reviewed

Word Processing Buyer's Guide \$15.95
Arthur Naiman. Hightstown, NJ: BYTE/McGraw-Hill, 1983, softcover

some time and likes it.

I like it too. My quarrel with VEDIT is that the installation and customization procedures are darned complex: in the version that was sent me, you had to answer 34 questions, and if you made a single mistake while doing it (not even Backspace was permitted for correcting the answers you had to give!) you had to start all over. I complained—bitterly—and the last I heard the VEDIT people were rewriting those procedures to make them easier to use.

I have two editors I can use on the Zenith Z-100: VEDIT and Superwriter. Both are very nice, and I hope to report on each in a future column. Meanwhile, several readers have written to praise VEDIT. The VEDIT philosophy is to have *tons* of special functions, so that each of the myriad special-function keys on the Telewidget can be made to do something special; as Mr. Lawler says, you can get "touch editing." This can be pretty useful, especially in a programming editor.

Philippe Malarne of Brussels, Belgium, writes: "On different occasions you complained in BYTE about poor and overpriced documentation, but I don't think you've met a worse case than Supersoft's Ada . . . their 'document' consists of a Xerox copy of the Department of Defense Ada specifications (1980 version) and *Ada Supersoft User's Manual*, a book of 30 pages!

"The worst is yet to come: of the 30 pages, 2 are a 'software agreement' which disclaims any warranty or responsibility . . . and three list 'Standard Ada unimplemented features.' . . . Their compiler is an Ada subset the way Sinclair's ZX81 is a subset of the Cray-1 computer."

I don't have Supersoft Ada, but P. Malarne's letter is typical of those I've received from those who've bought it.

James Tower writes in behalf of a number of computer users in Germany, where they are condemned to 50-Hz power at 220 volts. Tower had decided on a Lobo Max-80 computer,

when he discovered that Lobo won't guarantee that it can work with a 50-Hz power source. The monitor seems to be the major problem: the company is afraid the display will "swim." Moreover, Lobo doesn't want to guarantee a machine in Europe because it would have to reimport it if something went wrong.

Mr. Tower paints a pretty gloomy picture of what it must be like on the continent just now. Most products aren't available, and those that are seem overpriced. He thinks Lobo would have a very clear field, even at prices well above those currently advertised, if they had a package deal for export to Germany.

I can sympathize with Tower without knowing what to do. One of the few serious complaints I've had about Godbout/Compupro came from a German purchaser. Communications take forever, and shipping equipment back and forth is very expensive.

In any event, Mr. Tower wonders if there might be a simple solution to the problem of adapting a Lobo Max-80 to eat German electricity and still deliver stable video output. That seems more in Ciarcia's department than mine; perhaps Steve can answer. Meanwhile, I can report that Barry Workman continues to rely on his Lobo Max-80 as one of his principal machines; Ralph will read a wide variety of disk formats and has given him no trouble at all.

Some months are worse than others: this month I got bales of mail, and I'll hardly be able to answer any of it, what with all the other demands on my time. April is the cruelest month . . . ■

Jerry Pournelle welcomes readers' comments and opinions. Send a self-addressed, stamped envelope to Jerry Pournelle, c/o BYTE Publications, POB 372, Hancock, NH 03449. Please put your address on the letter as well as on the envelope. Due to the high volume of letters, Jerry cannot guarantee a personal reply.

Jerry Pournelle is a former aerospace engineer and current science-fiction writer who loves to play with computers.

Now anyone can write complex dBASE II™ Programs without any programming experience whatsoever. Autocode is the quickest and easiest.

IBM/PC VERSION NOW IN STOCK



This powerful program generator for dBASE II™ is available for all CP/M 80, 86 or CP/M operating systems derivatives such as MS/DOS or PC/DOS, as well as any Z80 or 8080/8085 systems, as in: APPLE, IBM/PC, KAYPRO, NORTHSTAR, OSBORNE, SUPERBRAIN, TELEVIDEO, VICTOR 9000, ETC.

- Automatic menu & sub menus
- Automatic data entry screens
- Automatic data entry routines
- String, numeric, date & calculated fields
- Automatic multiple reports
- Automatic programs in dBASE II™ code with interactive screens

- No prior knowledge of dBASE II™ required
- CP/M™ & MS DOS™ operating systems
- Very easy to learn. Autocode asks you what you want to do in menu form.
- The code produced impresses the most experienced programmer.

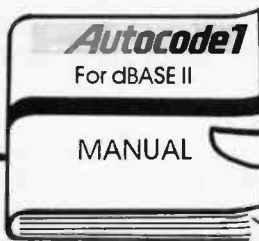

ONLY \$200.

STEMMOS LTD.

666 Howard Street, San Francisco, CA 94105 / Tel: (415) 777-3800

Just send the following to address above today.

- Your diskette format & hardware
- How many Autocodes you want at \$200 each*
- Your name & complete address
- A check or money order.

*In CA add 6% sales tax



Credit card buyers may substitute their card number and expiration date for the check. Or call us toll free and save the trip to the mail box.

IRONCLAD GUARANTEE

Try AUTOCODE Risk Free

The AUTOCODE 1 Program Generator you receive will be complete and unabridged. Use it for 30 days. If for any reason whatsoever you decide it's not for you, return it to us and we will gladly refund your money (less shipping). No questions asked.

ORDER TOLL FREE 800-227-1617 (Ext. 417)
IN CA CALL 800-772-3545 (Ext. 417)

Dealer inquiries invited.

IBM is a registered trademark of International Business Machines, Inc. dBASE II™ Ashton Tate. CP/M is a registered trademark of Digital Research, Inc. Autocode 1™ Stemmoss Ltd.

Voice Lab

Part 2: Menu-Driven Routines for Digital Speech Synthesis and Analysis

UCSD Pascal units form a modular voice workbench

by John E. Hoot

In part 1 (July, page 186) we looked at the theory behind the operation of the Voice Lab system. This month, we'll see how it works in practice.

Voice Lab Operation

The experimenter's interface to Voice Lab is menu-driven and highly interactive. Like any workbench, it was constructed to keep the tools handy and to minimally constrain what is constructed. (For a review of the functions of different Voice Lab units, see table 1.)

When the main program, shown in listing 1, is first executed, the primary function menu appears across the top of the screen in the usual style associated with the UCSD p-System. The options presented are

Voice Lab:
D(ictionary)

Numbering of figures and tables is continued from Part 1.

UCSD Pascal is a registered trademark of the Regents of the University of California. Use thereof in conjunction with any goods or services is authorized by specific license only, and any unauthorized use is contrary to the laws of the State of California.

p-System is a trademark of Softech Microsystems, Inc.

R(ecord & listen
Statistics
M(essages
F(ilter
Q(uit

By striking one character (the one preceding the parenthesis) you may select the desired subsidiary screen menu. Typically, a subsidiary screen's resulting data is not erased when you return to the primary menu, but you may erase it by typing a space. Now let's take a look at how the program's subsidiary menu screens operate.

Dictionary

When the dictionary menu is selected, the unit (listing 2) displays a prompt line at the top of the display indicating the available options:

Dictionary:
D)irectory
R)emove
A)ppend
I)nsert
C)lear
Q)uit

Typing the character preceding the parenthesis selects the desired option. Pressing the space bar will erase

any information remaining on the screen from a previous operation.

The Directory option displays the contents of the current vocabulary in three columns. The left-hand column contains an index to the vocabulary word, the middle column contains the word, and the right-hand column displays the size in bytes of the encoded speech segment stored for that word. Table 4 in part 1 (July, page 196) showed a segment of the sample output from this command.

The Remove command is used to delete unwanted entries from the dictionary.

The Append command is primarily used during speech analysis. Its function is to append to the current contents of the speech buffer a word or phrase stored in the dictionary. By using Append, you can assemble a phrase in the speech buffer for study. For instance, you could append the words "how," "are," and "you" to obtain the phrase "How are you."

The Insert command adds the contents of the speech buffer to the dictionary. The example below illustrates how to insert the word "through" and its homonyms into the dictionary, presuming that the word has already been captured in the speech buffer. Both the computer's output and the user's input are shown.

Word or phrase name:throughReturn

Enter Homonym :thruReturn

Enter Homonym :threwReturn

Enter Homonym :Return

When you answer the final prompt with just the Return key, the word and all of its homonyms will be added to the dictionary. The program then replies:

THROUGH, THRU, THREW added to dictionary.

The Clear command disposes of the entire dictionary. It allows you to discard your present dictionary and begin to build a completely new one. If you select this function, the program double-checks your intent.

The Quit command from the dictionary screen returns the program to the main prompt menu.

Record and Listen Menu

The Record and Listen menu, shown in figure 6 on page 469, controls the functions in which audio speech segments are captured and then played back. Its functions can isolate words or phrases from the speech buffer and control sampling rates for D/A (digital to analog) and A/D (analog to digital) conversion.

The Set Tempo item in the menu controls the rate of playback and recording digitization. Depending on exactly how the Analog I/O unit works in your system, the default rate may require modification. Recording at a normal rate and playing back at a higher rate has the same effect as listening to a 45-rpm phonograph record at 78 rpm. If your intent is to produce normal speech, you should always play back at the same rate as you recorded the input. You can vary the tempo to discover the minimum sampling rate that produces acceptable speech on your system.

The Beginning and End menu items each set one of two indexes that delineate the portion of the speech buffer upon which the program will operate. All operations in Voice Lab are bound by these indexes. As an ex-

Analog I/O Unit

services provided:

- analog output from the speech buffer
- digitizing speech into the speech buffer

resources provided:

- 16K-byte speech buffer
- tempo-rate variable

Voice Dictionary Unit

services provided:

- vocabulary word look-up
- vocabulary word insertion
- vocabulary word deletion
- vocabulary word retrieval
- dictionary erasure

Voice Messages Unit

services provided:

- word-to-speech output
- string-to-speech output

Voice Display Unit

services provided:

- zero-crossing counts and plots
- spectral-energy plots
- total speech-energy plots
- signal-level monitoring

Voice Filter Unit

service provided:

- interactive linear digital filtering

Table 1: Summary of functions of Voice Lab units (repeated from part 1).

ample, you might originally set the Beginning parameter to 0 and the End parameter to 9999 (using the whole buffer), and record the phrase "one, two, three." By adjusting Beginning and End to 2800 and 3500, respectively, you might isolate the word "two" in the speech buffer.

The Record operation causes the following prompt to be displayed in the upper left-hand corner of the display:

Hit <ret> then speak

You can synchronize the beginning of your speech with the beginning of the digitization process. Upon completion of digitization, this prompt is replaced by the response:

Done!

The Play function reconstructs the contents of the speech buffer through the A/D converter on your computer.

Upon quitting the Record and Listen menu, all the information on the screen and in the speech buffer is preserved. Thus, assuming that the speech buffer contains the word "two," you could enter the dictionary menu and append the word "go" to the speech buffer; this would increment the End index of the speech buffer and leave the speech buffer containing the phrase "two go."

Statistics Menu

The Statistics menu controls the generation of the plots by the Voice Display Unit (listing 3). The options of the main statistics screen are as follows:

Stats:
E(nergy & Crosses
P(lot
A(vg
M(ax & min
S(pectrum
Q(uit

Text continued on page 469

Nobody offers you a wider variety of computer printers and printer experience than Facit/Dataroyal... all the way from low cost (\$695 list) matrix printers, to sophisticated graphics and color matrix printers, to models that print variable size characters and bar codes, to "daisy wheels" and a multimode near letter-quality printer. Industry standard parallel and RS232C serial interfaces are available in all printers.

Our products are built to perform day after day in the most rugged

environments. We achieve that kind of reliability by incorporating modern, trouble-free LSI circuitry, and fewer moving mechanical parts along with a high level of quality control.

Hundreds of computer systems manufacturers choose Facit/Dataroyal products with confidence, as do a great number of Fortune 500 companies who use Facit/Dataroyal peripherals with their systems.

If you want a trouble-free printer, contact your local computer

printer dealer or Facit/Dataroyal, 235 Main Dunstable Road, P.O. Box 828, Nashua, NH 03061, (603) 883-4157.



**FACIT
DATAROYAL**

Circle 503 on Inquiry card.

Printers, printers, and more printers.

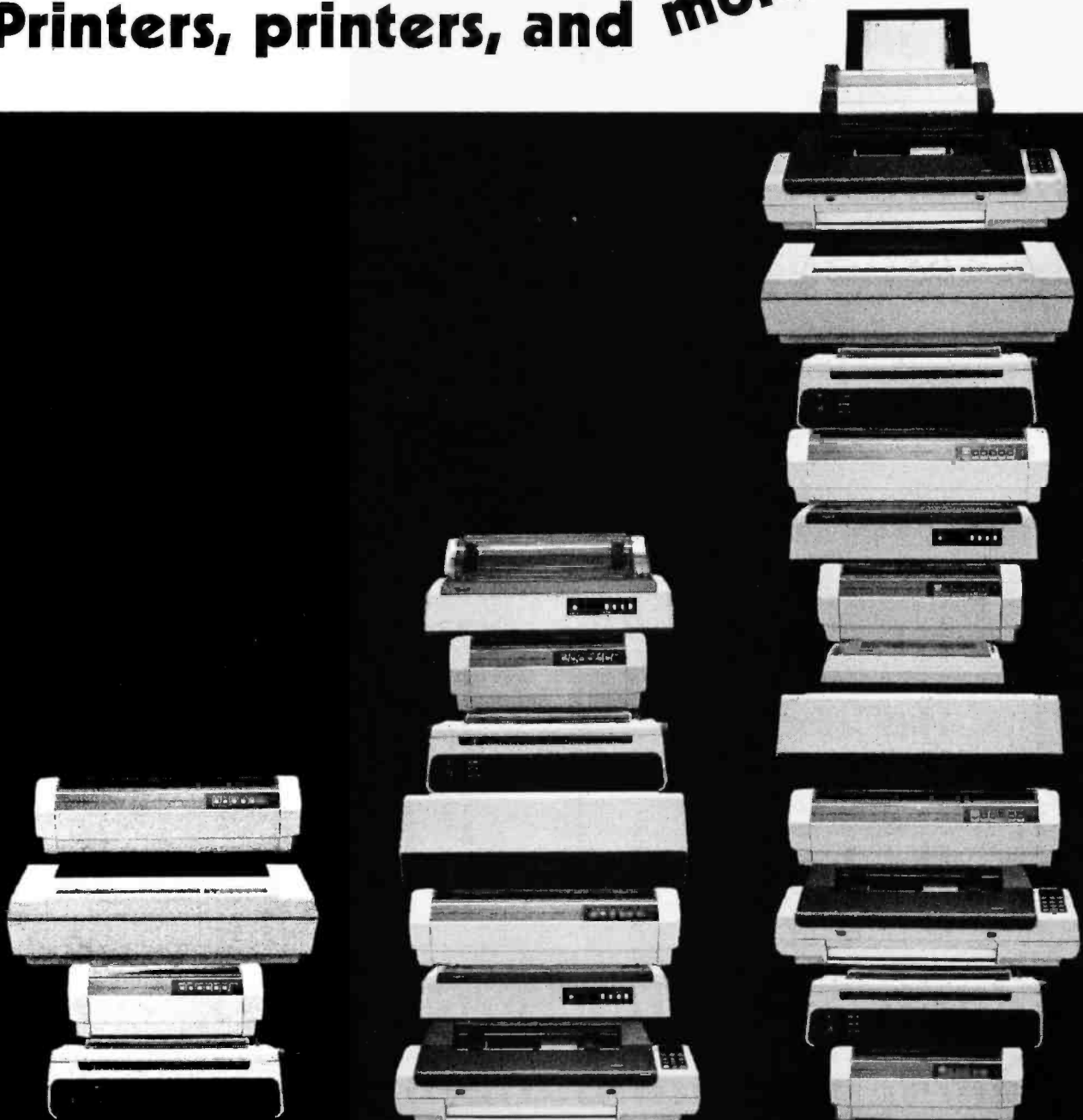

```

110 2 1:u 1 ( VOICELAB TEXT-TO-SPEECH OUTPUT )
111 2 1:u 1 ( SERVICE UNIT )
112 2 1:u 1 ( )
113 2 1:u 1 ( [Copyright John E. Hoot 1983. All rights )
114 2 1:u 1 ( reserved )
115 2 1:u 1 ( )
116 2 1:u 1 ( )
117 2 1:u 1 ( )
118 2 1:u 1 ( function speakword( s:string ): boolean;
119 2 1:u 1 ( procedure speakline( n:string );
120 2 1:u 1 ( [SU Voice.msg.code) voice_msg,
121 2 1:d 1 ( )

122 2 1:u 1 Using VOICEDSP
123 2 1:u 1 ( )
124 2 1:u 1 ( )
125 2 1:u 1 ( VOICELAB PCM SPEECH ANALYSIS UNIT )
126 2 1:u 1 ( )
127 2 1:u 1 ( [Copyright John E. Hoot 1983. All rights )
128 2 1:u 1 ( reserved )
129 2 1:u 1 ( )
130 2 1:u 1 ( )
131 2 1:u 1 ( )
132 2 1:u 1 ( procedure display;
133 2 1:u 1 ( )
134 2 1:u 1 ( [SU Voice.dep.code) voice_dep,
135 2 1:d 1 ( )

136 2 1:u 1 Using VOIDEFIL
137 2 1:u 1 ( )
138 2 1:u 1 ( )
139 2 1:u 1 ( VOICELAB PCM SPEECH RECURSIVE DIGITAL )
140 2 1:u 1 ( FILTERING UNIT )
141 2 1:u 1 ( )
142 2 1:u 1 ( [Copyright John E. Hoot 1983. All rights )
143 2 1:u 1 ( reserved )
144 2 1:u 1 ( )
145 2 1:u 1 ( )
146 2 1:u 1 ( )
147 2 1:u 1 ( procedure filter;
148 2 1:u 1 ( [SU Voice.ftr.code) voice_filter,
149 2 1:d 1 ( )

150 2 1:u 1 Using ANALOGIO
151 2 1:u 1 ( )
152 2 1:u 1 ( )
153 2 1:u 1 ( VOICELAB ANALOG INPUT/OUTPUT )
154 2 1:u 1 ( SERVICE UNIT )
155 2 1:u 1 ( )
156 2 1:u 1 ( [Copyright John E. Hoot 1983. All rights )
157 2 1:u 1 ( reserved )
158 2 1:u 1 ( )
159 2 1:u 1 ( )
160 2 1:u 1 ( const vox_bufLen = 16083;
161 2 1:u 1 ( )

type vox_bufLen = 0..vox_bufLen;
byte = 0..255;
vox_buffer=packed array[vox_bufLen] of byte;
vox_ptr = ^vox_buffer;

var tempo,start,stop:vox_bufLen;
stream:vox_ptr;

procedure ADC( var ptr:vox_buffer;
offset, len: vox_bufLen; rate:integer );

procedure DAC( var ptr:vox_buffer;
offset, len:vox_bufLen; rate:integer );

[SU Analog.io.code) analog_io;

var c:char;

procedure message;

var result,dummy:integer;
s:string;
c:char;
f:text;

begin
sc_ptr:=sc_ptr;
repeat
c:=sc_prompt('Messages: L(fire), F(file), Q(quit )
[F],if',L',L',Q',q',false,'');
case c of
'L':sc_ptr:=sc_ptr;
'F':f:=f;
'Q':quit:=quit;
'F':f:=f;
begin
while not(eof(f))
do begin

```

```

222 2 2:8 233      readln(f,s);
223 2 2:6 246      speakline(s);
224 2 2:7 250      end;
225 2 2:6 252      close(f);
226 2 2:5 258      end;
227 2 2:3 25E     end;
228 2 2:2 260      until (c='0') or (c='q');
229 2 2:1 263      sc_clr_screen;
230 2 2:1 277      end;
231 2 1:0 0
232 2 1:0 0
233 2 1:0 0
234 2 1:d 1
235 2 3:d 1      var result:dict_result;
236 2 3:d 2      f:=ln,dummy:integer;
237 2 3:d 5      c,chtchar;
238 2 3:d 7      done:boolean;
239 2 3:d 8      s:=string;
240 2 3:d 80
241 2 3:0 0
242 2 3:1 0      sc_clr_screen;
243 2 3:1 2      repeat
244 2 3:2 2      c:=sc_prompt(concat('Dictionary: D)ifactory, R)remove, A)ppand, '
245 2 3:2 20      ['I]insert, C)lear Q)ut ',f-1,0,0,0,
246 2 3:2 38      ['d','r','e','c','q','d','r','A','I','C','Q',' '],
247 2 3:2 46      false, ' ');
248 2 3:2 52      case c of
249 2 3:2 58      'D','d':begin
250 2 3:4 56      i:=i;
251 2 3:4 56      writeln;
252 2 3:4 84      done:=false;
253 2 3:4 56      while [not done] end index_word( f,s, ln )
254 2 3:4 73      do begin
255 2 3:6 78      writeln(i:3;st20;ln:10);
256 2 3:6 110      i:=i+1;
257 2 3:6 113      if (i mod 23)=23 then
258 2 3:7 123      begin
259 2 3:8 123      if not space_wait(false) then
260 2 3:8 129      done:=true;
261 2 3:8 129      else sc_clr_screen;
262 2 3:8 135      writeln;
263 2 3:7 141      end;
264 2 3:5 141      and;
265 2 3:4 143      if not done then
266 2 3:5 146      write('Dictionary contains ',f-1,' entries. ');
267 2 3:3 179      end;
268 2 3:2 182      'R','r':begin
269 2 3:4 182      sc_clr_screen;
270 2 3:4 184      write('Remove what word? ');
271 2 3:4 186      readln(s);
272 2 3:4 212      if s<>' ' then
273 2 3:5 222      begin
274 2 3:6 222      result:=remove_word(s);
275 2 3:6 229      case result of
276 2 3:6 232      successful: writeln(s, ' removed. ');
277 2 3:6 262      not_found: writeln(s, ' not in dictionary. ');
278 2 3:6 292      end;
279 2 3:5 285

```

Listing 1 continued:

```

340 2 4:2 134 gotoxy(0,0);
341 2 4:2 138 read[keyboard,c];
342 2 4:2 146 case c of
343 2 4:2 150 'r','r':begin
344 2 4:4 155 gotoxy(0,0);
345 2 4:4 155 memlock('ANALOGIO');
346 2 4:4 163 readln;
347 2 4:4 175 write[hit <ret> then speak'];
348 2 4:4 181 add[STREAM,start,stop-start,tempo];
349 2 4:4 208 writeIn('Done!');
350 2 4:4 227 memswap('ANALOGIO');
351 2 4:4 235 gotoxy(0,0);
352 2 4:4 240 write[
353 2 4:3 252 ];
354 2 4:2 255 'p','p':dec[stream,start,stop-start,tempo];
355 2 4:2 265 'S','s':begin
356 2 4:4 285 gotoxy(37,5);
357 2 4:4 281 write[
358 2 4:4 303 gotoxy(37,5);
359 2 4:4 309 readln[tempo];
360 2 4:3 324 end;
361 2 4:2 328 'B','b':begin
362 2 4:4 328 gotoxy(37,6);
363 2 4:4 332 write[
364 2 4:4 344 gotoxy(37,6);
365 2 4:4 350 readln[start];
366 2 4:3 365 end;
367 2 4:2 367 'E','e':begin
368 2 4:4 367 gotoxy(37,7);
369 2 4:4 373 write[
370 2 4:4 385 gotoxy(37,7);
371 2 4:4 391 readln[stop];
372 2 4:3 408 end;
373 2 4:2 408 end;
374 2 4:2 411 if not[ c in ['r','r','S','s','B','b','E','e','q','q','p','p']]
375 2 4:2 418 then write[chr(7)];
376 2 4:1 428 until ['q'=] or ['q'=];
377 2 4:1 441 ec_clr_screen;
378 2 1:0 0 end;
379 2 1:0 0 begin [voicelab]
380 2 1:0 0 repeat
381 2 1:1 0
382 2 1:2 0 c:=ec_prompt[concat('VoiceLab: D[ictionary, R[ecord',
383 2 1:2 17 ' & listen, E[statistics, M[essage, F[ilter, Q[uit '],
384 2 1:2 30 -1,0,0,
385 2 1:2 35 ['a','d','r','l','s','f','q','w','d','r','l','s','f','q',' '],
386 2 1:2 43 f:=ec[ , ];
387 2 1:2 50 case c of
388 2 1:2 53 ' ':ec_clr_screen;
389 2 1:2 57 'D','d':dictionary;
390 2 1:2 61 'R','r':record_listen;
391 2 1:2 65 'S','s':display;
392 2 1:2 68 'F','f':filter;
393 2 1:2 73 'M','m':message;
394 2 1:2 77 end;
395 2 1:1 80 until [C='q'] or [C='0'];
396 2 :0 0 end [voicelab].

```

End of Completion.

Listing 2: The Voice Dictionary unit (Voice_dictionary), which provides all speech-storage and speech-retrieval functions for Voice Lab.

Pascal Compiler IV.1 c5s-4 3/27/83

```

1 2 1:1d 1 Unit Voice_dictionary;
2 2 1:1d 1
3 2 1:1d 1 Interface
4 2 1:1d 1 [
5 2 1:1d 1 [
6 2 1:1d 1 [ VOICELAB VOCABULARY DICTIONARY
7 2 1:1d 1 [ MANAGEMENT UNIT
8 2 1:1d 1 [
9 2 1:1d 1 [ (C)opyright John E. Hoot 1983. ALL rights
10 2 1:1d 1 [ reserved
11 2 1:1d 1 [
12 2 1:1d 1 [
13 2 1:1d 1
14 2 1:1d 1 type dict_result=[successful,buf_oflow,not_found,
15 2 1:1d 1 dict_full,dup_entry,index_oflow];
16 2 1:1d 1
17 2 1:1d 1 function find_word[ name:string; var idx:integer ] : boolean;
18 2 1:1d 1
19 2 1:1d 1 function index_word{ idx:integer; var name:string;
20 2 1:1d 1 var lns:integer } : boolean;
21 2 1:1d 1
22 2 1:1d 1 function insert_words[ as:string ] : dict_result;
23 2 1:1d 1
24 2 1:1d 1 function append_word[ name:string ] : dict_result;
25 2 1:1d 1
26 2 1:1d 1 function remove_word[ name:string ] : dict_result;
27 2 1:1d 1
28 2 1:1d 1 procedure clear_dictionary;
29 2 1:1d 1
30 2 1:1d 1 Implementation
31 2 1:1d 1
Using ANALOGIO
32 2 1:1u 1 [
33 2 1:1u 1 [
34 2 1:1u 1 [ VOICELAB ANALOG INPUT/OUTPUT
35 2 1:1u 1 [ SERVICE UNIT
36 2 1:1u 1 [
37 2 1:1u 1 [
38 2 1:1u 1 [ (C)opyright John E. Hoot 1983. ALL rights
39 2 1:1u 1 [ reserved
40 2 1:1u 1 [
41 2 1:1u 1 [
42 2 1:1u 1 const vox_bufLen = 16383;
43 2 1:1u 1
44 2 1:1u 1 type vox_bufRange = 0..vox_bufLen;
45 2 1:1u 1 bytes = 0..255;
46 2 1:1u 1 vox_buf:=packed array[vox_bufRange] of bytes;
47 2 1:1u 1 vox_ptr = 'vox_buffer';
48 2 1:1u 1
49 2 1:1u 1 var tempo,start,stop:vox_bufRange;
50 2 1:1u 1 stream:vox_ptr;
51 2 1:1u 4
52 2 1:1u 5

```

Listing 2 continued on page 463

```

53 2 1:u 5
54 2 1:u 2
55 2 1:u 1
56 2 1:u 1
57 2 1:u 1
58 2 1:u 1
59 2 1:d 1
60 2 1:d 1
61 2 1:d 1
62 2 1:d 1
63 2 1:d 1
64 2 1:d 1
65 2 1:d 1
66 2 1:d 1
67 2 1:d 1
68 2 1:d 1
69 2 1:d 1
70 2 1:d 2
71 2 1:d 42
72 2 1:d 43
73 2 1:d 43
74 2 8:d 1
75 2 8:0 0
76 2 8:1 0
77 2 8:1 4
78 2 8:3 24
79 2 1:0 0
80 2 1:0 0
81 2 1:d 1
82 2 2:d 1
83 2 2:0 0
84 2 2:1 5
85 2 2:1 10
86 2 2:2 18
87 2 2:1 35
88 2 2:1 35
89 2 2:2 48
90 2 2:3 48
91 2 2:3 59
92 2 2:5 83
93 2 2:6 83
94 2 2:6 87
95 2 2:6 90
96 2 2:5 95
97 2 2:2 100
98 2 1:0 0
99 2 1:0 0
100 [commented '1']
101 2 1:d 1
102 2 3:0 0
103 2 3:1 0
104 2 3:1 2
105 2 3:2 18
106 2 3:3 26
107 2 3:4 28
108 2 3:4 31
109 2 3:4 35
110 2 3:3 37
111 2 1:0 0
112 2 1:0 0

procedure ADC( var ptr:vox_buffer;
  offset, len: integer; rate:integer );
var i,j,k,l,arc,ln:integer;
begin
  remove_words:=not_found;
  if find_word( name, i ) then
    begin
      while (i>1) and
        (dict^{i-1}.blk=dict^{i}.blk)
      do i:=i-1;
      j:=i;
      while dict^{j}.blk=dict^{j+1}.blk
      do j:=j+1;
      arc:=dict^{j}.blk;
      l:=arc-dict^{j+1}.blk;
      dict^{dict^{j}.blk}=dict^{j+1}.blk;
      while j<dict^{j}.blk
      do begin
        dict^{j}.word:=dict^{j+1}.word;
        dict^{j}.len:=dict^{j+1}.len;
        dict^{j}.blk:=dict^{j+1}.blk-1;
        j:=j+1;
      end;
      dict^{0}.blk:=dict^{0}.blk+l-j;
      k:=dict^{dict^{0}.blk}.blk;
      dummy:=blockwrite(l,dict^{4},0);
      ln:=4;
      while (arc-l)<k
      do begin
        if k-arc+l<4 then ln:=k-arc+l;
        dummy:=blockread(l,dict^{ln},arc);
        dummy:=blockwrite(l,dict^{ln},arc-l);
        arc:=arc+4;
      end;
      dummy:=blockread(l,dict^{4},0);
      remove_word:=successful;
      exit(remove_word);
    end;
  end;
end;

procedure clear_dictionary;
begin
  with dict^{0}
  do begin
    blk:=1;
    dict^{1}.blk:=4;
    dummy:=blockwrite(l,dict^{4},0);
  end;
end;

function insert_words( a:string ) : dict_result;
var i,j,k,next:integer;
    dup,first:boolean;
    name:string;
begin
  dup:=false;
  first:=true;

```

Listing 2 continued:

```

173 2 4:1 11      repeat
174 2 4:2 11      i:=1;
175 2 4:2 13      [RR-
176 2 4:2 13      while [(i<length(a)) and (a(i)<>',' )
177 2 4:2 26      do i:=i+1;
178 2 4:2 34      name:=copy(s,i,i-1);
179 2 4:2 50      if s<>' ' then delete(s,i,1);
180 2 4:2 66      upcase(name);
181 2 4:2 89      if length(name)>7 then
182 2 4:2 69      name:=copy(name,1,7);
183 2 4:3 76      if dict[0].blk<>1 then
184 2 4:2 90      begin
185 2 4:3 103      for i:=1 to dict[0].blk-1
186 2 4:4 103      do if name=dict[i].word then
187 2 4:4 114      begin
188 2 4:6 138      insert_words:=dup_entry;
189 2 4:7 143      if firsttime then exit(insert_words)
190 2 4:7 151      else dup:=true;
191 2 4:7 155      end;
192 2 4:6 155      if dict[0].blk>dict_size then
193 2 4:3 160      begin
194 2 4:2 180      insert_words:=index_of_low;
195 2 4:3 175      exit(insert_words);
196 2 4:4 178      end;
197 2 4:4 184      next:=dict[0].blk;
198 2 4:2 184      if not dup then
199 2 4:2 196      with dict[next]
200 2 4:4 200      do begin
201 2 4:6 211      len:=stop-start;
202 2 4:8 223      words:=name;
203 2 4:6 228      i:=(len+511) div 512;
204 2 4:6 241      if firsttime then
205 2 4:8 244      dummy:=blockwrite(lib,stream+[start],
206 2 4:8 258      i,blk);
207 2 4:8 269      if dummy<>1 then
208 2 4:8 273      begin
209 2 4:8 282      insert_words:=dict_full;
210 2 4:8 288      exit(insert_words);
211 2 4:8 293      end;
212 2 4:8 298      dict[next+i].blk:=blk+i;
213 2 4:0 277      end
214 2 4:8 302      else
215 2 4:8 302      begin
216 2 4:8 318      dict[next+i].blk:=blk;
217 2 4:7 300      end;
218 2 4:8 300      if length(name)>7 then
219 2 4:7 302      name:=copy(name,1,7);
220 2 4:8 302      if dict[0].blk:=next+i;
221 2 4:8 318      dummy:=blockwrite(lib,dict[4,0]);
222 2 4:7 328      end;
223 2 4:8 328      dup:=false;
224 2 4:5 342      firsttime:=false;
225 2 4:5 357      until e='';
226 2 4:8 357      insert_words:=successful;
227 2 4:2 357      end;
228 2 4:2 358      until e='';
229 2 4:1 361      insert_words:=successful;
230 2 4:1 372      end;
231 2 1:0 0
    
```

```

232 2 1:0 0      function append_word( name:string) : dict_result;
233 2 1:0 1      var i,j,k,next:integer;
234 2 5:0 1      begin
235 2 5:0 6      upcase(name);
236 2 5:1 10      if length(name)>7 then
237 2 5:1 10      name:=copy(name,1,7);
238 2 5:2 18      if dict[0].blk<>1 then
239 2 5:1 32      begin
240 2 5:2 47      for i:=1 to dict[0].blk-1
241 2 5:3 47      do if name=dict[i].word then
242 2 5:3 58      with dict[i]
243 2 5:5 82      do begin
244 2 5:5 81      if len+stop>(16383-511) then
245 2 5:7 82      begin
246 2 5:8 108      append_word:=buf_of_low;
247 2 5:8 108      exit(append_word);
248 2 5:8 111      end;
249 2 5:8 116      dummy:=blockread(lib,stream+[stop],
250 2 5:7 116      (len+511) div 512,blk);
251 2 5:7 130      stop:=stop+len;
252 2 5:7 148      append_word:=successful;
253 2 5:7 163      exit(append_word);
254 2 5:7 166      end;
255 2 5:6 171      append_word:=not_found;
256 2 5:2 176      end;
257 2 5:1 176      begin (voice_dictionary)
258 2 1:0 0      reset((lib,'voice.dict');
259 2 1:1 8      if fresult<>0 then
260 2 1:2 26      begin
261 2 1:3 28      dummy:=vermen(dict,1024);
262 2 1:3 38      clear_dictionary;
263 2 1:3 49      end;
264 2 1:2 51      else dummy:=vermen(dict,1024);
265 2 1:1 51      dummy:=blockread(lib,dict[4,0]);
266 2 1:1 63      verdisplay(dict,1024);
267 2 1:1 78      close(lib,lock);
268 2 1:1 87      end. (Voice dictionary)
269 2 1:0 0
    
```

End of Compilation.

Listing 3: The Voice Display (Voice_dsp) unit, which displays graphical information describing the contents of the speech buffer. It contains routines specific to the type of printer being used.

```

Pascal Compiler IV.1 c68-4      3/27/83

1 2 1:d 1 Unit Voice_dsp;
2 2 1:d 1
3 2 1:d 1 Interface
4 2 1:d 1 [
5 2 1:d 1 [
6 2 1:d 1 [ VOICELAB PCM SPEECH ANALYSIS UNIT ]
    
```



```

7  2 1:d 1 ( (Copyright John E. Hoot 1988. All rights )
8  2 1:d 1 ( reserved )
9  2 1:d 1 ( )
10 2 1:d 1 ( )
11 2 1:d 1 ( )
12 2 1:d 1 ( )
13 2 1:d 1 ( )
14 2 1:d 1 ( )
15 2 1:d 1 ( )
16 2 1:d 1 ( )
17 2 1:d 1 ( )

18 2 1:u 1
19 2 1:u 1
20 2 1:u 1
21 2 1:u 1 ( VOICELAB ANALOG INPUT/OUTPUT
22 2 1:u 1 ( SERVICE UNIT
23 2 1:u 1 ( )
24 2 1:u 1 ( Copyright John E. Hoot 1988. All rights )
25 2 1:u 1 ( reserved )
26 2 1:u 1 ( )
27 2 1:u 1 ( )
28 2 1:u 1 ( )
29 2 1:u 1 ( )
30 2 1:u 1 ( )
31 2 1:u 1 type vox_bufrange = 0..vox_buflen;
32 2 1:u 1 byte = 0..255;
33 2 1:u 1 vox_buffers=packed array[vox_bufrange] of byte;
34 2 1:u 1 vox_ptr = ^vox_buffer;
35 2 1:u 1
36 2 1:u 1 var tempo_start,stop:vox_bufrange;
37 2 1:u 4 stream:vox_ptr;
38 2 1:u 5
39 2 1:u 5 procedure ADC( var ptr:vox_buffer;
40 2 1:u 2 offset, lens:vox_bufrange; rates:integer );
41 2 1:u 1
42 2 1:u 1 procedure DAC( var ptr:vox_buffer;
43 2 1:u 1 offset, lens:vox_bufrange; rates:integer );
44 2 1:u 1
45 2 1:d 1 uses (8) analog_io.coda] analog_io;

Using SCREENOP
46 2 1:u 1
47 2 1:u 1 const
48 2 1:u 1 sc_fill_len = 11;
49 2 1:u 1 sc_sel = 13;
50 2 1:u 1
51 2 1:u 1 type
52 2 1:u 1 sc_cheat = set of char;
53 2 1:u 1 sc_misc_rec = packed record
54 2 1:u 1 height, width : 0..255;
55 2 1:u 1 can_break, slow, xy_crt, lc_crt,
56 2 1:u 1 can_upscroll, can_downscroll : boolean;
57 2 1:u 1 end;
58 2 1:u 1 sc_data_rec = packed record
59 2 1:u 1 month : 0..12;
60 2 1:u 1 day : 0..31;

```

Listing 3 continued:

```

121 2 2:d 1 [ ..... ]
122 2 2:d 1 [ Printer dependent code to set line spacing. ]
123 2 2:d 1 [ Arguments is in pixels. This version is for ]
124 2 2:d 1 [ the MCO. Requires rewriting for other printers. ]
125 2 2:d 1 [ ..... ]
126 2 3:d 1 var b:packed array[0..2] of char;
127 2 3:d 0 begin
128 2 3:d 0 [ common header for MCO ... MX100 ]
129 2 3:1 0 b[0]:=chr(27);
130 2 3:1 7 b[1]:='A';
131 2 3:1 15 b[2]:=chr(x);
132 2 3:1 22 writeln(6,b,3,12);
133 2 3:1 30 [ ..... ]
134 2 3:1 30 [ MX 80 version suffix ]
135 2 3:1 30 [ [ b[1]:='2'; ] ]
136 2 3:1 30 [ [ writeln(6,b,2); ] ]
137 2 3:1 30 [ ..... ]
138 2 2:d 0 end;
139 2 2:d 0
140 2 2:d 0 [MX+]
141 2 2:d 1 function mean:integer;
142 2 4:d 1 var i,j:integer;
143 2 4:d 3 val:real;
144 2 4:d 0 begin
145 2 4:1 4 val:=0;
146 2 4:1 8 for i:=start to stop
147 2 4:1 11 do val:=val+stream[i];
148 2 4:1 42 mean:=trunc(val/(stop-start));
149 2 2:d 0 end;
150 2 2:d 0
151 2 2:d 0 [ ..... ]
152 2 2:d 0 [ ..... ]
153 2 2:d 0 [ VOICELAB PCM SPEECH ENERGY PLOT ]
154 2 2:d 0 [ ..... ]
155 2 2:d 0 [ PROCEDURE ]
156 2 2:d 0 [ [Copyright] John E. Hoot 1983. All rights ]
157 2 2:d 0 [ reserved ]
158 2 2:d 0 [ ..... ]
159 2 2:d 0 [ ..... ]
160 2 2:d 1 procedure energy;
161 2 5:d 1 var delta,avg,vel:integer;
162 2 5:d 4 cr,c:char;
163 2 5:d 6 i,j,last,next,lo,hi:integer;
164 2 5:d 12 next_cross, last_cross, cross:integer;
165 2 5:d 15 print:boolean;
166 2 5:d 16 i:string;
167 2 5:d 57 f:text;
168 2 5:1 13 begin
169 2 5:1 15 ec_clr_screen;
170 2 5:1 15 repeat
171 2 5:1 15 cs:=c_prompt[
172 2 5:1 15 'Energy (==) & Crossings (...) so: Plrinters, D[isplay ',
173 2 5:1 21 '-1,0,0,0,{'p','d','p','d'},false,1)];
174 2 5:1 40 writeln;
175 2 5:1 47 print:=false;
176 2 5:1 50 if [c='p'] or [c='P'] then
177 2 5:1 61 begin
178 2 5:1 61 rewrite(fr,'printers');
179 2 5:1 74 print:=true;

```

```

180 2 5:4 77 writeln(fr);
181 2 5:4 83 writeln(fr);
182 2 5:4 89 writeln(fr);
183 2 5:4 95 writeln(fr);
184 2 5:4 101 writeln(fr,'Energy: == ');
185 2 5:4 118 writeln(fr,'Zero Crossings: ...');
186 2 5:1 137 end;
187 2 5:1 137 until c in ['p','P','D','d'];
188 2 5:1 148 if print then pitch(4);
189 2 5:1 154 val:=0;
190 2 5:1 156 cross:=0;
191 2 5:1 158 [#R-
192 2 5:1 158 a[0]:=chr(70);
193 2 5:1 165 [#R+
194 2 5:1 165 next_cross:=1;
195 2 5:1 167 avg:=stream-[start]*100;
196 2 5:1 170 cr:=chr(13);
197 2 5:1 186 for i:=start to stop
198 2 5:1 188 do begin
199 2 5:1 181 delta:=avg div 100;
200 2 5:3 207 avg:=stream-[i]*avg-delta;
201 2 5:3 212 if delta<stream[i] then
202 2 5:4 241 val:=val+(stream[i]-delta)
203 2 5:3 254 else val:=val+(delta-stream[i]);
204 2 5:3 273 if [stream[i]-delta]>[stream[i+1]-delta]<0 then
205 2 5:4 303 cross:=cross+1;
206 2 5:3 307 if [i-start] mod 50 = 48
207 2 5:3 318 then
208 2 5:4 325 fillchar(a[1],70,' ');
209 2 5:5 325 last:=next;
210 2 5:5 338 next:=val div 76;
211 2 5:5 346 if [next<3] then next_cross:=0
212 2 5:5 361 else next_cross:=cross*2;
213 2 5:5 361 if next_cross=0 then next_cross:=1;
214 2 5:5 368 if last_cross>next_cross then
215 2 5:6 373 begin
216 2 5:7 373 lo:=next_cross;
217 2 5:6 377 hi:=last_cross;
218 2 5:6 377 and
219 2 5:6 377 else
220 2 5:6 378 begin
221 2 5:6 379 lo:=last_cross;
222 2 5:7 381 hi:=next_cross;
223 2 5:6 383 and;
224 2 5:6 383 fillchar(s[lo],hi-lo,' ');
225 2 5:6 384 s[next_cross]:=',';
226 2 5:6 404 if print then
227 2 5:7 404 begin
228 2 5:7 416 write(fr,' ');
229 2 5:7 447 writeln(6,cr,1,12);
230 2 5:6 455 and;
231 2 5:6 465 if print then fillchar(a[1],70,' ');
232 2 5:6 468 if next=0 then next:=1;
233 2 5:6 474 if next>55 then next:=55;
234 2 5:6 483 if last=next then
235 2 5:7 488 begin
236 2 5:6 488 lo:=next;
237 2 5:6 488
238 2 5:6 488
239 2 5:6 488
240 2 5:7 488

```



```

480 2 2:2 2      ci:=sc_prompt[
481 2 2:2 3      concat( 'State: E[nergy & Crosses, P[lot,',
482 2 2:2 18      ' A]vg, M]ax&min, S]pect, Q]uit '),
483 2 2:2 31      -1,0,0,0,{'p','e','a','m','s','q','P','E','A','M','S','Q',' '},
484 2 2:2 44      FALSE,'');
485 2 2:2 50      case c of
486 2 2:2 54      ' :sc_clr_screen;
487 2 2:2 58      'A','e':begin
488 2 2:4 59          writeln;
489 2 2:4 66          writeln('Computing...');
490 2 2:4 86          write('Mean value from ',start,' to ',stop,
491 2 2:4 134          ' is ',mean);
492 2 2:3 158          end;
493 2 2:2 161      'M','m':begin
494 2 2:4 161          writeln;
495 2 2:4 168          sc_clr_cur_line;
496 2 2:4 170          writeln('Computing...');
497 2 2:4 180          max:=0;
498 2 2:4 182          min:=255;
499 2 2:4 185          for i:=start to stop-1
500 2 2:4 201              do begin
501 2 2:6 211                  if stream[i]>max then max:=stream[i];
502 2 2:6 236                  if stream[i]<min then min:=stream[i];
503 2 2:5 261                  end;
504 2 2:4 266                  writeln;
505 2 2:4 273                  writeln('Max from ',start,' to ',stop,' is ',
506 2 2:4 334                  max,'. ');
507 2 2:4 360                  writeln('Min from ',start,' to ',stop,' is ',
508 2 2:4 421                  min,'. ');
509 2 2:3 447                  end;
510 2 2:2 448          'E','e':Energy;
511 2 2:2 453          'P','p':plot;
512 2 2:2 457          'S','s':Spectrum;
513 2 2:2 461          end;
514 2 2:1 464      until (c='Q') or (c='q');
515 2 1:0 0      end;
516 2 1:0 0
517 2 1:0 0      end [voice_dsp].

```

End of Compilation.

S(et Tempo 39
B(eginning 0
E(nd 0
R(ecord
P(lay
Q(uit

Figure 6: Menu screen for the Record and Listen routine.

Text continued from page 457:

Upon your selecting the Energy and Crosses plot, the program asks whether the plot is to be routed to the printer or to the video display. Once a selection is made, the program begins to produce graphs like those in figure 4 in Part 1 of this article (July, pages 202 and 203), which are graphs of the spectral energy and number of zero-crossings contained in the signal. You can abort the plot before it reaches the End index in the speech by pressing any character on the keyboard.

When you select Plot, the program asks whether the plot is to be routed to the printer or to the display. Once a selection is made, the program begins to print or display graphs like

those in figure 3 from last month (page 198). This plot, too, can be stopped by pressing any character on the keyboard.

The statistics menu also contains functions to compute three useful scalar values: the maximum waveform peak, the minimum waveform peak, and the average (DC—direct current) bias of the speech-buffer segment. These values are useful primarily in calibrating the input signal level. The optimal signal parameters for a properly calibrated amplifier for voiced input speech are:

Maximum Signal	254
Minimum Signal	1
Average Value	127

You'll rarely attain these values exactly, but grossly underdriving the A/D converter or setting excessive DC-offset values can badly distort digital speech's intelligibility and introduce errors into Voice Lab's analysis computations.

When you select the Spectrum option, the program gives you the

choice of routing output to the printer or to the display. Once you've made your selection, the program begins to produce graphs like those in figure 5 in part 1 (pp. 202 and 203). As above, this plot can be stopped by pressing any character on the keyboard.

Both the spectrum-analysis and the waveform plots take some time to generate. So that the program may run as fast a possible, the code in the Voice Display unit has native-code directives bracketing these sections. In some implementations of the UCSD p-System, such as the one for the IBM Personal Computer, it is possible to send the program's p-code (pseudocode) object file through a native-code generator. This will translate the indicated section of the program to machine instructions directly executable by the microprocessor. As a result, the computation time in this section will be dramatically reduced, while other, noncritical sections of the program are left in the more compact p-code representation. Just remember that producing native code for the Voice Display unit will render its object code incompatible with p-Systems running on different processors.

Messages Menu

The Messages menu contains just these choices:

Messages:
L(iteral
F(ile
Q(uit

It allows you to have the word-list-based speech-synthesis functions in Voice Lab read back to you files or strings that you have keyed in. If you select Literal input, the program begins prompting you for input lines. After the line has been entered, it is passed to the speech synthesizer in the Voice Message unit (listing 4). It will continue prompting for additional lines until a blank line is entered. If you use the File option, specifying the name of an existing file, the program reads the file one line at a time and passes the text in it to the speech synthesizer.

Digital Filter: term <0.5>, D)c offset, F)lter, Q)uit

Formula Coefficients: W(eight, D(elay, Q(uit

Formula X[T] =
0.50 * x[t] + 0.50 * x[t + 1] + 5

Term	Delay	Weight
0)	0t	0.50
1)	1t	0.50
2)	0t	0.00
3)	0t	0.00
4)	0t	0.00
5)	0t	0.00

D)c Offset: 5

Figure 7: Sample screen display produced by the filter routine.

Formula X[T] =
0.50 * x[t] + 0.50 * x[t - 1]

Term	Delay	Weight
0)	0t	0.50
--> 1)	1t	0.50
2)	0t	0.00
3)	0t	0.00
4)	0t	0.00
5)	0t	0.00

D)c Offset: 0

Figure 8: Sample coefficient-modifying screen in the filter routine.

Filter Menu

When the digital-filter option is selected, a screen similar to that in figure 7 is displayed. This screen displays the options available across the top line, along with the current difference equation and a table of terms. If the formula indicates the operation you wish to perform, press "F" to begin filtering. The program will make one pass through the speech buffer, from beginning to end, applying the indicated formula. The message:

Computing

will be displayed across the bottom

of the display. For each 50 samples processed another period is displayed so you can watch the progress.

This operation, like the plots, can take a long time, particularly if you have specified a very complex polynomial. Like the plotting unit, the Voice Filter unit (listing 5) contains the compiler directives that will allow you to generate native code to perform the computation and improve the system's performance.

To modify the difference equation used in filtering the contents of the speech buffer, type the number corresponding to the equation term you wish to edit. When you do this, the screen will change to appear as

shown in figure 8. You can modify both the weight and delay values in the equation. The DC-offset value can be changed only from the primary edit screen. When the selected term has been set to your satisfaction, you can return to the primary filter screen by selecting Quit. This process can be repeated indefinitely until all the terms of the equation have been set.

Multistage filtering can be achieved by repeatedly filtering the same speech-buffer segment. Recursive or closed-loop filters (those with feedback and oscillators) can be simulated by using negative delay values. When using a recursive filter, take care to make sure it is stable.

Text continued on page 475

a message to our subscribers

From time to time we make the BYTE subscriber list available to other companies who wish to send our subscribers material about their products. We take great care to screen these companies, choosing only those who are reputable, and whose products, services, or information we feel would be of interest to you. Direct mail is an efficient medium for presenting the latest personal computer goods and services to our subscribers.

Many BYTE subscribers appreciate this controlled use of our mailing list, and look forward to finding information of interest to them in the mail. Used are our subscribers' names and addresses only (no other information we may have is ever given).

While we believe the distribution of this information is of benefit to our subscribers, we firmly respect the wishes of any subscriber who does not want to receive such promotional literature. Should you wish to restrict the use of your name, simply send your request to the following address.

BYTE Publications Inc
Attn: Circulation Department
70 Main St
Peterborough NH
03458

Listing 4: The Voice Messages (Voice_msg) unit, which converts text represented by ASCII characters into audible speech.

Pascal Compiler IV.1 c6e-4 3/27/83

```

1 2 1:d 1 Unit Voice_msg;
2 2 1:d 1
3 4 2 1:d 1 Interface
4 2 1:d 1 (-----)
5 2 1:d 1 (
6 2 1:d 1 ( VOICELAB TEXT-TO-SPEECH OUTPUT
7 2 1:d 1 ( SERVICE UNIT
8 2 1:d 1 (
9 2 1:d 1 ( [Copyright John E. Hoot 1983. All rights
10 2 1:d 1 ( reserved
11 2 1:d 1 (
12 2 1:d 1 (-----)
13 2 1:d 1
14 2 1:d 1 function speakword( sstring ): boolean;
15 2 1:d 1 procedure speakline( lstring );
16 2 1:d 1
17 2 1:d 1 Implementation
18 2 1:d

Using ANALOGIO
19 2 1:u
20 2 1:u
21 2 1:u
22 2 1:u ( VOICELAB ANALOG INPUT/OUTPUT
23 2 1:u ( SERVICE UNIT
24 2 1:u (
25 2 1:u ( [Copyright John E. Hoot 1983. All rights
26 2 1:u ( reserved
27 2 1:u (
28 2 1:u (-----)
29 2 1:u
30 2 1:u const vox_bufLen = 16383;
31 2 1:u
32 2 1:u type vox_bufRange = 0..vox_bufLen;
33 2 1:u byte = 0..255;
34 2 1:u vox_bufRange = packed array[vox_bufRange] of byte;
35 2 1:u vox_ptr = ^vox_bufRange;
36 2 1:u
37 2 1:u var tempo_start, stop_vox_bufRange;
38 2 1:u stream_vox_ptr;
39 2 1:u
40 2 1:u procedure ADC( var ptr_vox_bufRange;
41 2 1:u offset, len: vox_bufRange; retas: integer );
42 2 1:u
43 2 1:u procedure DAC( var ptr_vox_bufRange;
44 2 1:u offset, len: vox_bufRange; retas: integer );
45 2 1:u
46 2 1:d 1 uses [ @ analog_io.code ] analog_io;
47 2 1:u
48 2 1:u Using VOICEDIC
49 2 1:u (
50 2 1:u ( VOICELAB VOCABULARY DICTIONARY
51 2 1:u ( MANAGEMENT UNIT
52 2 1:u (
53 2 1:u ( [Copyright John E. Hoot 1983. All rights
54 2 1:u ( reserved
55 2 1:u (
56 2 1:u (-----)
57 2 1:u
58 2 1:u type dict_result = [ successful, buf_overflow, not_found,
59 2 1:u dict_full, dup_entry, index_overflow ];
60 2 1:u
61 2 1:u function find_word( namestring; var idx: integer ): boolean;
62 2 1:u
63 2 1:u function index_word( idx: integer; var namestring;
64 2 1:u var ln: integer ): boolean;
65 2 1:u
66 2 1:u function insert_words( sstring ): dict_result;
67 2 1:u
68 2 1:u function append_word( namestring ): dict_result;
69 2 1:u
70 2 1:u function remove_word( namestring ): dict_result;
71 2 1:u
72 2 1:u procedure clear_dictionary;
73 2 1:u
74 2 1:d 1 [ @ voice.dict.code ] voice_dictionary;
75 2 1:u
76 2 1:d
77 2 1:d var
78 2 1:d result: dict_result;
79 2 1:d dummy: integer;
80 2 1:d sstring;
81 2 1:d cchar;
82 2 1:d
83 2 1:d function speakword( sstring ): boolean;
84 2 2:d 0
85 2 2:d 1 begin
86 2 2:d 1 start:=0;
87 2 2:d 1 stop:=0;
88 2 2:d 1 result:=append_word(s);
89 2 2:d 1 if result=successful then
90 2 2:d 1 begin
91 2 2:d 1 speakword:=true;
92 2 2:d 1 dec(stream^start, stop, tempo);
93 2 2:d 1 and
94 2 1:d 0 else speakword:=false;
95 2 1:d 0 end;
96 2 1:d 1 procedure speakline( lstring );
97 2 3:d 1 var i, j: integer;
98 2 3:d 4 namestring[7];
99 2 3:d 8 wordstring[6];
100 2 3:d 13 [ @ - ]
101 2 3:d 0 begin
102 2 3:d 1 for i:=1 to length(ln)
103 2 3:d 14 do if (ln[i]<='z') and (ln[i]>='a') then
104 2 3:d 41 ln[i]:=chr(ord(ln[i])-92);
105 2 3:d 58 i:=i;
106 2 3:d 81 while i<= length(ln)
107 2 3:d 67 do begin
108 2 3:d 71 j:=0;
109 2 3:d 73 while (length(ln)>=i) and (ln[i]=' ')
110 2 3:d 88 do i:=i+1;

```

```

111 2 3:3 96
112 2 3:3 111
113 2 3:3 120
114 2 3:5 123
115 2 3:5 128
116 2 3:4 129
117 2 3:3 131
118 2 3:4 136
119 2 3:5 136
120 2 3:6 166
121 2 3:6 157
122 2 3:8 167
123 2 3:4 236
124 2 3:3 236
125 2 3:4 237
126 2 3:5 237
127 2 3:6 257
128 2 3:6 258
129 2 3:8 288
130 2 3:4 336
131 2 3:3 338
132 2 3:3 352
133 2 3:3 360
134 2 3:5 364
135 2 3:5 371
136 2 3:5 380
137 2 3:5 388
138 2 3:5 388
139 2 3:5 407
140 2 3:5 418
141 2 3:5 425
142 2 3:5 434
143 2 3:5 443
144 2 3:5 452
145 2 3:5 461
146 2 3:5 484
147 2 3:6 471
148 2 3:5 504
149 2 3:4 507
150 2 3:3 510
151 2 3:3 517
152 2 3:3 534
153 2 3:3 553
154 2 3:5 556
155 2 3:5 574
156 2 3:4 577
157 2 3:2 578
158 2 1:0 0
159 2 1:0 0
160 2 :0 0
    
```

End of Compilation.

Listing 5: The Voice Filtering unit (Voice_filter), which can perform many kinds of digital filtration on the contents of the speech buffer.

Pascal Compiler IV.1 c58-4 3/27/83

```

1 2 1:0 1 Unit Voice_filter;
2 2 1:0 1
3 2 1:0 1 Interface
4 2 1:0 1 [-----]
5 2 1:0 1 [
6 2 1:0 1 [ VOICELAB PCM SPEECH RECURSIVE DIGITAL
7 2 1:0 1 [ FILTERING UNIT
8 2 1:0 1 [
9 2 1:0 1 [ (C)opyright John E. Hoot 1983. All rights
10 2 1:0 1 [ reserved
11 2 1:0 1 [
12 2 1:0 1 [-----]
13 2 1:0 1 procedure filter;
14 2 1:0 1
15 2 1:0 1 implementation
16 2 1:0 1
17 2 1:0 1

Using ANALOGIO
18 2 1:0 1
19 2 1:0 1 [-----]
20 2 1:0 1 [ VOICELAB ANALOG INPUT/OUTPUT
21 2 1:0 1 [ SERVICE UNIT
22 2 1:0 1 [
23 2 1:0 1 [
24 2 1:0 1 [ (C)opyright John E. Hoot 1983. All rights
25 2 1:0 1 [ reserved
26 2 1:0 1 [
27 2 1:0 1 [-----]
28 2 1:0 1 const vox_bufLen = 16383;
29 2 1:0 1
30 2 1:0 1 type vox_bufRange = 0..vox_bufLen;
31 2 1:0 1 byte = 0..255;
32 2 1:0 1 vox_buf = packed array[vox_bufRange] of byte;
33 2 1:0 1 vox_ptr = ^vox_buf;
34 2 1:0 1
35 2 1:0 1 var tempo_start, stop: vox_bufRange;
36 2 1:0 1 stream: vox_ptr;
37 2 1:0 4
38 2 1:0 5 procedure ADC( var ptr: vox_buf;
39 2 1:0 2 offset, len: vox_bufRange; rate: integer );
40 2 1:0 2
41 2 1:0 1
42 2 1:0 1 procedure DAC( var ptr: vox_buf;
43 2 1:0 1 offset, len: vox_bufRange; rate: integer );
44 2 1:0 1
45 2 1:0 1 uses ( $U analog_io.code ) analog_io,
Using SCREENOP
46 2 1:0 1
47 2 1:0 1 const
48 2 1:0 1 ec_fill_len = 11;
    
```

```

49 2 11u 1  sc_sol = 13;
50 2 11u 1
51 2 11u 1  type
52 2 11u 1  sc_cheat
53 2 11u 1  sc_misc_rec
54 2 11u 1  height, width : 0..255;
55 2 11u 1  can_break, slow, xy_crt, lc_crt,
56 2 11u 1  can_upscroll, can_downscroll : boolean;
57 2 11u 1  and;
58 2 11u 1  sc_date_rec = packed record
59 2 11u 1  month : 0..12;
60 2 11u 1  day : 0..31;
61 2 11u 1  year : 0..99;
62 2 11u 1  and;
63 2 11u 1  sc_info_type = packed record
64 2 11u 1  sc_version : string;
65 2 11u 1  sc_date : sc_date_rec;
66 2 11u 1  spec_char : sc_cheat; {Characters not to echo}
67 2 11u 1  misc_info : sc_misc_rec;
68 2 11u 1  and;
69 2 11u 1  sc_long_string = string[255];
70 2 11u 1  sc_scrn_command = [sc_home, sc_erase_s, sc_erase_sol, sc_clear_line,
71 2 11u 1  sc_clear_scn, sc_up_cursor, sc_down_cursor,
72 2 11u 1  sc_left_cursor, sc_right_cursor];
73 2 11u 1  sc_key_command = [sc_backspace_key, sc_del_key, sc_eof_key, sc_esc_key,
74 2 11u 1  sc_escape_key, sc_del_key, sc_up_key, sc_down_key,
75 2 11u 1  sc_left_key, sc_right_key, sc_not_legal];
76 2 11u 1  sc_choice = [sc_get, sc_give];
77 2 11u 1  sc_window = packed array [0..0] of char;
78 2 11u 1  sc_tx_port = record
79 2 11u 1  row, col, [ screen relative]
80 2 11u 1  height, width, [ size of txport (zero based)]
81 2 11u 1  cur_x, cur_y : integer;
82 2 11u 1  {cursor positions relative to the txport }
83 2 11u 1  and;
84 2 11u 1
85 2 11u 1  procedure sc_use_info(do_what:sc_choice; var t_info:sc_info_type);
86 2 11u 1  procedure sc_erase_to_sol(x,line:integer);
87 2 11u 1  procedure sc_left;
88 2 11u 1  procedure sc_right;
89 2 11u 1  procedure sc_up;
90 2 11u 1  procedure sc_down;
91 2 11u 1  procedure sc_get_ch(var ch:char; return_on_match:sc_cheat);
92 2 11u 1  procedure sc_clr_screen;
93 2 11u 1  procedure sc_clr_line (y:integer);
94 2 11u 1  procedure sc_home;
95 2 11u 1  procedure sc_erase(x,line:integer);
96 2 11u 1  procedure sc_get_xy(x,line:integer);
97 2 11u 1  procedure sc_clr_cur_line;
98 2 11u 1  function sc_find_x:integer;
99 2 11u 1  function sc_find_y:integer;
100 2 11u 1  function sc_scrn_has(what:sc_scrn_command):boolean;
101 2 11u 1  function sc_has_key(what:sc_key_command):boolean;
102 2 11u 1  function sc_ap_crt_command(var k:char):sc_key_command;
103 2 11u 1  function sc_prompt(line:sc_long_string; x_cursor,y_cursor,x_pos,
104 2 11u 1  where:integer; return_on_match:sc_cheat);
105 2 11u 1

```

```

106 2 11u 21
107 2 11u 1  function sc_check_char(var buf:sc_window; var buf_index,byte_left:integer);
108 2 11u 1  boolean;
109 2 11u 1  function space_waits(flush:boolean):boolean;
110 2 11u 1  procedure sc_init;
111 2 11u 1  [8U screenops.code] screen_ops;
112 2 11d 1
113 2 11d 1  const last_line = 23;
114 2 11d 1
115 2 11d 1  type equation =
116 2 11d 1  record
117 2 11d 1  terms:array[0..5] of
118 2 11d 1  record
119 2 11d 1  delay: integer;
120 2 11d 1  weight: real;
121 2 11d 1  signal: real;
122 2 11d 1  and;
123 2 11d 1  dc_offset:integer;
124 2 11d 1  and;
125 2 11d 1  var i:integer;
126 2 11d 1  var i:integer;
127 2 11d 1  var i:integer;
128 2 11d 2  formula:equation;
129 2 11d 57
130 2 11d 57  procedure filter;
131 2 21d 1  var i,j:integer;
132 2 21d 3  c:char;
133 2 21d 4  term_tot:real;
134 2 21d 8
135 2 21d 8  procedure scheme;
136 2 31d 1  var first_term:boolean;
137 2 31d 0  begin
138 2 31d 0  sc_clr_line(5);
139 2 31d 3  writeln('Formula: X[T] = ');
140 2 31d 23  write(' ');
141 2 31d 38  first_term:=true;
142 2 31d 38  for i:=0 to 5
143 2 31d 38  do with formula.term[i]
144 2 31d 58  begin
145 2 31d 88  if (not first_term) and (weight>0)
146 2 31d 78  then write('+');
147 2 31d 78  write(weights[i]*x[i]);
148 2 31d 92  if delay>0 then write('-',delay);
149 2 31d 118  write(' ');
150 2 31d 144  first_term:=false;
151 2 31d 157  and;
152 2 31d 158  if formula.dc_offset>0 then
153 2 31d 167  write('+',formula.dc_offset);
154 2 31d 176  if formula.dc_offset<0 then
155 2 31d 200  write('-',formula.dc_offset);
156 2 31d 208  writeln;
157 2 31d 234  end;
158 2 21d 0
159 2 21d 0  procedure terms( idx:integer);
160 2 21d 0  var c:char;
161 2 21d 1  begin
162 2 41d 1  repeat
163 2 41d 0  begin
164 2 41d 1  repeat

```

Listing 6: The Analog-I/O unit (Analog_I/O), a hardware-specific unit that reads data from the analog-to-digital converter and writes data to the digital-to-analog converter.

Pascal Compiler IV.1 c56-4 3/27/83

```

1 2 1:d 1 UNIT ANALOG_IO;
2 2 1:d 1
3 2 1:d 1 Interface
4 2 1:d 1 [-----]
5 2 1:d 1 [
6 2 1:d 1 [ VOICELAB ANALOG INPUT/OUTPUT ]
7 2 1:d 1 [ SERVICE UNIT ]
8 2 1:d 1 [
9 2 1:d 1 [ [C]opyright John E. Hoot 1983. All rights ]
10 2 1:d 1 [ reserved ]
11 2 1:d 1 [
12 2 1:d 1 [-----]
13 2 1:d 1
14 2 1:d 1 const vox_buflen = 16383;
15 2 1:d 1
16 2 1:d 1 type vox_bufrange = 0..vox_buflen;
17 2 1:d 1 byte = 0..255;
18 2 1:d 1 vox_buffer:=packed array[vox_bufrange] of byte;
19 2 1:d 1 vox_ptr = ^vox_buffer;
20 2 1:d 1
21 2 1:d 1 var tempo,start,stop:vox_bufrange;
22 2 1:d 4 stream:vox_ptr;
23 2 1:d 5
24 2 1:d 5 procedure ADC( var ptr:vox_buffer;
25 2 1:d 2 offset, len: vox_bufrange; rate:integer );
26 2 1:d 1
27 2 1:d 1 procedure DAC( var ptr:vox_buffer;
28 2 1:d 2 offset, len:vox_bufrange; rate:integer );
29 2 1:d 1
30 2 1:d 1 Implementation
31 2 1:d 1
32 2 1:d 1
33 2 1:d 1 procedure sample( var ptr:vox_buffer; offset, len: vox_bufrange );
34 2 1:d 1 external;
35 2 1:d 1
36 2 1:d 1 procedure play( var ptr:vox_buffer; offset, len, rate:vox_bufrange);
37 2 1:d 1 external;
38 2 1:d 1
39 2 1:d 1 procedure ADC;
40 2 2:0 0 begin
41 2 2:1 0 sample( ptr,offset,len );
42 2 1:0 0 end;
43 2 1:0 0
44 2 1:d 1 procedure DAC;
45 2 3:0 0 begin
46 2 3:1 0 play( ptr, offset, len, rate );
47 2 1:0 0 end;
48 2 1:0 0
49 2 1:0 0 begin
50 2 1:1 0 new(stream);
51 2 1:1 7 start:=0;
52 2 1:1 15 stop:=0;
53 2 1:1 23 tempo:=39;
54 2 1:1 32 ***;
55 2 1:1 34 dispose(stream);
56 2 :0 0 end.

```

Text continued from page 470:

Installation and Adaptation

The Voice Lab program and units were developed in UCSD Pascal under version IV of the p-System (distributed by Softech Microsystems) and operate most effectively under that version of the system. Voice Lab relies strongly on the p-System's modular unit philosophy, so adapting Voice Lab to another operating environment would not be a simple task.

To get Voice Lab to run under Apple Pascal version 1.1, you must relink the units after each modification, which makes for slow work. Additionally, the virtual-memory management under the version IV p-System allows Voice Lab to operate with a larger speech buffer on an Apple than does Apple Pascal 1.1.

Voice Lab is designed to be portable to various computers in both source and object code. With two exceptions,

the object code for the main program and all the units can be moved from machine to machine without recompilation. I have successfully transported Voice Lab between the IBM Personal Computer and the Apple II. The two exceptions to portability are the printer-output routine and the Analog I/O unit.

The Analog I/O unit (listing 6) performs the actual digitizing of the speech input and synthesis of the speech output. The specific characteristics of the hardware interface to the D/A and A/D converters will inevitably differ from machine to machine. To accommodate this situation, the Analog I/O unit is structured to require that two assembly-language procedures, Sample and Play, be linked into it.

The Sample procedure reads the computer's analog input at a rate determined by one of its calling arguments. Each sample is assumed to be an 8-bit unsigned number in the range 0 through 255, and the quiescent value of the input should be 127 or 128. The samples should be written to memory beginning at the location indicated by the sum of two other arguments shown in listing 6, the Offset and the Ptr base address. Sampling should continue until the number of samples specified by the Len argument have been accumulated. At that time, the Sample procedure should return control to Analog I/O.

The Play procedure performs the inverse operation to Sample. All arguments to Play are interpreted in the same fashion as Sample, except values are read from memory and written to the D/A converter.

The only other area of Voice Lab that may require modification is the printer-output section in the Voice Display unit. The Voice Display unit, as shown in listing 3, is designed to operate with an Epson MX-70 printer. The lines of source code specific to the MX-70 are demarcated by comments; these will have to be rewritten if you have a different printer.

The waveform-routine is designed to operate with dot-matrix graphics. If your computer does not support dot-matrix graphical output, you can

use hyphens or microspaced periods to generate the graphical output, but producing the output will take a long time. If hyphens are used, the same algorithm that is used on the display can be applied to the printer.

These modifications should not be hard, as such things go, so after just a little time modifying the print routines and adapting to your D/A and A/D hardware, you should be ready to begin investigating digital speech synthesis and analysis with Voice Lab.

Conclusions

Voice Lab provides a workbench upon which the structure of speech can be analyzed and offers a library of system units that facilitate speech synthesis from application programs.

Voice Lab is neither a static nor a completed project. Its modular-unit structure is specifically designed to allow experimentation and further development. In the project's gestative phases, versions of the Voice Lab library have used ADPCM, (adaptive differential pulse-code

modulation), DPCM, and PCM encoding. And at one point the Voice Messages unit employed a phonetic, rather than word-oriented vocabulary.

I'm still working on extensions to handle common word endings, such as plurals. Additionally, the results from the zero-crossing analysis and peak-energy plots have suggested some reasonable lines of inquiry into speech recognition, the other side of the voice-input/output problem.

I hope that I've encouraged you to push the limits of your computer and discover the frontiers of speech interaction. ■

References

1. Anderson, James C. "An Extremely Low-Cost Computer Voice Response System." BYTE, February 1981, page 36.
2. Ciarcia, Steve. "Talk to Me! Add a Voice to Your Computer for \$35." BYTE, June 1978, page 142.
3. Ciarcia, Steve. "Use ADPCM for Highly Intelligible Speech Synthesis." BYTE, June 1983, page 35.
4. Ciarcia, Steve. "Use Voiceprints to Analyze Speech." BYTE, March 1982, page 50.

5. Flanagan, J. L. *Speech Analysis, Synthesis, and Perception*, second revised edition. New York: Springer-Verlag, 1972.
6. Flanagan, J. L. "Voices of Men and Machines." *Journal of the Acoustical Society of America*. Volume 51, March 1972, page 1375.
7. Hoot, John E. "Voice Lab: A System for Digital Speech Synthesis and Analysis, Part 1." BYTE, July 1983, page 186.
8. Mazor, Stan. "Approaching Filtering Discretely." *Computer Design*, April 1982, page 159.
9. O'Haver, Tom. "Audio Processing with a Microcomputer." BYTE, June 1978, page 166.
10. Payne, Robert A. "A Voice for the Apple II Without Extra Hardware." BYTE, November 1981, page 499.
11. Schafer, Lawrence R. and Ronald W. Schafer. "Digital Representations of Speech Signals." *Proceedings of the IEEE*, Volume 63, April 1975, page 662.
12. *22920 Analog Signal Processor Design Handbook*. Santa Clara, CA: Intel Corporation, 1980.

John E. Hoot is president of Software & Systems Consulting (4181 Bryan St., Oceanside, CA 92056) and former manager of product software development for Softech Microsystems. His firm specializes in p-System adaptations, application development, and marketing.

ADALAB™ Automates Lab Instruments



For Less Than
\$3400*

- Interactive Microware's general-purpose ADALAB™ data acquisition and control system interfaces with virtually any lab instrument using a recorder or meter, including GC and HPLC systems, spectrophotometers, pH meters, process control apparatus, thermocouples, etc.

- Lab Data Manager™ software facilitates single or multi-channel acquisition, storage, display and chart recorder style output of lab instrument data. IMI QUICKI/O software operates within easy-to-use BASIC!

- Thousands of scientists currently use IMI software and/or ADALAB products worldwide!

*Price includes 48K APPLE II+ CPU, disk drive with controller, 12" monitor, dot matrix printer with interface, IMI-ADALAB™ interface card.

†Trademark of Apple Computer, Inc.



IMI's ADALAB INTERFACE CARD IS AVAILABLE SEPARATELY FOR ONLY \$495

(Includes 12-bit A/D, 12-bit D/A, 8 digital sense inputs, 8 digital control outputs, 32-bit real-time clock, two 16-bit timers plus QUICKI/O data acquisition software.)



INTERACTIVE MICROWARE, INC.
P.O. Box 771, Dept. 3
State College, PA 16801 (814) 238-8294

WHY PAY RETAIL? AUGUST SPECIALS

AMDEK		ZENITH	
COLOR I MONITOR	\$281	Z-29 TERMINAL	\$676
COLOR II MONITOR	\$412	ZVM 121 MONITOR	\$83
300A MONITOR	\$145	ZVM 134 RGB	\$424
NEC Printers		(Includes IBM Cable)	
PC8023A	\$393	ZVM 122 AMBER	\$113
3550	\$1845	ZVM 123 AMBER	\$97
2050	CALL	ZVM 131 RGB	\$301
STAR Micronics Printers		ZVM 135 RGB	\$515
GEMINI 10X	\$308	LEXICON	
GEMINI 15	\$422	LEX II	\$106
Silver Reed Printers		TERMS - COD - Freight	
550P	\$648	COLLECT - Charge Card	
550S	\$675	Customers Add 4%	

[301] 695-5300
**COMPUTER
WHOLESALEERS
OF
FREDERICK**
A DIVISION OF TESCO INC.
7309C GROVE ROAD FREDERICK, MD. 21701

Help in Apple III Pascal

This easy-to-implement Help system offers online instructions and explanations anywhere in a program

by Al Evans

The ideal computer program features online instructions and explanations that save time and reduce the probability of making errors. But adding complete documentation or a Help system to a computer such as the Apple III must not substantially increase the complexity and bulk of the software it serves. And such a system should be sufficiently fast and flexible to use anywhere in application software.

An ideal Help system is not easy to realize with most available low-cost hardware/software combinations. The one described here, however, is readily implemented because it takes advantage of the modular structure of UCSD Pascal and the Apple III's advanced console-control capabilities. It can be used anywhere in a program to provide needed information. Listing 1 shows a program that demonstrates this Help system.

System Definition

Before implementing a complete online Help system, it's important to

consider the three basic areas within a program in which you might require additional information:

- *Help from the menu level.* Individual Help screens are attached to each menu item. Primarily instructional, they provide information about menu selection and describe its use or offer examples of the system's action when the item is selected.

"Infinite" Interruptibility Is required when you want to design a nearly ideal Help system.

- *Help during keyboard input.* During any request for input from the keyboard, detailed reminders describe what information you need to enter.
- *Help during a continuous process.* Help screens can be connected, for example, to procedures that display output to explain the data shown

and/or its format.

Unfortunately, these situations cover a seemingly infinite variety of machine states and cannot be reduced to a small number of cases that could be handled individually. What is required, then, is "infinite" interruptibility. This capability is provided by a set of techniques that enable you to easily interrupt any process at any time but that don't require special programming for individual cases and don't affect the process being interrupted.

One technique, keypress sensing, is easily implemented on most computers. Another incorporates a set of procedures to save and restore the exact state of the console screen, including all displayed data and the cursor position. On many small systems, implementing these procedures would require assembly-language programming; the Apple III, however, supports them through calls to the .CONSOLE driver.

In addition to software-interrupt techniques, you'll need a method of

Listing 1: A demonstration program of a Help system in Apple III Pascal.

```
PROGRAM HELP_DEMO;
(By Al Evans, 1982. Public domain -- use freely, but please give me credit)

CONST

(Help table of contents; give each help screen a name and enter it here.)
MENU1 = 1;
MENU2 = 2;
EX1 = 3;
EX2 = 4;

TYPE Byte = 0..255;
Buffer_2K = Packed Array[0..2048] of Byte;
Request_Code = Packed Record
    CHANNEL: 0..1;
    STAT_OR_CTRL: 0..1;
    REQUEST_NUM: 0..255;
    RESERVED: 0..63;
END;
XY_Coordinates = (X, Y);
Menu_Mode = (NORMAL_MODE, HELP_MODE);

VAR LEFT_ARROW, ESCAPE, HELP_KEY, BEEP: Char;
KEY_BUF_STATUS, SCREEN_SAVE, SCREEN_RESTORE: Request_Code;
SCREEN_POSITION: Request_Code;
SCREEN_BUFFER: Buffer_2K;
CURS_POS: Packed Array[XY_Coordinates] of Byte;
INPUT_SET: Set of Char;

(----- APPLE /// CONSOLE CONTROL -----)

Procedure Clear_Screen;
BEGIN
    Write(Chr(28))
END;

Procedure Inverse;
BEGIN
    Write(Chr(18))
END;

Procedure Normal;
BEGIN
    Write(Chr(17))
END;

(Though the demonstration program does not use viewports, the next two
procedures are required to provide HELP for programs that do. )

Procedure Reset_Viewport;
BEGIN
    Write(Chr(1))
END;

Procedure Restore_Viewport;
BEGIN
    Write(Chr(4))
END;

Procedure Back_Space;
BEGIN
    Write(Chr(8))
END;

Procedure Save_Screen;
CONST CONSOLE = 1;
BEGIN
    Unit_Status(CONSOLE, SCREEN_BUFFER, SCREEN_SAVE);
    Unit_Status(CONSOLE, CURS_POS, SCREEN_POSITION)
END;

Procedure Restore_Screen;
CONST CONSOLE = 1;
BEGIN
    Unit_Status(CONSOLE, SCREEN_BUFFER, SCREEN_RESTORE);
    GotoXY(CURS_POS[X], CURS_POS[Y])
END;

Function Keypressed: Boolean;
CONST CONSOLE = 1;
VAR CHARS_AVAIL: 0..255;
BEGIN
    CHARS_AVAIL := 0;
    Unit_Status(CONSOLE, CHARS_AVAIL, KEY_BUF_STATUS);
    Keypressed := CHARS_AVAIL > 0
END;

(-----)

Procedure Help(WHERE: Integer);
CONST
    (Enter the prefix for your HELP frames here)
    PREFIX = '/DEMO/FRAME';
    START_BLOCK = 0; (Change to 2 for Pascal text files)
    CONSOLE = 1;
```

Listing 1 continued on page 479

composing formatted Help screens and storing them as disk files. Any text editor that produces Pascal-compatible files will accomplish this step. We use Applewriter III (a word-processing program) or the Apple III Pascal editor set to ASCII (American National Standard Code for Information Interchange) mode to eliminate blocks of format data at the front of each UCSD Pascal text file because we don't need them for our purposes.

Finally, you'll need a way to get a screenful of formatted data quickly from a disk to the display. Providing this feature are the low-level Pascal procedures BLOCKREAD and UNITWRITE, which can be used to read and write large chunks of data regardless of type. In this case, they permit the system to find a Help frame on disk, read it, and display it on the screen in less than 3 seconds (or in much less time if a hard disk is used).

The System Design

To simplify use of the disk files containing the Help screens, the files are named systematically; the first is FRAME1, the second is FRAME2, and so on.

In the program's global-declarations section, a table of contents matches each program area for which Help is provided with its corresponding frame number. For example, a program in which the first two Help frames concern the first two items on the menu begins with the declaration

```
CONST MENU1 = 1;
      MENU2 = 2; . . .etc.
```

The Help procedure itself is declared as

```
Procedure Help(WHERE: Integer);
```

Calls to this procedure in the form of "Help(MENU1)" are thus permitted.

In order for you to be able to use the Help facility, the program must have three additional features. First, it needs a dual-mode menu that can act as a normal menu for program control or as a menu for instructional Help screens. We use the global

TYPE declaration

```
TYPE Menu_Mode = (NORMAL_
MODE, HELP_MODE);
```

to permit declaration of the menu itself, as

```
Procedure Menu(MODE:
Menu_Mode);
```

and employ the parameter MODE within the menu itself to control its action. The main program calls the menu as Menu(NORMAL_MODE). If the Help key is pressed from within the menu, it makes a recursive call to itself as Menu(HELP_MODE).

The program also needs a string-reading procedure that emulates Readln but can be interrupted at any time to use the Help system during input. Because it must read one character at a time, it will also be used to filter nonprinting characters out of the input. This procedure is declared as

```
Procedure Get_String(VAR
INPUT_LINE: String;
CALLING_PROC: Integer);
```

INPUT_LINE is the string to be built by the procedure; CALLING_PROC is one of the above global constants representing the Help screen that applies to the calling procedure.

Finally, for Help during a continuous process, we insert the line

```
If Keypressed Then Handle_Key;
```

wherever the process is to be interrupted. To complete the procedure, we use such instructions as

```
Procedure Handle_Key;
VAR KEY: Char;
BEGIN
  Read(KEYBOARD,KEY);
  If KEY = HELP_KEY Then
    Help(WHEREVER);
  { . . . etc. for any special keys to be
  handled }
END;
```

Implementing the Help System

Having covered our three general cases, we implemented the system in

Listing 1 continued:

```
VAR FRAME: Buffer_2K;
    BLOCK_COUNT: Integer;
    HELP_FILE: File;
    FILE_NAME: String;
    KEY: Char;
    CH_TO_STR: String[1];

BEGIN
  Reset_Viewport; (See note under Apple /// Console Control above)
  Save_Screen; Clear_Screen;
  Str(WHERE, FILE_NAME);
  FILE_NAME:= Concat(PREFIX, FILE_NAME);
  (%IOCHECK-)
  Reset(HELP_FILE, FILE_NAME);
  (%IOCHECK+)
  If IORESULT <> 0
  Then REPEAT
    Writeln(Chr(7),'Please put program disk online and press <RETURN>');
    Writeln('Or press <ESCAPE> to exit: ');
    Read(KEY);
    If KEY = ESCAPE
    Then BEGIN
      Restore_Screen;
      Restore_Viewport;
      Exit(Help)
    END;
    Clear_Screen;
    (%IOCHECK-)
    Reset(HELP_FILE, FILE_NAME);
    (%IOCHECK+)
    UNTIL IORESULT = 0;
  BLOCK_COUNT:= Block_Read(HELP_FILE, FRAME, 4, START_BLOCK);
  Unit_write(CONSOLE, FRAME, (BLOCK_COUNT * 512), 0, 0);
  GotoXY(0,23); Write('Press any key to proceed');
  Read(KEY);
  Close(HELP_FILE);
  Restore_Screen;
  Restore_Viewport (See above note concerning Reset_Viewport)
END;

Procedure Init_Variables;
BEGIN
  LEFT_ARROW:= Chr(8); BEEP:= Chr(7);
  ESCAPE:= Chr(27); HELP_KEY:= Chr(191); (Open-Apple-question-mark)
  INPUT_SET:= [Chr(32)..Chr(126)];
  With KEY_BUF_STATUS Do
    BEGIN
      CHANNEL:= 0;
      STAT_OR_CTRL:= 0;
      REQUEST_NUM:= 5;
      RESERVED:= 0
    END;
  With SCREEN_SAVE Do
    BEGIN
      CHANNEL:= 0;
      STAT_OR_CTRL:= 0;
      REQUEST_NUM:= 18;
      RESERVED:= 0
    END;
  With SCREEN_RESTORE Do
    BEGIN
      CHANNEL:= 0;
      STAT_OR_CTRL:= 1;
      REQUEST_NUM:= 18;
      RESERVED:= 0
    END;
  With SCREEN_POSITION Do
    BEGIN
      CHANNEL:= 0;
      STAT_OR_CTRL:= 0;
      REQUEST_NUM:= 16;
      RESERVED:= 0
    END
  END;

(Use this procedure for interruptible string input.
For demonstration purposes, enter it in the exact format shown so that
it will fit into 23 lines.)

(EX2 BEGIN)
Procedure Get_String(VAR INPUT_LINE: String; CALLING_PROC: Integer);
VAR KEY: Char; CH_TO_STRING: String[1];
BEGIN
  INPUT_LINE:= ''; CH_TO_STRING:= 'X';
  Read(KEYBOARD, KEY);
  While NOT EOLN(KEYBOARD) Do
    BEGIN
      If KEY = HELP_KEY Then Help(CALLING_PROC)
      Else If (KEY = LEFT_ARROW) AND (Length(INPUT_LINE) > 0)
      Then BEGIN
        Back_Space; Write(' '); Back_Space;
        INPUT_LINE:= Copy(INPUT_LINE, 1, Length(INPUT_LINE) - 1)
      END
      Else If KEY IN INPUT_SET
      Then BEGIN
        Write(KEY); CH_TO_STRING[1]:= KEY;
        INPUT_LINE:= Concat(INPUT_LINE, CH_TO_STRING)
      END
    END
  END;
```

Listing 1 continued on page 480

the Apple III. There it furnishes online Help from anywhere in the program in the form of a formatted screen display.

To use the system, the basic console-control procedures `Save__Screen` and `Restore__Screen` as well as the function `Keypress` are required. `Save__Screen` stores the console display's contents in a globally declared 2K-byte buffer and puts the cursor coordinates into a 2-byte packed array. `Restore__Screen` reverses this process. `Keypress` merely returns TRUE if a character is available to the Pascal system and FALSE if none is available (i.e., no key has been pressed).

On the Apple III, these operations are most easily performed using `D__STATUS` and `D__CONTROL` calls to the operating system via the Pascal `UNITSTATUS` procedure. (Refer to Listing 1 and the *Apple III Standard Device Driver's Manual*, pages 169 to 171, for more details.) The Pascal `UNITSTATUS` procedure is called as

```
UNITSTATUS(UNITNUMBER,
           STATUSLIST, REQUESTCODE);
```

`UNITNUMBER` is an expression with an integer value that is the Pascal unit number of an I/O (input/output) device (1 in the case of the `.CONSOLE` driver, for instance). `STATUSLIST` refers to a variable that contains or will contain the data to be passed to or from the device specified by `UNITNUMBER` (`SCREEN__BUFFER`, for example, in the case of `Save__Screen` and `Restore__Screen`). `REQUESTCODE` is a 16-bit packed record that indicates whether the device's input or output channel will be affected by the call, whether it is a status (`D__STATUS`) or control (`D__CONTROL`) call, and the type of status or control call being made. This record is declared as

```
Type Request__Code = Packed
  Record
    CHANNEL: 0..1;
    STAT_OR_CTRL: 0..1;
    REQUEST_NUM: 0..255;
    RESERVED: 0..63
  END;
```

Listing 1 continued:

```

      Else Write(BEEP);
      Read(KEYBOARD, KEY)
    END;
    WriteLn
  END; (Get_String)
  (EX2 END)

(MENU1 PART 1 BEGIN)
Procedure Example1;

(An example of HELP during a continuous process, in this case a continuous
screen display. HELP would normally be used in this instance to provide
information on the format and/or meaning of the display. )

VAR FOREVER: Boolean;
(MENU1 PART 1 END)

(EX1 BEGIN)
  Procedure Handle_Key;
  VAR KEY: Char;
  BEGIN
    Read(KEYBOARD, KEY);
    If KEY = HELP_KEY Then Help(EX1);
    If KEY = ESCAPE Then Exit(Example1)
  END;

  Procedure Slowprint(LINE: String);

  (This procedure is given as the extreme example of interruption during
  display -- the process can be interrupted after each character is dis-
  played. Of course the display would be much faster if written a line
  at a time and if "Keypress" was checked only at the end of each line.)

  VAR CHAR_COUNT: Integer;
  BEGIN
    For CHAR_COUNT:= 1 to Length(LINE) Do
      BEGIN
        Write(LINE[CHAR_COUNT]);
        If Keypress Then Handle_Key
      END
    END;
  (EX1 END)

(MENU1 PART 2 BEGIN)
BEGIN (Example1)
  FOREVER:= FALSE;
  Clear_Screen;
  REPEAT
    Slowprint('This is an example of how HELP can be provided during an ');
    Slowprint('ongoing process. This text will simply be displayed repeatedly ');
    Slowprint('until you push <ESCAPE>. While it is being displayed, you can ');
    Slowprint('press ""<open-apple>?"', and whatever help screen you have
    attached will ');
    Slowprint('be displayed instead. When you return to this display after ');
    Slowprint('reading the HELP display, the process will begin again exactly ');
    Slowprint('where it left off. ');
  UNTIL FOREVER
END;
(MENU1 PART 2 END)

(MENU2 BEGIN)
Procedure Example2;
VAR LINE: String;

BEGIN
  Clear_Screen;
  WriteLn('This procedure demonstrates HELP during the input of a string');
  WriteLn('from the keyboard. The HELP_KEY can be pressed any time during');
  WriteLn('entry. Enter ""Stop"" when finished');
  REPEAT
    Write('Enter string: ');
    Get_String(LINE, EX2); (Example of a call to Get_String)
    WriteLn('You entered: ',LINE)
  UNTIL LINE = 'Stop'
END;
(MENU2 END)

Procedure Menu(MODE: Menu_Mode);
VAR CHOICE: Char;
BEGIN
  REPEAT
    Clear_Screen;
    If MODE = NORMAL_MODE
    Then BEGIN
      GotoXY(65,23);
      Write('""<open-apple>?"' for HELP')
    END;
    GotoXY(0,4);
    WriteLn(' ':5,'Demonstrations available:');
    WriteLn;
    (Enter your menu here)
    WriteLn(' ':5,'1) HELP during continuous output process');
    WriteLn(' ':5,'2) HELP during input from keyboard');
    WriteLn;
    If MODE = HELP_MODE
    Then BEGIN
      Write(' ':5);
      Inverse;

```

Listing 1 continued on page 481

Listing 1 continued:

```
Write('Now in HELP mode. Choose topic for instructions.');
```

```
Normal;
```

```
WriteLn
```

```
END;
```

```
WriteLn(' :S, <ESCAPE> to quit');
```

```
Write(' :S, Option: '); Read(CHOICE);
```

```
If MODE = NORMAL_MODE
```

```
Then Case CHOICE of
```

```
  (Enter your program's responses to menu choices here)
```

```
  '1': Example1;
```

```
  '2': Example2;
```

```
END
```

```
Else Case CHOICE of
```

```
  (Enter your menu's HELP frames here)
```

```
  '1': Help(MENU1);
```

```
  '2': Help(MENU2)
```

```
END;
```

```
If (MODE = NORMAL_MODE) AND (CHOICE = HELP_KEY)
```

```
Then Menu(HELP_MODE)
```

```
UNTIL CHOICE = ESCAPE
```

```
END;
```



```
BEGIN (*MAIN PROGRAM*)
```

```
  Init_Variables;
```

```
  Menu(NORMAL_MODE);
```

```
  Clear_Screen
```

```
END.
```

The specific request codes used as commands to the .CONSOLE device driver are declared as global variables (KEY_BUF_STATUS, SCREEN_SAVE, SCREEN_RESTORE, SCREEN_POSITION) of the type RequestCode and initialized in an Init_Variables procedure. The following instructions provide an example.

```
With SCREEN_SAVE Do
```

```
  BEGIN
```

```
    CHANNEL:= 0;
```

```
    STAT_OR_CTRL:= 0;
```

```
    REQUEST_NUM:= 18;
```

```
    RESERVED:= 0
```

```
  END;
```

Using the Help Procedure

The operation of the Help procedure itself is simple. It saves and clears the screen (and resets the viewport to include the full screen, although this action is not required by the demonstration program provided), then looks on the volume specified by PREFIX for a FRAME file with the frame number passed to it as the parameter WHERE. If it finds the file, it reads as many as four blocks (2048 characters, slightly more than one screenful) using Block_Read. Using Unit_Write, it writes the data all at once to the console. It then waits for a keypress, closes the file, and restores the screen and viewport to the state they were in when Help was called.

Before compilation, two constants

in this procedure are set for each specific application. PREFIX is set to the complete volume and file name of the Help files through FRAME—for example, /DEMO/FRAME (or, in UCSD Pascal notation, DEMO:FRAME). The procedure concatenates the parameter WHERE to PREFIX, resulting in /DEMO/FRAME1, /DEMO/FRAME2, and so on. START_BLOCK is set to 0 for an ASCII file or to 2 for a Pascal text file to skip the two-block header.

You can install the Help system in any program by filling in the blanks.

Much of the procedure is dedicated to ensuring that the system doesn't crash if the disk containing the Help frames goes off line and to providing an Exit option if these files are unavailable. This portion (from If IORESULT <> 0 . . . to . . . UNTIL IORESULT = 0, as well as the preceding {\$IOCHECK -} and {\$IOCHECK +}) can be eliminated if these files will always be on line (in a hard-disk system, for example).

The Demonstration Program

Enter the demonstration program, compile it, and execute it. Be sure to set the constant PREFIX in the Help procedure to the volume name of the disk you will use for the Help files

plus /FRAME (e.g., /DEMO/FRAME). And note that the HELP_KEY used is Open-apple-question-mark [Chr (191)]. The Open-apple key is a kind of "supershift" key that adds 128 to the decimal equivalent of the ASCII code for any character typed with it. (Because the open apple is itself a nonprinting character on our printer, we changed all literal open apples in the program to <open-apple>. When you enter the program, these references should be replaced for display purposes with actual open apples, which are entered by typing control-shift-backslash.)

At this point, any call for Help should receive the answer "Please put program disk on line and press <RETURN> or press <ESCAPE> to exit." Otherwise, the program should operate in the following manner.

From the NORMAL_MODE menu, the first menu choice should result in a continuing text display that is interruptible only by pressing <ESCAPE> or "open-apple-question-mark." The second menu choice should demonstrate string entry (with echo for confirmation), which can be interrupted by entering an "open-apple-question-mark" with the same results as before and exited by entering the string "Stop." Entering "open-apple-question-mark" from the NORMAL_MODE menu brings up the HELP_MODE menu. Either choice from the HELP_MODE menu should produce "Please put program disk on line. . ." and <ESCAPE> should return you to the NORMAL_MODE menu.

Now let's make some Help screens. For demonstration purposes, we'll use appropriate portions of the program itself. The following instructions are specifically applicable to the Apple III Pascal editor. Regardless of the editor, however, the objective is the same—to delete all except certain portions and to save these portions as ASCII text files. The operations required for any editor are very similar.

Read the program text file into the Pascal editor again, then set the editor to ASCII mode [S(et E(nviron-

ment A(Sciifile T(rue <CTRL C>). Note the comments {MENU1 PART1 BEGIN}, {MENU1 PART1 END}, {MENU1 PART2 BEGIN}, and {MENU1 PART2 END}. DELETE or ZAP everything in the program *except* these two sections, taking care not to leave any extra carriage returns at the beginning or end of the file. The file should begin at the first character and end immediately after the last character of the text to be used as the Help frame. Q(uit and W(rite the file to your disk as <name of your disk >/FRAME1. Do not use the S(ave option here, or you will lose the program text file.

Choose the C(hange files option and reload the complete program text. Repeat the entire process for MENU2, EX1, and EX2 (naming the Help files FRAME2, FRAME3, and FRAME4). When you execute the program and request Help, the display should show the applicable part of the source code.

Installing the Help System

You can install the Help system in

any program by appropriately filling in the blanks. First, copy the type declarations, the global variables, the console control procedures, and the Init_Variables procedure directly into your program. Next, copy the Help procedure, setting the constant PREFIX to that for your own Help files and the constant START_BLOCK to 0 (for ASCII or data files) or 2 (for Pascal text files).

Then compose a table of contents of the Help screens to be provided and enter it in the program's global constants section. After that, insert calls to Help in the body of your program wherever Help is to be provided, and copy the procedure Get_String—to use wherever Help will be available during string input. Use the technique demonstrated by the procedure Example1 to provide Help anywhere else in your program. The next step is to copy the menu procedure, changing the entries, program actions, and HELP calls to fit your program.

Finally, use the Pascal editor or any other text editor that can write a for-

matted text file on disk to compose your Help frames, limiting each frame to 23 or fewer lines. Name the disk files FRAME1, FRAME2, and so on to match the values assigned to the help screens in the global constants section. If you are using Pascal text files, end all of these file names with periods to keep the editor from appending ".TEXT" to them.

When you are finished, ask someone who's unfamiliar with your system to use it to test its usefulness and completeness. Note that you can edit individual HELP frames as many times as necessary; recompile your program only if you are adding or eliminating frames or changing the locations of the HELP calls, the path name of the HELP files, or Pascal Text files to ASCII files.

When everything is perfect, you can relax in the knowledge that help is always available.■

Al Evans (1206 Karen Ave., Austin, TX 78757) is the owner of PowerTools, a small research company primarily engaged in developing new approaches to Software design and computer use.

Monitor Computing Incorporated

(213) 885-5715

Mail orders:

Monitor Computing Inc.
8608 Wilbur Ave.
Northridge Ca. 91324

Availability on some items limited. Prices subject to change.

All items in factory sealed cartons, covered by factory warranties.

We accept cash, cashiers check, m/c and visa. Credit card use subject to a 3% surcharge.

Shipping added to all orders. California residents add sales tax.

APPLE PRODUCTS

16K Memory Card	\$55.00
Microtek Magnum80	\$179.00
Videx 80 Col.	\$249.00
Microsoft Z-80	\$249.00
Microsoft Premium System	\$469.00
Add-On Drive	\$240.00
Kraft Joystick	\$48.00
Grappler+	\$119.00
System Saver	\$74.00

PRINTERS

Okidata 82	\$399.00
Okidata 83	\$639.00
Okidata 84p	\$949.00
Okidata 84s	\$999.00
Okidata 92	\$490.00
Okidata 93	\$810.00
C.Itoh 8510ap	\$379.00
C.Itoh 8510bd	\$499.00
C.Itoh 1550p	\$675.00
C.Itoh 1550s	\$735.00
C.Itoh F10-40	\$1199.00
C.Itoh F10-55	\$1489.00
Nec 8023	\$399.00
Nec 7710	\$1965.00
Nec 7730	\$1965.00
Toshiba P1350	\$1495.00

MODEMS

Hayes Smartmodem 300	\$211.00
Hayes Smartmodem1200	\$499.00

SPECIALS

Wabash 8" Diskettes ... **\$19.00**

Head Cleaning Kit

Smith-Corona TP1 **\$499.00**

Comrex Cr-1S

Diablo 630

Atari joystick

Axlon 320K Ramdisk .. **\$795.00**

EPD Surge Protectors

Lemon

Peach

Lime

Orange

MORE MODEMS

Hayes Micromodem 2	\$279.00
w/term. program	\$315.00

IBM PRODUCTS

AST Combo Board	\$345.00
Quadram 4 Function Board ...	\$270.00
Tandon 100-2 Disk Drive	\$268.00
Datamac Hard Disk Drives	
6 Megabyte	\$1195.00
12 Megabyte	\$1595.00
18 Megabyte	\$1995.00

MONITORS

Taxan Green	\$139.00
Taxan Amber	\$149.00
Taxan RGB Med-Res	\$329.00
Taxan RGB Hi-Res	\$499.00
Apple Interface	CALL
Amdek Color 1	\$299.00
Amdek Color 2	\$399.00
Amdek 300G	\$139.00
Amdek 300A	\$159.00
Nec 1201 Green	\$169.00
Nec 1205 Amber	\$189.00
Nec Composite Color	\$299.00

TERMINALS

Televideo 925	\$695.00
Televideo 950	\$895.00
Axlon Datalink	\$289.00

Books Received

Campus Computing Strategies, John W. McCredie, ed. Bedford, MA: Digital Equipment Corp., 1983; 326 pages, 15.5 by 23.5 cm, hardcover, ISBN 0-932376-20-7, \$21.

Chip Mitchell: The Case of the Stolen Computer Brains, Fred D'Ignazio. New York: E.P. Dutton, 1982; 128 pages, 14.3 by 21.5 cm, hardcover, ISBN 0-525-66790-3, \$8.95.

Computer-Aided Design, Raphael Kaplinsky. New York: Macmillan Publishing Co., 1982; 144 pages, 15.5 by 23.5 cm, hardcover, ISBN 0-02-949520-2, \$22.95.

Computer Anatomy for Beginners, Marlin Ouverson. Reston, VA: Reston Publishing Co., 1982; 159 pages, 15.5 by 23.5 cm, hardcover, ISBN 0-8359-0920-4, \$15.95.

Computers—How to Break Into the Field, L. Peter Carron Jr. Cockeysville, MD: Liberty Publishing Co. (50 Scott Adam Rd.), 1982; 162 pages, 14 by 21 cm, softcover, ISBN 0-89709-034-9, \$6.95.

Computer-System Requirements, Kenneth J. Thurber and Peter C. Patton. Lexington, MA: Lexington Books, 1983; 28 pages, 16.5 by 23.5 cm, hardcover, ISBN 0-669-02958-0, \$15.95.

Database & Data Communications Systems, Myles E. Walsh. Reston, VA: Reston Publishing Co., 1983; 287 pages, 18 by 24.3 cm, hardcover, ISBN 0-8359-1218-3, \$22.95.

Dynamic Testing and Seismic Qualification Practice, Clarence W. deSilva. Lexington, MA: Lexington Books, 1983; 416 pages, 16.5 by 23.5 cm, hardcover, ISBN 0-669-04393-1, \$47.95.

Electrically Alterable Non-Volatile Memory Handbook, Revision A. Hicksville, NY: General Instrument Corp. (600 West John St.), 1983; 17.8 by 23 cm, softcover, ISBN-none, free.

Fundamentals of Micro-Pro-

cessors, Henry O. Daley. New York: Holt, Rinehart and Winston, 1983; 277 pages, 16.5 by 24 cm, hardcover, ISBN 0-03-059934-2, \$27.95.

The Handbook of Problem Solving, Stephen J. Andriole. Princeton, NJ: Petrocelli Books, 1983; 208 pages, 15.8 by 24 cm, hardcover, ISBN 089433-186-8, \$25.

The IBM/PC Guide, James E. Kelley Jr. Wayne, PA: Banbury Books, 1983; 318 pages, 15 by 23.5 cm, spiral bound, ISBN 0-440-03946-0, \$29.95. Includes 5 1/4-inch floppy disk.

Introduction to Programming with ESP and Pascal, Allen B. Tucker Jr. New York: Holt, Rinehart and Winston, 1983; 362 pages, 17.8 by 23.5 cm, softcover, ISBN 0-03-059148-1, \$19.95.

Introductory Reading in Expert Systems, Donald Michie, ed. New York: Gordon and Breach, Science Publishers, 1982; 51 pages, 15.5 by 23.5 cm, hardcover, ISBN 0-677-16350-9, \$25.

Kids and Computers, The Parents' Microcomputer Handbook, Eugene Galanter. New York: Perigee Books, 1983; 192 pages, 17.8 by 23.5 cm, softcover, ISBN 0-399-50749-3, \$7.95.

Enduser Systems and Their Human Factors, A. Blaser and M. Zoepfritz, eds. Lecture Notes in Computer Science, #150. New York: Springer-Verlag, 1983; 142 pages, 16.5 by 24 cm, softcover, ISBN 3-540-12273-7, \$8.50.

Microprocessor and Microcomputer Data Digest, Walter H. Buchsbaum and Gina Weissenberg. Reston, VA: Reston Publishing Co., 1983; 352 pages, 18.5 by 24.3 cm, hardcover, ISBN 0-8359-4381-X, \$26.95.

Microprocessors for Management: CAD, CAM, and Robotics, Dimitris N. Chorafas. Princeton, NJ: Pet-

rocelli Books, 1982; 318 pages, 16 by 24 cm, hardcover, ISBN 0-89433-183-3, \$25.

Mouse: A Language for Microcomputers, Peter Grogono. Princeton, NJ: Petrocelli Books, 1983; 168 pages, 16 by 24 cm, hardcover, ISBN 0-89433-201-5, \$17.50.

1983 Components Handbook. Irvine, CA: Western Digital Corp., 1983; 752 pages, 17.5 by 22.8 cm, softcover, ISBN-none, \$6.

1983 Network Products Handbook, Irvine, CA: Western Digital Corp., 1983; 224 pages, 17.5 by 22.8 cm, softcover, ISBN-none, \$4.

Online Reference and Information Retrieval, Roger C. Palmer. Littleton, CO: Libraries Unlimited Inc. (POB 263), 1983; 149 pages, 21.5 by 27.8 cm, softcover, ISBN 0-87287-347-1, \$18.50.

Programming Concepts and Problem Solving: An Introduction to Computer Science Using Pascal, Peter Linz. Menlo Park, CA: The Benjamin/Cummings Publishing Co., (2727 Sand Hill Rd.), 1983; 416 pages, 19.5 by 24 cm, hardcover, ISBN 0-8053-5710-6, \$21.95.

Programming the IBM Personal Computer: BASIC, Neill Graham. New York: Holt, Rinehart and Winston, 1982; 304 pages, 17.5 by 23.5 cm, softcover, ISBN 0-03-061911-4, \$17.95.

Programming Languages: A Grand Tour, Ellis Horowitz. Rockville, MD: Computer Science Press, 1983; 680 pages, 21.8 by 28.5 cm, hardcover, ISBN 0-914894-67-6, \$39.95.

Software Engineering with Ada, Grady Booch. Menlo Park, CA: The Benjamin/Cummings Publishing Co. (2727 Sand Hill Rd.), 1983; 524 pages, 15.8 by 23.5 cm, softcover, ISBN 0-8053-0600-5, \$19.95.

Software Referral Catalog,

10th ed., Engineering Systems Group. Bedford, MA: Digital Equipment Corp., 1983; 266 pages, 21.5 by 27.5 cm, softcover, ISBN-none, \$10.

Software Toolkit for Microcomputers, Max Schindler, ed. Rochelle Park, NJ: Hayden Book Co., 1982; 368 pages, 21.5 by 17.5 cm, softcover, ISBN 0-8104-6256-7, \$14.95.

Structured COBOL, A Modern Approach, Henry Mullish. New York: Harper & Row, 1983; 384 pages, 21 by 27.8 cm, softcover, ISBN 0-06-044652-8, \$20.50.

The Timex-Sinclair 1983 Directory, Eben Brown. Alexandria, MN: E. Arthur Brown Co., 1983; 94 pages, 14 by 21.5 cm, softcover, ISBN-none, \$5.

Transducers, Sensors, and Detectors, Robert G. Seippel. Reston, VA: Reston Publishing Co., 1983; 320 pages 18 by 24.3 cm, hardcover, ISBN 0-8359-7797-8, \$24.95.

Will Someone Please Tell Me What an Apple Can Do, Glenn M. Polin, ed. Austin, TX: Sterling Swift Publishing, 1983; 145 pages, 15.3 by 21.8 cm, softcover, ISBN 0-88408-152-4, \$12.95.

Word Processing: A Guide for Small Business, Brian R. Smith and Daniel J. Austin. Brattleboro, VT: Stephen Greene Press, 1983; 224 pages, 15 by 22.8 cm, softcover, ISBN 0-86616-021-3, \$9.95.

Word Processing With Your Microcomputer, L. R. Schmeltz. Blue Ridge Summit, PA: Tab Books, 1982; 256 pages, 19.5 by 23.5 cm, softcover, ISBN 0-8306-1478-8, \$13.95.

Your IBM Personal Computer, David E. Cortesi. New York: Holt, Rinehart and Winston, 1982; 253 pages, 17.8 by 23.5 cm, softcover, ISBN 0-03-061979-3, \$17.95. ■

Conducted by Steve Clarcla

Under-\$50 Modem Configured for CCITT

Dear Steve,

I built your "modem for under \$50" and modified it for use with CCITT frequencies, which are standard in South Africa. (See "A Build-It-Yourself Modem for Under \$50," August 1980 BYTE, page 22.) I also expanded it to allow switching between answer and originate modes. What follows shows that the additional modifications cost less than \$5.

The main feature of my design lies in the use of CMOS (complementary metal-oxide semiconductor) bilateral analog switches (CD4066, MC14066, etc.). These allow all switching to be done on the printed-circuit board, controlled by a SPDT (single-pole, double-throw) switch on the front panel. As the 4066 is variously described as having a maximum supply voltage of 15 or 18 V (volts), I designed my circuit to work off +5 and -5-V supplies. I found no difficulty in operating the XR2211 at 5 V.

Table 1 shows the comparison between the Bell

system and the CCITT frequencies. For the CCITT system, the higher frequency is the space code, which is the reverse of the Bell system. To get around this, I simply moved gate (c) of the 4011 in your design to invert the output of IC4(b) before entering IC7. Q3 now feeds directly to Q2 via a 4.7k resistor.

Referring to your parameter-value equations for the bandpass filters in figure 3 (page 32), it is seen that for a fixed capacitance C:

- (1) bandwidth is defined by R3
- (2) gain is defined by R1
- (3) center frequency is determined by R2.

I left the bandwidth the same. After some juggling I came up with R1 = 4.7k (which increases the gain somewhat) and the following values for R2:

$$\begin{aligned} f_o = 1080 & \quad R2 = 2943 \\ f_o = 1750 & \quad R2 = 808 \end{aligned}$$

The on-resistance of a 4066 is around 90 to 110 ohms. After some experimentation, we get to the practical circuit in

	Originate		Answer	
	Bell	CCITT	Bell	CCITT
Mark	1270	980	2225	1650
Space	1070	1180	2025	1850

Table 1: Comparison of Bell standard and CCITT frequencies.

figure 1 (repeated twice).

As mentioned above, the 4066 is supplied from +5 and -5 V to encompass equal swings above and below ground potential. The actual swing is very small. Up to this point, only half a 4066 package is required to switch the bandpass filter between originate and answer modes.

I kept the demodulator's timing capacitor C_o constant at 0.022μF (microfarad). This gave me the following values for R_o:

$$\begin{aligned} f_o = 1080 & \quad R_o = 42087 \\ f_o = 1750 & \quad R_o = 25974 \end{aligned}$$

This is realized in practice as shown in figure 2. I altered R1 to 220k and C_D to 0.068μF. Your original component value for C_r of 0.005μF does not match up with EXAR's design sheets, but I agree that it works better.

In the modulator section, the center frequency for the NE567/XR567 triangular-wave oscillator is given approximately by $f = 1/RC$. If R is held constant, then for frequencies f₁ and f₂ capacitances C₁ and C₂ would be required as follows:

$$\frac{C_1}{C_2} = \frac{f_2}{f_1}$$

Your original design had:

$$\frac{C_1}{C_2} = \frac{25.7}{22} = 1.168$$

where:

$$\frac{f_2}{f_1} = \frac{1270}{1070} = 1.187$$

This is close enough, particularly considering the tolerances of the components. I retained these capacitor values for the

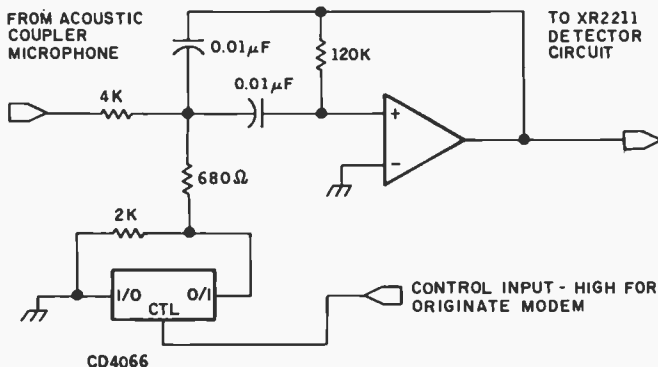

Figure 1: Solid-state switch alters microphone-driven filter to allow either answer or originate modes. The switch is a CMOS 4066 type.

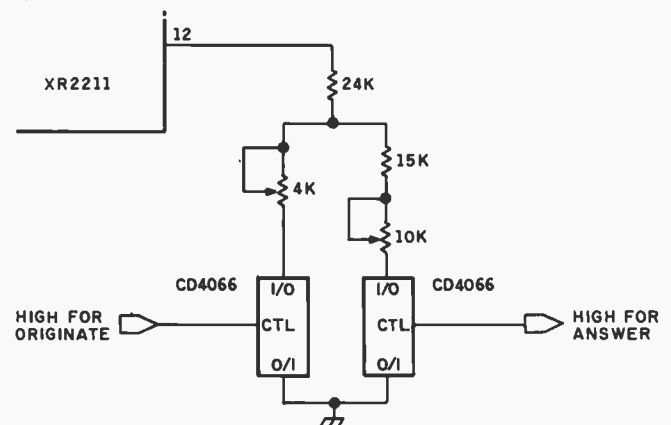

Figure 2: Demodulator-control circuit modified to allow switching between answer and originate modes.

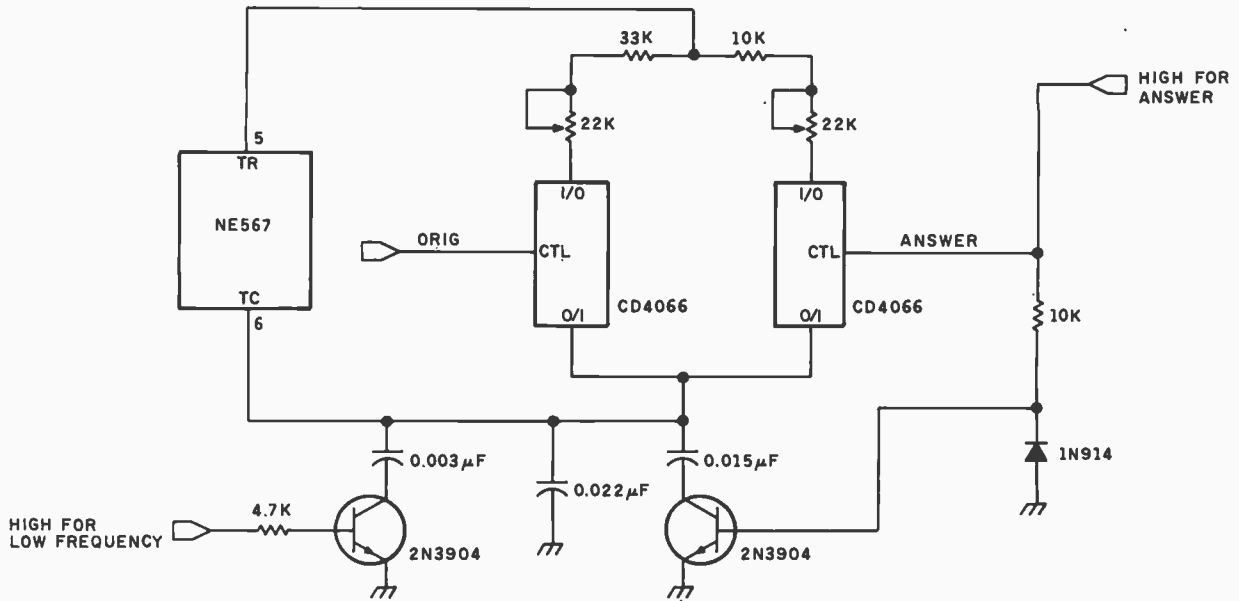

Figure 3: Answer or originate tones are modulated by simple control signals.

originate mode, where our frequencies give:

$$\frac{f_2}{f_1} = \frac{1850}{1650} = 1.12$$

This still appears satisfactory.

For the answer mode, I switched in an additional capacitor of 0.015µF in parallel and a different preset potentiometer. This gives us:

$$\frac{f_2}{f_1} = \frac{1180}{1190} = 1.204$$

and:

$$\frac{C_1}{C_2} = \frac{40.7}{37} = 37 = 1.100$$

This does not look very good, but works quite well in practice, helped a little by the fact that the original formula $f = 1/RC$ is not quite correct. I therefore have the circuit shown in figure 3.

I used one 4066 gate to invert the control switch signal, as some analog switches are

while others are off. The final 4066 gate was then used to hold the transmit carrier permanently on when in answer mode.

I have constructed 22 of these modems to date, without these major difficulties. Minor problems all revolve around the use of a 4011 in the linear mode: the gate handling Carrier Detect tends to oscillate for a time while changing state and affects the other gates in the package. Also, A-

type CMOS is definitely not suitable. I would like to extend the time delay on the Carrier Detect, but this is not practical for the same reason. The mid-frequency of the filters tends to shift with component tolerances, but all have worked so far. My complete circuit is diagrammed in figure 4, page 286-287.

The circuit can be improved still further, but this will increase the component count even more. For my

How good are you at maintaining good health?

Test yourself. Find out how much you know about first aid, accident prevention, home nursing skills and reducing your risk of heart disease. This is not a pass or fail test. Its purpose is to tell you how well you're doing in maintaining good health.

- | | |
|--|---|
| <p>1 What should you do to control bleeding from a wound?</p> <p>a Apply pressure directly over the wound.</p> <p>b Run cold water over the wound.</p> <p>c Apply a tourniquet.</p> | <p>3 The best place to check the pulse in an emergency is at the:</p> <p>a Upper arm.</p> <p>b Neck.</p> <p>c Wrist.</p> <p>d Thigh.</p> |
| <p>2 Overweight individuals are at greater risk for:</p> <p>a Diabetes.</p> <p>b Gall bladder disease.</p> <p>c High blood pressure.</p> <p>d All of the above.</p> | <p>4 What are the most common symptoms of high blood pressure?</p> <p>a Dizziness.</p> <p>b Headaches.</p> <p>c Heart palpitations.</p> <p>d No symptoms, usually.</p> |

ANSWERS: (1)a (2)d (3)b (4)d
 Score 25 points for each correct answer.
100 — Excellent: Your answers show you're aware of the importance of maintaining good health.
75 — Good: But there's room for improvement.
50 or below — You need help! Call Red Cross for a listing of the health and safety courses available at your local chapter. Countless lives have been saved through safety and health skills learned through Red Cross courses. Because of these skills, millions of Americans live safer, happier, healthier lives.

American Red Cross



A Public Service of This Magazine & The Advertising Council

We'll Help. Will You?

money, I propose using a digital modem chip, such as the Motorola MC14412 in the next version.

**Peter Hers, Vice-Chairman
Transvaal Amateur
Computer Club
Randburg, South Africa**

I have received a number of letters from experimenters who have modified that original modem circuit. The Circuit Cellar and Ask BYTE are good test beds for checking various designs, and I have modified it a few times myself. We are in

good company however, since thousands of this design and the newer version presented in the March 1983 BYTE have been sold. (See "Build the ECM-103, An Originate/Answer Modem," page 26.) . . . Steve

Extending the Bus

Dear Steve,

I've stuffed my S-100 computer, a North Star II, quite full, the power supply is heavily loaded, and the sys-

tem runs hotter than I like.

Is it feasible to build or buy another box with motherboard slots and power supply and extend the bus into it? Or would I have essentially insurmountable problems with unterminated or mismatched lines, noise, pulse distortion or delay, etc.? The distance between the motherboards would only be about 6 inches or so, and I've never encountered any ill-effects from using an extender board that big for troubleshooting.

Can you give me any suggestions?

**Burt H. Andrews
Potomac, MD**

It seems that no matter how large the motherboard is, there are never enough slots to handle all of the cards. Extending the S-100 bus is feasible if some precautions are taken. The most important one is to keep the extension cable or card as short as possible and ensure that the processor board is capable of driving the additional boards.

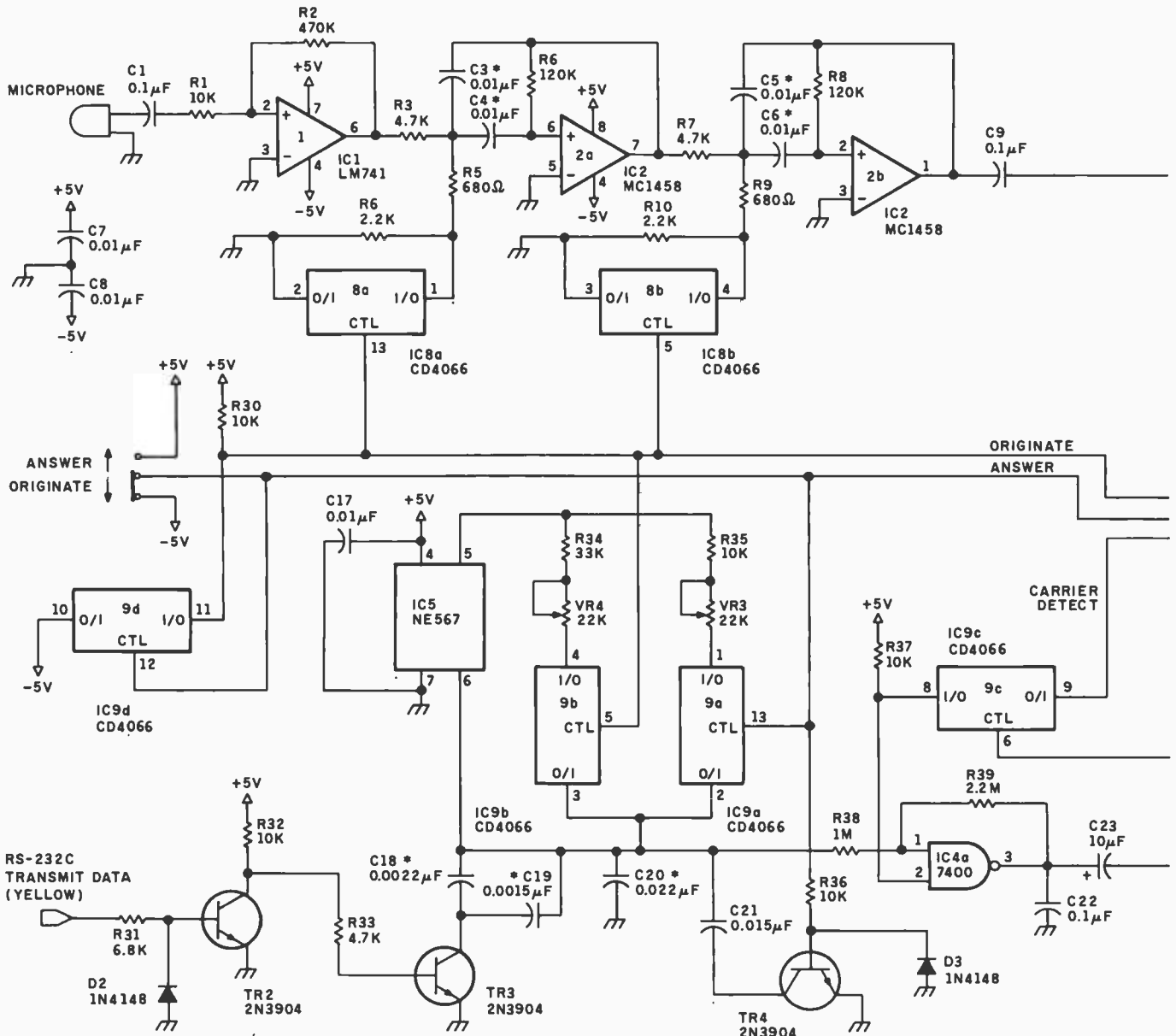

Figure 4: The complete modem circuit as modified for Answer and Originate CCITT.

If a separate power supply is used, tie it to the new expansion board only. Naturally, the two units should have a common ground.

To minimize noise on the bus, some form of termination, either active or passive, should be incorporated. Placing the processor board near the middle of the two units will effectively reduce the length of the bus. You might consider mounting the two motherboards back-to-back. This would allow the interbus board connection to be less than an inch. . . .Steve

Humidity Detection

Dear Steve,

I have a digital clock and thermometer module but I also want to be able to monitor humidity. What kind of sensing device can I use for this?

Dennis C. White
Whiteman AFB, MO

Of the several means of measuring humidity (wet and dry bulb thermometers, horse-hair hygrometers, etc.), the simplest method is to use a

humidity-sensitive resistance element. One such unit is the Model PCRC-11 manufactured by Phys-Chemical Research Corp., 36 West 20th St., New York, NY 10011, (212) 924-2070. It consists of a chemically treated styrene copolymer. It responds very rapidly because its humidity-sensitive portion is at the surface.

A circuit using this element was described in the June 5, 1980 issue of EDN magazine. (See "An Elegant 6-IC Circuit Gauges Relative Humidity" by Jim Williams.) The output is a

DC voltage from 0 to 10 V for a humidity range of 0 to 100%, and the circuit features an overall 2% accuracy. The 0 to 10-V output can be fed to a voltage-to-frequency converter and counted by a simple computer program to read relative humidity. According to the article, the unit cost about \$30. . . . Steve

Bar-Code Reader for Popular Computers

Dear Steve,

Do you know where I can

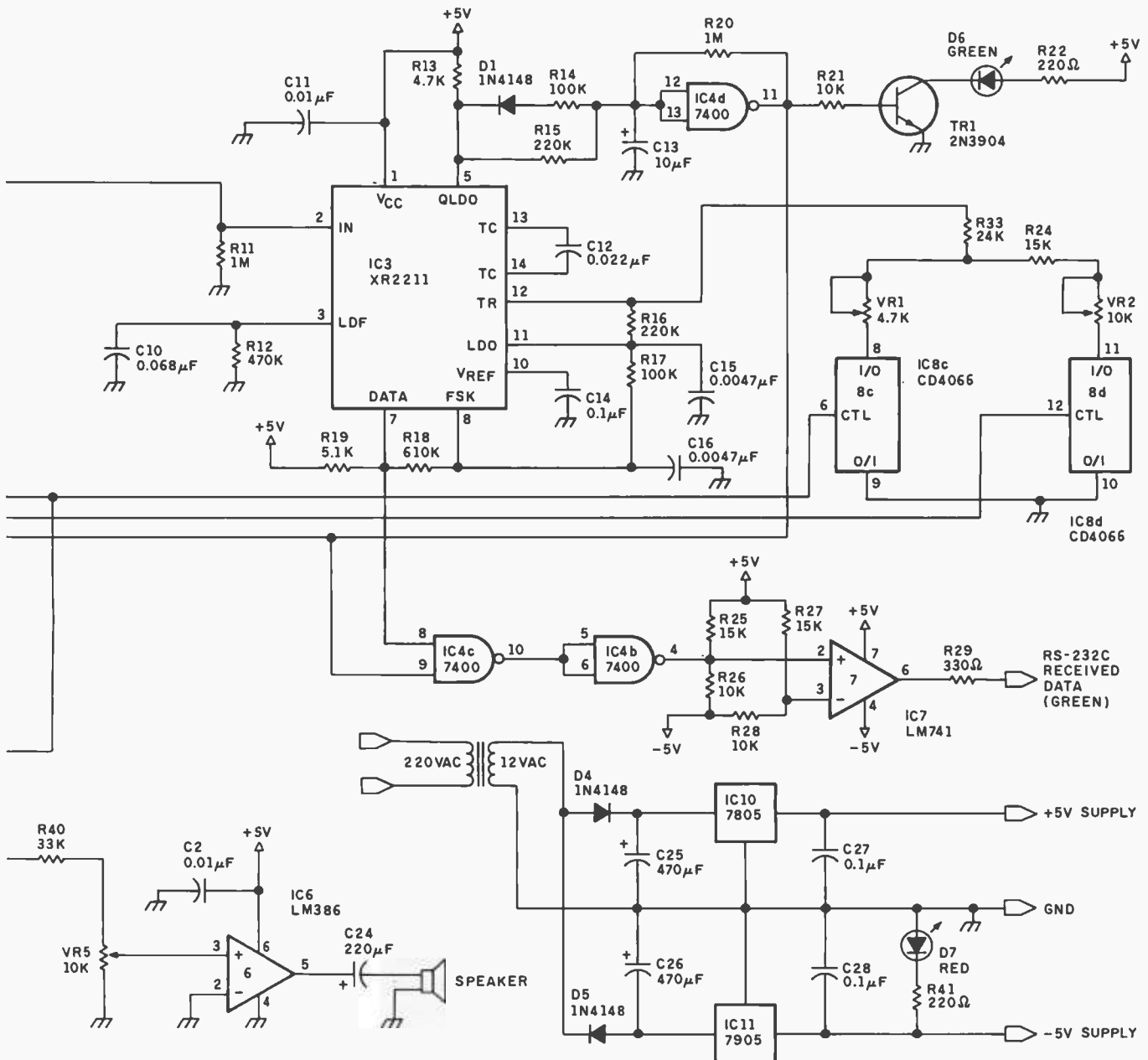

buy an inexpensive (less than \$225) bar-code reader that I can use with my Osborne 1? **Rich Weiss**
Fullerton, CA

I am not aware of a bar-code reader made exclusively for the Osborne 1, but Hewlett-Packard makes a Digital Wand, called the Model HEDS-3000. It sells for around \$100 and can be interfaced to any computer.

An article describing the construction and interfacing of such a unit appeared in the November 1981 BYTE ("Build a Bar-Code Scanner Inexpensively" by Bradley W. Bennett, page 62). In addition, a BYTE Book, Bar Code Loader by Ken Budnick, contains general bar-code loader algorithms with detailed assemblies for the 6800, 6502, and 8080 processors. Best of all, the book is only \$2. . . . Steve

Electronic Office Messenger

Dear Steve,

I have a pet project that is an outgrowth of certain communications inefficiencies in my commercial real estate brokerage office. I find it difficult and annoying to put one telephone call on hold while I find out who is calling on another line. This is true for each of the ten associates here. Audible signaling in newer Bell equipment isn't helping.

I would like to build a system, not involving video-display terminals, to display information at our desks regarding who is calling or in the lobby to visit us, as keyed in by our secretary. To minimize the inconvenience of wiring up our suite of offices, I would like to send the information over the AC line, in a manner similar to the BSR light-switching system available for about \$100.

If this goes together and is well received in my company, I would like to sell systems to other companies as a subsidiary activity, and could capitalize such a subsidiary with \$50,000 or so. Therefore I have sent in a patent preliminary application to see if anything in this system idea is novel enough to protect.

My hobbyist activities have been on the level of building Heathkits. I would appreciate any direction you might be able to provide in this matter. **J. Ross Millie**
Dallas, TX

Your pet project of a communications device between a secretary and multiple associates is both novel and practical. The following comments are offered for your consideration: The use of an alphanumeric keypad by the secretary is perhaps the simplest and most convenient means for data transmission. A switching device could be wired into the keyboard to send the data to the proper associate.

The idea of sending data through the AC power lines is definitely feasible (for some ideas, see this month's Circuit Cellar, "Build a Powerline Carrier-Current Modem," on page 36) but in a large building, one must be sure that all of the offices are supplied from a common power transformer. Otherwise the signal will not be received at the other end. The readout can be virtually any device, and function keys could be added for return messages. In short, your idea can be easily accomplished with some custom hardware.

My choice would be to invest in some 9-inch video terminals and have one on each desk. They can be hard-wired together or connected via signals through the power line. These new terminals are not very expensive and are very chic and proper on an executive's desk in this day and age. Also, they can serve as terminals for electronic mail,

stock market quotes, or whatever data your company may require.

With the increased usage of computers in the office, a small investment now will pay off very quickly and will allow easy expansion to more sophisticated systems. . . . Steve

FFTs on Home Computers

Dear Steve,

I would like to know how to analyze audio signals using FFT (fast Fourier transform) programs. I am also interested in phase shift, group delay, and similar concepts. **Keith Russell**
Pullman, WA

An excellent article on the theory and applications of fast Fourier transforms appeared in the December 1978 BYTE. (See "Fast Fourier Transforms on Your Home Computer" by W. D. Stanley and S. J. Peterson, page 14.) In addition, a BASIC program for the spectral analysis of an input signal was included in the article. . . . Steve

Reformatting PDP/11

Dear Steve,

Do you know of any way that a microcomputer running the CP/M operating system can access floppy disks intended for a DEC (Digital Equipment Corporation) PDP/11 running the RT-11 operating system? I guess there are several levels to consider: the first might simply be the capability of reading disk data files; the second might be to read high-level language source programs and either run them, modify them to run, or just make them available for editing. Another consideration and probably most useful (i.e., hardest) would be a capability to use Z80

machine-language programs either by translating them or emulating a CP/M machine. Thank you for your help. **Barbara Olsen**
Belchertown, MA

I know of two programs, called Reformatter, that will allow reading and writing IBM 3740- or DEC RT-11-formatted disks on a CP/M system. They feature bidirectional data transfer and full directory manipulation. The programs can be obtained from Microtech Exports Inc., Suite 2, 467 Hamilton Ave., Palo Alto, CA 94301, (415) 324-9114. Each program costs \$249 and is available from stock. . . . Steve

BASIC Input Control

Dear Steve,

I recently purchased a Sinclair ZX81, and I find its features to be surprisingly numerous. I realize that the computer is very limited, but I don't know much about electronics, so I really don't know how limited it is.

I have been trying to write some game programs, but my efforts have been stymied by the fact that I can't figure out a way to keep from breaking the run of the program while still allowing input from the keyboard. I have been told that it requires a PEEK statement; however, I have found no listing in the programming guide that tells me how to do this. Where can I find this information? **Bruce Ward**
Noblesville, IN

On page 92 of your Sinclair ZX81 BASIC Programming Manual, you'll find the function INKEY\$. This function reads the keyboard and can be inserted in your game program to give you the input control that you need. (See listing 1.)

By inserting such a routine in your program and having your program loop by every few in-

Listing 1: An example of the function INKEY\$ in ZX81 BASIC.

```

100 LET A$=INKEY$
105 REM PRESS T TO TURN OBJECT ON SCREEN
110 IF A$="T" THEN GOTO 200
115 REM PRESS S TO STOP OBJECT ON SCREEN
120 IF A$="S" THEN GOTO 300
.
.
.
200 TURN ROUTINE
.
.
.
300 STOP ROUTINE
.
.
.
ETC

```

structions, you can monitor the keyboard for instant input to change the action. . . . Steve

Two in the Hand

Dear Steve,

I own a TRS-80 Model I and would like to buy the documentation to Visicalc. What books would you suggest? Also, I want to buy a second floppy-disk drive. Should I buy a 40-track unit when all of my disks have been formatted on a 35-track drive?

Ian Buda
Flushing, NY

An excellent book for Visicalc documentation is *The Power of Visicalc*, by Robert Williams and Bruce Taylor (Management Information Source, 1626 North Vancouver Ave., Portland, OR 97227).

A 40-track unit will work fine with 35-track formatted disks. The 40-track unit will simply have five extra tracks. The disk-controller hardware and/or software controls the head position of the disk, so you will not automatically gain additional storage when you plug in the new drive. . . . Steve

Inexpensive Homebrew Terminals

Dear Steve,

I am trying to put together an inexpensive terminal to

use a local university's computer from my home. My target expense is \$200. After reading your articles on the Comm-80 ("I/O Expansion for the TRS-80," June 1980 BYTE, page 42) and "A Build-It-Yourself Modem for Under \$50" (August 1980 BYTE, page 22), I've come up with a few ideas:

Get the Sinclair ZX81, build the appropriate serial interface and modem; or I can get an RCA 606 serial keyboard and build the required video interface and modem.

I would appreciate it if you could provide me with some better sources for my project.

Bill Chau
San Francisco, CA

Your goal of an under-\$200 terminal can be achieved in several ways. The use of the Sinclair ZX81 with a modem and serial interface is an excellent idea and offers the ability to add "smart terminal" capability if it becomes necessary. It appears to be the easiest to construct and debug.

The RCA 606 serial keyboard with modem and video interface will also achieve your goal but requires more building and debugging time. Your time and available test equipment may figure in your decision.

In my February 1983 Circuit Cellar article, I described a low-cost terminal for use with the Z8 microcomputer. (See "Build a

Handheld LCD Terminal," page 54.) It featured a one-line LCD display and should fall within your \$200 limit if you are frugal. I am not certain, however, if the small display is acceptable for your needs.

You may also want to consider the Skul-Tek terminal kit. It is a circuit board that, when assembled, provides all the electronics for an 80-line by 24-character video terminal. It is available for

\$179 from Romac Computer Equipment, 240 West Market St., POB 589, Somonauk, IL 60552. One drawback is that you would still need to buy a video monitor, so the total may be beyond your budget. John Bell Engineering sells a similar unit that costs \$199.95 assembled and tested. Contact John Bell Engineering Inc., 1014 Center St., San Carlos, CA 94070, (415) 592-8411. . . . Steve ■

In "Ask BYTE," Steve Ciarcia answers questions on any area of microcomputing. The most representative questions received each month will be answered and published. Do you have a nagging problem? Send your inquiry to:

Ask BYTE
c/o Steve Ciarcia
POB 582
Glastonbury CT 06033

If you are a subscriber to The Source, chat with Steve (TCE317) directly. Due to the high volume of inquiries, personal replies cannot be given. Be sure to include "Ask BYTE" in the address.

BYTEK's SECOND GENERATION UNIVERSAL (E)PROM PROGRAMMER—SYSTEM 15

Features:

- Bipolar PROMS.
- Micros - (8741, 48, 49, 51, 55A)
- I/O - 6 baud rates, 13 formats including Intellec, Textronix and Motorola.
- EPROMs, (2708 - 27256)
- Gang option - programs eight at once.
- Remote control standard.

\$15-R
\$695

PROGRAMS
OVER 250
DEVICE TYPES

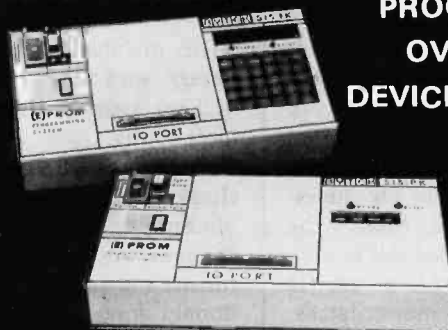

FUNCTIONS:

DISPLAY DEVICE DATA
EDIT RAM DATA
DEVICE PROGRAM
TYPE SELECTION

CRC-RAM
LOAD DATA
COMPARE FIELDS
FILL MEMORY FIELD
BLOCK MOVE
DIAGNOSTICS
and more.



BYTEK

COMPUTER SYSTEMS CORP

4089 S. Rogers Circle #7 Boca Raton, FL 33431 (305) 272-2051

Clubs and Newsletters

Fortune in the Bay Area

A nonprofit users group for owners of the Fortune 32:16 computer (*fug*) meets regularly in the San Francisco Bay Area and produces a newsletter entitled *Fortune Users Group*. New members are welcome. For further details, write to Ned Hamilton, (*fug*), POB 1501, Lafayette, CA 94549, or call (415) 283-1885.

Apple III Users Group

Adam's Apple, a nonprofit organization for Apple III users, offers a free first-year membership and graphic software to all Apple III owners. For information, send a large self-addressed, stamped envelope to David Adams, Adam's Apple III, POB 3151, Redwood City, CA 94064.

Northern VA Atari Users

NOVATARI, an Atari users group in Northern Virginia, meets on the second Sunday of the month in Chantilly, Virginia. Members have access to a program library of disks and tapes. Annual dues are \$15 and include a subscription to the newsletter, *Current Notes*. The newsletter is available to non-members for \$12 a year (12 issues). For more details, contact Tim Kilby, NOVATARI Users Group, Rt. 1, Box 288-B, Sperryville, VA 22740.

Newsletter Focuses on Home Control

The *Microcomputer Home Control Newsletter* is a quarter-

ly publication that covers hardware and software applications for home control: telecommunications, security, monitoring utilities, and evaluations of new products. It costs \$9.97 a year. For information, write to Russ Eberhart, POB 797, Columbia, MD 21044.

Overseas Communication

The Japan Microcomputer Club in Tokyo welcomes new members, user group information, and newsletters from microcomputer users groups from around the world. For details, contact Keigo Aono, Japan Microcomputer Club, Room 313, 3-5-8 Shibakoen, Minato-Ku, Tokyo 105, Japan, tel.: 03-438-1869 or Telex: CICC J27544.

Amarillo Apples

Apple Information and Data Exchange (AIDE), an affiliate of the International Apple Corps (IAC), meets on the second Thursday of each month at 7 p.m. at Amarillo College in Amarillo, Texas. AIDE maintains a software library and a cooperative bulletin board that is open to local clubs, (806) 374-9711. Annual dues are \$15 and include a subscription to a bimonthly newsletter. Exchanges are welcome. For further information, contact Ronald Jones, AIDE, POB 30878, Amarillo, TX 79120, or call (806) 352-7934.

Ventura County, California

The Cabrillo Computer Club (formerly the Ventura County TRS-80 Computer

Club) produces a monthly newsletter, *Micro Info Exchange*, and supports a bulletin-board service, called the Data Express, that has more than 40 programs. The club meets monthly and sponsors a 24-hour dedicated phone line and occasional swapmeets. For details, write to Glenn Bennett, Cabrillo Computer Club of Ventura County, POB 3032, Camarillo, CA 93011.

Meet In the Southeast of Michigan

General meetings of the South Eastern Michigan Computer Organization (SEMCO) are held each month. SEMCO is a nonprofit organization and charter member of the Midwest Affiliation of Computer Clubs (MACC). A \$10 annual membership entitles you to a subscription to SEMCO's newsletter, *Data Bus*. Newsletter exchanges are welcome. All correspondence relative to SEMCO may be addressed to SEMCO, POB 02426, Detroit, MI 48202; inquiries about the newsletter should be addressed to *Data Bus*, Frank Voss, POB 43, Wyandotte, MI 48192.

Computerists Meet In San Diego

Anyone interested in computing is welcome to attend the monthly meetings of the San Diego Computer Society. The club maintains a community bulletin-board system for use by members and produces a monthly newsletter, *Personal Systems*. Annual membership costs \$15 in the U.S., \$25 overseas, and in-

cludes a subscription to the newsletter. For further information, write to the San Diego Computer Society, POB 81537, San Diego, CA 92138.

International Science Exchange

The Scientific Microcomputing Association at the University of Lyon in France welcomes any scientific computer users, particularly Apple users. Scientists are encouraged to exchange information about scientific calculations, graphics, languages, computer communications, and experiments. For information, contact Dr. Yves Boudeville, IRC-CNRS, 2 Avenue Albert Einstein, 69626 Villeurbanne, Cedex, France.

Hardcore Computing In the Northwest

Hardcore Computing, a newsletter produced every month by Softkey Publishing, contains software reviews, technical notes, and programs. Subscriptions are \$20 in the U.S., \$29 in Canada; foreign rates vary. Sample copies are available for \$5 in the U.S. and \$8 elsewhere. For details, write to *Hardcore Computing*, Softkey Publishing, POB 44549, Tacoma, WA 98444, or call (206) 581-6038.

Educators: Save Time

The Digest of Software Reviews: Education is a quarterly journal containing abstracts of selected, indexed reviews on educational software packages. Annual subscriptions are \$43.95; discounts are available for

schools, colleges, and educators. For information, contact *The Digest of Software Reviews: Education*, School and Home Courseware Inc., Suite C, 1341 Bulldog Lane, Fresno, CA 93710, or call (209) 227-4341.

For Elementary and High Schools

The National Educational Computer Library (NECOL) is a nonprofit educational organization dedicated to assisting schools nationwide in meeting computer needs. The organization produces the *National Educational Computer Review* five times a year. For further details, write to the National Educational Computer Library, POB 293, New Milford, CT 06776, or call (203) 354-7760.

CPUP News from ETUG

The ET-3400 Users Group (ETUG) is a nonprofit, independent source of information about the Heath Company ET/ETA-3400 microprocessor trainer. Both new and experienced computer users are invited to become members. Dues are \$16 in the U.S. and Canada and \$22 elsewhere. Membership entitles you to receive the quarterly newsletter, *CPUP News*. Submitted articles and newsletter exchanges are welcome. Write to ETUG, 11231 Oak St., El Monte, CA 91731.

ETUG Chapter In Los Angeles

Owners of the Heath Company ET/ETA-3400, who live in southern California, can attend monthly meetings of the Los Angeles Chapter of the ET-3400 Users Group

(LAETUG) at the Heathkit Electronic Center, 2309 South Flower, Los Angeles, CA 90007. For further information, call Gilbert Murillo at (213) 749-0261.

Electronic Business Bonus

Computer Comps provides programs and information for real-estate professionals, appraisers, investors, syndicators, brokers, managers, and attorneys. The \$20 annual membership fee includes a newsletter, access to a database, electronic mail, Telex services, and group purchase discounts. For details, call Jim Clyde at (914) 358-2335 or 358-7102 (computer), or write Computer Comps, 48 Burd St., Nyack, NY 10960.

Atari Group on North Shore

Owners and users of the Atari 400/800 personal home computer are welcome to join a group on the Massachusetts North Shore. Users exchange information on getting the most from their Atari. For details, send a self-addressed, stamped envelope to the North Shore Atari Computer Users Group, POB 2052, West Peabody, MA 01960, or call Joseph Birkner at (617) 535-3749.

Informed Apple Users

The Central Ill Apple Users Group (CIA) meets on the second Tuesday of each month at 6:30 p.m. in the Peoria Public Library in Peoria, Illinois, to discuss Apple-related topics. A newsletter, the *CIA Informer*, is produced and newsletter exchanges are welcome. For

details, contact the Central Ill Apple Users Group, POB 1462, Peoria, IL 61602.

GTE Telenet Reports

The *GTE Telenet Report* is a monthly tabloid produced by GTE Telenet Communications Corporation that contains national and international news on communications. For details, write to the GTE Telenet Communications Corp., 8229 Boone Blvd., Vienna, VA 22180.

Big K, Little k

Little k is a bimonthly newsletter produced by Poundfoolish Publications for pocket-computer users. It includes reviews of tested programs, software, and information for program authors. A sample issue is \$1.50; an annual subscription is \$12. For information, write to *Little k*, POB 75, Dubuque, IA 52001.

If you would like BYTE readers to know about your club or newsletter send the details accompanied by no more than one newsletter to Clubs and Newsletters, BYTE Publications, POB 372, Hancock, NH 03449. Overseas groups are encouraged to participate. Please allow at least three months for your announcement to appear.

BYTE's Bits

TI to Service Tymshare Equipment

In mid-March, Tymshare entered an agreement with Texas Instruments whereby TI will handle maintenance calls and equipment repairs for users of Tymshare-supplied equipment. For repair work, users can call (800) 231-3128, or in Texas, (800) 572-3300, 24 hours a day, 7 days a week. Because Tymshare supplies its customers

Atari Users Meet In West Valley

The West Valley Atari Users Group (WVAUG) welcomes users of Atari computers. Separate monthly meetings are held for both experienced and novice users. Membership dues are \$12 a year, which includes a monthly newsletter, access to the disk library maintained by the club, and discounts on purchases. For details, contact Larry Stemke, WVAUG, 19400 Lemay St., Reseda, CA 91335.

Long Islanders Meet

An IBM Personal Computer users subgroup of the Long Island Computer Association (IBM PC LICA) meets on the second Friday of every month on the campus of the New York Institute of Technology, Commack, New York, in room 10. For details, contact Marvin Friefeld, 3 Lyndron Ave., Smithtown, NY 11787, or call (516) 724-0574 between 5 and 10 p.m. weekdays. ■

with computer hardware from a variety of manufacturers, this single-source maintenance service frees users from having to locate several different companies when problems arise.

Tymshare is an international telecommunications and information-management company. Corporate headquarters are located at 20705 Valley Green Dr., Cupertino, CA 95014, (408) 446-6000. ■

Software Received

Apple

Alcor Pascal, a compiled language. This implementation of the Pascal language requires that programs be translated to an object format. It includes guides, a tutorial, and a master index. For the Apple II with CP/M; floppy disk, \$199. Alcor Systems, 800 West Garland Ave. #204, Garland, TX 75040.

The Bank Street Writer, a children's word-processing program. This classroom-oriented program makes it easier to type, revise, store, retrieve, and print text. Three disks are included with documentation, a teacher's reference guide, and a section for students. For the Apple II and IIe; floppy disk, \$95. Scholastic Inc., 730 Broadway, New York, NY 10003.

Boa, an arcade-type game. Recover the jewel of your king hidden in mazelike caverns using high-resolution graphics, sound effects, and a continuous musical score. For the Apple II; floppy disk, \$29.95. Micro Magic, Suite C, 908 Memorial Parkway NW, Huntsville, AL 35801.

Chargen V1.0, a character-generator program for television production. It includes a production display program and an automatic display program for bulletin-board type applications. For the Apple II; floppy disk, \$125. Boston Media Consultants, 19 Damon Rd., Scituate, MA 02066.

College Directions, a program that helps college-bound individuals choose from 1300 four-year colleges and universities based on individual interests and college assessments. For the Apple II

and II Plus; floppy disk, \$250. Systems Design Associates Inc., 723 Kanwha Blvd. E, Charleston, WV 25301.

The Dark Crystal, a fantasy-adventure game in which you journey through a make-believe land. Using the computer as your hands, feet, eyes, and ears you must restore a shard of the crystal to its place and solve a series of puzzles. For the Apple II and II Plus; floppy disk, \$39.95. Sierra/On-Line Inc., 36575 Mudge Ranch Rd., Coarsegold, CA 93614.

File-Fax 2.0, a database-management program that includes user-friendly applications such as inventory control, customer files, mailing lists, purchase records, and more. For the Apple II and II Plus; floppy disk, \$149. TMQ Software Inc., 82 Fox Hill Dr., Buffalo Grove, IL 60090.

Financial Facts, a series of tools that instantly computes the majority of data needed in personal and small-business financial management. It contains 20 programs including up-to-date depreciation methods. For the Apple II and II Plus; floppy disk, \$59.95. Howard W. Sams & Co. Inc., 4300 West 62nd St., Indianapolis, IN 46268.

Krell's College Board SAT Preparation Series, an educational-testing program. Prepare students for high school SAT exams by diagnosing skill areas and planning drill and practice in the areas where the student needs it most. For the Apple II; floppy disk, \$299.95. Krell Software Corp., 1320 Stony Brook Rd., Stony Brook, NY 11790.

The Latin Hangman, an educational game. This variation

on the Hangman game teaches Latin words and terminology. For the Apple II; floppy disk, \$29.95. George Earl, 1302 South General McMullen, San Antonio, TX 78237.

Math Blaster, an educational program that develops basic mathematical skills in students ages 6 through 12. It contains 600 problems in math functions, fractions, and percents as well as an editor and an arcade game. For the Apple II, II Plus, and IIe; floppy disk, \$49.95. Davidson and Associates, 6069 Groveoak Place #14, Rancho Palos Verdes, CA 90274.

The Missing Ring, an arcade-type game. Many have searched for the wizard's ancient ring and lived to regret it. Find your way through a maze, solve the mystery, and claim the Missing Ring. For the Apple II; floppy disk, \$29.95. Data-most Inc., 8943 Fullbright Ave., Chatsworth, CA 91311.

Money Tool, a money-management program that provides a complete report of your spending pattern. It allows allocation of funds for fixed expenses, semi-fixed costs, and determines how much is left for discretionary purchases. For the Apple II Plus; floppy disk, \$59.95. Howard W. Sams & Co. Inc. (see address above).

Music Games, a package of twelve colorful games useful in mastering the art of music by training students of all ages to recognize musical notes and rhythms both visually and audibly. For the Apple II Plus; floppy disk, \$39.95. Howard W. Sams & Co. Inc. (see address above).

The Pascal Toolkit, a utility package that contains a character generator, an image-creation utility, DOS-to-Pascal conversion in both text and pictures, and a new library unit called Grafix-stuff. For the Apple II, II Plus, and IIe; floppy disk, \$24.95. Wize Buys, POB 1588, Orem, UT 84057.

Pinball Paradise, four pinball-simulation games. For the Apple; floppy disk, \$24.95. Golden Knight Software, 11 Lark Lane, Huntington, CT 06484.

Pinball Paradise II, four different pinball-simulation games. For the Apple; floppy disk, \$24.95. Golden Knight Software (see address above).

SAUCE, this high-level programming language allows you to run applications that result in increased productivity. For the Apple II Plus and IIe; floppy disk, \$400. Sonora Enterprises, POB 4841, Albuquerque, NM 87196.

Scoreboard. A program that records and displays game scores in large graphic characters on the screen. It can display up to eight names of players who are tied or winning. For the Apple II Plus and IIe; floppy disk, \$17.95. Rosecom Computer Products, 604 East Arcadia, Peoria, IL 61603.

Spectre, an arcade-type game. While you're lost in outer space, the Questers, the most vicious life form in the universe, are swarming through space ports seeking to destroy you. Think and act quickly if you hope to survive. For the Apple II or II Plus; floppy disk, \$29.95. Datamost (see address above).

Star Maze, an arcade-type game in which you must find

the 9 power jewels in each of 16 levels of the maze and return them to your mother-ship. Avoid or destroy alien ships with bullets or a limited supply of antimatter bombs. For the Apple II; floppy disk, \$34.95. Sir-tech Software Inc., 6 Main St., Ogdensburg, NY 13669.

Atari

A.E., an arcade-type game. Squadrons of menacing sting rays are attacking you and eluding your missiles. You will be doomed unless you can chase them into outer space. Requires a joystick. For the Atari 400/800; floppy disk, \$34.95. Broderbund Software Inc., 1938 Fourth St., San Rafael, CA 94901.

Crisis Mountain, an arcade-type game. Your mission is to defuse bombs planted by terrorists in the treacherous caverns of an active volcano. To reach them you must go through a maze avoiding boulders, tunnels, lava, and a radioactive bat. Requires a joystick. For the Atari 400/800; floppy disk, \$34.95. Synergistic Software, Suite 201, 830 North Riverside Dr., Renton, WA 98055.

G.I. Joe Cobra Strike, an arcade-type game. The headquarters of the Special Mission Forces is under siege by the archenemy, Cobra, an evil organization determined to take over the world. To defend the camp, you must destroy the cobra. For the Atari 2600; cartridge, \$30. Parker Brothers, 50 Dunham Rd., Beverly, MA 01915.

No Escape, an arcade-type game. Jason has taken the Golden Fleece and angered the gods of Olympus. Imprisoned in the Temple of Aphrodite and armed with stones and magic bricks, Jason must fight frenzied

Furies. For the Atari 2600; cartridge, \$29.95. Imagic, 981 University Ave., Los Gatos, CA 95030.

Repton, an arcade-type game. As you take over the controls of the Star Fighter *Armageddon*, the Quarriors are attacking Repton. Stop them using your laser gun, nuke bombs, radar screen, and energy shield. For the Atari 800 and 1200; floppy disk, \$39.95. Sirius Software Inc., 10364 Rockingham Dr., Sacramento, CA 95827.

Sky Blazer, an arcade-type game. You'll need the WWIII jet to clear away radar stations, avoid supersonic tanks, find and destroy ICBM installations, and escape missiles as you make your final bomb run on the Bungeling Empire headquarters. Requires a joystick. For the Atari 400/800; floppy disk, \$31.95. Broderbund Software Inc. (see address above).

Sky Skipper, an arcade-type game. The sky's the limit for young players as they control a dive-bombing plane on a daredevil rescue mission. Pilots come to the aid of helpless kittens, turtles, ducks, and rabbits held captive by gorillas. For the Atari 2600; cartridge, \$30. Parker Brothers (see address above).

Strawberry Shortcake, an arcade-type game for ages 4 to 7. The Purple Pieman cast an evil spell on Strawberry Shortcake and all her friends. Now everyone has a body that's all mixed up. See if you can put Strawberryland characters back together again. For the Atari 2600; cartridge, \$30. Parker Brothers (see address above).

Telengard, an arcade-type game. You control a character who must descend to the depths of Telengard and battle monsters. Gain strength

by finding enchanted items. Six levels of play. For the Atari 800; cassette, \$23. The Avalon Hill Game Co., 4517 Harford Rd., Baltimore, MD 21214.

Commodore

Bartender's Friend, a bar-recipe guide and liquor term-definer program. This automated program contains hundreds of recipes and bar terms. For the Commodore 64; cassette, \$9.95. Raymond L. Reynolds, 384 Hyacinth St., Fall River, MA 02720.

Practicalc, an electronic-spreadsheet program that lets you perform bookkeeping operations, several mathematical functions, and projections. You can enter titles and numerical data into rows and columns. For the Commodore VIC-20; cassette, \$39.95. Micro Software International Inc., 50 Teed Dr., Randolph, MA 02368.

Programmable Characters Package. With these three programs, Single-Edit, Multi-Edit, and Data Generator, programmable characters can be designed either singly or in up to 5 by 5 blocks. Requires a joystick. For the Commodore VIC-20; cassette, \$14.95. Sunshine Software, POB 473, Portage, MI 49081.

Telengard, an arcade-type game (see description under Atari). For the Commodore 64 and PET 2001; cassette, \$23. The Avalon Hill Game Co., 4517 Harford Rd., Baltimore, MD 21214.

IBM Personal Computer

Cross Reference Utility, a programming aid that provides the BASIC programmer with a complete reference listing of variables within a

BASIC program. You can review, analyze, and modify the program to maximum capability. For the IBM Personal Computer; floppy disk, \$29.95. Prentice-Hall Software Inc., Route 9W, Englewood Cliffs, NJ 07632.

Night Mission Pinball, a simulated pinball game in which your plane is in a World War II night bombing run. Use up to four balls and flippers to score in a playfield with five bumpers, seven targets, nine rollovers, and two spinners. For the IBM Personal Computer; floppy disk, \$39.95. Sublogic Corp., 713 Edgebrook Dr., Champaign, IL 61820.

PL/I-86, an implementation of the PL/I language based on the ANSI General Purpose Subset. The package includes a reference manual, programming guide, and command summary. For the IBM Personal Computer; floppy disk, \$750. Digital Research, POB 579, 160 Central Ave., Pacific Grove, CA 93950.

Peachtext 5000, a package that combines word processing, financial planning, and simple database management features for a complete personal-productivity system. It incorporates Random House Electronic Thesaurus, the Peachcalc electronic spreadsheet, and more. For the IBM Personal Computer; floppy disk, \$395. Peachtree Software Inc., 8th Floor, 3445 Peachtree Rd. NE, Atlanta, GA 30326.

Pie:Writer, a word-processing package that includes split-screen editing, full use of the keyboard, and customized function-key support. This program can process two files at once and provides virtual-file storage. For the IBM Personal Computer; floppy disk, \$199.95. Hayden Software Co., 600 Suffolk St., Lowell, MA 01853.

The Screen Generator, a screen-management program that provides a generalized method to design, build, and change screens in minutes for computer applications. It can be used to build screens "outside" of the application because all screen information is stored and updated on libraries external to your programs. For the IBM Personal Computer; floppy disk, \$125. K & S Systems, POB 643, Drexel Hill, PA 19026.

SmarTerm/PC, a terminal-emulator program that lets your IBM Personal Computer function like a Digital Equipment Corporation VT100, VT101, VT102, or VT52 terminal. It implements features such as setup mode, character attributes, line and character insert and delete, and full local printer support. For the IBM Personal Computer; floppy disk, \$150. Persoft Inc., 2740 Ski Lane, Madison, WI 53713.

Stock Portfolio Reporter, a program that gives investors current information on as many as 100 stock accounts. Market prices can be updated automatically from log-on to log-off using Dow Jones News/Retrieval. For the IBM Personal Computer; floppy disk, \$179. Micro Investment Systems Inc., POB 8599, Atlanta, GA 30306.

TRS-80

Assignment: Europe, a travel-simulation game in which 10 players receive different travel assignments and must find the most efficient way to complete them using different communications between various cities in Europe. For the TRS-80 Models I and III; floppy disk, \$24.75. Triangle Software, POB 58182, Raleigh, NC 27658.

Banking, an investing game in which you try to generate the largest amount of income through the use of competitive marketing, careful expansion, and a well-chosen advertisement budget. For the TRS-80 Models I and III; floppy disk, \$29.75. Triangle Software (see address above).

Draw, a graphics and text program that lets you draw designs on the screen using cursor control keys, special commands, and automatic drawing routines. You can save displays on disk or in your own programs. For the TRS-80 Model III; floppy disk, \$29.95. Lichen Software, 6603 North Lee St., Spokane, WA 99207.

Fraction Math Quiz, a math-drill program that contains five levels of problems in fraction operations. Intuitive reasoning skills are encouraged by the multiple-choice format for students ranging from elementary to high school. For the TRS-80 Color Computer, cassette, \$14.95. Creative Technical Consultants, POB 652, Cedar Crest, NM 87008.

Kwikdraw, a fast graphics and text program written in machine code that lets you move, duplicate, and erase your designs of figures and/or text. Save and load displays in BASIC, ASCII, or object codes. For the TRS-80 Model III; floppy disk, \$74.95. Lichen Software (see address above).

Music**, a musical program that uses four simultaneous notes without additional hardware. This program includes two voices you select, tempo adjust, functional display of note position, more than four octaves, reserve storage for 2000 notes, and direct play from the keyboard. For the TRS-80 Color Computer; cassette, \$19.95.

Saffron Software, 5306 Birch Grove Dr., San Jose, CA 95123.

Propack, a machine-language package that gives you simple and foolproof access to your Profile files from a BASIC program. Assign a string array for each file to be used and address your files by logical record number or index keys. For the TRS-80 Model III; floppy disk, \$75. The Small Computer Co., Suite 1200, 230 West 41st St., New York, NY 10036.

Prosort, a data-organizer program that sorts data into almost any order for print, inquiry, and Superscript selection operations. The program, for use with Profile III+, includes five print indexes and an inquiry index. For the TRS-80 Model III; floppy disk, \$150. The Small Computer Co. (see address above).

Telengard, an arcade-type game (see description under Atari). For the TRS-80 Models I and III; cassette, \$23. The Avalon Hill Game Co., 4517 Harford Rd., Baltimore, MD 21214.

Other Computers

Clip, a CP/M utilities package that allows the user to store command files, edit lines and files, and use a built-in calculator program. It contains over 50 commands. For CP/M-based systems; floppy disk, \$49.95. Thoughtware Inc., Suite 4, 2450 East Speedway, Tucson, AZ 85719.

HexPrintR, a utility program for Wordstar that allows you to take advantage of the full capabilities of your printer. You can send any number of any type of characters to

your printer from any place in your text. For the Osborne 1; floppy disk, \$39. C.I. Software & Computer Products, 1380 Garnet Ave., E149, San Diego, CA 92109.

Hidden Palace. You assume the role of a treasure hunter trying to find a priceless vase amidst several dangers in an ancient jungle palace. For the Texas Instruments 99/4A; cassette, \$14.95. Innovative Data Co., 1041 Dan Kuykendall Cv., Memphis, TN 38111.

War Boats, a game in which you place your boats on a 10 by 10 grid and try to guess the positions of your opponent's boats. Sink boats with shots that are displayed graphically on the screen. For the Timex/Sinclair 1000; cassette, \$2.99. Computer Heroes, 1961 Dunn Rd., East Liverpool, OH 43920. ■

This is a list of software packages that have been received by BYTE Publications during the past month. The list is correct to the best of our knowledge, but it is not meant to be a full description of the product or the forms in which the product is available. In particular, some packages may be sold for several machines or in both cassette and floppy-disk format; the product listed here is the version received by BYTE Publications.

This is an all-inclusive list that makes no comment on the quality or usefulness of the software listed. We regret that we cannot review every software package we receive. Instead, this list is meant to be a monthly acknowledgment of these packages and the companies that sent them. All software received is considered to be on loan to BYTE and is returned to the manufacturer after a set period of time. Companies sending software packages should be sure to include the list price of the packages and (where appropriate) the alternate forms in which they are available.

Event Queue

August 1983

August

Engineering Summer Conferences, Chrysler Center for Continuing Engineering Education, North Campus, University of Michigan, Ann Arbor. Two of the seven courses offered this month are "Software Design Techniques and Ada" and "Operations Research and the Management Sciences: Methods and Tools." The fees are \$600 and \$675, respectively. For course outlines and registration details, contact Engineering Summer Conferences, 200 Chrysler Center, North Campus, University of Michigan, Ann Arbor, MI 48109, (313) 764-8490.

August

Unix Seminar, various sites throughout Canada. This three-day seminar serves as an introduction to the Unix operating system. It includes discussions of standard user-level programs and commands for file manipulation, word processing, and programming. The pros and cons of Unix for specific applications and such application areas as database and real-time processing, data communication, and office automation are explored. The fee is \$645. For information, contact the Center for Advanced Professional Education Inc., 11928 North Earlham, Orange, CA 92669, (714) 633-9280.

August-September

How to Document a Computer System as It Is Being Developed, various sites throughout the U.S. and Canada. This one-day workshop presents a series of simple procedures that can be followed in recording the results of each task performed during the development of

a computer system. The fee is \$155. Contact Technical Communications Associates, Suite 210, 1250 Oakmead Parkway, Sunnyvale, CA 94086, (800) 277-3800, ext. 977; in California, (800) 792-0990, ext. 977.

August-September

Local Networks: Promise Into Practice, various sites throughout the U.S. This two-day seminar will focus on the criteria for designing and choosing local networks and the experiences that users have had in selecting and installing local networks. The fee is \$595. Full details are available from Architecture Technology Corp., POB 24344, Minneapolis, MN 55424, (612) 935-2035.

August-October

Repair of Microcomputer-based Equipment, various sites throughout the U.S. and Canada. This lecture/laboratory sequence is intended for field-service personnel; engineers, and technical writers. The seminar describes general servicing practices that are applied to the subsystems of any microprocessor family. For further information, contact the Registrar, Testek Consultants Inc., 1000 North Patton St., Arlington Heights, IL 60004, (312) 577-2134.

August-November

Applying the New Tools for Profit and Cash Flow Planning: Graphics and Personal Computers, various sites throughout the U.S. This two-day course is designed to help certified public accountants improve and expand management advisory services by using new graphics tools to improve managers' understanding and use of financial planning. A special type of graph designed for financial planning and de-

cision making will be featured. Fees range from \$225 to \$295. For more information on the course, contact the Purcell Letter on Graphics for Management, POB 06008, Columbus, OH 43206, (614) 444-6571. For a course schedule and registration details, contact Matthew Malok, American Institute of Certified Public Accountants, 1211 Avenue of the Americas, New York, NY 10036, (212) 575-3848.

August-December

IEEE Conferences and Meetings, various sites around the world. The Institute for Electrical and Electronics Engineers (IEEE) sponsors conferences, meetings, and workshops covering high-technology issues. For details, contact the IEEE Computer Society, Suite 300, 1109 Spring St., Silver Spring, MD 20910, (301) 589-8142.

August-December

Intensive Two-Day Seminars for Professional Development, Worcester Polytechnic Institute, Boston metropolitan area, and Hartford and Stamford, CT. Among the seminars being offered are "The Engineer as Manager," "Inventory Control: Using Computers," and "Fundamentals of Data Processing." For in-house seminar information, call Robert J. Hall at (617) 793-5574. For a seminar bulletin and registration information, contact Ginny Bazarian, Office of Continuing Education, Higgins House, Worcester Polytechnic Institute, Worcester, MA 01609, (617) 793-5517.

August-December

Systems Development Documentation: Forms Method, various sites throughout the U.S. and Canada. This one-day seminar is designed for

data-processing managers, project leaders, programmers, and technical writers. Topics to be covered include system design documentation, format and style guidelines, and options for end-document publication. The course fee is \$155, which includes all materials. In-company presentations are available for groups of 10 or more. For details, contact Technical Communications Associates Inc., 1250 Oakmead Parkway #210, Sunnyvale, CA 94086, (800) 227-3800, ext. 977; in California, (800) 792-0990, ext. 977, or (408) 737-2665.

August 10-12

Microcomputers and High Technology in Vocational Education Conference, Concourse Hotel, Madison, WI. Beginning and advanced classes on microcomputers, presentations on vocational education programs, and software exhibits will be featured. For details, contact Judy Rodenstein or Roger Lambert, Vocational Studies Center, 964 Educational Sciences Building, University of Wisconsin, 1025 West Johnson St., Madison, WI 53706, (608) 263-4367 or 263-2704.

August 11-13

Personal Computer Interfacing and Scientific Instrument Automation, Williamsburg, VA. This workshop provides each participant with hands-on experience in wiring and testing interfaces. The fee is \$395. Call or write Dr. Linda Leffel, C.E.C., Virginia Polytechnic Institute and State University, Blacksburg, VA 24061, (703) 961-4848.

August 15-17

Small Computers in Criminal Justice Agencies, Cincinnati, OH. This conference is designed to help beginners un-

derstand and appreciate the use and application of micro-computers in criminal justice agencies. The fee is \$285, which includes luncheons, continuing education units, and materials. Contact Carol Strand, Anderson Publishing Co., 646 Main St., POB 1576, Cincinnati, OH 45201, (800) 543-0883; in Ohio, (800) 582-7295.

August 15-19

Advanced C Topics Seminar, New York, NY. Practical topics for C programmers are covered in this course offered by Plum Hall Inc. Areas of interest include portability, efficiency, readability, debugging, packaging, and interfacing. For further details, contact Joan Hall, Plum Hall Inc., 1 Spruce Ave., Cardiff, NJ 08232, (609) 927-3770.

August 15-19

Managing People, Productivity, Projects, Profitability, Worcester Polytechnic Institute, Worcester, MA. This course covers the entire management spectrum from communications and negotiating to controlling particular projects. The fee is \$975. Contact Kathy Shaw, Office of Continuing Professional Education, Worcester Polytechnic Institute, Worcester, MA 01609, (617) 793-5517.

August 16-17

Polymer Materials for Electronic Applications, Hyatt Rickey's Hotel, Palo Alto, CA. The fee for this short course is \$395. For information, contact Continuing Education in Engineering, Department 622N, University of California Extension, 2223 Fulton St., Berkeley, CA 94720, (415) 642-4151.

August 16-19

Landsat: Sensor Design & Operation, University of California, Santa Barbara. This course is intended for users of remote-sensor data,

including geographers, geologists, and engineers. It covers such topics as sensor requirements and user needs, sensor-design principles and tradeoffs, and multispectral-scanner and thematic-mapper operation. It's cosponsored by the Santa Barbara Research Center and the National Oceanic and Atmospheric Administration. The fee is \$450. For a brochure, contact J. Weisman, University of California Extension, Santa Barbara, CA 93106, (805) 961-3697.

August 17-19

SNA and Teleprocessing Access Methods, Hyatt Regency, New Brunswick, NJ. This course traces the evolution of data-communications software. Topic areas include host-control software requirements and SNA (system network architecture) concepts, protocols, and implementations. The registration fee is \$645. Full details are available from the Center for Advanced Professional Education, 11928 North Earlham, Orange, CA 92669, (714) 633-9280.

August 18-19

Computer Literacy for Lawyers, Denver, CO. This seminar is intended to introduce attorneys to basic computer concepts and their application to the practice of law. Topics will include the specific uses, costs, and benefits of using computers in legal practice. The fee is \$550, which includes reference materials. Group discounts are available. For further information, contact Kathryn Mann, Center for Legal Studies, 1926 Arch St., Philadelphia, PA 19103, (215) 732-6999.

August 19-21

The Second Annual National Heath Users Group (HUG) Conference, Hyatt Regency O'Hare, Chicago, IL. A products display and seminars on

topics of interest to Heath/Zenith users will be featured. Contact HUG, Hilltop Rd., St. Joseph, MI 49085, (616) 982-3463.

August 20

The First Annual Ham & Chip Flea Market, La Salle College, Philadelphia, PA. Computer software, hardware, ham radio, electronics, and sound equipment will be featured. Contact the Philadelphia Area Computer Society, POB 1954, Philadelphia, PA 19105, (215) 951-1255.

August 21-26

The Fourth World Congress on Medical Informatics-MEDINFO 83, RAI International Congress and Exhibition Centre, Amsterdam, The Netherlands. This event combines scientific, technical, and social programs. Approximately 300 scientific papers will be presented on health and hospital systems, clinical laboratory systems, imaging, nursing applications, and preventive and occupational care. Demonstrations, product exhibits, film and video sessions, tours, workshops, and special-interest meetings will be held. The conference language will be English. Further details are available from the MEDINFO 83 Congress Office, Enschedepad 41-43, NL-1324 GB Almere-Stad, The Netherlands.

August 22

The Revolution in Telecommunications Technologies: Integrating Telecommunications Into Corporate Strategy, Worcester, MA. This executive briefing outlines specific ways to reduce communications costs and offers techniques for developing a basis of integration and planning among various parties within an organization. The fee is \$690. Information on in-house executive presentations is available from Robert

J. Hall at (617) 793-5574. For complete details, contact Ms. Ginny Bazarian, Office of Continuing Education, Worcester Polytechnic Institute, Worcester, MA 01609, (617) 793-5517.

August 22-26

The National Conference on Artificial Intelligence-AAAI-83, Washington Hilton Hotel, Washington, DC. This conference is sponsored by the American Association for Artificial Intelligence (AAAI). Displays of computer hardware and software, formal presentations, and the Fredkin Chess Prize Competition highlight this conference. Contact Claudia Mazzetti, AAAI, 445 Burgess Dr., Menlo Park, CA 94025, (415) 328-3123.

August 23

The Revolution in Telecommunications Technologies: Integrating Telecommunications Into Corporate Strategy, New York, NY. For details, see August 22.

August 23-24

Indycon '83, Convention Center, Indianapolis, IN. This conference and exhibition features more than 35 technical sessions and 300 exhibition booths devoted to microcomputers and electronic components. Contact Indycon '83, POB 40312, Indianapolis, IN 46260, (317) 875-7711.

August 24-26

SNA and Teleprocessing Methods, Marriott Hotel, Portland, OR. For details, see August 17-19.

August 25-26

Fundamentals of Data Processing for the Non Data-Processing Executive, Washington, DC. Major topics to be covered include computer technology, the functions of an information system, the development of applications

software, and the costs and benefits of information systems. This seminar is presented by the Wharton School of the University of Pennsylvania. The fee is \$795. In-house programs are available. For details, contact Wharton FDP Seminar, Registrar-Processing Center, 30-30 Borden Ave., Long Island City, NY 11101, (212) 392-9441.

August 26-28

Computers for Farm and Family, St. Paul, MN. This seminar and trade show, organized by the Minnesota Agricultural Extension Service and *The Farmer/Dakota Farmer* magazine, will be held in conjunction with the Minnesota State Fair. Featured will be exhibits, presentations, and educational sessions for experienced computer users and the novice farm and home computer user. Contact Sandra J. Becker, Office of Special Programs-XY, 405 Coffey Hall, University of Minnesota, 1420 Eckles Ave., St. Paul, MN 55108, (612) 373-0725.

August 26-28

The First IBM PC Faire, Civic Auditorium and Brooks Hall, San Francisco, CA. The focus of this fair will be on hardware, software, and applications for the IBM Personal Computer. Technical conferences, formal papers, product expositions, and special-interest group meetings will be held. For details, contact IBM PC Faire, 345 Swett Rd., Woodside, CA 94062, (415) 851-7077.

August 26-September 3

The International Telecommunications, Scientific, and Technical Expoconference-Telexpo China 1983, Foreign Trade Center, Guangzhou (Canton), Jiangxi Province, People's Republic of China. The theme of this communications-equipment show is

"An Integrated Telecommunications System for China." Displays will include aerospace equipment, computers, and peripherals. Additional information is available from AVP Expositions Co. Ltd., Suite 13, 13/F, Block A, Wahkai Industrial Center, 221 Texaco Rd., NT Hong Kong; tel: 0-239003; Telex: 40725 AVPEX HX.

August 28

The Tenth Annual Hamfest/Computerfest, Hershey, PA. This event, sponsored by the Central Pennsylvania Repeater Association, will feature a large indoor dealer and flea market area. For details, contact Timothy R. Fanus, WB3DNA, 6140 Chambers Hill Rd., Harrisburg, PA 17111, (717) 564-0897 between noon and 8 p.m.

August 29-31

DBMS-M⁴ Systems, Washington, DC. For details, contact the Continuing Education Institute, Oliver's Carriage House, 5410 Leaf Treader Way, Columbia, MD 21044, (301) 596-0111; on the West Coast, (213) 824-9545.

August 29-31

Printed Circuit Fabrication, Red Lion Inn, San Jose, CA. This technical seminar probes a variety of issues relating to printed-circuit board manufacturing. It's sponsored by PMS Industries, publisher of *Printed Circuit Fabrication* magazine. The cost for the complete program is \$300. The per day rate is \$125. Contact Mike Brody, Printed Circuit Fabrication/West Coast, Suite 105S, 4010 Moorpark Ave., San Jose, CA 95117, (408) 246-5575.

August 30

Meeting Internal Audit Objectives with Statistical Sampling—Tests of Compliance, Los Angeles, CA. Designed as an introduction to or re-

resher course in applying attribute sampling to compliance tests of internal controls, this seminar addresses the cost-effectiveness and techniques of statistical sampling. Contact Joe Bartley, Coopers & Lybrand, National Professional Education, 80 Park Plaza, Newark, NJ 07102, (201) 621-5715.

September 1983

September-October

Computer-assisted Manual Writing, various sites throughout the U.S. This one-day seminar is designed to teach attendees how to produce good software manuals. The sponsor will demonstrate a software package for automated documentation development called Manual Maker. The fee is \$195. For further information, contact Promptdoc, 833 West Colorado Ave., Colorado Springs, CO 80905, (303) 471-9875.

September-November

Computer Showcase Expos, various sites throughout the U.S. This popular show will bring together hardware and software manufacturers, dealers, and consumers of small computer systems. For details, contact The Interface Group, 160 Speen St., POB 927, Framingham, MA 01701, (800) 225-4620; in Massachusetts, (617) 879-4502.

September-November

Courses from Integrated Computer Systems, various sites throughout the U.S. Course titles include "Hands-On Pascal Workshop," "Structured Design and Programming," "Software Project Management," and "Defining Software Requirements, Specifications, and Tests." Fees range from \$695

to \$845. For information, contact Ruth Dordick, Integrated Computer Systems, 3304 Pico Blvd., POB 5339, Santa Monica, CA 90405, (213) 450-2060.

September-December

Software Workshops in MMSFORTH, Boston metropolitan area. These workshops are public versions of the professional training Miller Microcomputer Services (MMS) offers to client companies in support of the MMSFORTH product line. A variety of topics and skill levels are covered. Full details are available from Miller Microcomputer Services, 61 Lake Shore Rd., Natick, MA 01760, (617) 653-6136.

September-January 1984

Technology Opportunity Conference, various sites throughout the U.S. This conference series focuses on the convergence of optical-storage, videodisc, and computer technologies. For full details, contact Technology Opportunity Conference, POB 14817, San Francisco, CA 94114, (415) 626-1133.

September 1-2

The First Meeting of the European Chapter of the Association for Computational Linguistics, University of Pisa, Italy. A variety of formal papers will address such topics as syntax, parsing, and language generation; speech analysis and synthesis; and software tools and programming languages for computational linguistics. Contact Harold Somers, Centre for Computational Linguistics, UMIST, POB 88, Manchester M60 1QD, England.

September 6-10

Asian International Electricals, Electronics, and Communications Exhibition '83—Elecom Asia '83, Stadium Negara, Kuala Lumpur, Malaysia. This trade show serves as

a showcase for a wide spectrum of high-technology equipment and materials. Government ministers from the five ASEAN (Association of Southeast Asian Nations) countries (Indonesia, Malaysia, Philippines, Singapore, and Thailand) will attend. For details, contact Technology Marketing Analysis Corp., Suite 428, 680 Beach St., San Francisco, CA 94109, (415) 474-3000. In Malaysia, contact ISE Management (M) SDN BHD, 3-A Jalan SS 24/8, Taman Megah, Petaling Jaya, Selangor, Malaysia; tel: 749377; Telex: MA 37204 AKMISE.

September 6-10

The 1983 AAMI Regional Meeting, Detroit, MI. The Association for the Advancement of Medical Instrumentation (AAMI) has tailored this program of tutorial courses, technical service seminars, and product displays to address the regional needs of the Detroit area. Contact the AAMI, 1901 North Fort Myer Dr., Arlington, VA 22209, (703) 525-4890.

September 8-10

Personal Computer Interfacing and Scientific Instrument Automation, Greensboro, NC. For details, see August 11-13.

September 11-14

The American Data Services (ADS) Users Seminar, Marriott Resort, Lincolnshire, IL. This seminar focuses on the ADS inventory-management system. A procedural cost system for hospital departments will be introduced. Contact Sharon Spencer, American Data Services, Suite 210, 900 North Shore Dr., Lake Bluff, IL 60044, (312) 295-6850.

September 13-15

AUTOFACT Europe Conference and Exhibition, Palexpo Exhibition Center,

Geneva, Switzerland. This conference, cosponsored by the Society of Manufacturing Engineers (SME) and the Institution of Production Engineers of London, England, will focus on the technologies of automated and computer-integrated manufacturing for European production. Technical sessions will explore both theory and applications strategies. A complementary products display will be featured. Contact the Society of Manufacturing Engineers, Public Relations Department, One SME Dr., POB 930, Dearborn, MI 48121, (313) 271-0777.

September 13-15

Midcon/83 and Mini/Micro-Midwest/83, Chicago, IL. Topics on the professional program include computer simulation, energy management, laser applications, and printed-circuit-board technology. An exhibit area is planned. For further information, contact Electronic Conventions Inc., 8110 Airport Blvd., Los Angeles, CA 90045, (213) 772-2965.

September 13-15

Peripherals '83, Moscone Center, San Francisco, CA. Full details are available from Cahners Exposition Group, Cahners Plaza, 1350 East Touhy Ave., POB 5060, Des Plaines, IL 60018, (312) 299-9311.

September 14-16

Euromicro '83, Madrid, Spain. This ninth annual symposium will cover micro-processing and programming. Speeches will address economic and social aspects of microprocessors and trends in VLSI (very large-scale integration) technology. Tutorials, seminars, and an exhibition are planned. The highlight of this event is the Euromouse contest, in which mechanical mice from around the world race around a

maze. A complete program is available from Euromicro, TH Twente, POB 217, Department INF, Room A312, 7500 AE Enschede, The Netherlands; tel: (31) (53) 338799; Telex: 44200 Thes.

September 15-16

Ethernet-type Local Networks, San Francisco, CA. This is the third program in the four-part Architecture Technology Corporation 1983 Forum Series. This program will bring together manufacturers and users of local network schemes to exchange information in an informal setting. The format includes presentations, panel discussions, and a technological summary. The fee is \$395. For further information, contact the Architecture Technology Corp., POB 24344, Minneapolis, MN 55424, (612) 935-2035.

September 15-16

The Second Annual Indiana Computer Expo, Convention Center, Indianapolis, IN. This exposition is designed for business end-users interested in mini- and microcomputers, software, word processing, graphics, services, and peripherals. Contact Ernie Kerns & Associates, Trade Show Department, Suite 201, 2555 East 55th Place, Indianapolis, IN 46220, (317) 259-8111.

September 16-18

The First Annual Heart of Texas Computer Show, Convention Center, San Antonio, TX. This show will emphasize small-business systems for financial and inventory control, agribusiness, education, and personal needs. More than 200 hardware, software, and peripheral vendors will display their wares. Show details are available from Robin G. Mann, Heart of Texas, POB 12094, San Antonio, TX 78212, (512) 226-4636.

September 16-18

Great Southern Computer & Electronics Show '83, Memorial Coliseum, Jacksonville, FL. Computers, electronics, and information services will be featured. Contact Great Southern Computer & Electronics Shows, POB 655, Jacksonville, FL 32201, (904) 384-6440.

September 19-21

The Third Annual Videodisc Conference, New York Hilton Hotel, New York, NY. For details, contact Meckler Publishing, 520 Riverside Ave., Westport, CT 06880, (203) 226-6967.

September 19-23

The Ninth World Computer Congress - IFIP '83, Paris, France. This event, sponsored by the International Federation for Information Processing (IFIP), is held in conjunction with SICOB, the major French computer exposition. Formal papers and panel sessions will cover such areas as computer hardware and software, theoretical foundations of information processing, networks, and communications. For full program details, contact the U.S. Committee for IFIP '83, Dorn Computer Consultants, 25 East 86th St., New York, NY 10028, (212) 427-7460.

September 20-21

Data Storage 83, Marriott Hotel, Santa Clara, CA. This international forum covers industry issues and areas of change in data-storage equipment and applications. The fee is \$850. Contact Cartledge & Associates Inc., Suite 205, 4030 Moorpark Ave., San Jose, CA 95117, (408) 554-6644.

September 20-22

Caribbean Informatics '83, San Juan, Puerto Rico. This is the first major international exhibition and conference to be held in the Caribbean

area. For further details, contact Informatics '83, Suite 219, 3421 M St. NW, Washington, DC 20007, (703) 920-9595.

September 21-22

Business-Expo, Boston, MA. This exposition serves as a showcase for office equipment ranging from computers to coffee machines. More than 20 seminars are presented. Address inquiries to Business-Expo, 702 East Northland Towers, 15565 Northland Dr., Southfield, MI 48075, (313) 569-8280.

September 26-28

Maecon/83, Kansas City, MO. This electronic show and convention explores such topics as aerospace electronics, computer peripherals, laser technology, and personal computing. Contact Electronic Conventions Inc., 8110 Airport Blvd., Los Angeles, CA 90045, (213) 772-2965.

September 26-29

The World of CAD/CAM, Boca Raton Resort Hotel, FL. This seminar provides an overview of how manufacturing will change as the automated factory becomes a reality. It will consist of four one-day presentations in computer-aided engineering, design, manufacturing, and computer-integrated manufacturing. For a brochure, write or call the Center for Manufacturing Technology, 4170 Crossgate Dr., Cincinnati, OH 45236, (513) 791-8801.

September 26-30

Comcon Fall '83, Marriott Crystal Gateway Hotel, Arlington, VA. The theme of this show is "Delivering Computer Power to End Users." It features technical papers and panel sessions that address a variety of computer and computer-network issues. It is sponsored by the

Institute of Electrical and Electronics Engineers (IEEE) Computer Society. For more information, contact Comcon Fall '83, POB 639, Silver Spring, MD 20901, (301) 589-8142.

September 26-30

Conference on Networks and Electronic Office Systems, University of Reading, Berkshire, England. This conference will provide a forum for the exchange of information and for discussion of recent and future developments relating to networks and electronic office systems. Further information is available from the Conference Secretariat, Institution of Electronic and Radio Engineers, 99 Gower St., London WC1E 6AZ, England; tel: 01-388 3071; Telex: Instrad London WC1.

September 26-30

Expo Beirut '83, Beirut, Lebanon. This is Lebanon's first international reconstruction/development exposition and conference after eight years of civil war. Topics to be covered include construction, transportation, communications, agriculture, computer hardware and software, metallurgy, textiles, and automated equipment. Further details are available from Show-Tech International Inc., 950 Third Ave., New York, NY 10022.

September 28-29

Ottawa Computer and Office Automation Show, Civic Centre, Ottawa, Ontario, Canada. For details, contact Industrial Trade Shows of Canada, 20 Butterick Rd., Toronto, Ontario M8W 3Z8, Canada, (416) 252-7791.

September 28-October 2

The Sixth Personal Computer World Show, Barbican Centre, London, England. This show, one of the largest computer shows in Great Britain, is sponsored by *Personal*

Computer World magazine. Business, scientific, technical, and educational uses of microcomputing will be featured as well as hobbyist and home-based systems. For information, contact Tim Collins, Montbuild Ltd., 11 Manchester Square, London W1M 5AB, England; tel: 01-486 1951; Telex: 24591.

September 29-October 1

CP/M '83 East, Hynes Auditorium, Boston, MA. For information on this conference and exposition, contact Northeast Expositions Inc., 826 Boylston St., Chestnut Hill, MA 02167, (800) 343-2222; in Massachusetts, (617) 739-2000.

October 1983

October 1

The Third Annual Microcomputers in Education Conference, Dutchess County Community College, Poughkeepsie, NY. Dr. Delores Shanahan, an innovator in the field of special education and computers, will speak at this event sponsored by the Microcomputer Educator Group. Details are available from Dr. Florence Staats, Office of Community Services, Dutchess County Community College, Pendell Rd., Poughkeepsie, NY 12601, (914) 471-4500, ext. 240.

October 2-5

Computer Systems Exposition, MGM Grand Hotel, Las Vegas, NV. This exposition will be held in conjunction with the annual meeting of the National Association of Convenience Stores. Hardware and software will be displayed, and computer consultants will be on hand to answer questions. For details, contact the National Association of Convenience Stores, Suite 809, 5201 Leesburg

Pike, Falls Church, VA 22041, (703) 578-1800.

October 2-6

The Annual Meeting of the American Society for Information Science-ASIS-83, Crystal City Hyatt Regency, Arlington, VA. The theme for this meeting is "Productivity in the Information Age." Papers, special-interest sessions, information briefings, an information-science theater, and demonstrations will be featured. Further information is available from Edmond Sawyer, ASIS Headquarters, 1010 Sixteenth St. NW, Washington, DC 20036, (202) 659-3644.

October 4-6

The Southwest Computer Conference, Tulsa, OK. The theme for this conference is "Managing Information Technology in the 80s." Computer hardware and software will be exhibited. Contact the Southwest Computer Conference, POB 950, Norman, OK 73070, (405) 329-3660.

October 6-11

Japan Electronics Show '83, Osaka International Trade Fair Grounds, Osaka, Japan. This show will cover a range of consumer and industrial electronic products and components. For information, contact the Japan Electronics Show Association, 24 Mori Building 11F, 3-23-5, Nishi-Shinbashi, Minato-ku, Tokyo 105, Japan; tel: (03) 433-7751.

October 7-9

Great Southern Computer & Electronics Show '83, Centroplex Expo, Orlando, FL. For details, see September 16-18.

October 8-10

PC '83, Bayside Exposition Center, Boston, MA. This conference and exposition features IBM Personal Computers and compatible equipment. A seminar program

will explore IBM PC applications, provide technical information, and offer general sessions designed to show users how to get the most from their IBM. For details, contact Northeast Expositions, 822 Boylston St., Chestnut Hill, MA 02167, (800) 841-7000; in Massachusetts, (617) 739-2000.

October 10-14

Defense Computers-Graphics-DCG '83, Convention Center, Washington, DC. Sessions and tutorials will complement this conference and exposition. For more information, contact DCG '83, Suite 333, 2033 M St. NW, Washington, DC 20036, (202) 775-9556.

October 11-13

Southwest Semiconductor & Electronics Exposition-SSE'83, Civic Plaza Convention Center, Phoenix, AZ. Approximately 200 suppliers of equipment, materials, and services used in the electronics industry will attend this show. A technical conference will be held. Contact Carlidge & Associates Inc., Suite 205, 4030 Moorpark Ave., San Jose, CA 95117, (408) 554-6644.

October 12-21

The Sixth International Trade Exhibition on Office Organizational Systems, Office Furniture, and Office Aids - Systemotechnika '83, Vassilievsky Ostrov Exhibition Centre, Leningrad, Union of Soviet Socialist Republics. On display will be communications systems, microfilming equipment and systems, data-processing equipment, and computers. Contact Düsseldorf Messgesellschaft mbH-NOWEA-Central Division - Foreign Fairs, Düsseldorf Exhibition Centre, 4000 Düsseldorf 30, Federal Republic of Germany; tel: (02 11) 45 60-1.

October 13-15

Edutech/East '83, Civic Center, Philadelphia, PA. Formerly called Ed Com, this conference and exposition is designed for educators at all levels. Presentations will address such topics as computer-aided instruction, administrative uses of computers, classroom management, programming, research applications, authoring languages, and literacy. The format includes workshops, seminars, demonstrations, hands-on sessions, discussions, and micro courses. Hardware, software, and publishing companies will exhibit their wares. Contact Carol Houts, Judco Computer Expos Inc., Suite 201, 2629 North Scottsdale Rd., Scottsdale, AZ 85257, (800) 528-2355; in Arizona, (602) 990-1715.

October 14-15

Computers and Reading/Learning Difficulties, Dallas, TX. Workshops, hands-on exhibits, and speakers will explore such topics as using computers in learning disability classrooms and evaluating software. This program is designed for all education levels. For information, contact Frost Conference Management, Department I, 1070 Crows Nest Way, Richmond, CA 94803, (415) 222-1249.

October 14-15

The Fifth Annual FORTH Convention, Hyatt Hotel, Palo Alto, CA. Hands-on tutorials, exhibits, lectures, and discussions highlight this event. The theme is "FORTH-based Systems - A Look Into the Future." Registration is \$5. Full details are available from the FORTH Interest Group, POB 1105, San Carlos, CA 94070, (415) 962-8653.

October 14-16

The UCSD Pascal System Users Society Fall Meeting,

Hyatt Regency Crystal City, Washington, DC. Contact the Secretary, USUS, POB 1148, La Jolla, CA 92038.

October 15

NJ-NY-CT Microcomputer Show and Flea Market, Meadowlands Hilton Hotel, New Jersey Sports Complex, East Rutherford, NJ. More than 75 commercial exhibitors and 200 flea-market booths will feature hardware, software, books, magazines, and accessories for all popular computers ranging from Apple to Zenith. Registration is \$5 for adults and \$2 for children. Contact the Kengore Corp., POB 13, Franklin Park, NJ 08823, (201) 297-2526.

October 16-18

The Fifth Annual Hong Kong Consumer Electronics Show, New World Hotel and Regent Hotel, Hong Kong. For details, contact IBS Trade Fair Ltd., 17th Floor, Tung Sun Commercial Centre, 200 Lockhart Rd., Hong Kong; tel: 5-732388-9; Telex: 63037 HKIBS HX.

October 17-19

The Eighth Conference on Local Computer Networks, Minneapolis, MN. The theme for this conference is "Practical Applications and Issues in Local Computer Networks." Papers and tutorials will address such issues as users' versus manufacturers' needs, public versus private networks, software, and VLSI (very large-scale integration). Contact the IEEE Computer Society, POB 639, Silver Spring, MD 20901.

October 18-20

The Fourteenth Annual International Test Conference, Franklin Plaza Hotel, Philadelphia, PA. For information, contact the Conference Registrar, POB 371, Cedar Knolls, NJ 07927, (201) 267-7120.

October 18-21

The Third Symposium on Microcomputer and Microprocessor Applications- μ P '83, Hotel Duna Intercontinental and the Hungarian Academy of Sciences, Budapest, Hungary. The conference language will be English. Full details are available from Mrs. I. Bába, Scientific Society for Telecommunication, POB 451, H-1372 Budapest, Hungary; tel: (36) 1 113-027; Telex: MTE SZ 22-5792.

October 19-20

Calgary Computer & Office Automation Show and Conference, Roundup Centre, Calgary, Alberta, Canada. For details, contact Industrial Trade Shows of Canada, 20 Butterick Rd., Toronto, Ontario M8W 3Z8, Canada, (416) 252-7791.

October 19-21

The Fourth Canadian Symposium on Instructional Technology, Westin Hotel, Winnipeg, Manitoba, Canada. This symposium, designed for education and training professionals and those interested in computer-aided learning, will explore the theme "Computer Technologies for Productive Learning." Topics on the agenda include computer awareness and literacy in schools and society, systems technology, and computer-aided training and retraining for business, industry, and government. A products exhibition will be held. Contact Ken Charbonneau, Conference Services Office, National Research Council of Canada, Ottawa, Ontario K1A 0R6, Canada, (613) 993-9009; Telex: 053-3145.

October 19-21

IDATE-The Fifth International Conference, Montpellier, France. The theme for this conference, sponsored by the International Telecom-

munication Union, is "Picture Networks." Topics of interest include network functioning and areas of applications, economics and law relating to the visual media, network languages, and languages on the networks. The conference language is French. For further details, contact Francois Rabaté, Responsable Scientifique, Journées Internationales 1983, IDATE—Bureaux du Polygone, 34000 Montpellier, France; tel: (33-67) 65 48 48; Telex: IDATE 490 290.

October 19-21
The National Software Show, Trade Show Center, San Francisco, CA. Full details are available from Ragging Bear Productions Inc., Suite 175, 21 Tamal Vista Dr., Corte Madera, CA 94925, (800) 732-2300; in California, (415) 924-1194.

October 19-21
SIBEC—Info Expo, Palais des Congres, Montreal, Canada. Exhibits related to the computer and office automation industries will be held. An international line-up of speakers has been invited. Contact Informatique Québec (Info Expo) Ltée, 1057 Avenue Laurier Ouest, Outremont, Québec H2V 2L2, Canada, (514) 270-5481; in the Toronto area, call (416) 281-3459.

October 19-22
Percompasia 83—The Second South East Asian Personal Computer Hardware & Software Show & Conference, World Trade Centre, Singapore, Republic of Singapore. This show is devoted to all aspects of personal computing. Further details are available from Overseas Exhibition Services Ltd., 11 Manchester Square, London W1M 5AB, England; tel: 01 486 1951; Telex: 24591.

October 24-26
The Annual Conference of the Association for Computing Machinery—ACM '83, Sheraton Centre Hotel, New York, NY. Exhibits of computer hardware and software and paper sessions will focus on the conference theme, "Extending the Human Resource." The emphasis will be on theory and practices of personal computing. Highlighting the conference will be the the Fourth International Computer Chess Championships. For details, contact Thomas A. D'Auria, Assistant Commissioner, City of New York, Computer Service Center, 11th Floor, 111 8th Ave., New York, NY 10011, (212) 620-5055.

October 25-27
The Andean Informatics '83, Bogota, Colombia, South America. This is the first major international exhibition and conference to be held in the Andean region. For details, contact Informatics '83, Suite 219, 3421 M St. NW, Washington, DC 20007, (703) 920-9595.

October 25-28
Working Conference on Prototyping, Brussels, Belgium. This conference will focus on the user-oriented development of information systems supported by prototyping. Research and technical papers will be presented. The sponsor is the Commission of the European Communities. For information, contact Reinhard Budde or Heinz Zuellighoven, GMD-IST Postfach 1240, Schloss Birlinghoven, D-5205, St. Augustin 1, West Germany; tel: 02241/14-2440; Telex: 8 89 469 gmd d.

October 26-28
Developing Long-Range Systems Strategies, Sheraton Hotel, Washington, DC. This is part of the George Washington University Systems

General Software, Inc. Authorized CompuPro System Center

HARDWARE	PL/I-80	\$410	REDDING GROUP ... CALL	
COMPUPRO SYSTEMS	Pascal MT +	\$410	SORCIM	
System 8/16-A	Compiler	\$315	Pascal/M Z80	\$349
System 8/16-B	SPP Only	\$160	Pascal/M 86/88	\$449
System 8/16-C	8" Only		Act 65, 68, 69, 86, 88	\$140
COMPUPRO BOARDS	RMAC, Linklib, XREF	\$178	Tran 86	\$110
Ram 16-64	Display Manager	\$345	Supercalc	\$200
Ram 17-64	Access Manager	\$250	Supercalc II	\$210
Ram 21-128			STRUCT. SYS. GROUP	
M Drive/H			GL, AR, AP, PR, OE	\$790
CPU Z			SUPERSOFT	
CPU 8085/88			Diagnostic II	\$ 84
CPU 286			Forth	\$149
Freedom Liberty			SSS Fortran	\$255
100 Terminal			Fortran w/RATFOR	\$310
PRINTERS			C Compiler	\$200
Okidata 92A			Tiny Pascal	\$ 80
Okidata 93A			Disk Doctor	\$ 84
Prowriter 1			ADA	\$220
Prowriter 2			Term II	\$169
SOFTWARE			Scratch Pad	\$220
ARTIFICIAL INTELLIGENCE			Dataview	\$150
Dental (PAS-3)			Stats Graph	\$150
Medical (PAS-3)			Nemsis	\$ 40
Programmable			Dungeon Master	\$ 40
ASHTON-TATE			AnaLiza II	\$ 40
dBASE			Data View-Stats-	
Financial Planner			Scratch Pkg.	\$465
The Strategist			IBM PC	
CONDOR			Supercalc	\$220
DIGITAL RESEARCH			Visicalc (256K)	\$220
CP/M			Optimizer	\$200
2.2 Intel MDS-800		\$145	Supersoft C-CP/M86	\$400
Northstar (Horizon)		\$145	Supersoft C-CP/M86	\$255
Micropolis		\$169	DOS	\$255
TRS Model II		\$159	Concurrent CPM 86	\$100
TRS Model 12/16		\$185	RM Cobol	\$790
CB-80		\$410	Volkswriter	\$145
CBasic II		\$114	Lotus 1-2-3	CALL

Mailing Address: 1454 S. 25th St., Terre Haute, IN 47803. WE HONOR VISA and MASTERCHARGE. TOLL FREE—Outside Indiana. ORDER DESKS ONLY 1-800-457-0517. For Information or Questions (812) 234-9421. Call our Information number about our complete Software & Hardware Line. Not to be confused with Software General. Add \$3.50 postage and handling per each item. Indiana residents add 5% sales tax. Allow 2 weeks on checks. COD add \$3.00 per item. Prices subject to change without notice. All items subject to availability. This is only a partial listing of our hardware and software. Call us today and save.

PRINTER RIBBONS DISCOUNTED

BLACK NYLON	PRICE EACH	QUANTITY
C. Itoh Prowriter	7.10	_____
Diablo Hytype I	7.15	_____
Diablo Hytype II	5.60	_____
Diablo Hytype II Matrix	10.85	_____
Epson MX 70/80	6.00	_____
IBM Silver Dollor Cartridge Beehive	6.35	_____
NEC Spinwriter	6.35	_____
Qume I (Square Corner)	4.65	_____
Radio Shack LP 3 (4&5)	7.00	_____
Radio Shack LP 6	6.45	_____
Tritel	9.55	_____
Wang-5	7.00	_____
Digital LA 34	7.00	_____
Black M/S		
Diablo Hytype I	5.50	_____
Diablo Hytype II	5.65	_____
IBM Correctable, High Yield	2.25	_____
Lift off Tape (IBM Type)	.65	_____
NEC Spinwriter	6.45	_____
Olivetti ET 201/202 Correctable	6.35	_____
Qume (6240) Std. Vid.	3.50	_____
Qume (6240) Hi. Vid.	4.20	_____
Qume I (Square Corner)	4.00	_____
Qume IV	6.35	_____
Richo	6.40	_____
Wang-5	5.05	_____
Xerox 850/860	5.90	_____

We also have Brown, Red, Blue & Green colors at 20 per cent additional. Prices included delivery in continental U.S.

Check/MO _____ MasterCharge _____ Visa _____

Card # _____ Expiration Date _____

Signature _____

Name (please print) _____

Address _____

City _____ State _____ Zip _____

Mail order to: Printer Ribbon Supply Co.
P.O. Box 920145
Norcross GA 30092
(404) 446-1547

GA residents add 3% sales tax

CLIP AND MAIL

Executive Forum series. Contact the Conference Manager, U.S. Professional Development Institute, 1805 Powder Mill Dr., Silver Spring, MD 20903, (301) 445-4400.

October 28-30

Applefest, Moscone Center, San Francisco, CA. More than 300 displays and booths of Apple computer equipment and accessories will be featured. Seminars, panel discussions, conferences, and workshops will be held. Additional information is available from Northeast Expositions Inc., 822 Boylston St., Chestnut Hill, MA 02167, (800) 343-2222; in Massachusetts, (617) 739-2000.

October 30-November 2

DPMA Baltimore '83, Convention Center and Hyatt Regency Hotel, Baltimore, MD.

The theme for this conference, sponsored by the Data Processing Management Association (DPMA), is "Information on the Firing Line." Seminars, workshops, general sessions, and product displays will be featured. Contact Jim Osowski, DPMA International Headquarters, 505 Busse Highway, Park Ridge, IL 60068, (312) 825-8124.

October 31-November 2

The Ninth International Conference on Very Large Databases, Palazzo dei Congressi, Florence, Italy. This conference seeks to identify and encourage the research, development, and applications of database technology. Subjects of interest include database control, modeling and managing unformatted data, and novel environments and

applications of database technology. Contact Mario Schkolnick, K 55-281, IBM Research Labs, 5600 Cottle Rd., San Jose, CA 95193, (408) 256-1648. In Italy, Renzo Pinzani, Istituto di Matematica U. Dini, Viale Morgagni, 67/A, 50134 Florence, Italy.

October 31-November 3

International Conference on Computer Design-VLSI in Computers, Rye Town Hilton, Port Chester, NY. This conference will cover the VLSI (very large-scale integration) aspects of the interaction between fabricators and system designers in hardware, software, and reliability in computers. Contact the IEEE Computer Society, POB 639, Silver Spring, MD 20901. ■

BYTE's Bits

Trade List Available

A trade list of nearly 2000 overseas buyers, agents, and distributors of computers and peripherals is available from the Department of Commerce. The list provides company names, addresses, contacts, telephone and Telex numbers, and five-digit SIC (Standard Industrial Classification) codes for potential customers in more than 130 countries. For a copy, send \$12 to the U.S. Department of Commerce, Office of Trade Information Services, Room 1320, Washington, DC 20230. Checks should be payable to U.S. Department of Commerce/TL. ■

Microrubble

How long could your business survive if your computer were suddenly reduced to a smoldering pile of microrubble? If it were stolen? Or tampered with?

For as little as \$35/yr SAFEWARE provides for full replacement of all hardware, media and purchased software after a low \$50 deductible.

You're covered against fire, theft, accidental damage, earthquakes, and damage in transit. SAFEWARE even covers power surges, the second leading destroyer of microsystems. And, in the event of a claim, you'll get fast replacement. So you can be back in business almost before the smoke clears.

To find out more, or to obtain immediate coverage, call the toll free number. Or write: Columbia National General Agency, 88 E. Broad Street, Columbus, OH 43215.

1-800-848-3469

(In Ohio call toll free 1-800-848-2112)

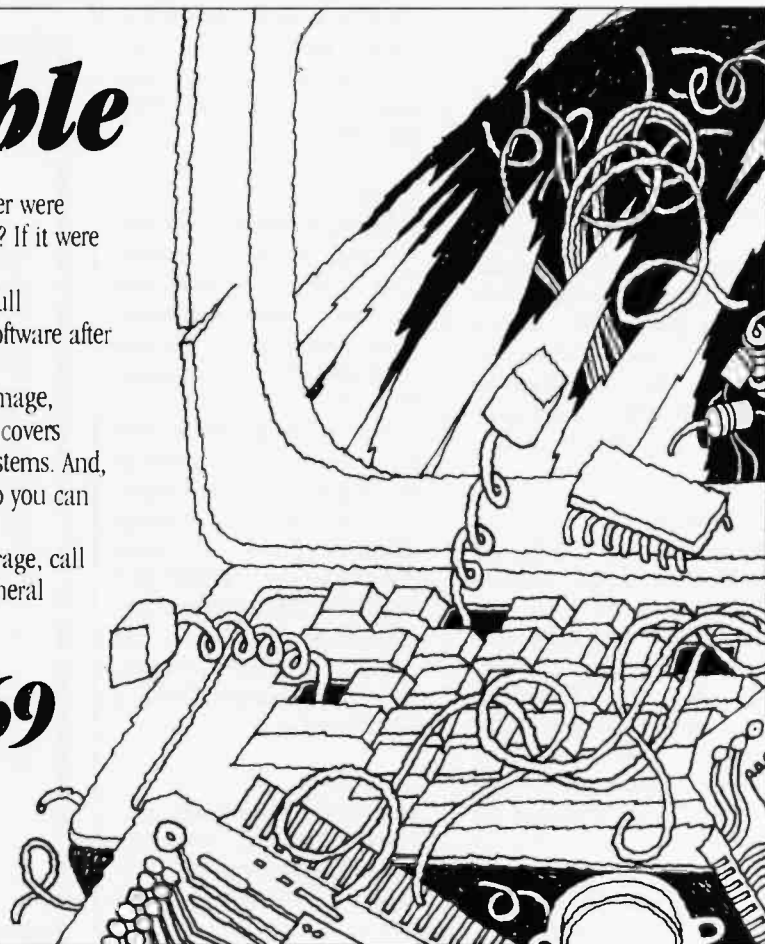
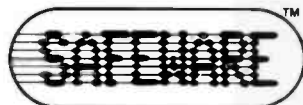

What's New?

C-RELATED PRODUCTS



C for CP/M-80, CP/M-86, and MS-DOS

Supersoft has released a version of its Supersoft C compiler for CP/M-80, CP/M-86, and MS-DOS operating systems. This release is syntactically compatible with Unix Version 7 C and supports such features as long-integer and double floating-point functions. Supersoft C is a multipass compiler that is said to produce highly optimized code. Many Unix-compatible functions are included, which permits transporting source programs between Unix C and Supersoft C with few changes.

An extensive list of library functions is provided with the source code. The Supersoft C compiler costs \$500; the CP/M-80 version is \$275.

For full details, contact Supersoft, 1713 South Neil St., POB 1628, Champaign, IL 61820, (217) 359-2112.

Circle 600 on inquiry card.

Optimizing C Compiler

The Optimizing C86 compiler is designed for professional programmers working with PC-DOS, MS-DOS, or CP/M-86. It permits addressing of 1024K bytes of RAM and provides the option to emit either assembly-language or object-code formats of Microsoft. Optimizing C86 costs \$395. A \$10 evaluation kit is avail-

able. Contact Computer Innovations Inc., Suite J-30X, 10 Mechanic St., Redbank, NJ 07701, (201) 530-0995.

Circle 601 on inquiry card.

C Executive Version 1.3

Version 1.3 of the C Executive has been released by JMI Software. The C Executive allows multiple C and Pascal tasks to run concurrently with inter-task communication, resource coordination, and formatted I/O. The monitor can be stored in ROM. The real-time preemptive scheduler is sensitive to both task priority and system events. Multiple user terminals can be supported with Unix-like characteristics. Other features include clock support, time-based task scheduling, and a portable library of more than 50 routines for memory management, character-string manipulation, and I/O. The complete standard Unix C library is supported as are most standard Pascal procedures and functions.

The C Executive works with a variety of microprocessors, including Intel's 8080/8085 and 8086/8088, the Zilog Z80, Motorola's MC68000 and 6809, and the National Semiconductor NS16032. In binary and source form, the C Executive costs \$300. Contact JMI Software Consultants Inc., 1422 Easton Rd., Roslyn, PA 19001, (215) 657-5660.

Circle 602 on inquiry card.

C Programming Guide

The C Programming Guide by Dr. Jack Purdum is a comprehensive tutorial on the fundamentals of the C programming language. Written in an easy-to-understand style, this book offers users at all levels of expertise a learning guide to C. Appendices provide lists of moderately priced commercial C compilers and a summary of the C language's syntax. Example programs and illustrations are included in the presentation.

This 250-page guide costs \$17.95 and is available from Que Corp., 7960 Castleway Dr., Indianapolis, IN 46250, (317) 842-7162.

Circle 603 on inquiry card.

PUBLICATIONS

Computer Glossary for Managers

Alan Freedman, an expert in the field of computer literacy, has created a resource work for nontechnical business managers. The Computer Glossary is an illustrated guide through microcomputer jargon. It covers all aspects of computing in a straightforward, plain-talking presentation. Individual copies of the glossary cost \$14.95 and are available from Prentice-Hall (POB 500, Englewood Cliffs, NJ 07632). In lots of 10 to 99, each copy costs \$12.95. Order in bulk from The Computer Language Co. Inc., 140 West 30th St., New York, NY 10001.

What's New?

Children's Workshop Enters Computer Publishing

The Children's Television Workshop will launch a monthly magazine for children on computers and electronic technology this fall. Enter will focus on career opportunities and issues relating to the growth of computer technology in the 1980s. Articles on new developments in computer technology and the influence of computers on a wide range of professions, games, quizzes, puzzles, and simple programming challenges will be among this magazine's monthly features.

Annual subscriptions will cost \$12.95 (10 issues). A classroom bulk rate will be offered. Contact the Children's Television Workshop, One Lincoln Plaza, New York, NY 10023, (212) 595-3456. Circle 604 on inquiry card.

Information Technology Update

Information Technology On Screen: New Approaches in Viewdata, Teletext and Cable is an update of some of the more important developments taking place or being planned in information technology. This book is a compilation of essays presented at the November 8, 1982 Information Technology On Screen seminar. It's available for \$12 from the Oryx Press, 2214 North Central, Phoenix, AZ 85004. Circle 605 on inquiry card.

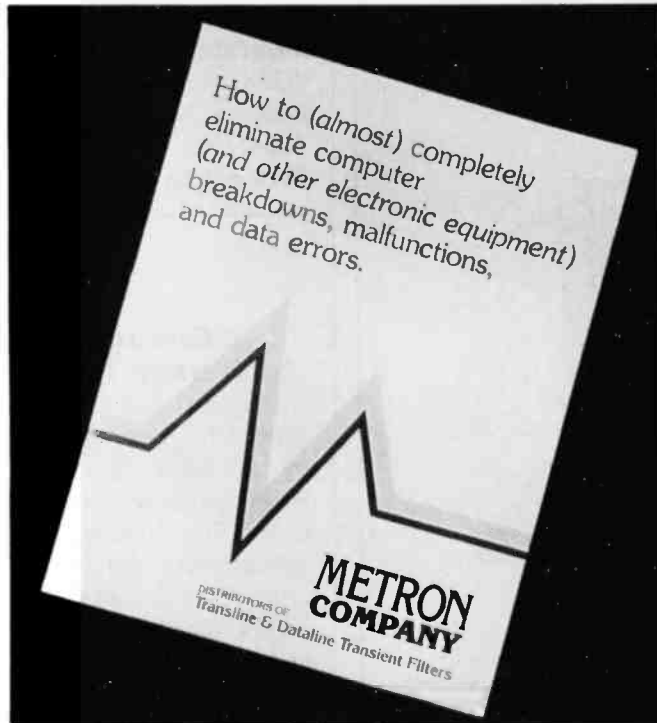

How to Stop Computer Problems

The introduction of a booklet entitled *How to (Almost) Completely Eliminate Computer Breakdowns and Malfunctions* was announced by the Metron Company. This booklet discusses the most common causes of computer failures and errors. Possible solutions are of-

fered. Also provided are case histories of successful treatments.

The booklet is available free of charge from the Metron Co., Suite 216, 1250 West Dorothy Lane, Kettering, OH 45409, (513) 298-0964. Circle 606 on inquiry card.

Newsletter for Physicians

A medical newsletter, the *Physician Computer Monthly*, provides information to doctors using microcomputers in their practices. This independent journal covers applications for practice management, patient care, continuing medical education, and communications. It's written in non-technical language, and it provides hardware up-

dates, software reviews, and news on medical networks.

A one-year subscription is \$95. A free sample issue will be provided upon receipt of a request made on letterhead. For full details, write to American Health Consultants, 67 Peachtree Park Dr., Atlanta, GA 30309. Circle 607 on inquiry card.

Tips on Caring for Printers

The Care & Feeding of Line Printers is a free 8-page booklet from Digital Associates Corporation. Designed to help you maximize your printer's performance, longevity, and cost-effectiveness, this booklet offers hints and little-known facts on duty-cycle, site environment, static, and printer service and maintenance. Thirteen major aspects of line printer operation are covered, and special tips on how to make a printer last longer are presented.

To get your free copy, write to the Manager/Marketing Communications, Digital Associates Corp., 1039 East Main St., Stamford, CT 06902, or call (203) 327-9210. Circle 608 on inquiry card.

Consumer Buying Guide

Designed to help consumers make an informed decision, *How to Buy a Home Computer* was written by Wes Thomas for the Consumer Electronics Group of the Electronic Industries Association. This 50-page illustrated book provides 11 step-by-step practical questions that embrace a variety of buying considerations. Fill-in-the-blank questions that the consumer should ask about software packages and computers are provided. A budget form for planning expenditures is also included.

What's New?

Retailers can order copies of *How to Buy a Home Computer* at quantity prices beginning at less than \$0.25 each. Consumers can obtain a free copy by sending a 5- by 7-inch, self-addressed envelope with \$0.54 postage to the Electronic Industries Association, Consumer Electronics Group, POB 19100, Washington, DC 20036, (202) 457-4919.

Circle 609 on inquiry card.

Computer Selection Guide for Managers

A guide for department-level professionals and management information service managers has been produced by Datapro Research Corporation. *How to Select Microcomputers for the Corporate Environment* explains in detail the factors to be considered for properly evaluating desktop computers in the corporate environment, including equipment requirements, software, and support services. This guide addresses key questions involved in selecting a microcomputer, such as policy formulation, vendor evaluation, and software selection. Reports cover the marketplace for computer equipment and software, economic analysis, data security and reliability, training, consulting, installation, and technology. A 10-page "Microcomputer Acquisition Checklist" that aids the user in ensuring that no major selection

concerns are overlooked is also included.

How to Select Microcomputers for the Corporate Environment costs \$19 per copy. It's available from Datapro Research Corp., 1805 Underwood Blvd., Delran, NJ 08075, (800) 257-9406; in New Jersey, (609) 764-0100.

Circle 610 on inquiry card.

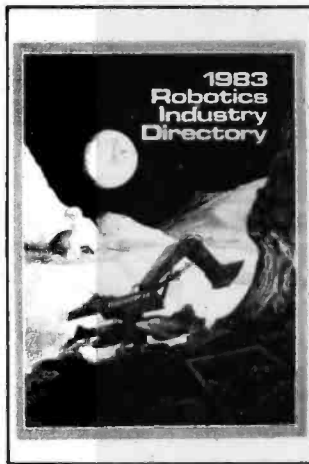

Annual Robotics Directory Released

Technical Database Corporation has released its 1983 Robotics Industry Directory. This 348-page directory covers industrial robot models and components with an emphasis on specification information. It features 213 listings that contain specifications on accuracy, velocity, number of axes, load-carrying capacity, robot weight, floor space required, and type of control system. Also included are applications and sensors supported, price range, and number of systems installed. Side-by-side evaluations of competitive models and indexes of products and vendors complete this directory.

The 1983 Robotics In-

dustry Directory costs \$35. Outside the U.S., it's \$43. Bimonthly specification updates are \$15 (\$19 foreign). Contact Technical Database Corp., POB 720, Conroe, TX 77305, (409) 539-9688.

Circle 611 on inquiry card.

Yellow Pages Cover Intel Support

The Intel Yellow Pages lists more than 2000 products and services that support Intel architectures. The listings are organized under 10 categories, including communications, databases, technical and consulting services, and utilities. Under the main headings are a number of subheads. An alphabetical listing with brief descriptions of the more than 250 companies participating in the book and geographical and corporate/product cross-indices are provided.

The Intel Yellow Pages are free with a letterhead request. For full details, contact Intel Corp., Literature Department, 3065 Bowers Ave., Santa Clara, CA 95051.

Circle 612 on inquiry card.

Computer Gazette Aimed at Students

Computer Science Press has introduced the *Bits 'n Bytes Gazette*, a set of 10 mini newspapers about computers for elementary and junior high school students. Suitable for use as a classroom handout, the *Gazette* has articles and

games that educate and entertain. It discusses business, medical, personal, and community uses of computers and highlights career opportunities. A guide with in-depth explanations and suggested activities is provided for instructors and parents.

The *Bits 'n Bytes Gazette*, by Rachele Heller and C. Dianne Martin, costs \$10 per set. School discounts ranging from \$3 to \$7.50 per set are available. Contact the Computer Science Press Inc., 11 Taft Court, Rockville, MD 20850, (301) 251-9050.

Circle 613 on inquiry card.

SOFTWARE

FORTH for IBM PC

Next Generation Systems has introduced a version of the FORTH programming language for the IBM Personal Computer. This package is based on the FORTH-79 Standard, and a FORTH Interest Group (fig) lookalike mode is provided. NGS FORTH uses the DOS file system, which lets you read from or write to programs and data in DOS files. Other features include an auto load screen boot, three debugging aids, and individual code, stack, and data blocks as large as 64K bytes.

NGS FORTH comes with an indexed, 200-page manual. It costs \$66, plus \$2 shipping. Contact Next Generation Systems, POB 2987, Santa Clara, CA 95055.

Circle 614 on inquiry card.

What's New?



Financial Facts

Financial Facts performs a variety of financial functions, including depreciation, interest, loan principal, and future value. It offers four methods of calculating depreciation and amortization tables for mortgage payments and other long-term loans. It gives you the ability to compute the future value of investments, the value of an investment after a deposit or withdrawal, and

nominal and effective interest rates.

Financial Facts runs on Apple II, II Plus, or IIe computers with one disk drive and 48K bytes of memory and on 64K-byte IBM Personal Computers with PC-DOS and a disk drive. It costs \$59.95 and is available from Howard W. Sams & Co., 4300 West 62nd St., Indianapolis, IN 46268, (317) 298-5400.

Circle 615 on inquiry card.

Interactive Authoring System

The McGraw-Hill Interactive Authoring System helps you create computer-aided instruction courses on an IBM Personal Computer. Previous programming knowledge is not required because step-by-step onscreen directions guide you through the writing process. Your lessons can have multiple choice, matching, and fill-in-the-blank questions coupled with text, color graphics, and videotape segments. Sixteen foreground and eight background colors for graphics

and text are available. The system's interactive video capabilities are compatible with many video players with remote control circuitry.

The Interactive Authoring System requires 128K bytes of memory, two 320K-byte floppy-disk drives, and color and asynchronous communications cards. For details, contact McGraw-Hill Interactive Authoring System, 26th Floor, 1221 Avenue of the Americas, New York, NY 10020, (212) 997-6458.

Circle 616 on inquiry card.

Dynacomp Enters Heath/Zenith Software Market

Dynacomp now offers 47 software packages for Heath/Zenith computer users. Applications available include engineering, statistics, education, personal finance, business, and games. For a free 64-page software catalog, write to Dynacomp Inc., Department C4, 1427 Monroe Ave., Rochester, NY 14618, or call (716) 442-8960.

Circle 617 on inquiry card.

Compaq Number Cruncher

Pyramid Data Ltd. has released the Number Cruncher, a financial-modeling system for the Compaq portable computer. This program blends text editing and calculating capabilities into a flexible modeling program. Fixed rows and columns are not used by the Number Cruncher, which permits user-defined report formats. Standard row and column mathematics functions are provided, as are commands that let you add, subtract, multiply, and divide blocks of rows and columns to produce a single total.

The Number Cruncher, which requires 128K bytes of memory, costs \$395. Complete details are available from Pyramid Data Ltd., POB 10116, Santa Ana, CA 92711, (800) 521-2233; in California, (714) 639-1527.

Circle 618 on inquiry card.

Accountant for TI Professional Computer

Continental Software has reconfigured The Home Accountant for the 128K-byte Texas Instruments Professional Computer. This menu-driven program can maintain 200 budget categories, track five checking accounts, reconcile bank statements, record transactions, and handle 2000 transactions per month. It offers a forecasting module, graphic capabilities, and one-key English-language commands. The Home Accountant's printout function, which can be used for writing checks or organizing data for readouts, works with most dot-matrix and daisy-wheel printers.

The Home Accountant runs on MS-DOS using MS-BASIC. The suggested price is \$150. Contact Continental Software, 11223 South Hindry Ave., Los Angeles, CA 90045, (213) 417-8031.

Circle 619 on inquiry card.

Moon Hopper Features Graphics, Sound, and Colors

Moon Hopper from Computerware is an arcade-type game for the Radio Shack TRS-80 Color Computer and the TDP-100. While on test maneuvers of the new Moon Hopper space exploration vehicle, you are attacked by a swarm of aliens. To reach the next moon base, you must hop and roll over craters and rocks while

What's New?

COMMUNICATIONS

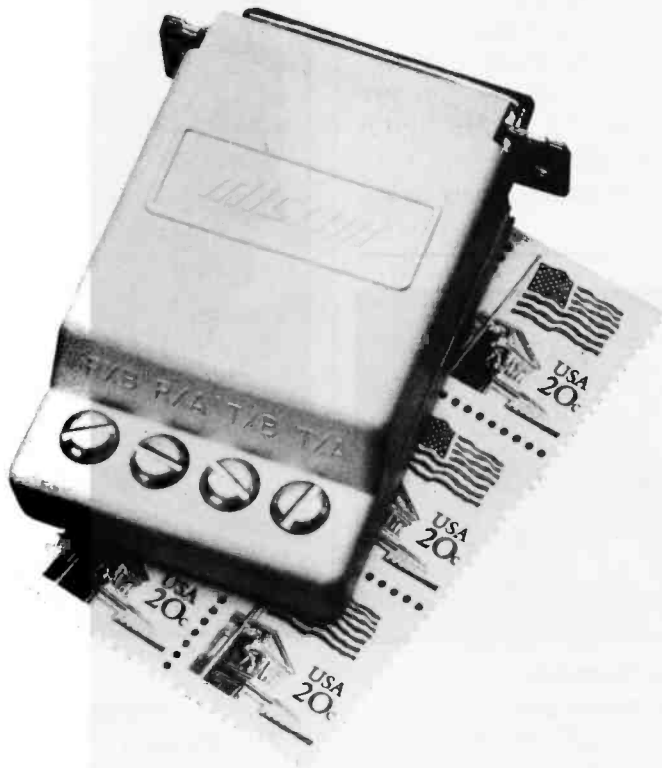

Compact Datasets

Micom's Micro400 Local Dataset Models 430 and 431 connect terminals and computers in a local environment. Intended for use on a college campus or within a building, these devices provide full-duplex asynchronous communications for up to 3 miles at 9600 bps (bits per second). The Model 430 can cover more than 1 mile at 19,200 bps. They plug directly into an RS-232C interface and are powered by the host system. Both models are about the size of a package of cigarettes.

The Model 430 Line Driver is designed for use on customer lines. It costs \$85. The Model 431 Local Dataset is intended for operation on telephone company-supplied limited-

distance private circuits. It's available for \$95. For further details, contact Micom Systems Inc., 20151 Nordhoff St., Chatsworth, CA 91311, (213) 998-8844. Circle 622 on inquiry card.

Software, Hard-Disk Create Network

Link-Bos is an integrated hardware and software approach to networking. It provides the ability to link multiple users, computers, operating systems, and selected applications programs through a hard-disk unit. Link-Bos software allows sharing of data with a mix or a match of such 8-, 16-, or 32-bit computers as Radio Shack, Victor, and Zenith. When running any

one of the more than 50 Bos applications programs, all computers in the network can simultaneously use the same data. Each single-user operating system and software will work unchanged.

Link-Bos parallels the operating system supplied with your system. All computers in the network are connected to a common Winchester hard-disk unit that serves as the network storage area. Data and messages move between workstations through the Winchester unit.

Bos application programs are available in accounting, farming, time-keeping and other areas. Complete details can be obtained from Aid Data Systems Inc., Route 3 Center, POB 750, Millersville, MD 21108, (301) 621-9494. Circle 623 on inquiry card.

Telecommunications Distribution Network

Business Computer Network (BCN) is a telecommunications distribution system that provides access to existing databases and online services such as The Source, Dow Jones, and Western Union's Easy-Link. Databases are accessed from a menu, and BCN automatically signs on the user. Point-to-point communications software that lets different brands of computers work together is one feature of this system. Software downloading, which lets users purchase software at reduced rates

blasting the attackers with your phasers. Graphics and sound complete this adventure.

Moon Hopper requires 32K bytes of memory. It's available on floppy disk or cassette for \$29.95 and \$24.95, respectively. Order it directly from Computerware, Suite 102, 4403 Manchester Ave., POB 668, Encinitas, CA 92024, (619) 436-3512.

Circle 620 on inquiry card.

Accounting Control for Rainbow

The Business Accounting Control Systems (BACS) for Digital Equipment Corporation's Rainbow 100 is marketed by American Business Systems. BACS modules for the Rainbow are single-user programs running under CP/M-86. BACS provides you with interactive menus, extensive error checking, full operator prompting, and the ability to display reports on screen. The five-module series comprises order entry/inventory control, accounts receivable, accounts payable, payroll, and general ledger programs. BACS is written in RM COBOL.

Minimum hardware requirements are 64K bytes of memory, a 24-line by 80-character screen, and a 132-column printer. Further information is available from American Business Systems Inc., 3 Littleton Rd., Westford, MA 01886, (617) 692-2600.

Circle 621 on inquiry card.

What's New?

directly from the BCN computer center, is also available. Additional network services include electronic mail, an information system, and an electronic magazine and newsletter.

Currently, BCN does not charge subscriber fees. A minimum monthly charge of \$5 covers operating ex-

penses and services. A free system disk and a system overview can be obtained by contacting the Business Computer Network, Suite 1220, Gill Plaza, 9601 McAllister Freeway, San Antonio, TX 78216, (512) 340-8201.

Circle 624 on inquiry card.



Classroom Use Possible with Two-Way Network

The Network 216 and the Monitor 16 are at the heart of the first network system designed for complete two-way communications between a master station and its satellites. This system, created by Wolsten's Computer Devices, is designed for any situation in which more than one computer is used at a given time, such as in a computer class. Uploading, downloading, and the ability to send information to a printer are provided. Communication is both video and audio. A dedicated computer is not required.

The Network 216 scans up to 16 active Atari computers and requests if any action, say uploading or sending data to a printer, is required. It automatically proceeds from one computer to another, skipping inactive units. Its data rate

is 19,200 bits per second. The Network 216 uses Atari DOS and can handle up to four disk drives and a printer.

The Monitor 16 expands and enhances the system. It can monitor any of the 16 Ataris individually at the turn of the dial. When used with any television set, the Monitor 16 can display the same video information that is appearing on each computer. Audio communication is made possible through the use of a headset with an attached microphone.

A hard-disk option will be available for the system. For additional information, contact Wolsten's Computer Devices Inc., 99 Washington St., East Orange, NJ 07017, (201) 678-0408.

Circle 625 on inquiry card.

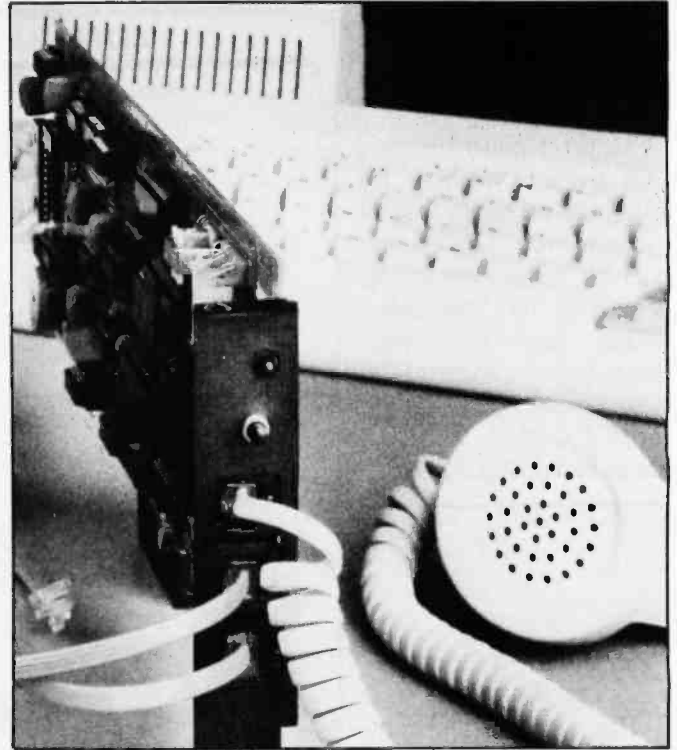

Integral IBM PC, XT Modem

The Bizcomp PC:Intellimodem is an integral Bell 212-compatible modem for the IBM Personal Computer. It can communicate at 300 or 1200 bps (bits per second) and offers integrated voice and data capabilities. Its telephone handset permits program-controlled switching between voice and data communications without requiring a redial. The handset, for example, can be used to monitor communications or to supply voice and Touch-Tone input under control of the Personal Computer. Standard features include auto-dial, auto-repeat dial, and auto-answer. The PC:Intellimodem comes with a menu-driven communications software package that provides more than 50 commands and status checks.

The PC:Intellimodem is marketed through a network of IBM dealers. Its suggested list price is \$499. Contact your local IBM dealer or write to Inquiries Manager, Bizcomp Corp., POB 7498, Menlo Park, CA 94025.

Circle 626 on inquiry card.

IEEE-488-to-Ethernet Interface

An interface board that connects computers with an IEEE-488 GPIB port to an Ethernet local-area network has been announced by Xebec. VLSI technology is used in this board to carry out the physical and data-link control layers of the ISO Ethernet specification. A dedicated microprocessor provides high-level command protocols to the

What's New?

host system software. Unwanted receive packets are automatically discarded. Standard features include a 2K-byte transmit buffer, two 2K-byte receive buffers, automatic retransmission after collision, and an onboard encoder/decoder and transceiver. Software-configurable partial multi-cast address filtering is pro-

vided, and the board offers four software-specified address reception modes. Other software features include a statistics mode and self-test and diagnostics. Full details are available from Xebec, 432 Lakeside Dr., Sunnyvale, CA 94086, (408) 733-4200. Circle 627 on inquiry card.

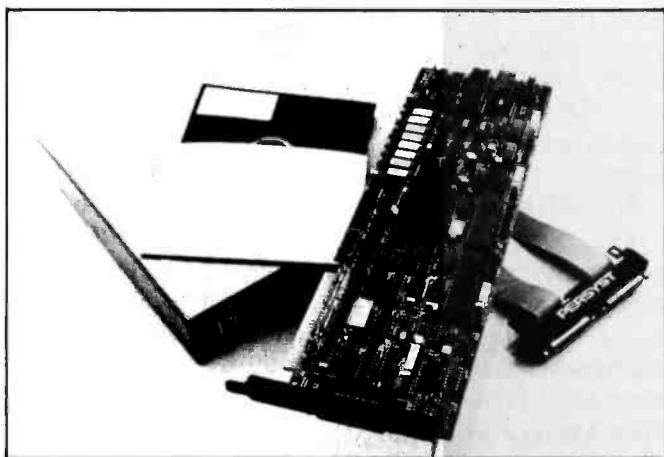

PC to HASP/RJE Communications System

Persyst's DCP/88 Distributed Communications Processor is an integrated hardware and software system that permits IBM Personal Computer and PC XT users to perform HASP/RJE (Houston Automatic Spooling Program/remote job-entry) functions with IBM mainframes. Incorporating an 8088 microprocessor, the DCP/88 controls all communications, sending and receiving data simultaneously with program execution on the PC. It supports 64K bytes of dual-processor RAM and can accommodate asynchronous, bisynchronous, HDLC, and SDLC line protocols. The DCP/88 requires a single card slot and

can function as a parallel processor for program or subroutine execution.

PC/HASP software supports up to seven multi-leaved input and seven output job streams concurrently. As many as six reader streams and six print/punch streams can be initiated from the PC console. Centronics- and Data-products-compatible printers up to 600 lines per minute are supported, and print data can be spooled to disk for off-line printing.

Minimum system requirements are PC-DOS, 64K bytes of memory, a monochrome display, and a disk drive. The suggested price is \$1690; quantity discounts are offered. Contact

Personal Systems Technology Inc., Suite A, 15801 Rockfield Blvd., Irvine, CA 92714, (714) 859-8871.

Circle 628 on inquiry card.

MASS STORAGE

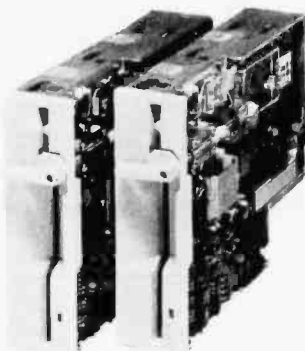

Amdisk-V Drives Plug-compatible with Industry Standard

Amdek Corporation's half-height double-density double-sided Amdisk-V floppy-disk drives are plug-compatible with industry-standard 5¼-inch drives. Designed for original equipment manufacturer applications, the drives offer industry-compatible data-transfer rates, recording formats, and disk rotation speeds. They are said to offer a high random-access speed as a result of a head mechanism built with

a steel-belt access device and ceramic magnetic heads.

Full specifications and pricing information are available from Amdek Corp., 2201 Lively Blvd., Elk Grove Village, IL 60007, (312) 364-1180.

Circle 629 on inquiry card.



Recording Technique Boosts Storage

Sunol Systems' Corvus-compatible mass-storage system uses a Run-Length Limited Coding technique that is said to provide up to 50% more storage than common Winchester disk units. For example, a 12-megabyte Winchester disk after formatting has 10 megabytes of usable storage. Using the same 12-megabyte design and the coding technique, the Sunol unit is claimed to provide 14 megabytes of storage.

Sunol drives have a data transfer rate of 7500 bits per second and feature a status display with current track, head, and sector locations. More than 23 different host adapters for such microcomputers as Apple and Victor are available.

Options include multiplexer and the Omninet local-area network. Contact Sunol Systems, 1072 Serpentine Lane, Pleasanton, CA 94566, (415) 484-3322.

Circle 630 on inquiry card.

What's New?



Large-Capacity 8-inch Fixed Disk

An 8-inch Winchester fixed-disk drive, the D-1100 from Disctron can store 111.5 megabytes of formatted data. System hardware includes mini Winchester heads, plated media, linear voice coil, and closed-loop servo positioning. Data is carried on four thin-film fixed disks, with each surface storing

15.9 megabytes of data. The average access time is 35 milliseconds. In manufacturer quantities, the D-1100 is \$1735. Data sheets are available from Disctron Inc., 1701 McCarthy Blvd., Milpitas, CA 95035. (408) 946-6692.

Circle 631 on inquiry card.

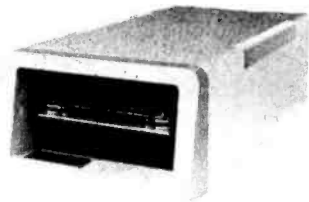

Cartridge Tape System for IBM PC

A cartridge tape subsystem for the IBM Personal Computer is available from Alloy Computer Products. The compact PC-Backup cartridge drive is a 4-track, 6400-bpi unit that can handle 13.4-megabytes of data

per 450 feet of tape or 16.5 megabytes of data on the 555 cartridge. It can serve as a medium for data storage or retrieval or as an on-site Winchester backup. PC-Backup comes with TIP (tape interchange program) software for controlling read, write, and dump operations. Utilities for customizing drive operations are provided.

PC-Backup costs \$1995. For full details, contact Alloy Computer Products, 12 Mercer Rd., Natick, MA 01760, (617) 655-3900. Circle 632 on inquiry card.

Winchester Technology for DEC Professional 350

Digital's RD51, a 10-megabyte 5 1/4-inch Winchester disk, interfaces with the Professional 350. Its average access time is 85 ms (milliseconds); average rotational latency is 8.33 ms. RD51 characteristics include 345 tracks per inch with a density of 9074 bits per inch and a peak data-transfer rate of 5000 bits per second. It's organized with 1224 tracks, each with 16 sectors. RD51 has two data platters and four data surfaces.

The drive alone costs \$1695. Pricing for complete subsystems with controllers is available by request. Contact Digital Equipment Corp., Maynard, MA 01754.

Circle 633 on inquiry card.

Portable Minicassette Program Loader

The MTL-II is a portable, minicassette program loader from Braemar Computer Devices. Intended as an I/O device for RS-232C applications, the MTL-II can store and retrieve approximately 244K bytes of data on a single cassette. This unit reads and writes ANSI-compatible tape for loading programs or remotely collected data through a standard RS-232C port. Light-emitting diodes provide status line and error indication. Other features include a membrane keyboard for control commands, an integral tape deck that uses

50- or 80-foot tapes, and selectable data rates ranging from 150 to 9600 bits per second.

In quantity, the MTL-II costs \$350. Further details are available from Braemar Computer Devices Inc., 11950 12th Ave. S, Burnsville, MN 55337, (612) 890-5135.

Circle 634 on inquiry card.

PRINTERS

Printers for Commodore 64 and VIC-20

Cardco produces the Cardprinter/LQ1, a letter-quality daisywheel printer for the Commodore 64 and the VIC-20. It runs at 14 characters per second (cps) and provides boldface, shadow, and underline printing in normal or proportional spacing modes of 10, 12, or 15 characters per inch. Options include tractor and cut-sheet feeders and a keyboard for direct printing. The suggested retail price is \$599.95.

The Cardprinter/DM1 is also available from Cardco. This dot-matrix impact printer can print 40 columns of text on 3-inch-wide adding-machine roll paper. Full Commodore graphics, 50-cps operation, and high-resolution dot-addressable graphics are featured. It costs \$149.95. For complete specifications, contact Cardco Inc., 313 Mathewson Ave., Wichita, KS 67214, (316) 267-6525. Circle 635 on inquiry card.

What's New?

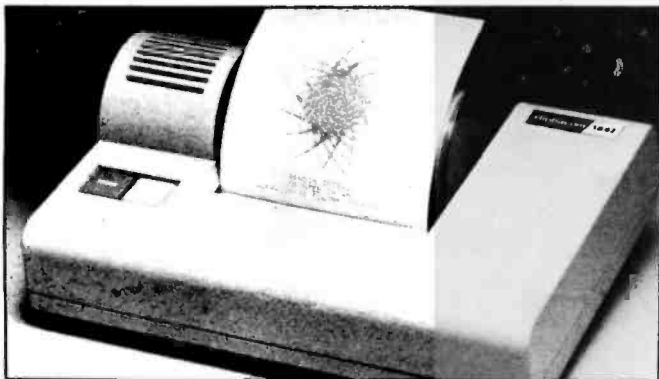

Morrow Introduces Letter-Quality Printers

Three letter-quality, daisywheel printers have been introduced by Morrow. The MP100, MP200, and MP300 offer Shannon text print speeds of 14, 20, or 31 characters per second, respectively. They operate with all Morrow computer systems, including the Micro Decision and the Decision I. Bidirectional printing and noise levels below 65 decibels are standard. Word-processing functions such as boldface,

underlining, centering, subscript, and superscript are supported. Standard multi-strike Silver-Reed ribbons are used. The MP200 and MP300, both 132-column printers, can automatically load single-sheet paper. The prices range from \$595 to \$1195. Complete details are available from Morrow, 600 McCormick St., San Leandro, CA 94577, (415) 430-1970. Circle 636 on inquiry card.

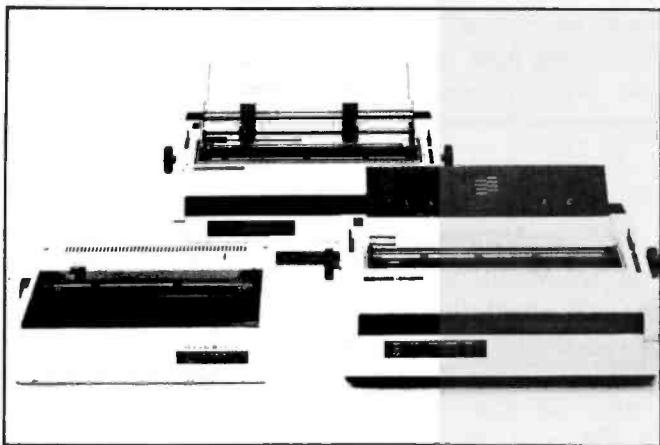

Printer with a Personality

Alphacom is marketing a 40-column thermal printer targeted at the OEM market. The Alphacom 1842 provides applications flexibility through personality (i.e., interface) modules

that manage communications with the host computer, generate characters, and determine the character set and matrix. A 4-pound unit featuring a single-chip microprocessor

controller and an Olivetti print mechanism, the 1842 is housed in an impact-resistant case, measuring 10½ by 7½ by 4 inches. It runs at 2 lines per second in either a graphics or character mode.

With an interface module, the single-unit price is \$199.50. Interface modules are available for Centronics, IEEE-488, and RS-232C ports. Teletext and videotex versions are in production. For information, contact Alphacom, 2323 South Bascom Ave., Campbell, CA 95008, (408) 559-8000. Circle 637 on inquiry card.

Low-Cost Letter-Quality Printer

The Transtar Model 130 is advertised as the first daisy-wheel printer to provide letter-quality print and full word-processing functions for less than \$900. Produced with users of IBM PC, Apple, and Osborne computers in mind, the Model 130 is compatible with all word-processing software that uses Diablo routines. An auto-load feature lets you load cut-sheet paper to one of four switch-selectable positions designed for most common printing functions. Fully formed characters are printed, bidirectionally, at 18 cps (characters per second) Shannon text rating; the maximum speed is 20 cps. Cartridge ribbons are available in cloth or single- or multistrike Mylar film, and 96-character plastic print wheels come in pica,

elite, or proportional styles. Proportional spacing is supported if your word processor is so equipped.

Two versions of the printer are offered. The Model 130P is an 8-bit Centronics-compatible parallel interface. It costs \$895. The Model 130S works with RS-232C serial interfaces. It has a standard 2K-byte print buffer and switch-selectable transmission rates ranging from 300 to 2400 bits per second. The Model 130S supports the DTR busy protocol, with XON/XOFF and ETX/ACK protocols under DIP switch control. The suggested retail price is \$950. A bidirectional tractor-feed option lists for \$149. For more details, contact Transtar, 2110 116th NE, POB C-96975, Bellevue, WA 98009, (206) 454-9250. Circle 638 on inquiry card.

PERIPHERALS

16/32-Bit Processor Boosts Apple's Speed

The PDO II is said to increase the Apple II/III's computational speed from 200 to 2000 percent. Produced by Enhancement Technology Corporation, the PDO II incorporates a 16/32-bit MC68000 microprocessor and 256K bytes of RAM and provides such productivity capabilities as multiple printer/communications buffering, pseudo-disk functions, and track buffering. Most standard Applesoft BASIC programs are supported, as are advanced 16/32-bit software,

What's New?

Apple DOS 3.3, and the UCSD p-System interpreter.

RAM memory expansion to 1 megabyte and Unix-like operating systems are in the works. PDQ II costs

\$1595. Contact Enhancement Technology Corp., POB 1267, Pittsfield, MA 01202, (413) 445-4219. Circle 639 on inquiry card.

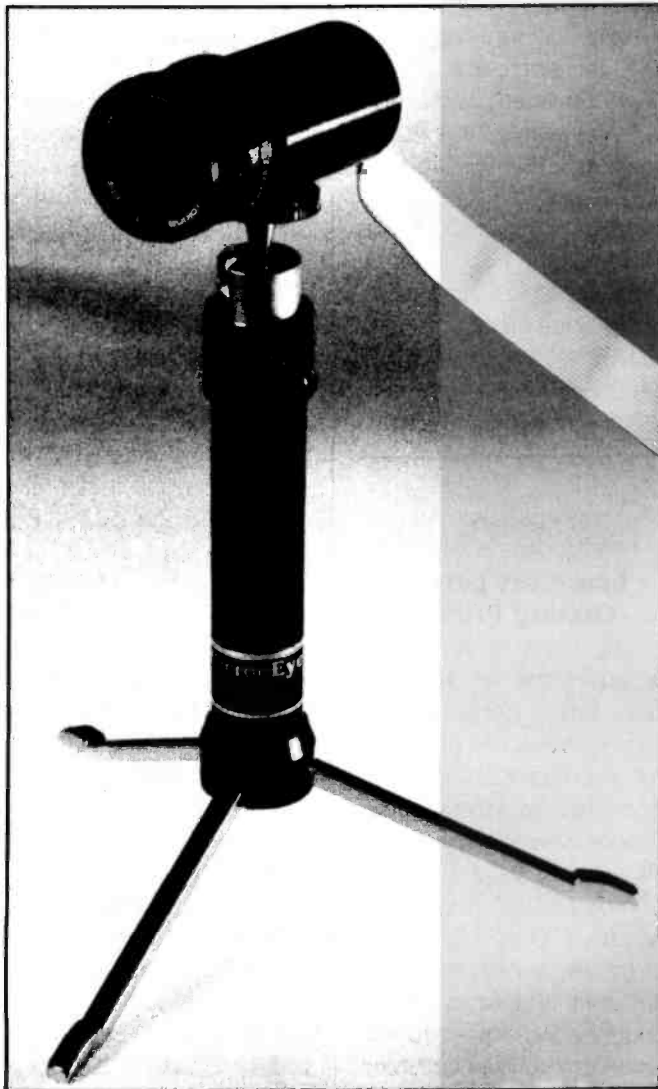

Microcomputer Vision System

The Microneye vision system transmits images to your computer for mass storage of graphics displays and image analyses. Possible applications include robotics, security, and text recognition. It's capable of 256 by 128 resolution and operating speeds of up to 15 frames per second.

Microneye is currently

available for the Apple II Plus and IIe, IBM Personal Computer, Commodore 64, and the Radio Shack TRS-80 Color Computer. It lists for \$295. For complete specifications, contact Micron Technology Inc., 2805 East Columbia Rd., Boise, ID 83706, (208) 383-4050.

Circle 640 on inquiry card.



Telephone/Terminal Runs Two Lines

The Displayphone is a two-line business telephone combined with a 7-inch terminal screen produced by Northern Telecom and distributed by May-Craft Information Systems. This device is designed for accessing databases such as The Source and Dow Jones, even while you're on another line. Displayphone provides an internal speaker/phone, a call directory, call timer, an internal 300-bit-per-second (bps) modem, and an electronic clock

with time and date. The screen format is 24 lines by 80 columns. Displayphone supports a separate printer and comes with an external RS-232C data connector offering speeds of up to 1200 bps.

Further information on the Displayphone is available from May-Craft Information Systems Inc., 4312 Beltwood Parkway S, Dallas, TX 75234, (800) 527-7456; in Texas, (214) 392-3766.

Circle 641 on inquiry card.

16-Bit SMC-70 Upgrade Offers 256K RAM

Sony Microcomputer Products is marketing a 16-bit upgrade for its SMC-70 microcomputer. The Supercharger converts the SMC-70 into a 16-bit system carrying 256K bytes of on-board RAM (random-access read/write memory). Based on Intel's 8086 microprocessor operating at 5 MHz, the Supercharger is capable of supporting CP/M and MS-DOS concurrently. It measures 14 $\frac{3}{8}$ in-

ches wide by 6 $\frac{1}{4}$ inches deep by 4 $\frac{5}{8}$ inches high. Changes to SMC-70 peripherals are not required.

Options available include an additional 512K bytes of RAM and an 8087 floating-point mathematics processor. The Supercharger costs less than \$1000. Sony Microcomputer Products, Sony Dr., Park Ridge, NJ 07656. Circle 642 on inquiry card.

What's New?



Computer Image Recorder Snaps Instant Photos

The Polaroid Palette, an interactive film recorder, produces high-quality 35-mm slides and instant photographs of computer graphics images in either black-and-white or color. Featuring a flat-faced, medium-resolution monochrome video screen with a tricolor filter wheel, the Palette allows even monochrome displays with graphics capabilities to produce color prints for presentations, displays, record keeping, or working copies. It connects to the computer through black-and-white video and RS-232C lines. It's supplied with interactive software for matching exposure parameters to the film and allowing the user to control color selection and location. The software also lets you transfer images from the display to the film without modification.

Palette can be used with Apple II Plus, Apple IIe, and

IBM Personal Computers. Several graphics packages are supported. The suggested retail price is \$1300, including software, a 35-mm camera back and an adapter plate, and transparency system hardware. Further details are available from Polaroid, 575 Technology Square, Cambridge, MA 02139, (617) 577-2000.

Circle 644 on inquiry card.

Eight-Color, High-Resolution RGB Monitor

The Model SC-300 color-display monitor is compatible with Apple II/III, IBM PC, NEC, and other popular computers. A 13-inch red/green/blue high-resolution monitor, the SC-300 offers a display format of 80 characters by 25 lines in a 5- by 7-dot grid. Key

specifications include eight colors plus intensity (total 16 colors), a digital amplifier video circuit, and a center resolution of 700 dots (minimum).

The SC-300 monitor costs \$899. Complete technical specifications are available from Sakata U.S.A. Corp., 651 Bonnie Lane, Elk Grove Village, IL 60007, (800) 323-6647; in Illinois, (312) 593-3211. Circle 645 on inquiry card.

SYSTEMS

Concurrent Processing

The Xerox 16/8 Professional Computer combines 16- and 8-bit microprocessors for concurrent processing of two tasks. The 16-bit operating systems are CP/M-86 and MS-DOS; CP/M-80 handles the 8-bit work. The 16-bit Intel 8086 processor provides 128K bytes (expandable to 256K bytes) of user memory, while the 8-bit Zilog Z80A has 64K bytes. Standard features include a 12-inch black-and-white display with a 24 by 80 format, two serial and two parallel ports, and a low-profile keyboard with 12 user-definable keys, 6 system function keys, a 10-key numeric keypad, cursor keys, and a Help key. Video attributes such as blinking characters, high and low intensity, inverse video, and graphics are provided. Storage options, which can be tailored to specific needs, include two single-or

double-sided 5¼- or 8-inch floppy-disk drives and a 10-megabyte fixed-disk drive that comes with a double-sided 8-inch disk drive.

Two letter-quality Diablo printers, 5- or 10-slot expansion modules, Ethernet network communications, and a variety of applications software are available as options. Prices begin at \$3395; quantity discounts are offered. Contact Xerox, Office Products Division, 1341 West Mockingbird Lane, Dallas, TX 75247. Circle 646 on inquiry card.

Automated Language System

ALPS, Automated Language Processing Systems, is a multilingual translator and authoring workstation capable of serving as a master station in a network or as a stand-alone unit. The basic ALPS word processor lets you work in more than 100 Roman-alphabet-based languages and offers continually accessible dictionary-building and lookup capabilities. This system features multiple-window 80- and 130-column display screens, a letter-quality multilingual printer, and multilingual keyboards. Floppy-disk and hard-disk storage capacities range from 10 to 300 megabytes. Network and telecommunications capabilities permit access to term banks and terminology-exchange networks.

What's New?

A full range of optional integrated writing aids, multiple unit configurations, and financial software are available. For

complete details, contact ALPS, 190 West 800 North, Provo, UT 84601, (801) 375-0090. Circle 647 on inquiry card.

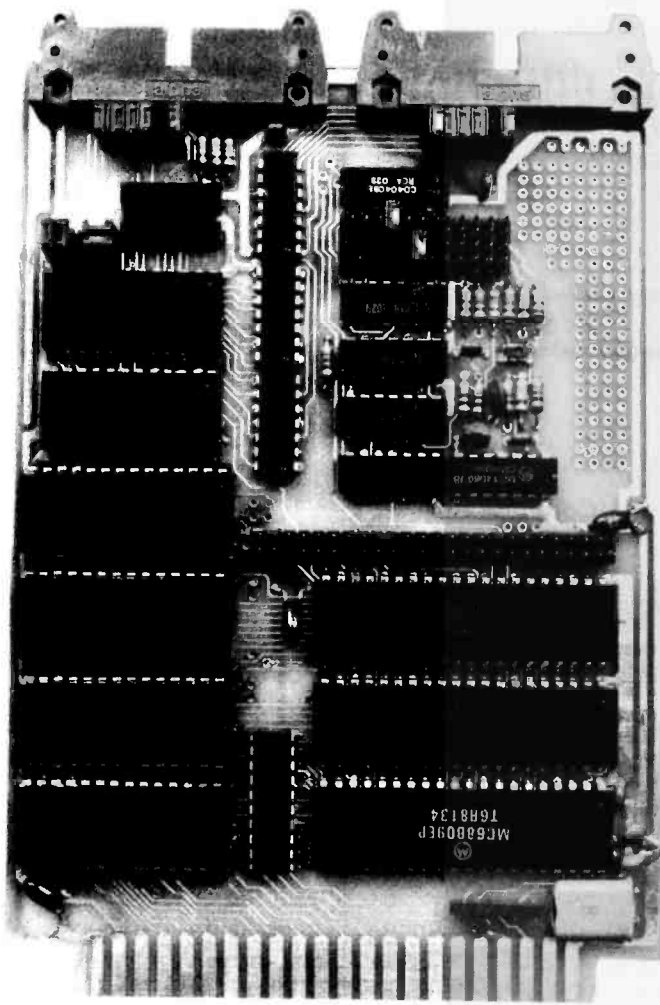

Single-Board 6809 Computer

The 6809 Control Module from Wintek Corporation is designed for such applications as dedicated control, protocol conversion, and robotics. This system comes with a watchdog timer, real-time clock, two RS-232C ports, four parallel ports with handshaking, and up to 64K bytes of RAM and EPROM. It's built on an industry-standard 4½- by 6½-inch card, and it's

compatible with all Wintek I/O modules.

Options include additional ROM or CMOS RAM memory modules and 6809 development software. Prices begin at \$245; quantity discounts are available. A manual alone costs \$5. For full details, contact Wintek Corp., 1801 South St., Lafayette, IN 47904, (317) 742-8428. Circle 649 on inquiry card.

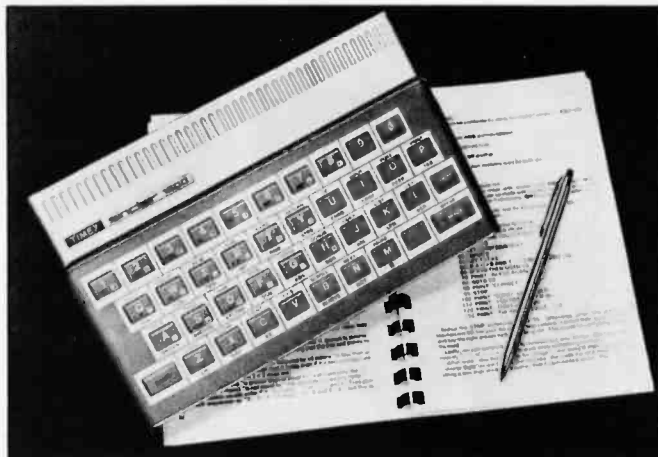

16K-Byte Computer for Less Than \$80

The Timex/Sinclair 1500, a 16K-byte computer, has black-and-white graphics capabilities, a 40-key type-writer-like keyboard, and the ability to use either standard audio cassettes or mini-cartridge software. Other features include 22 graphics and 22 special-character keys, Extended

BASIC, and compatibility with software and peripherals available for the TS1000. RAM memory is expandable to 32K bytes.

The suggested retail price is \$79.95. Contact Timex Computer Corp., Middlebury, CT 06762. Circle 650 on inquiry card.

System Expands for Multiple Users

Cromemco's CS-3A series of general-purpose micro-computers offers multiuser, multitasking capabilities. The basic CS-3A comes with a Z80A, 64K bytes of memory, two slimline 8-inch Tandon disk drives with a total of 2.4 megabytes of storage, and CROMIX and CDOS operating systems.

System expandability begins with a 21-slot backplane and a line of bus-compatible board products. A dual-processor option couples the Z80A with the 68000 microprocessor. Other hardware available includes up to 4 megabytes of user memory and 21 megabytes of fixed-disk Winchester storage. Soft-

ware options such as error checking and correcting memory and a multiuser, multitasking operating system are offered. C, LISP, FORTRAN, COBOL, Pascal, BASIC RPG-II, and RATFOR are supported. When equipped with dual processors, the CS-3A can run FORTRAN-77 and Level II COBOL.

The basic CS-3A system costs \$6995. The dual-processor version with 256K bytes of memory is \$7995. Full specifications are available from Cromemco Inc., 280 Bernardo Ave., POB 7400, Mountain View, CA 94039, (415) 964-7400.

Circle 651 on inquiry card.

What's New?



Color Computer for Beginners

The Radio Shack TRS-80 Micro Color Computer Model MC-10 is targeted at first-time computer users. A 4K-byte machine that's software-compatible with Color BASIC, the MC-10 offers low-resolution graphics, keyword input using two keystrokes, and text and graphics displays in a 32-character by 16-line format. For expansion, serial and cassette ports are provided. The MC-10 connects to standard color or

black-and-white televisions through its built-in RF modulator.

A plug-in 16K-byte memory-expansion module will soon be available. With a manual and monitor-connection cables, the MC-10 costs \$119.95. For more information, contact your local Radio Shack Computer Center or Radio Shack, 1800 One Tandy Center, Fort Worth, TX 76102.

Circle 652 on inquiry card.

Software Library Comes Standard

The Multiplan electronic spreadsheet, the Wordstar 3.3 word processor, Mailmerge 3.3, CBASIC, CP/M Plus, a VT-100 terminal emulation package, and Digital Research's GSS-Graph graphics package and the GSX-80 graphics-device driver comprise the software library supplied with the Visual 1050 Personal Computer. System hardware is made up of two 400K-byte floppy-disk drives, 96K bytes of RAM, a high-resolution (640 by

300), bit-mapped monochrome display, a detached 93-key keyboard, and printer, modem, and Winchester disk-expansion ports.

A plug-in, dual-port serial card, 64K bytes of memory, and a 5-megabyte hard-disk are available as options. The Visual 1050 lists for \$2695. For more information, contact Visual Technology Inc., 540 Main St., Tewksbury, MA 01876, (617) 851-5000.

Circle 653 on inquiry card.

IBM PC Look-Alike

The Sanyo MBC 550 is a 16-bit IBM Personal Computer look-alike. Standard features include an 8088 microprocessor, 128K bytes of memory, a 160K-byte floppy-disk drive, color graphics capabilities, and a Centronics-type printer port. Supplied software includes Sanyo BASIC, utilities, a word processor, and diagnostics. MS-DOS, an 8087 mathematics processor, 320K to 640K bytes of disk storage, monochrome or color monitors, and an extra 128K bytes of memory are some of the options available.

Prices for the MBC 550 begin at \$995. Contact Sanyo Business Systems Corp., 51 Joseph St., Moonachie, NJ 07074, (201) 440-9300.

Circle 654 on inquiry card.

16-Bit Computer Suited for Home and Business

A 16-bit desktop computer, the Toshiba T300 is designed for personal and business use. This machine has an 8088 processor, 192K bytes of memory, a 103-key detached keyboard, three video interfaces, a serial RS-232C port, and a Centronics-compatible parallel port. Three display monitors are offered: a 12-inch green screen, an 8-color 14-inch version, and a 14-inch display with 16 colors available from a palette of 256. Each tilt-and-swivel monitor has a dot-addressable resolution of 640 by 500.

Mass storage is provided by one or two slimline 5¼-inch double-density, double-sided floppy-disk drives, each with a capacity of 640K bytes. MS-DOS and T-BASIC 16 are standard, and CP/M-86 and CBASIC-86 are available as options. RAM memory is expandable to 512K bytes. For full details, contact Toshiba America Inc., Information Systems Division, 2441 Michelle Dr., Tustin, CA 92680, (714) 730-5000.

Circle 655 on inquiry card.

FOREIGN

Adjustable Computer Tables

Emmein B. V. is exporting computer terminal and keyboard tables with electronically controlled height adjustments. Each high-grade steel table has two independently adjustable leaves that permit the keyboard and terminal to be raised or lowered. Lifting systems are concealed behind a panel, and each table comes with a cable duct for the terminal's cables and power supply.

Three models, each with a different adjustment method, are offered: the electronic model permits recording of the desired height for automatic adjustments; the push-button model uses electric motors and screw drives; and the mechanical model adjusts each leaf using balanced weights.

Sides leaves are available for each table. For informa-

What's New?

tion, write to the Consulate General of the Netherlands, Economic Section 6a2/82, One Rockefeller

Plaza, New York, NY 10020.
Circle 656 on inquiry card.

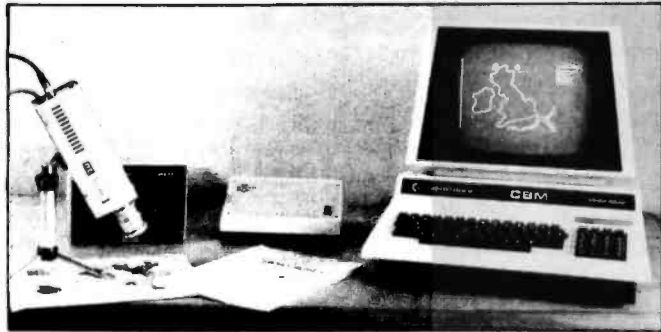

Vision Systems

Digithurst Ltd. sells two vision systems for micro-computer applications ranging from education to artificial intelligence. The Microsight 1 is a CCTV-based unit that uses a Micro Eye camera interface to send 8-bit digitized video images to a computer. The Microsight 2, based on a solid-state camera, employs a 128 by 128 CID sensor to capture an image and a high-speed interface to pass the image back to the computer either as 8-bit digital video or as threshold video.

Both systems use a command processor and disk I/O and camera-control routines. Other software permits interactive adjustments of camera settings and display of facsimile and binary images. A boundary/edge detection program is included. The Microsight 1 costs £499. The Microsight 2 is £199. Contact Digithurst Ltd., Leaden Hill, Orwell, Royston, Hertsfordshire SG8 5QH, England; tel: (0223) 208926.

Circle 657 on inquiry card.

P-system for IBM PC

Network Consulting has configured a version of the UCSD Pascal p-System for the IBM Personal Computer. Purported to run one to five times faster than its competition, this system features a rewritten 8088 interpreter and floating-point programs that manipulate real numbers. Its long-integer support is said to be three to five

times faster than previous systems.

Dealer prices begin at \$845. Benchmarks and marketing information are available from Network Consulting Inc., Suite 110, Discovery Park (Willingdon Site), 3700 Gilmore Way, Burnaby, British Columbia V5G 4M1, Canada, (604) 430-3466.

Circle 658 on inquiry card.

Joystick Port for VIC

MFJ Electro Enterprises offers Commodore VIC-20 users an add-on port for a second joystick for programming and running two-player games. Programming instructions and a sample two-player game on cassette are provided in this \$21.50 package. Contact MFJ Electro Enterprises, POB 13076, Kanata, Ontario, K2K 1X3 Canada, (613) 592-2962.

Circle 659 on inquiry card.



Graphics Display Terminal

Nippon Computer Company's NJC-M1212 graphics display terminal is suitable for business graphics and graphics information retrieval. Standard features include a 12-inch green screen, 640- by 486-dot resolution, 1-microsecond per dot high-speed drawing, three communications ports, and a Tektronix 4010/4014 emulator. The complete package is provided with a graphics processor, communications software, and a keyboard.

The list price is \$2600. Contact Nippon Computer Co. Ltd., Naito Building, Nihonbashi Hamacho 2-25-1, Chuo-ku, Tokyo 103, Japan; tel: 03-669-3066; Telex: 0-2523475.

Circle 660 on inquiry card.

MISCELLANEOUS

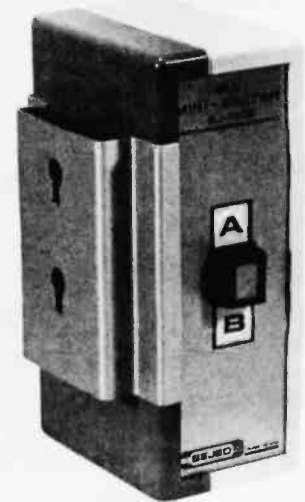

RS-232C Switch and Indicating Adapter

Bejed's Model BJ-1208 EIA Mini-Switch provides manual switching between many RS-232C devices, such as a modem or computer. Common leads 2, 3, 4, 5, 6, 8, and 20 are switched, while 1, 7, and 10 are hard-wired through. Its nonlocking push button changes color when operated. In single units, the BJ-1208 costs \$98, including mounting hardware.

Also available from Bejed is the Model BJ-1218 Indicating Adapter. Its LEDs provide the status information on RS-232C data leads 2, 3, 4, 5, 6, 8, and 20. All other leads are carried through without indication. The Model BJ-1218 is offered in two versions for different connector arrangements. Either model costs \$35.

Quantity discounts on these devices are offered. For more information, contact Bejed Inc., 4824 North-east 42nd, Portland, OR 97218, (503) 281-8153.

Circle 661 on inquiry card.

What's New?

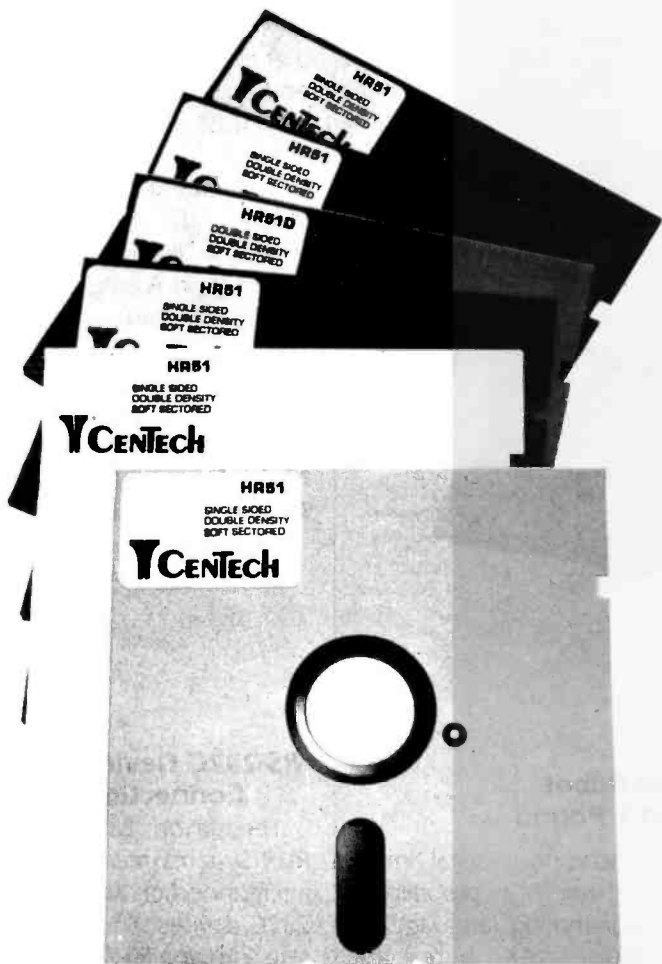

Colored-Coded Disks Aid Filing

Colored disks from Cenna Technology help you file, code, and identify your programs. Five different colors are supplied with each 10-pack: red, orange, yellow, green, and blue. Other color combinations are available on request. The disk cartridge material is high-quality Homopolymer PVC. Single-sided, double-sided, and quad-density 5¼- and 8-inch disks are offered.

The suggested end-user price for a 10-pack of single-sided 5¼-inch disks is \$34.95. Dealer pricing is available. Contact Cenna Technology Inc., 183 Cot-

tage Ave., Sandy, UT 84070, (801) 261-1600. Circle 662 on inquiry card.



Bulk EPROM Eraser Works in Minutes

The Memorse C-25 erases up to 25 EPROMs in 10 minutes. It comes with

a filtered viewport, high-intensity grid lamp, 60-minute timer for simplified exposure settings, and a safety interlock. In single units, the C-25 costs \$395. A desktop version capable of erasing 1 to 8 EPROMs, the Model DE-4 costs approximately \$78. Volume discounts are available. Contact UVP Inc., 5100 Walnut Grove Ave., POB 1501, San Gabriel, CA 91778, (213) 285-3123. Circle 663 on inquiry card.

Terminals Upgraded to CP/M Systems

The Microfit Instant Computer upgrades your Televideo or Lear Siegler terminal into a CP/M system. Microfit is a single-board 64K-byte computer using a Z80A processor and offering two RS-232C ports, a Centronics parallel interface, and a floppy-disk controller for up to four 5¼- or 8-inch disk drives. Storage capacities range from 200K bytes to 5 megabytes.

Microfit will convert Televideo Models 910, 912, 920, 925, and 950 terminals and Lear Siegler Models ADM-3A and ADM-5. It costs \$1595, which includes CP/M and dual 720K-byte double-sided floppy-disk drives. Full details are available from Data Systems Marketing, 5710 Ruffin Rd., San Diego, CA 92123, (800) 854-2684; in California, (800) 532-3717. Circle 664 on inquiry card.



Joystick for the Apple and IBM PC

The Mach III joystick from Hayes Products is connector-compatible with Apple II/IIe and IBM Personal Computers. It features a gimble with spring centering or free-floating in any or all four X,Y coordinates, which provides an arm alignment with 360° movement. Fire control buttons are located on the deck of the control unit and on the end of the joystick.

For the Apple II, the Mach III costs \$49.95. The Apple IIe and IBM Personal Computer version is priced \$5 higher. Contact Hayes Products, 1558 Osage St., San Marcos, CA 92069, (714) 744-8546.

Circle 665 on inquiry card.

Synthesizer Creates Stereo Effect

The Stereo Composer is a music-synthesis system for the Radio Shack Color Computer and the TDP-100 from Speech Systems. Stereo Composer comes with software that lets you program four voices with a seven-octave range. Of the four voices, two are di-

What's New?

rected toward two separate channels, creating a stereophonic effect. Dotted, double-dotted, eighth, quarter, and standard triplet notes are supported. Voices can be moved between speakers, and music can be played at any tempo in any key. Tempo and key can be changed as the music is playing. System hardware features individual 8-bit D/A (digital-to-analog) converters to drive two audio power amplifiers which, in turn, run a pair of loudspeakers. Output can be connected to a home stereo system for greater stereo effect.

The Stereo Composer costs \$119.95. It's available from Speech Systems, 38 West 255 Deerpath Rd., Batavia, IL 60510, (312) 879-6880. Circle 666 on inquiry card.

Printer Traveling Cases

Travelmaster's line of printer carrying cases features blow-molded double-wall construction, luggage-style handles, and locking latches. Cases are available for Epson Microlines, Okidata ML-80 series, C. Itoh Prowriter, and NEC 80-character printers. Suggested retail prices range from \$79.95 to \$94.95. For more information, contact Southern Case Inc., Travelmaster Division, 2315 Laurelbrook St., POB 28147, Raleigh, NC 27611, (800) 334-0551; in North Carolina, (919) 821-0877. Circle 667 on inquiry card.



Programmable Robot Lifts More Than 1 Pound

The Microbot Alpha, a self-contained, programmable robot, can lift payloads of up to 1½ pounds. Alpha's arm, which has an 18-inch reach, offers such motions as 330° base rotation, 140° shoulder and elbow bends, 360° wrist rolls, and 180° wrist pitch. A cable-operated mechanical gripper uses timing belts coupled with metal pulleys to transmit the torque of stepper motors. Operating speeds as high as 20 inches per second are achievable, and Alpha can be programmed for acceleration and deceleration modes. Its repeatable position accuracy is plus or minus twenty-thousandths of an inch. An onboard computer can be set to retain 227 working positions. In addition, Alpha can be programmed with other computers through an RS-232C

asynchronous serial interface using a proprietary programming language. It includes 4K bytes of EPROM and EEPROM and 1K bytes of RAM.

In single units, the Alpha robot costs \$8500. More information is available from Microbot Inc., 435-H Ravendale Dr., Mountain View, CA 94043, (415) 968-8911.

Circle 668 on inquiry card.

Printwheel Cleaning System

Your printwheel's plastic and metal spokes and typeface crevices can be safely cleaned with the Copy-source Printwheel Cleaning Kit. Spill-free wands are used to dispense 0.6 milli-

liters of a cleaning solvent that eliminates plastic glaze and dissolves caked magnetic dust, ink, and dirt.

Each self-contained Copysource kit contains 10 wands, 10 lint-free dry wipes, a cleaning station, and a tray. A single kit is \$12.95. A case (10 kits) costs \$89.50. To order, contact Choep-Stevens Paper Co., Department 202, 1800 18th St., Detroit, MI 48216, (313) 237-0300. Circle 669 on inquiry card.

RS-232C Devices Aid Connections

The Jaxon Division of RVR Systems markets two interconnection aids for RS-232C devices. The Owl inserts into any RS-232C port and indicates whether the device type is DTE (terminal) or DCE (modem). If left inline, the Owl indicates data transfers.

When inserted between RS-232C lines, the LBS-1 loopback switch lets you connect DTE to DTE, DCE to DCE, or DTE to DCE. Each connector operates LBS-1, except pins 2 and 3. It comes with descriptions of DATA, CONTROL, and TIMING lines.

These devices do not require power, nor will they load lines. The Owl costs \$39.95. LBS-1 is \$29.95. Both prices include shipping and handling originating from Jaxon, RVR Systems, POB 265, Dewitt, NY 13214.

Circle 670 on inquiry card.

What's New?

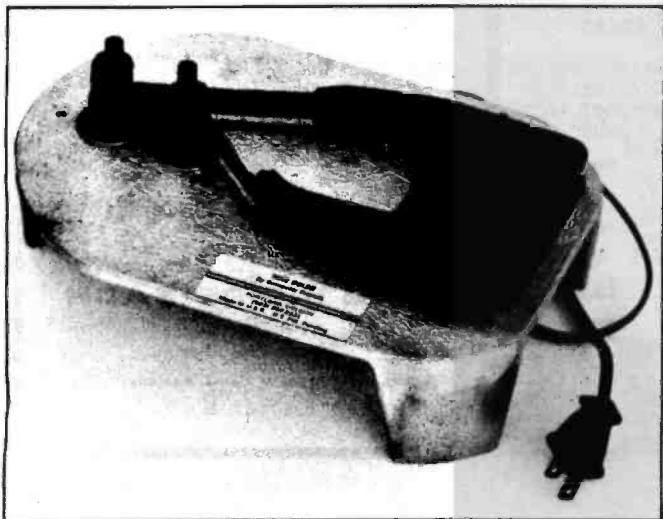

Automatic Ribbon Reinker

The Mac Inker from Computer Friends automatically reinks ribbons for any printer. Users merely load their ribbon cartridge, and Mac Inker meters out the correct amount of ink, evenly distributing it across the ribbon.

Mac Inker is available

with multicolored inks and with cartridge-loading stations for most current printers. It costs \$54.95. For full details, contact Computer Friends, 100 Northwest 86th Ave., Portland, OR 97229. (503) 297-2321.

Circle 671 on inquiry card.

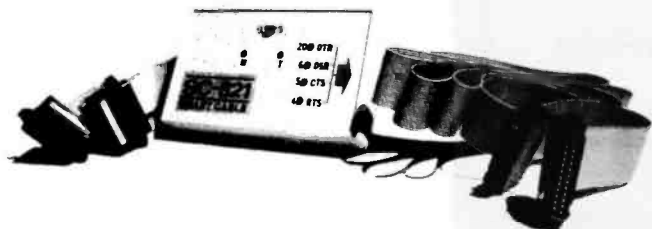

RS-232C Cable Offers a Handshake to Any Peripheral

The SC821 Smart Cable from IQ Technologies is an intelligent RS-232C interface cable that can hook any computer to any peripheral with the flip of a single switch. This device is designed with onboard logic circuitry that determines which RS-232C interface lines are used by a computer and a peripheral, and it adjusts the hand-

shaking signals accordingly. This eliminates the need for breakout boxes, cable redesign, and inventories of custom cables. Possible applications include system integration and field service.

The SC821 connects all the handshaking lines in a specific application in addition to CTS, DTS, DTR, and DSR. It functions at data

rates of up to 19,200 bits per second. In the event of a hardware or software problem, the SC821's indicator lights point out the device that is disabling the data transfer. The cable is transparent to data rate, word length, and error and data codes. It costs \$245 and can be ordered from IQ Technologies Inc., Suite 308, 11811 Northeast First St., Bellevue, WA 98005, (206) 451-0232.

Circle 672 on inquiry card.

Disk Storage Containers

Diskfiles provide efficient disk storage for up to 125 floppy disks. Disk compartments are separated by removable inserts, and five color-coded tab dividers are provided. The unit features dimensions similar to most disk drives and a dark, see-through acrylic finish.

Diskus Jr., which holds 75 disks, costs \$39.95. Holding up to 125 disks, Diskfiles costs \$59.95. An 8-inch version capable of handling 115 disks is \$79.95. Add \$3.75 ship-

ping and handling to each order. Contact Diskus Products, 6003 Bandini Blvd., Los Angeles, CA 90040, (213) 726-3088. Circle 673 on inquiry card.

Stand Lifts PC for Stowing Keyboard Safely

The P. C. Stand lifts the IBM Personal Computer so that you can safely stash the keyboard under the unit. The P. C. Stand allows the keyboard cable to be efficiently routed under the system, or it can be used for positioning the monitor at a more comfortable viewing height. This welded steel unit is finished to complement the IBM's color and texture. It measures 22 inches wide by 3 inches high by 14 inches deep. The suggested price is \$34.95, plus \$2 shipping and handling. The P. C. Stand can be ordered from Personal Computer Accessories, 4456 Partridge Court, San Jose, CA 95121, (408) 578-7798. ■

Circle 674 on inquiry card.

Where Do New Products Items Come From?

The information printed in the new products pages of BYTE is obtained from "new product" or "press release" copy sent by the promoters of new products. If in our judgment the information might be of interest to the personal computing experimenters and homebrewers who read BYTE, we print it in some form. We openly solicit releases and photos from manufacturers and suppliers to this marketplace. The information is printed more or less as a first-in first-out queue, subject to occasional priority modifications. While we would not knowingly print untrue or inaccurate data, or data from unreliable companies, our capacity to evaluate the products and companies appearing in the "What's New?" feature is necessarily limited. We therefore cannot be responsible for product quality or company performance.

wabash®

Flexible Diskettes

**6 Year Warranty - 100% Certified
DELIVERED PRICES**

5 1/4" \$175 SINGLE SIDE SINGLE DENSITY 48 TPI W/HUB RING Packed 10 per Soft Pack each	BULK SSSD \$140 100/Case White Envelope W/HUB RING each
5 1/4" \$210 SINGLE SIDE DOUBLE DENSITY 48 TPI W/HUB RING Packed 10 per Soft Pack each	BULK SSDD \$170 100/Case White Envelope W/HUB RING each
5 1/4" \$310 DOUBLE SIDE DOUBLE DENSITY 48 TPI W/HUB RING Packed 10 per Soft Pack each	BULK DSD \$270 100/Case White Envelope W/HUB RING each

Free shipping in continental USA. Call for quantity discounts. We accept money orders, certified checks, VISA and MasterCard. Personal checks accepted, but take two weeks to clear bank. N.D. add 4%.



Software Services™

1326 - 25th St. S., Suite D
Fargo, ND 58103
1-800-MEGA-BIT

Circle 364 on inquiry card.

Now, Interconnect Any Two RS232 Devices

American Made

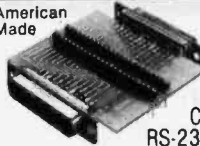

WIRING ADAPTER
\$24.95

Connects any two RS-232 devices in any pattern. Temporary or permanent. Comes complete with ten plug-in jumper wires. Wiring Adapter just \$24.95 plus \$1.75 for postage and handling, (IL res. add 5% sales tax); we accept MC, Visa, and Purchase Orders from rated firms. Get FREE illustrated catalog of interface and monitoring equipment.



B&B electronics

P.O. Box 475 B • Mendota, IL 61342
Phone: (815) 539-5827

Circle 41 on inquiry card.

MC68000

MACHINE CODE TRANSLATOR (DISASSEMBLER)
CROSS ASSEMBLER

FORTRAN Source Programs on

- Magnetic Tape (800 or 1600 BPI)
- Diskette (SS/SD Ind. Std.)

Easy Installation on any System with FORTRAN Compiler

INSTRUCTIONS and EXAMPLE RUNS

\$149.95 EACH

James M. Coln & Associates
P.O. Box 270340
Dallas, Tx 75227

Circle 75 on inquiry card.

AUGUST SPECIALS

	LIST	SALE
dBASE II	700	465
WORDSTAR	495	345
MICROSOFT		
BASIC COMPILER	395	305
ZORK I, II, or III	40	28
AMDEK COLOR I	379	319
EPSON FX 80	699	615
EPSON MX 100	849	695
DISKETTES 5 1/4" SSDD		22

P.O. BOX 64844
DDE INC. DALLAS, TX 75206
1-800-527-7127

IN TEXAS 1-214-525-3230

PRICES GOOD THROUGH 08/31/83
Please Include 3% for Shipping (minimum \$2.00), or 5% for Blue Label (minimum \$3.00).
In Texas Add 5% Sales Tax
MASTERCARD, VISA,
CHECK (Allow 10 Days), or COD (Add. \$2.00)

Circle 127 on inquiry card.

SMITH-CORONA TP-1

Letter Quality • Daisy Wheel Printer



- Serial Or Parallel Interface
- Microprocessor Electronics

Order Toll Free:
Free Shipping

\$479

1-800-531-5475 (Outside Of Texas)
(512) 250-1523 (In Texas)

CompuAdd Corp.

13010 Research Blvd., Suite 101
Austin, Texas 78750

Circle 83 on inquiry card.

C/UNIX™

\$4.00 each

- **C Language and the UNIX™ Library Functions** detailed in a pocket sized booklet. \$4.00 each, \$10 for 3, or \$3 each for 10 or more.
- **C Language Reference Card** \$2.50 each, \$4 for 2, \$1.75 each for 10 or more.
- **UNIX™ Command Summary** also available.

UNIX™ is a trademark of Bell Laboratories.

SSC

P.O. Box 806
Mercer Island, WA 98040

VISA/MasterCard orders call
(206) 323-8751

Circle 368 on inquiry card.

8" DISKETTES ALSO AVAILABLE

TOP QUALITY 5 1/4" DISKETTES

SPECIFY SOFT, 10 or 16 SECTORS

	\$/10	\$/50	\$/100
wabash			
SSDD (M13A411X)	23.00	112.00	218.00
DSDD (M14A411X)	30.00	146.00	286.00
control data			
SSDD (CDDC1242-00)	22.00	106.00	210.00
DSDD (CDDC1244-00)	30.50	147.00	290.00
3M scotch			
SSDD (3M 744D-0)	22.00	109.00	213.00
DSDD (3M 745-0)	31.00	150.00	295.00
verbatim			
SSDD (MD525-01-18158)	25.20	124.00	245.00
DSDD (MD550-01-18188)	36.50	180.00	355.00
maxell			
SSDD (MAX-MD-1M)	28.95	140.00	270.00
DSDD (MAX-MDZ-DM)	39.00	192.00	380.00
dysan			
SSDD (DYS 104-1D)	36.00	177.00	350.00
DSDD (DYS 104-2D)	41.00	202.00	400.00

CALL TOLL FREE 800-824-7888
(VISA, M.C., COD, ORDERS ONLY) OPERATOR 808
7 DAYS A WEEK

Creativity Unlimited

- CHECKS M.O., VISA, M.C.—ADD \$2.00 SHIP
- CA RESIDENTS ADD 6% SALES TAX
- SURCHARGE ON ORDERS SHIPPED OUTSIDE USA

P.O. BOX 3304
SARASOTA, FL 95070
(408) 252-4210

FREE CATALOG

Dealer Inquiries Invited

Circle 118 on inquiry card.

5 1/4" DISK DRIVES

TANDON

- ★ **TIM 100-1**
Single Sided, 40 TRK,
Single Or Double Density **\$17900**
Free Shipping
- ★ **TM 100-2**
Double Sided, 40 TRK/Side
Single Or Double Density **\$24900**
Free Shipping
- CDC**
- ★ **9409**
Double Sided, 40 TRK/Side
Single Or Double Density **\$24900**
Free Shipping

Order Toll Free

1-800-531-5475 (Outside Of Texas)
(512) 250-1523 (In Texas)

"If We Can't Ship The Next Working Day,
We Won't Take The Order."

MasterCard ★ VISA ★ Check
Texas Residents Add 5% Sales Tax.

CompuAdd Corp.

13010 Research Blvd., Suite 101
Austin, Texas 78750

Circle 84 on inquiry card.

TRUE 16 BIT PROCESSING



Z8001 Microprocessor (upgradable to Z8003)

- 2 Kx16 Eprom with Monitor Program (E/Rom optional)
- 16 Vectored Interrupts
- Full IEEE- 696 (S100) Compliance
- All Z8001 Features available
- Battery backup time of day clock
- Requires RAM capable of word transfers
- CP/M8000 Coming Soon
- Model M8000 CPU Board \$425⁰⁰
- Model M8000 EE with E/Rom \$500⁰⁰
- Memory Management Companion Card Available 3rd Quarter 1983.
- *6 month limited warranty

NEW!!
2 Serial / 2 Parallel I/O Card

- 2 Async serial ports
- 1 Centronics parallel port
- 1 General purpose parallel port
- 3 16 bit counter/timers
- Uses Zilog 8531/8536

Introductory Price \$225⁰⁰

To Order: Call 1-800-821-8858, in NM, 1-505-523-0975 or write:
MICRO SOLUTIONS INC.
Suite 191 B — 1608 El Paseo Rd. — Las Cruces, NM 88001
Include Ch., M.O. or use MasterCard or Visa. NM res. add 4.5% tax.

Circle 264 on inquiry card.

NEW REPLACEMENT
RIBBON CARTRIDGES

EPSON MX 70-80 \$4.75 ea.
MX 100 10.75 ea.

Please add \$.75 ea. shipping/handling.

WE HANDLE MOST POPULAR CARTRIDGES.
SEND FOR PRICE LIST

LABELS
\$12.00/5000

STOCK #10350-1 15/16" x 3 1/2" x 1 wide.
White—pressure sensitive—pin feed—
4 1/4" carrier, packed 5000 per box.
Add \$2.50 per box handling/shipping.
COMPLETE LINE OF OTHER LABELS
AVAILABLE. SEND FOR PRICE LIST

TERMS: MIN. ORDER \$12.00.
VISA & MC (add 4%), check or money order.
C.O.D.'s add \$2.00. CA residents add Sales Tax.

**S&W COMPUTER
SUPPLY CO.**

25422 TRABUCO RD. SUITE #200 A
EL TORO, CA. 92630 • (714) 768-0370

Circle 345 on inquiry card.

**NEW IBM PC
SOFTWARE**

Let Your Computer...
Write Its Own Programs!

FAST FILE, an applications
program generator, actually
develops finished, usable ap-
plication programs in a matter
of minutes.

Simple to operate, **FAST FILE**
can even be used by people
who know very little about
computers. No programming
knowledge required!

Do It In Style...
with **FAST FILE!**



DHD, Inc.
7777 Leesburg Pike
Falls Church, VA 22043
(703) 556-0950

Circle 135 on inquiry card.

COMPUTER SUPPLIES
FOR ALL MAKES & MODELS

DISKETTES

5 1/4
S/S S/D
MIN. ORDER 50 **\$180**

RIBBONS

NEC **\$688**
3500
(NON-FLIP CARTRIDGE)
EPSON **\$464**
MX70/MX80
EPSON **\$784**
MX100
MIN. ORDER 8

LABELS • CONTINUOUS FORMS

CALL TOLL FREE 1-800-248-2418

IN N.Y. STATE (212) 967-3433/1700

TERMS—VISA OR MC OR COD
DEALER INQUIRIES INVITED

WORLDWIDE COMPUTER SUPPLIES
159 MAIN ST., S.I., N.Y. 10307

Circle 425 on inquiry card.

**PROGRAMMABLE
COMMUNICATIONS
TRANSLATOR**

THE PCT-100 IS A CONFIGURABLE IN-LINE
RS-232 PROTOCOL AND DATA TRANSLATOR.
THE PCT-100 CAN PROVIDE:

- TERMINAL OR PRINTER EMULATION
- DEC OR IBM SYSTEM COMPATIBILITY
- MACRO-FUNCTION KEYS
- "TYPE-AHEAD" AND DATA BUFFERING
- BAUD RATE CONVERSION
- HANDSHAKE PROTOCOL TRANSLATION
(E.G. CTS/RTS, XON/XOFF)

THE PCT-100 IS CONFIGURED USING A
BUILT-IN COMMUNICATIONS TRANSLATION
LANGUAGE. PROGRAMS CAN BE EASILY
ENTERED & EDITED FROM ANY ASCII DEVICE.

PCT-100-PCB (PCB ONLY)... \$ 289
PCT-100-ASM (PCB W/ CASE)... \$ 339
PCT-512-MOD (POWER SUPPLY)... \$ 59



MSI



METHOD SYSTEMS INCORPORATED
19751 SOUTH LAKESHORE BOULEVARD
EUCLID, OHIO 44119
(216) 531-0404

Circle 258 on inquiry card.

WIREMASTER

Whip your wire wrap
and PC layout
problems with
WIREMASTER

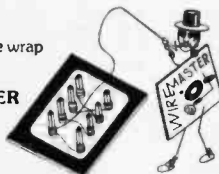

WIREMASTER is a software tool for design,
layout, and assembly of hardware. Your
schematic is fed to **WIREMASTER**, which
produces network maps, cross-references,
wire and parts lists, and debug checklists.
CHANGEMASTER keeps track of fixes and
updates. **PLOTBOARD** and **PRINTBOARD**
give pictures of the layout. Post-processors
for wirewrap machines available. Runs on
CP/M, MSDOS, UNIX, and VMS. \$195.

AFTERTHOUGHT ENGINEERING 7266 Court-
ney Dr., San Diego, CA 92111, (619) 279-2868.

Circle 15 on inquiry card.

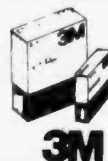

Scotch
DISKETTES

Call Toll-Free

1-800-328-DISC for prices and infor-
mation. Dealer inquiries invited.
C.O.D. and charge cards accepted.

All orders shipped from stock, within 24
hours. Call toll FREE



North Hills Corporation

3564 Rolling View Dr.

White Bear Lake, MN 55110

1-800-328-DISC

MN Call Collect 1-612-770-0485

PRINTER-STILTS™

● SOLVE YOUR PAPER STORAGE PROBLEMS ●
Elevate your Epson MX-70/80 or MX-100 Printer.
● Precision Machined — natural finish aluminum.
● Tilted to Facilitate Viewing — soft rubber feet.
● Easy to Install — no tools required.
MX-70/80 style fits IBM, TI and HP PC DOT PTRS.
Give style and send \$9.95 plus \$2.00 P and H.

DATATEK INC.
P.O. Box 5956 Dept. 400
Shreveport, LA. 71135
(318) 868-2241 or 868-0066 til 10 pm CST

Circle 133 on inquiry card.

CHIPS & DALE

THE INFLATION FIGHTERS!

- 4116 250ns 8/89.50 100+ 1.05 ea.
- 4116 200ns 8/10.00 100+ 1.05 ea.
- 4116 150ns 8/11.50 100+ 1.25 ea.
- 4116 120ns 8/14.50 100+ 1.50 ea.
- 4116 120ns 8/15.50 100+ 1.50 ea.
- 2114L 300ns 8/10.50
- 2114L 200ns 8/12.00
- *4164 200ns 8/4.65 ea.
- *4164 150ns 8/5.10 ea.
- *6116 150ns 8/4.00 ea.
- *6116 200ns 8/3.85 ea.
- *6116LP 150ns 8/4.75 ea.
- *1791 Disk Controller \$20.00
- 1777 Disk Controller \$17.50
- Z80A, Z80ACT, Z80A PIO \$3.00 ea.
- 8255 \$4.25
- 2716-1 5V 350ns 8/4.25 ea. 85.00 ea.
- 2716 5V 450ns 8/3.00 ea.
- *2732 5V 450ns 8/3.85 ea.
- *2532 5V 450ns 8/4.25 ea.
- *2764 5V 300ns 28 pin 8/9.00 ea.
- *2764 5V 24 pin CALL
- *2564 5V CALL
- *8087 CALL
- 68000 CALL

Allow up to 3 wks. for personal checks to clear. Please include
phone number. Prices subject to change without notice. Shipping &
Handling for Chips \$3.50, FOB Bellevue, WA. for all else. Wash.
residents add 6.5% Sales Tax.

CHIPS & DALE 1-206-451-9770
10655 N.E. 4th St., Suite 400
Bellevue, WA 98004

Circle 68 on inquiry card.

**Bargain
Boards™**

Best prices around on



boards.

28% OFF

Include \$6.00 per board for shipping and handling.

6331 Fairmount Ave. #701
El Cerrito, Ca. 94530
(415) 524-8352

CompuPro is a registered trademark of Goodson Electronics.

Now You Can Afford Another 64K...

Especially when it's less than
a half cent per bit!

COEX 64K S-100 CMOS STATIC RAM BOARD

Specifications

- Fully Static Operation
- Supports S-100 IEEE-696 Standards
- Uses Popular 2716 Pinout Type static RAMS's
- Board Access Time Under 200ns
- 150ns RAMS Standard
- No Wait States Needed at 6.000MHz
- High Quality FR-4 Type PC Board
- All Data, Status and Address Lines Fully Buffered
- Switch Selectable Phantom Line
- Gold Plated Contact Fingers for Low Contact Resistance and Long Life
- Switch Selectable Extended Address Lines for Up To 16 M-bytes
- Extreme Low Power Dissipation (<500mA Typical)
- Top 8K May Be Switched Disabled and/or Interchangeable with 2716 Type EPROM's

only \$299⁰⁰ Assembled & Tested

FOR YOUR APPLE IIe

COEX 64K Memory with built-in 80 Column x 24 Lines Upper and Lower Case. Fully compatible with all Apple IIe Software. Uses Auxillary Slot 0. Gold edge fingers. Jumper Set-up for extended high resolution. Full 90 day warranty.

only \$149⁰⁰ Assembled & tested

"Have You Kissed Your Computer Lately?"

Components Express, Inc.

1380 E. Edinger • Santa Ana, Calif. 92705 • 714/558-3972

TXW 910-595-1565 • ADVACON SNA • International Orders Welcome

Terms of Sale: Cash, Checks, Credit Cards, M.O., C.O.D. FOB Santa Ana. Calif. residents add 6% sales tax.

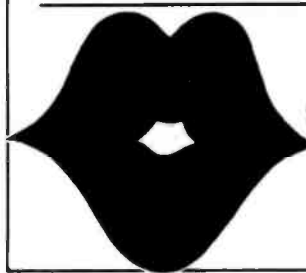

YOU'RE GONNA LOVE THESE ROCK BOTTOM PRICES!

MONITORS

ANDEK COLOR I PLUS	319.95
ANDEK VIDEO 300 (GREEN)	139.95
ANDEK VIDEO 300 (AMBER)	159.95
ANDEK VIDEO 310 (GREEN)	169.95
ANDEK VIDEO 310 (AMBER)	164.95
ANDEK COLOR 111	619.95
ANDEK COLOR 111	369.95
BMC 13" RGB COLOR - IBM	629.95
CMR 13" COLOR W/SOUND	294.95
COMREX 12" HI-RES AMBER	149.95
NEC 12" GREEN SCREEN	151.95
NEC 12" FCGO GREEN	109.95
NEC 12" LO-RES COLOR	299.95
PRINCETON GRAPHICS HK-12	199.95
TAXAN 12" GREEN	114.95
TAXAN 12" AMBER	119.95
ZENITH 12" GREEN	94.95
USI 9" AMBER MONITOR	129.95
USI 12" AMBER MONITOR	149.95

MODEMS

ANCHOR MARK I (RS-232)	79.95
ANCHOR MARK VII (RS-232)	109.95
NOVATION 3-CAT	164.95
NOVATION 212 AUTO CAT	579.95
SMARTCAT 212 (1200 BAUD)	429.95
SMARTMODM 300 BAUD	194.95
SMARTMODM 1200 BAUD	499.95
SMARTMODM 1200B - IBM	449.95

PRINTERS

COMDEX CW-1 DAISY WHEEL	729.95
DIABLO 630R155	1784.95
EPSON FX-80 W/TRACTOR	LOW!!
EPSON RX-80	LOW!!
EPSON FX-100 F/T	LOW!!
GEMINI 10	LOW!!
GEMINI 10X	LOW!!
GEMINI 15	LOW!!
GEMINI STX-80	LOW!!
GEMINI BANANA PRINTER	189.95
JUKI 6100 PRINTER (P)	549.95
MANHESMANN TALLY MT160L	779.95
MANHESMANN TALLY MT1602	1289.95
MANHESMANN TALLY MT1802	1499.95
NEC 3550 SP/W/WRITER-IBM	1754.95
NEC 8023 PRINTER	459.95
OKIDATA 82A W/GRAPHICS	449.95
OKIDATA 81A W/GRAPHICS	699.95
OKIDATA 84P	1049.95
OKIDATA 84S	1129.95
OKIDATA 92	494.95
OKIDATA 93P	929.95
OKIDATA 93S	994.95
OLYMPIA TYPEWRITER/PRINT	819.95
PRINTMASTER (DAISY)	1549.95
PROWRITER II PRINTER	344.95
PROWRITER II PRINTER	699.95
C ITOH COLOR PRINT/PILOT	499.95
C ITOH 8600P	979.95
SMITH CORONA TP-1	699.95
STARWRITER DAISY WHEEL	1099.95
TRANSTAR 315 COLOR	449.95
TRANSTAR 130 18CPS	729.95
TRANSTAR 140 40CPS	1229.95
EPSON SERIAL (RS-232)	134.95
GRAFITTY CARD	84.95
GRAPPLER +	119.95
MICRODUPPER II 16K	194.95
PKASO INTERFACE	129.95
WIZARD 8PC 16K	129.95
WIZARD SOB 16K	179.95

OTHER PRINTERS AVAILABLE

COMPUTERS

COMMODORE 64	239.95
COMMODORE 1541 DRIVE	219.95
ATARI 600XL	SCALL
ATARI 800XL	SCALL
ATARI 800	399.95-5100-8299.95
ATARI 1200	514.95-8100-8414.95
ATARI 1400XL	SCALL
ATARI 1150KLD	SCALL
IBM PC & XT	LOW!!
COLUMBIA VP PORTABLE	2249.95
COLUMBIA COMPLETE SYS.	2649.95
IBM-PC COMPATIBLE SYSTEM	128K, 2-DS/DD DRIVES, KEYBOARD AND COMPLETE SOFTWARE PACKAGE
CORVUS CONCEPT MCB8000	54999
256K, 8" FLOPPY DRIVE	
COMPLETE SOFTWARE PACKAGE	
BI-DIRECTIONAL 8-1/2x11 SCREEN	
CORVUS CONCEPT 511K	58995
CORONA DESKTOP PC	LOW!!
IBM-PC COMPATIBLE SYSTEM	
128K 2-DS/DD DRIVES, KEYBOARD	
COMPLETE SOFTWARE PACKAGE	
CORONA PORTABLE PC	LOW!!
EAGLE II 64K SYSTEM	1649.95
EAGLE PC 128K SYSTEM	2249.95
KAYPRO II	1399.95
WITH COMPLETE SOFTWARE PACKAGE	
SANYO HBC-1000	1579.95
SANYO PBC-20	77.95
SANYO PBC-25	149.95
TEROX 820-11	2099.00
NEC APC-H01	2495.00
NEC APC-H02	2995.00
NEC APC-H03	3249.00
NEC APC-MP1	4995.00
NEC APC-MP2	5695.00

APPLE //e NOW AVAILABLE

SYSCON II	684.95
FRANKLIN ACE 1000 W/COLOR LOW!!	
FRANKLIN ACE 1200	LOW!!
ORANGE + TWO W/Z-80 CPU	LOW!!
SPECIAL SYSTEM PRICE 1499.95	
ORANGE + TWO, 2 DISK DRIVES, BUILT IN Z-80 CPU, SOFTWARE, 12" GREEN MONITOR & VIDEO COMPATIBLE 80 COLUMN CARD.	
EASY-80 80 COL. VIDEO CARD FULLY VIDEO COMPATIBLE	
WORKS WITH WORDSTAR, dBASE, SUPER-TEXT-PRO, BASIC, C/P/M, PASCAL. SPECIAL INTRO PRICE	
	\$99.95
4TH DIMENSION DRIVE+CTRL	289.95
4TH DIMENSION DRIVE-ONLY	199.95
HAYES MICROMODEM II	259.95
KENNINGTON SYSTEM SAVER	64.95
RANA ELITE I W/CTRL-CARD	359.95
RANA ELITE II W/CTRL	509.95
RANA ELITE III W/CTRL	649.95
SOFTCARD (Z-80 CARD)	234.95
MICRO-SCI A2 W/CTRL-CARD	319.95
WE CARRY A FULL LINE OF HARDWARE AND SOFTWARE FOR THE APPLE	
DISKETTES	
ELEPHANT DISKETTES SS/DD	16.95
ELEPHANT DISKETTES SS/DD	19.95
ELEPHANT DISKETTES DS/DD	25.95

SOFTWARE

APPLE //	
ASCII EXPRESS PRO	89.95
BPI GENERAL ACCOUNTING	294.95
DATASAT (REQ Z-80)	194.95
DBASE II (REQ. Z-80)	449.95
INFOSTAR (REQ Z-80)	319.95
REPORTSTAR (REQ Z-80)	239.95
SENSIBLE SPELL '85	84.95
SPELLSTAR (REQ Z-80)	164.95
SUPERCALC (REQ Z-80)	189.95
SUPER-TEXT PRO 40/80	69.95
VISICALC 3.3	174.95
WORDSTAR W/APPLICARD	124.95
IBM	
LOTUS 1-2-3	LOW!!
BPI PERSONAL ACCOUNTING	149.95
QUADLINK APPLE EMULATOR	489.95
QUICK CODE (MS-DOS)	209.95
PIE WRITER	139.95
SMARTCOM II	89.95
BASIC COMPILER	279.95
MICROSOFT MOUSE	134.95
PEACHTEXT 5000 SER.9	259.95
SUPERCALC II	209.95
VISICALC 256K	179.95
COMMODORE 64	
CARDCO PARALLEL INTERFACE	64.95
CHDPLIFTER	34.95
COCC	37.95
COMMODORE RS-232 I/F	44.95
DATAXO 280 VIDEOPAK	224.95
JUMP MAN	27.95
GRIDDRIVER	27.95
PHARO'S CURSE	24.95
ROUNDABOUT	21.95
REGROW	27.95
HOWETEM	37.95
MYOFTM	27.95

TERMS: WE ACCEPT AMERICAN EXPRESS. NO EXTRA CHARGE FOR VISA/MASTERCARD, CASHIER'S CHECK, PERSONAL CHECK (ALLOW 2 WEEKS TO CLEAR). SHIPPING & HANDLING: \$4 (\$5 MIN); APC FPO ALASKA HAWAII & MONITORS \$4 (\$10 MIN); FOREIGN ORDERS 15% (\$15 MIN). ALL ITEMS ARE NEW WITH MANUFACTURER'S WARRANTY. PRICES ARE SUBJECT TO AVAILABILITY & CHANGE WITHOUT NOTICE. PURCHASE ORDER MUST INCLUDE CHECK. CALIFORNIA RESIDENTS ADD 6% SALES TAX. SEND \$1 (GOOD TOWARD FIRST PURCHASE) FOR NEW FALL CATALOG. 8-1-83

Call us... we can help! 1-800-222-2602

Circle 28 on inquiry card.

Technical Assistance, Order Status & California Calls (619) 765-0239

APPLE COUNTRY, LTD.

P. O. BOX 1099
2602 WASHINGTON
JULIAN, CALIF. 92036



**DiscMaster 1000
Videodisc Interface**

- Enables computer control of laser videodisc players
- Works with any mainframe, mini, or microcomputer
- Standard RS-232C serial interface
- No modification required to player or computer
- Interactive playback for training, marketing, exhibition, and data retrieval
- All cables and connectors included
- Price: \$395

New Media Graphics Corporation
139 Main Street
Cambridge, MA 02142
617-547-4344

Circle 287 on Inquiry card.

STOP LOSING MONEY ON TIMESHARE SERVICES!

LOGICSIM

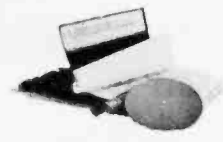

CP/M based professional logic simulator

- * For engineering work stations
- * For gate-array, custom and all other IC designers
- * For digital system engineers

Nine logic states, ability to simulate TTL/NMOS/CMOS/PMOS logic, ROM's and RAM's, three-state and transfer gates, wired-OR nodes, propagation delays, spike and race analysis, expandable pin-number based TTL macro library plus numerous other features make LOGICSIM comparable to industry standard simulators.

Try it now. Send us a \$30 check for LOGICSIM demo copy and User's Manual.

Please specify 8" IBM 3740/ 5" APPLE II (13/16 sector), CP/M based 56K to 64K systems (APPLE's with CP/M cards). Introductory price \$276.

For more information, call (408) 578-8096. Or write:
E/Z ASSOCIATES, 5589 Starcrest Dr., San Jose, CA 95123

APPLE, CP/M, LOGICSIM are trademarks of Apple Computer, Digital Research and E/Z ASSOCIATES

Circle 154 on Inquiry card.



flexible disks

Call Free (800)235-4137
for prices and information.
Dealer inquiries invited.
C.O.D. and charge cards
accepted.



VISA

PACIFIC EXCHANGES
100 Foothill Blvd
San Luis Obispo, CA
93401 (In Cal. call
(805) 543-1037)

Circle 299 on Inquiry card.

**1st ANNIVERSARY
CHRISTMAS SPECIAL**
★ DRAWING FOR A FREE ★



**GARDEN OF EDEN
COMPUTERS**
13147 Cedar Street
Westminster, CA 92683
MAIL ORDERS ONLY
714-894-9528
24 Hours - 7 Days
Hayes Smartmodem
1200 BD RS 232 **\$479.00**

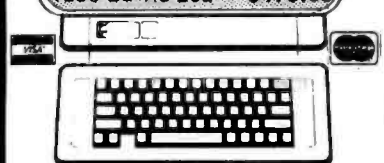

FOR DETAILS & OUR FREE PRICE LIST
CALL, WRITE OR USE R/S*

Circle 178 on Inquiry card.

IBM PC, APPLE, etc. . .

SHARING AND SWITCHING PROBLEMS?
GILTRONIX HAS THE SOLUTION!



Any CPU

Printer 1: Dot Matrix
Printer 2: Letter Quality
Modem or Other Peripheral

MANUAL UNITS: 2-6 Ports, Selecto-Switch
OR
AUTOMATIC UNITS: 2-7 Ports, Auto-Switch

Serial (RS 232)/Parallel (Centronics)

LOW COST ADD-ONS FROM THE MAIN MANUFACTURER



3780 Fabian Way, Palo Alto, CA 94303
(415) 493-1300

Circle 181 on Inquiry card.

5 Year Warranty

**SAVE 50% ON
Verbatim Datalife
Diskettes**

DEALER INQUIRIES INVITED

5 1/4"	Specify Soft 10 or 16 Sectors	prices/10
MD525	1 side/dbl dens.	\$24.90
MD550	2 sides/dbl dens.	35.00
MD577	1 side/quad 96tpi	33.75
MD557	2 sides/quad 96tpi	44.50
8"	Specify Soft or 32 Sector	
FD34-9000	1 side/sgl dens.	30.00
FD34-8000	1 side/dbl dens.	33.00
DD34-4001	2 sides/dbl dens.	41.00

Checks-VISA-MC-C.O.D./Add \$2 Shipping
Call or write for our discount catalog.

LYBEN COMPUTER SYSTEMS
27204 Harper Ave., St. Clair Shores, MI 48081
Phone: (313) 777-7780

**DATALIFE • THE NAME IS THE PROMISE
THE WARRANTY IS THE PROOF**

Circle 243 on Inquiry card.

**Verbatim®
Diskettes**



Top-quality Verbatim® Diskettes from **Tech•Data**, your complete supply and peripheral wholesaler. **Dealers only.**

Call Toll Free
1-800-237-8931.
In Florida, call
813-577-2794.



Tech•Data Corporation
3251 Tech Drive North
St. Petersburg, FL 33702

Circle 383 on Inquiry card.

MICROCONTROL!

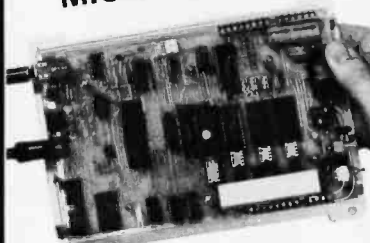

CONTROL THE REAL WORLD
LIKE NEVER BEFORE!
AND DO IT FOR AS LITTLE AS \$299*

THE NEW RBE SYSTEM • Z800 Z8071 MCU • 16 K MEMORY
FRIENDLY BASIC INTERPRETER • PARALLEL AND SERIAL PORTS •
110V AC POWER CONTROL PORTS • A/D & SENSOR INPUT PORTS •
BATTERY RAM AND MUCH MORE • WRITE FOR INFO.

*BASE PRICE

HHS MICROCONTROLLERS
5876 OLD STATE
EDINBORO, PA 15412
(610) 736-4338

Circle 190 on Inquiry card.

RTL

**Relocatable
Threaded
Language**

\$150

RTL is a new language which retains the speed and extensibility of Forth but adds many additional advantages as a result of its more structured dictionary. Names, code, and variables are all stored in separate areas for easy generation of headerless, romable code. All code is relocatable. RTL supports local variables, multitasking, redirected I/O, and even allows definitions to be changed retroactively. All source code is included. Versions are currently available or under development for 68000, 6809, 8080, 280, 8086, 8088, and 6502.

RTL Programming Aids
10844 Deerwood SE
Lowell, MI 49331
(616) 897-5672

Circle 344 on Inquiry card.

MICROMAIL™



IBM PC-COMplete SYSTEM— SPECIAL PRICE

PC System includes 64K IBM PC with 320 KB Floppy Disk Drive, Controller, Color Graphics Card, Monitor
\$2490

DISK DRIVES FOR IBM PC

Tandon 100-2	\$240
Shugart 455-2	\$245
Teac 55-B	\$255

MONITORS

NEC, DYNAX AMDEK **CALL**

PRINCETON GRAPHICS SYSTEMS

Hi-Res Color **\$490**

PRINTERS

C-ITOH

GX-100	\$240	1550	\$690
8510	\$460	F-10	\$1290
F-10			\$1690

OKIDATA

82A	\$440	84A	\$975
83A	\$690	92A	\$575
93A			\$970

BROTHER

HR-1	\$750
HR-15	\$570

SMITH CORONA

TP-1	\$520
------------	-------

STAR MICRONICS

Gemini 10	\$370
Gemini 15	\$540

NEC

SPINWRITER

7710-1	\$1950	3510	\$1350
7715-1	\$2100	3515	\$1350
7720-1	\$2400	3530	\$1550
7725-1	\$2400	3550	\$1850
7730-1	\$1950	PC8023A	\$450

HARD DISKS FOR APPLE AND IBM DAVONG

5 MB	\$1450
10 MB	\$1650
15 MB	\$2250

MEMORY BOARDS

TAVA CORP.

TRUMPCARD 1

256K Ram	\$350
----------------	-------

TRUMPCARD 2

512K RAM	\$550
----------------	-------

AST

IO Plus. Five function Card **\$199**

Combo Plus 4 function card. Fully pop. 256K. **\$490**

Mega Plus. Fully pop. 512K..... **\$990**

QUADRAM

Quad Card. Fully pop. 256K **\$500**

BIG BLUE **\$470**

HERCULES Graphics Card **\$490**

MAYNARD SANDSTAR SERIES

FDC 5 1/4 & 8" **\$220**

Multifunction Card **\$90**

Memory Card **\$180**

Ad-On Memory Module **\$90**

Parallel Port Module **\$70**

Serial Port Module **\$90**

Clock Calendar Module **\$70**

Game Adapter Module **\$50**

DEC RAINBOW 100

Complete system 64K PC, Keyboard, Two Floppy Drives

DS/DD, Monochrome Monitor **\$2990**

APPLE II+

Compatible Computer with 48K Disk Drive, Controller,

and Monitor **\$990**

DISK DRIVE FOR APPLE

Slimline, or Standard..... **\$250**

PERSONAL ACCOUNTANT Software for your

Apple IIe and Apple II+. **\$190**

APPLE IIe

Computer System, Controller, Two Disk Drives,

Monitor **\$1890**



MICROMAIL

631 E. First St., Tustin, CA 92680

PRICES AND AVAILABILITY SUBJECT TO CHANGE WITHOUT NOTICE

(714) 838-9100

APPLE is a trademark of Apple Computers, Inc.
 IBM is a trademark of IBM Corp.

TeleVideo DEALERS

- Fast Dump/Restore over 600k per disk \$60
- Type Ahead with Print Screen 84k Byte Type Buffer \$60
- 3270 & 2780/3780 Bisync Communications from Phone 1 & Batech \$700 & \$300
- TurboDOS for TELEVIDEO Start at \$225
- BIOS & Formatting for 802H use all 20 MB \$150
- 8" Disk Drive for 802 Drive Hardware & Software \$1,100
- RM Cobol for TurboDOS Full System \$525
Run Time \$175
- Standby Power System 200VA-400VA-800VA As low as \$363

CP/M® is registered trademark of Digital Research, Inc.
TurboDOS is a registered trademark of Software 2000, Inc.

PLUS OTHER GOOD TELEVIDEO STUFF!

COGITATE, Inc.

SPECIALISTS IN UNIQUE TELEVIDEO SOFTWARE
24000 Telegraph Road, Southfield, MI 48034
(313) 352-2345

VISA/MASTER CARD Accepted

Circle 74 on inquiry card.

FAST Factory Floppy Disc Drive Repair

Specialists in the repair of:

Shugart
Tandon
PerSci

PERSci, Inc.



12624 Daphne Avenue
Hawthorne, CA 90250
(213) 777-7536
TWX 910-321-4448

Circle 310 on inquiry card.

Electronic Circuit Analysis

- AC and DC analysis
- Very fast, optimized machine language
- Infinite circuits on multiple passes
- Worst case, sensitivity analysis
- Sweep component values
- 64 Nodes, 127 branches
- Compare circuits
- Log or linear sweep
- Full file handling
- Full editing, error trapping
- Frequency response, magnitude and phase
- Complete manual with examples
- CP/M \$150.00
- Now available for MSDOS (IBM PC) \$150.00

Tatum Labs

P.O. Box 722

Hawleyville, CT 06440

(203) 426-2184

Circle 379 on inquiry card.

\$73.80*

Single Board Computer

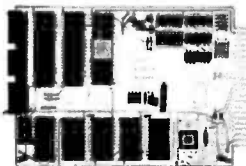

6800 MPU, serial I/O, parallel I/O, RAM, EROM, 44-pin 4 1/2" x 6 1/2" PCB

EXPANSION MODULES

RAM, ROM, CMOS RAM/battery, analog I/O, serial I/O, parallel I/O, counter/timer, 488 GPIB, EROM programmer, power fail detect/power on reset



Wintek Corp.
1801 South Street
Lafayette, IN 47904
317-742-8428

Circle 423 on inquiry card.

New Offer

Butcher Block

OAK DESK \$225.00*

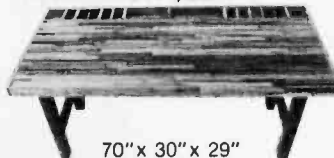

70" x 30" x 29"

Give yourself the workspace you need!

Large solid hardwood work station has ample space for computer, peripherals, storage, and your notes. Shipped knocked down and unfinished; assembles with lag screws. Wt: 122 lbs.

*We will pay freight up to \$40.00 on orders postmarked before Sept. 1, 1983, otherwise shipped motor freight collect. Satisfaction guaranteed. Send check or money order to:

A.M. LOVEMAN LUMBER & BOX CO.
P.O. Box 90123, Nashville, TN 37209

Catalog \$2.00. Dealer Inquiries Invited.

Circle 194 on inquiry card.

Like-new products



For free catalog,
phone toll-free (800) 225-1008
In Massachusetts (617) 938-0900

Genstar REI Sales Company

6307 DeSoto Ave., Ste. J / Woodland Hills, CA 91367

Circle 179 on inquiry card.

SIBEC 51

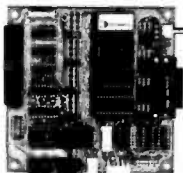

8051-Based Single-Board Computer with Monitor/Debugger

- Versatile - 4 28-pin byte-wide sockets; monitor will program EEPROMs.
- Affordable - just \$335
- Perfect for System Development and Educational Applications



Binary Technology

P.O. BOX A-59 • MANOVER, NH 03755 • 603 643-2881



Circle 50 on inquiry card.

Dysan CORPORATION

Solve your disc problems, buy 100% surface tested Dysan diskettes. All orders shipped from stock, within 24 hours. Call toll FREE (800) 235-4137 for prices and information. Visa and Master Card accepted.



PACIFIC
EXCHANGES
100 Foothill Blvd.
San Luis Obispo, CA
93401 (In Cal. call
(805) 543-1037.)

Circle 299 on inquiry card.

www.americanradiohistory.com

WHOLESALE

BRAND NAME DRIVES & DISKETTES

DIRECT TO THE PUBLIC

DRIVES:

TANDON }
TEAC }
QUME }
FOURTH DIMENSION }
MICRO-SCI }
RANA }

DISKETTES:

Slim-Line }
or }
Regular }
MAXELL }
VERBATIM }
ZIMAG }

Prices Too Low
To Publish!

CONTACT:

RM DISTRIBUTORS, INC.
P.O. Box 39235
DENVER, CO 80239
TEL. 303-371-2432

Circle 342 on inquiry card.

Our Prices Will Get Your Attention. Our Service Will Keep It. Our Customers Agree.

a word from
a customer ...

7 APR 83

Dear AEI:

I ordered a printer from you on your toll-free line. The salesman, Mario Boon, was very helpful and knowledgeable. When he couldn't answer a question he took my number and called me back after checking with his technician. The order was placed and six days later the printer arrived. The factory box had been opened and it was obvious that AEI tested the unit before shipping as your advertising claimed. . . .

I thought you might enjoy knowing that the service you offer is much appreciated. AEI will get first crack at all future computer purchases.

Sincerely,

M. Boon

GUARANTEE

- PROVEN PRODUCTS • SYSTEM DESIGN HELP
- BENCH TESTING AND CONFIGURING
- TECHNICAL SUPPORT STAFF • SERVICE AFTER SALE:

800-854-7635 TECHNICAL SERVICE SUPPORT

We will pay the freight — both ways — for repair on verified returns within 30 days of sale.

TERMS AND CONDITIONS

Prices change daily. Call for current pricing & availability. Prices based on prepaid cash orders. We accept: cashiers checks, money orders, bank wires, or personal checks (10 days to clear). C.O.D. — standard charges plus 2% handling for orders outside California. MasterCard & VISA — 5% handling. California residents add state & local sales tax.

SPECIAL!
Zenith
Green Screen

\$9500

We carry: NORTH STAR • ZENITH • MORROW • EAGLE • COLUMBIA • TELEVIDEO • C-ITOH • TOSHIBA • DIABLO • SILVER REED • NEC 3500 & 7700 SERIES • STAR MICRONICS • MANNESMANN TALLY • FRANKLIN ACCESSORY PRODUCTS • AND MORE...

SOFTWARE



FOR FOLLOWING SYSTEMS:

Altos CP/M 5.1/4" • Apple DOS & CP/M • Atari • CP/M-86 Display Writer • Cromemco CP/M 5.1/4" • DEC VT-180 CP/M 5.1/4" • Eagle CP/M 5.1/4" • Heath Z-90 CP/M 5.1/4" • IBM PC CP/M 86 • IBM PC DOS • NEC CP/M 5.1/4" • Northstar Advantage & Horizon CP/M 5.1/4" • Osborne CP/M 5.1/4" • Otrona CP/M 5.1/4" • Software for 8086 Computers • Standard CP/M 8" • TRS-80 Cassette Models I & III • TRS-80 Diskette Models I & III • TRS-80 Model II CP/M • Televideo CP/M 5.1/4" • Vic 20 • Xerox 820 CP/M 5.1/4" • **Call for Current Pricing**

HARDWARE



PRODUCTS AND PRICING EXAMPLES:

TELEVIDEO SYSTEMS: TS-802 Single User Computer \$2632 • TS-806 Multiuser System \$5050 • 910 Plus Terminal \$573 • 950 Terminal \$921 • **ZENITH:** ZTX-1 Auto Dial Personal Terminal \$341 • Z-29 Terminal \$683 • **OKIDATA:** OK-82A with Tractor Feed \$486 • Okigraph I for 82A & 83A \$45 • 2K Buffer/Serial BD \$119 • OK Microline 83A \$713 • **MANNESMANN TALLY:** MT1600's Serial & Parallel \$1441 • **NOVATION:** J-CAT Modem \$110 • **ORANGE MICRO:** Grappler \$125 • **Plus Much More ...!**

These prices prepared 6/83

Prices change daily —

call for current pricing
and shipping charges.



CALL US TOLL-FREE:

800-854-7635

IN CALIFORNIA CALL:

(619) 562-7571

AEI

AUTOMATED EQUIPMENT, INC.

8775 Olive Lane, Suites I & J • Santee, CA 92071



**RS232C Computer compatible
Paper Tape Transmitter/Model 612**

Stops and starts on character at all speeds, uses manual control or X-on, X-off 90-260 volt, 50-60 Hz power. 50-9600 baud, up to 150 char/sec synchronous or asynchronous; gated internal or external clock, RS 232C, current loop or parallel output, reads 5-8 level tape, 7-11 frames per character, even or odd parity. Desk top or rack mount.
Addmaster Corporation, 415 Junipero Serra Drive, San Gabriel, CA 91776, (213) 285-1121, Telex 674770 Addmaster SGAB

Circle 7 on Inquiry card.

**DISKETTES
3M Scotch BRAND**

**AT SUPER LOW PRICES
WE WILL SHIP YOUR
ORDER WITHIN 24 HOURS
AND WE PAY THE
SHIPPING CHARGES**



DEALER INQUIRIES INVITED



**CALL TOLL FREE
800 922-8193**

**IN CALIFORNIA
800 468-1068**



**Tayco Business Forms
Computer Supplies
Post Office Box 605
Newbury Park, CA 91320**

Circle 382 on Inquiry card.

NEW ELIZA FORMATS!

AT LAST! A FULL IMPLEMENTATION of the original ELIZA program is now available to run on your microcomputer!

Created @ MIT in 1966, ELIZA has become the world's most celebrated artificial intelligence demonstration program. ELIZA is a non-directive psychotherapist who analyzes each statement as you type it in and then responds with her own comment or question—and her remarks are often amazingly appropriate!

Designed to run on a large mainframe, ELIZA has never before been available to personal computer users except in greatly stripped down versions lacking the sophistication which made the original program so fascinating.

Now, our new microcomputer version possessing the FULL power and range of expression of the original is being offered at the introductory price of only \$25. And if you want to find out how she does it for yourself, do more! We will include the complete SOURCE PROGRAM for only \$20 additional!

Order your copy of ELIZA today and you'll never again wonder how to respond when you hear someone say, "Okay, let's see what this computer of yours can actually do!"

ELIZA IS AVAILABLE IN THE FOLLOWING FORMATS:

- 5 1/4 inch disk for the 48K Apple II, II Plus, IIe or III \$25 for Protected Version—\$45 for AppleSoft Source Version
- 5 1/4 inch disk for the 64K IBM Personal Computer \$25 for Protected Version—\$45 for IBM Disk BASIC Source Version
- Tape Cassette for the Commodore 64 \$25 for Protected Version—\$45 for C-64 BASIC Source Version
- Standard 8 inch single density disk for all CP/M based computers \$25 for ELIZA.COM—\$45 with Microsoft BASIC-80 Source
- 5 1/4 inch disk for most CP/M based computers (specify computer) \$25 for ELIZA.COM—\$45 with Microsoft BASIC-80 Source

Please add \$2.00 shipping and handling to all orders (California residents please add 6% sales tax)

ARTIFICIAL INTELLIGENCE RESEARCH GROUP

921 North La Jolla Avenue, Dept. B
Los Angeles, CA 90046
12131 656-7368 12131 654-2214
MC, VISA and checks accepted



Circle 33 on Inquiry card.

maxell

Floppy Discs

**CALL NOW—TOLL FREE
1-800-328-DISC**

Dealer inquiries invited. C.O.D.'s and charge cards accepted.

**All orders shipped from stock,
within 24 hours. Call toll FREE.**



North Hills Corporation

3564 Rolling View Dr.
White Bear Lake, MN 55110
1-800-328-DISC

MN Call Collect 1-612-770-0485

Circle 405 on Inquiry card.

SUPER-FAST!

Z80

Relocating Macro

ASSEMBLER

\$169.95

Directly generates COM, HEX, or REL files. Flexible REL format allows external bytes and words with complete math operations on them (Microsoft format optional). Features Zilog mnemonics with nested macros, conditionals and include files. Unique one-pass design generates compact intermediate code which is then processed to resolve forward references, yielding tremendous time savings. Complete listing, symbol table and cross-reference output may be sent to any device. The perfect tool for assembly language programming. Linker included. Manual only — \$30. For Z80 CP/M and TRS-80.

S L R Systems

1622 NORTH MAIN ST. • BUTLER, PA 16001 • (412) 282-0864

Shipping \$3 U.S. others \$7 PA * 8% Check MO VISA, M C C O D
Most formats available. Dealer and OEM inquiries invited.
Z80, CP/M, TRS-80 TMs of Zilog, Digital Research, Tandy Corp.

Circle 357 on Inquiry card.

**ANALOG ↔ DIGITAL
DIGITAL ↔ ANALOG**

CONVERSION MODULES

**SOFTWARE
GAIN CONTROL**

high accuracy	programmable gain	16-channel	conversion to digital
amplifier	custom board test	5-100	1 to 15 kHz
conversion time	mixable high and low inputs	gain	2 to 15 kHz
from 1 to 1024	12 bit	sample and hold capability	12-bit
8-channel differential	programmable gain instrumentation	amplifier	conversion time
high accuracy	programmable gain instrumentation	amplifier	conversion time
conversion time	12-bit	sample and hold amplifier	8-channel differential
high accuracy	programmable gain instrumentation	amplifier	conversion time
conversion time	12-bit	sample and hold amplifier	8-channel differential
high accuracy	programmable gain instrumentation	amplifier	conversion time
conversion time	12-bit	sample and hold amplifier	8-channel differential

For additional details about the AD-100-4 and other fine California Data Corporation 100% individually tested, high reliability products, circle the reader service card number below or for faster response write or call us.

CALIFORNIA DATA CORPORATION

3475 Old Conejo Road, Suite C-10
Newbury Park, CA 91320

(805) 498-3651

Circle 82 on Inquiry card.

uniforth

One of the finest implementations of the FORTH language. Field tested and reliable, UNIFORTH is available for the IBM, PC as well as most systems with 8" disks and the following processors:

8080	PDP-11
Z80	68000
8086/8	16032

As a task, UNIFORTH is compatible with and supports all features and file types of the CP/M, CDOS, MS-DOS and DEC operating systems. As an operating system, UNIFORTH will function "stand-alone" on most commercial microcomputers.

The FORTH-79 Standard language has been extended with over 500 new words that provide full-screen and line-oriented editors, array and string handling, enhanced disk and terminal I/O, and an excellent assembler. Detailed reference manuals supply complete documentation for programming and system operation. In an easy-to-understand, conversational style using numerous examples.

Optional features include an excellent floating-point package with all transcendental functions (logs, tangents, etc.), the MetaFORTH cross-compiler, printer plotting and CP/M file transfer utilities, astronomical and amateur radio applications, word processing, etc.

Compare these features with any other FORTH on the market:

- Speed and efficiency
- Ease of use
- Variety of options
- Documentation quality

You'll find UNIFORTH is superior.

Prices start at \$35. Call or write for our free brochure.

Unified Software Systems

P.O. Box 2644, New Carrollton, MD 20784, (301) 652-1295

Circle 405 on Inquiry card.

68000

CROSS ASSEMBLER

FOR CP/M-80 \$ 260

MOTOROLA SYNTAX MACROS

LINKAGE EDITOR CONDITIONALS

STRUCTURED WRITTEN IN C

Quelo (206) 784-8018
843 NW 54th mornings
Seattle, Wa. 98107 Dick Gurliss

CP/M is a trademark of Digital Research

Circle 333 on Inquiry card.

IBM® DISKETTES

5 1/4" Diskette 1D Single Side Double Density \$29⁹⁰	5 1/4" Diskette 2D Double Side Double Density \$39⁹⁰
---	---

Soft* Box of 10 Soft* Box of 10
* Add \$1.75 for Plastic Library Case
8" and other brands also available.

**COD ACCEPTED
DEALER INQUIRIES INVITED**



**CALL TOLL FREE
800-848-1101**

In N.Y.S. (716) 631-3925
BETSY BYTES Division
BB International, Inc.
P.O. Box 564
Buffalo, N.Y. 14221

TERMS: Prepaid orders receive free shipping within continental U.S.A. Add 3% (\$2.00 minimum) shipping and handling charge on all COD and credit card orders. N.Y. res. add 7% tax.

Circle 48 on Inquiry card.

FORMULA INTERNATIONAL INC.

12603 Crenshaw Blvd., Dept. B, Hawthorne, CA 90250

For information (213) 973-1921 • Orders Only (outside Calif.) (800) 672-8758

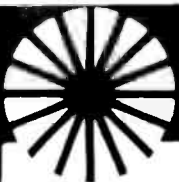

pinecom™

The Alternative! The Compatible! The Affordable! 64K Color Computer Kit!

Copyright Problem Free!

FEATURES:

- ★ Fully compatible with Apple® II +
- ★ Singleboard for easy assembly
- ★ Popular 6502 MPU for large amount of software
- ★ Game paddle connector on both sides of case
- ★ Upper/lower case
- ★ Built in 2-watt amplifier for realistic sound effect with volume control
- ★ 8 on board peripheral connectors for expansion
- ★ 14 key numeric key pad
- ★ 5-amp switching power supply
- ★ Auto repeat

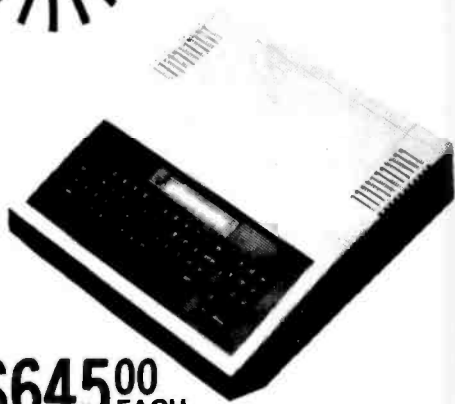

\$645⁰⁰ EACH

(please add 5% shipping and handling)
DEALERS INQUIRIES INVITED!

Easy to assemble! All components are clearly silk-screened on the high quality double-sided mother board. All integrated circuits, IC sockets, peripheral connectors, keyboard, switching power supply and the professional high impact plastic case are included.

*Pinecom is a trade mark of Pineapple Computer Products (HK) Ltd.

5 1/4" DISC DRIVE FROM QUENTIN RESEARCH INC.

100% Made in USA 100% Apple and Pincom Compatible
50% Faster Seeking Time Than Apple Disk II Drive!

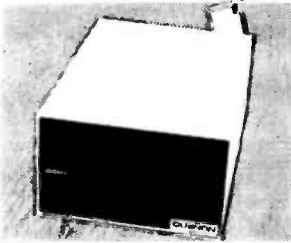

- 1 Year Full Warranty
- 40 Tracks
- One of the Most Quiet Drives
- Color and Shape same as the Disk II Drive

Disk Drive **\$285.00**

Controller Card **\$ 75.00**

Controller Card with 13 Sector, 16 Sector Auto Select **\$ 85.00**

The APPLE II LOOKALIKE COMPUTER CASE

Made with high impact plastic. Color and shape are compatible with the APPLE II



Model: APII
Keyboard not included with this price!

Special \$99.95

Available As Kit—Includes: Case, AP II Motherboard, 5A Power Supply, AP II Keyboard, Component Set.\$575.00/Kit

6502 CPU MOTHER BOARD

- 48K on board RAM (4116)
- 12K on board ROM (2716)
- Upper/lower case
- Composite-video output
- Apple II alternative
- Size: 14 1/4" x 8 1/2"

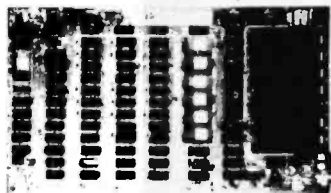

P.C. Board Only **\$99.00 ea.**

Complete Component Pack (No ROMs) **\$175.00**

GUARANTEED TO WORK! BUILD IT IN 2 HOURS!

Big Savings On Peripheral Cards

Buy them in kit form — All cards APPLE II and Pinecom compatible.

80 - Column card Kit	\$110.00	EPROM Programmer Card (for 2708, 2716, 2732 & 2764) with on board software Kit ..	69.95
80 - Column card Assembled	\$125.00	Same as Above Assembled	85.00
Smarterm II 80 col card w/softswitch	159.00	EPROM Blaster by Apparat, Inc. (for 2708, 2716 & 2732) with software on Disc.	119.00
Z-80A CP/M Card Kit	99.95	EPSON Printer Interface Card Assembled.	85.00
Z-80A CP/M Card Assembled	115.00	EPSON Printer Interface Card Kit	69.50
Z-Card with operating system	149.00	Wizard IPI Parallel Printer Card-Epson	85.00
16K RAM card - "Cableless" Kit	51.95	The Dispatcher Serial Printer Interface	120.00
16K RAM card - "Cableless" Assembled	59.00		

HEAVY DUTY SWITCHING POWER SUPPLY for Apple II, AP-II™ and Pinecom Computers

- +5V at 5.0 Amp
- +12V at 2.5 Amp
- 5V at 0.5 Amp
- 12V at 0.5 Amp



Model: THB-43H

Size and mounting holes are same as the ones used in the Apple II

\$135.00 ea.

APPLE II+ COMPATIBLE KEYBOARD

- LSI keyboard decoder
- Full ASCII code output
- Upper/lower case function
- N-key rollover function
- LED ON/OFF indicator



LKB-3600-N

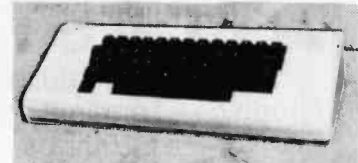

Keyboard Case

Keyboard Only **\$99.00 EA.** Plastic Case **\$35.00 EA.**



MICRO II CASE

Made with ABS Plastic • Same size as the Apple II, with Numeric Key-Pad and Upper/Lower Case • Keyboard included

\$250.00 ea.



Complete Kit Also Available

Includes: Micro II Case, AP II Motherboard, 5A Power Supply, Component Set ..\$625.00/Kit

SEND ONE DOLLAR FOR OUR DETAIL CATALOG

Shipping & Handling Charges Under \$50.00 Under \$50.00

Purchase	10%	5%
Purchase	15%	10%
Purchase	25%	20%

Minimum Order \$10.00/Calif. Residents add 6.5% Sales Tax. Phone Orders Accepted on VISA or MC ONLY. NO C.O.D.'s. Prices subject to change without notice.



STORE HOURS
MON-FRI-10-7
SAT-10-6

Inside California
Outside Calif. (Incl. Mexico & Canada)
Overseas

*Apple and Apple II are the trademark of APPLE COMPUTERS, INC.

Dealer inquiries, Circle 172 All others, Circle 173

EPSON® RIBBON CARTRIDGES



MX 70/80
\$5.25 EA.
\$60.00/box

MX 100
\$9.95 EA.
\$108.00/box.

EPSON®
MX 100-ZIP
PACK-IRELOAD!
\$6.50 EA
\$72.00/box.

PLUS OTHER MAJOR BRAND NAMES
AVAILABLE
DWIGHT COMPANY, INC.
15565 Northland Drive
Suite 804 West
Southfield, MI 48075
(313) 569-3218

Circle 152 on inquiry card.

PC/FORTH™

Complete FORTH program development systems for the IBM® Personal Computer. Packages include interpreter/compiler with virtual memory management, line editor, custom screen editor, assembler, decompiler, utilities, file and record access modules, and many demonstration programs. 150 page user manual. . . . \$100.00

Software floating point, Intel 8087 support, color graphics extensions, and target compiler available at additional cost.

Specify PC-DOS or CP/M-86®. One disk drive and 48 kbytes RAM required. Software supplied on 5¼ inch single sided soft sectored double density diskettes.

Laboratory Microsystems
4147 Beethoven Street
Los Angeles, CA 90066
(213) 306-7412

IBM is a registered trademark of International Business Machines Corp
CP/M is a registered trademark of Digital Research, Inc.

Circle 233 on inquiry card.

NEW!!

The Apple users group software library bonanza at truly affordable prices. For the first time enjoy your Apple to its fullest capacity using specially packed disks with over 80 outstanding programs each. Not available from any other source!

• Applesoft • 3.3 DOS

PROGRAMS \$1-EACH

APPLEWARE INC. offers
An extensive variety of interesting, useful and entertaining programs indispensable to the serious computerist including:

Business	Educational	Graphics
Games	Music	Science
Utilities	Data Base	Finance

Library disks 1, 2 & 3 are mixed categories and new disks 4 (Games), 5 (Utilities), 6 (Graphics) & 7 (Integer) at \$59.95 each. Why pay more?

Order direct from this ad and Save up to \$136. Buy disk library package 1, 2 & 3 and get a special bonus disk FREE — over 260 programs for \$179.95 + shipping. For best value, get all 8 disks for \$349, postage prepaid, for over 530 of our best programs at 65¢ each! Call now toll free: 1-800-327-8664
Florida: 1-305-987-8665
6400 Hayes St.
Hollywood, FL 33024



Circle 29 on inquiry card.

NEW! M-68000 SINGLE BOARD COMPUTER



FEATURES:
16 bit Motorola 68000 CPU operating at 10MHz, 20K bytes of on board fast static RAM, 16K bytes of on board EPROM space, 7 levels of prioritized auto vectored interrupts, 2 memory expansion buses (up to 256K), 2 serial communication ports (RS-232C), 16-bit bidirectional parallel port, 6800 peripheral accommodation bus, 516-bit counter/timers with vectored interrupts, on board real time clock, software compatible with Motorola MEX48613M board.

PRICE:
Bare board with documentation \$99.95
MEX48613M compatible monitor in 2744 EPROM's \$120.00
M68000 CPU & memory map PROM \$115.00
Shipping and handling (Domestic) \$3.00
(Foreign) \$15.00
CALIFORNIA RESIDENTS ADD 6% TAX

EMS Electronic Management Systems
P.O. BOX 16133 IRVINE, CA 92713-6135

714-553-0133

Circle 159 on inquiry card.

RL1* IS BY FAR THE BEST

RELATIONAL DATABASE MANAGEMENT SYSTEM FOR YOUR PC*

\$795.00 including Report Generator, etc.
Visa, Master Card, Check, COD

JF ELECTRIC CO.
PO BOX 37236
OAK PARK MI 48237
313 545 0335

*TRADEMARK
PC IS OF IBM
RL1 IS OF ABV

FOR PC*
YOUR PC*

THE RELATIONAL DATABASE MANAGEMENT SYSTEM THAT IS BEST IS THE *RL1

Circle 217 on inquiry card.

PConnection

Three functions in one card slot—
Modem, Calendar clock, Serial port!

The PConnection is a premium telecommunications card for the IBM PC with a direct connect Bell 103/113 modem, a real time clock, and a serial I/O port for expanded communications capabilities. The PConnection gives you all three functions in a single card slot!

The PConnection has autodial (Touch Tone or pulse) and autoanswer, plus a built-in speaker for line status monitoring. Software selectable protocol and modes.

The real time clock can be used to auto-dial predetermined phone numbers at preset times. Excellent for polling and remote monitoring applications.

PConnection (plug-in modem) - \$250. Enhanced PConnection with real time clock and additional RS-232 - \$300. Another quality modem from...

the microp peripheral corporation
2565 152nd Avenue N.E.
Redmond, WA 98052
(206) 881-7544

IBM is a registered trademark of International Business Machine Corporation

Circle 270 on inquiry card.

AT LAST!!

The first full featured
Graphics + Terminal board
for the S100 bus

- Programmable resolution up to 512x576
- Terminal formats: 85x24 or 85x40
- Emulates an H19/Z19 terminal
- Data rates in excess of 9600 baud
- Multiple graphics planes
- I/O mapped (doesn't waste host RAM)
- Sprite manipulation handled on board
- On-board CPU handles CRTC and processes commands in parallel with host
- Simple yet powerful graphics commands make your applications fast and easy
- Drivers and example programs included

paraGraphics P.O. Box 67 S. Easton, MA 02375 (617) 620-4513	Assembled \$595. Full kit \$525. Partial kit \$295. MasterCard/Visa
--	--

paraGraphics

Circle 307 on inquiry card.

DISKETTES

maxell. VERBATIM

100% ERROR FREE 5% SS/DD 28.95 (BOX 10)	DATALIFE 5% SS/DD 24.95 (BOX 10)
---	--

CAPTAINS SPECIAL
BUY ONE BOX MAXELL GET 10% OFF 2nd BOX

VERBATIM HEAD CLEANING KIT
8.95
WITH ORDER OF DISK MX - 80 CARTRIDGE 4.95 EA.

MEGA-BYTE
4890 S.W. 45th STREET
FORT LAUD., FLA 33314
305-587-1130



Circle 254 on inquiry card.

MEMOREX FLEXIBLE DISCS

WE WILL NOT BE UNDER-SOLD!! Call Free (800)235-4137 for prices and information. Dealer inquiries invited and C.O.D.'s accepted.

PACIFIC EXCHANGES
100 Foothill Blvd.
San Luis Obispo, CA 93401. In Cal. call (800)592-5935 or (805)543-1037



Circle 299 on inquiry card.

Alspa Computer, Inc.

Price-performance leader. Includes Z80A, 8" ds/dd drives, 3 serial + 1 parallel port, winchester port, networking. Prices start below \$1500. DEALER / OEM inquiries invited.

SPECIALS on INTEGRATED CIRCUITS

6502	7.45	10/ 6.95	50/ 6.55	100/ 6.15
6502A/6512A	8.40	10/ 7.95	50/ 7.35	100/ 6.90
6520 PIA	5.15	10/ 4.90	50/ 4.45	100/ 4.15
6522 VIA	6.45	10/ 6.10	50/ 5.75	100/ 5.45
6532	7.90	10/ 7.40	50/ 7.00	100/ 6.60
2114-L200		2.45	25/ 2.30	100/ 2.15
2716 EPROM		4.90	5/ 4.50	10/ 4.00
2532 EPROM		6.90	5/ 6.75	10/ 6.45
6116 2Kx8 CMOS RAM		6.90	5/ 6.75	10/ 6.45
4116 RAM			8 for 14	
Zero Insertion Force 24 pin Socket (Scanbe)				2.00

Hewlett Packard



Write or call for prices.

Anchor Automation Signalman Modems

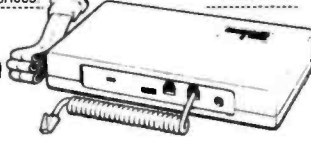

FREE SOURCE MEMBERSHIP WITH SIGNALMAN

All Signalman Modems are Direct Connect, and include cables to connect to your computer and to the telephone. Signalman Modems provide the best price-performance values, and start at less than \$100. Dealer and OEM inquiries invited

Mark I RS232	(99)	79
Mark II for Atari 850	(99)	79
Mark IV for CBM/PET with software	(169)	119
Mark V for Osborne (software available)	(129)	93
Mark VI for IBM Personal Computer	(279)	195
Mark VII Auto Dial/Auto Answer	(179)	119
Mark VIII Bell 212 Auto Dial/Answer	(399)	319

DC HAYES Smartmodem	219
DC Hayes Smartmodem 1200	545



PROM QUEEN for VIC	170
Apple Emulator for Commodore 64	89
Screenmaker 80 COLUMN CARD for C64	145
Solid Oak 2 Level Stand for C64 or VIC	29
C64/VIC Switch (networking)	125
BACKUP V1.0 tape copier for C64 or VIC	20
CARDBOARD/6 Motherboard - VIC	64
CARDAPTER/1 Atari VCS Adapter - VIC	69
CARDPRINT Printer Interface - C64/VIC	64
CARDBOARD/3s Motherboard - VIC	32
CARDWRITER Lightpen - C64/VIC	32
CARDRAM/16 RAM Expansion - VIC	64
Complete CARDCO Line in stock	
CIE and VIE IEEE Interfaces in stock	
BASM kCompiler/Assembler for C64	89

APPLE—FRANKLIN ITEMS

KRAFT Apple Joystick	43
16K RAM Card for Apple	59
Solid Oak 2 Level Stand for Apple	29
Serial Card for Apple	99
MPC RAM/80 column card for IIE	139
Z80 Softcard and CP/M (Microsoft)	235
RANA Elite I with Controller	389
Parallel Printer Interface/Cable	79
Apple Dumping (Microtek) Printer Interface	115
Apple Dumping with 16K Buffer	160
Grappler + Interface	140
Kraft Products for Apple in stock	
DC Hayes Micromodem II	299
PFS: File	100
PFS: Report	100
Videx 80 Column Card	209
Hayden Software for Apple 20% OFF	
PIE Writer Word Processor	120

Commodore

See us for Personal, Business, and Educational requirements. Educational Discounts available.

PETSCAN I \$245 base price

Allows you to connect up to 30 CBM/PET Computers to shared disk drives and printers. Completely transparent to the user. Perfect for schools or multiple word processing configurations. Base configuration supports 2 computers. Additional computer hookups \$100 each.

COMPACK \$115

Intelligent Terminal Package for PET, CBM, C64
Includes ACIA Hardware / STCP Software

VE-2 IEEE to Parallel Interface 110

Includes case, power supply, full 8-bit transmission, and switch selectable character conversion to ASCII.

VIDEO ENHANCER for Commodore 64 89
Realize video quality equal or better than composite monitor using standard color TV.

SCREENMAKER 80 Column Adapter for C64 145
Provides big screen capability for business applications.

VIC 20 Products	VIC Sargon II Chess	32
BACKUP V1.0	VIC GOLF	32
VIC RAM Cards in stock	Meteor Run (UMI)	39
VIC SuperExpander	VIC Radar Rattrace	24
VIC 16K RAM	Amok (UMI)	20
Thorn EMI Software	Snakman	15
HES Software	Rubik's Cube	13
VIC Omega Race	Programmers Reference 15	
Spiders of Mars (UMI)	FROGGER	25
Programmers Aid	VIC Adventure Series	
VICTORY Software for VIC and C64		
Street Sweepers (VIC)	Kongo Kong (VIC)	16
Night Rider (VIC)	11 Cosmic Debris (VIC)	12
Annihilator	16 Adventure Pack I	16
Adventure Pack II	16 Metamorphosis	11
Educational Pack I	11 Trek	12
Strategy Pack I	16 Grave Robbers	12
Commodore 64 Programmers Reference Guide		16
MicroChess for C64—8 levels of play		19
Computer's First Book of PET/CBM		11
C64 or VIC SWITCH		125
POWER ROM Utilities for PET/CBM		78
WordPro 3+/64		69
WordPro 4+ - 8032 disk, printer		295
SPELLMASTER spelling checker for WordPro		170
VISICALC for PET, ATARI, or Apple		189
PET-TRAX PET to Epson Graphics Software		40
SM-KIT enhanced PET/CBM ROM Utilities		40
Programmers Toolkit - PET ROM Utilities		35
CALC RESULT for C64		135
PET Spacemaker II ROM Switch		36
COPYWRITER Word Processor for C64		69
2 Meter PET to IEEE or IEEE to IEEE Cable		40
Dust Cover for PET, CBM, 4040, or 8050		8
CmC Interfaces (ADA1800, ADA1450, SADI in stock)		
ZRAM - CBM 64K RAM, Z80, CP/M		550
Programming the PET/CBM (Computer) — R. West		20
Computer's First Book of VIC		11
HES MODEM with Software		65
HES Software and Hardware in stock		
UMI products in stock		
OMNICALC (HES) Spreadsheet for C64		79

MicroChess for C64—8 levels of play 19
Computer's First Book of PET/CBM 11

C64 or VIC SWITCH	125
POWER ROM Utilities for PET/CBM	78
WordPro 3+/64	69
WordPro 4+ - 8032 disk, printer	295
SPELLMASTER spelling checker for WordPro	170
VISICALC for PET, ATARI, or Apple	189
PET-TRAX PET to Epson Graphics Software	40
SM-KIT enhanced PET/CBM ROM Utilities	40
Programmers Toolkit - PET ROM Utilities	35
CALC RESULT for C64	135
PET Spacemaker II ROM Switch	36
COPYWRITER Word Processor for C64	69
2 Meter PET to IEEE or IEEE to IEEE Cable	40
Dust Cover for PET, CBM, 4040, or 8050	8
CmC Interfaces (ADA1800, ADA1450, SADI in stock)	
ZRAM - CBM 64K RAM, Z80, CP/M	550
Programming the PET/CBM (Computer) — R. West	20
Computer's First Book of VIC	11
HES MODEM with Software	65
HES Software and Hardware in stock	
UMI products in stock	
OMNICALC (HES) Spreadsheet for C64	79

FlexFile for PET/CBM/ C64 \$110

Database, Report Writer with calculations, Mailing Lists.

FORTH for PET/C64 full FIG model—Cargill/Riley	\$50
Metacompiler for FORTH for independent object code	30
KMMM PASCAL for PET/CBM/C64	79
EARL for PET/CBM Disk-based ASSEMBLER	65
Super Graphics — BASIC Language Extensions	45
Fast machine language graphics routines for PET/CBM	
RAM/ROM for PET/CBM	4K \$75 8K \$90
DISK ICU — Recovery System for PET/CBM	40

DISK SPECIALS



Scotch (3M) 5" ss/dd	10/ 2.20	50/ 2.00	100/ 1.95
Scotch (3M) 5" ds/dd	10/ 3.05	50/ 2.80	100/ 2.75
Scotch (3M) 8" ss/sd	10/ 2.30	50/ 2.10	100/ 2.06
Scotch (3M) 8" ss/dd	10/ 2.85	50/ 2.70	100/ 2.65

We stock VERBATIM DISKS

Write for Dealer and OEM prices.

Sentinal 5" ss/dd	10/ 1.90	50/ 1.85	100/ 1.80
Sentinal 5" ds/dd	10/ 2.55	50/ 2.50	100/ 2.45
Wabash 5" ss/sd	10/ 1.65	50/ 1.60	100/ 1.55
Wabash 5" ss/dd	10/ 1.95	50/ 1.90	100/ 1.85
Wabash 8" ss/sd	10/ 2.00	50/ 1.95	100/ 1.85

We stock MAXELL DISKS

Write for dealer and OEM prices.

Disk Storage Pages	10 for \$5	Hub Rings 50 for \$6
Disk Library Cases	8"—3.00	5"—2.25
Head Cleaning Kits	11	

CASSETTE TAPES—AGFA PE-611 PREMIUM

C-10	10/ .61	50/ .58	100/ 50
C-30	10/ .85	50/ .82	100/ 70

DATASHIELD BACKUP POWER SOURCE 285

Battery back up Uninterruptible Power Supply with surge and noise filtering. The answer to your power problems.

Zenith ZVM-121 Green Phosphor Monitor	98
BMC 12A 12" Green Monitor	85
VOTRAX Personal Speech System	280
VOTRAX Type-N-Talk	160
VOICE BOX Speech Synthesizer (Apple or Atari)	
CompuServe Subscription (5 hours free)	32
Brother HR-15 Daisy Wheel Printer	475
Prowriter Parallel Printer	379
Panasonic 1090 Printer with Correspondence Mode	365
USI CompuMOD 4 R F Modulator	39
Daisywriter 2000 with 48K buffer + cable	1150
Many printers available (Gemini-Star, Brother, DKL, etc.)	

We Stock AMDEK Monitors

Amdek DXY-100 Plotter	590
A P Products	15% OFF
Watanabe Intelligent Plotter 990	6-pen 1290
BROOKS 6 Outlet Surge Suppressor/Noise Filter	54
We stock Electrohome Monitors	
Synertek SYM-1 Microcomputer	189

ALL BOOK and SOFTWARE PRICES DISCOUNTED

Panasonic TR-120M1P 12" Monitor (20 MHz)	149
Panasonic CT-160 Dual Mode Color Monitor	285

USI Video Monitors—Green or AMBER 20 MHz hi-res.
Dealer and OEM inquiries invited

ZENITH data systems

Z29 Terminal (DEC and ADM compatible)	680
ZT-1 Intelligent Communications Terminal	369
ZT-10 Intel Terminal with Serial Port	340
Z100 16-bit/8-bit Systems in stock	CALL
We stock entire Zenith line	



WE STOCK ENTIRE LINE—write for prices.

Atari 1200	CALL	QIX	34
Voice Box	100	Anchor Modem—Atari	79
FROGGER	25	Atari Graphics (Computer)	11
Thorn EMI Software		First Book of Atari	11
EduFun Software		APX Software	

WRITE FOR CATALOG. Add \$1.50 per order for United Parcel. We pay balance of UPS surface shipping charges on all prepaid orders (add extra for mail, APO/FPO, air). Prices include cash discount. Regular prices slightly higher. Prices subject to change.

215-822-7727
252 Bethlehem Pike
Colmar, PA 18915

A B Computers

U.S. MICRO SALES

★ MADE IN USA ★ BUY FACTORY DIRECT ★

SAVE! DISK DRIVE SAVE! BLOWOUT SALE

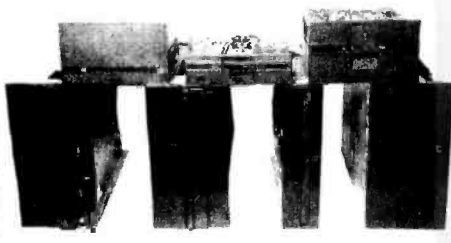

THE LOWEST PRICES IN BYTE!

8" Shugart 801R SS/DD - Slashed	\$355.00
8" Shugart 851R Double Sided 1.2 Meg!	457.00
8" Qume Datalrak-8 DS/DD "THE BEST"	479.00
8" Mitsubishi Full Height Double Sided 1 Year P+L	445.00
8" Mitsubishi Thinline DS/DD 1 Year Parts + Labor	465.00
8" Tandon 848-1 Slimline SS/DD 600K BYTES	355.00
8" Tandon 848-2 Slimline Double Sided 1.2 Meg.	475.00
8" Siemens 100-8 SS/DD ON SALE NOW!!!	169.00
5 1/4" Mitsubishi Full height 96T.P.I. DS/DD 750K	295.00
5 1/4" Mitsubishi Slimline 96T.P.I. DS/DD 750K	315.00
5 1/4" Tandon TM-100-1 SS/DD 48T.P.I. 168K	199.00
5 1/4" Tandon TM-100-2 I.B.M. PC Add-on!	259.00
5 1/4" Tandon TM 100-4 DS/DD 96T.P.I. 750K	369.00

★ WINCHESTER HARD DISKS ★

5 1/4" Miniscribe 5 Meg* Hard Disk - Affordable	\$695.00
5 1/4" Miniscribe 10 Meg* Hard Disk - Twice the Space	850.00
5 1/4" Miniscribe 16 Meg* Hard Disk - Best Buy	995.00
5 1/4" Miniscribe 10 Meg* Thinline only 1 1/2 inches wide!	795.00
8" Quantum 20" Megabyte Winchester - Two Platters	1895.00
8" Quantum 40" Meg Four Platter - Most Popular	2395.00
8" Quantum 85" Megabyte - Special Order on this Monster!	2895.00
8" IOMEGA ALPHA 10-10 Megabyte* Removable Disk Cartridge with SCSI Microprocessor Controlled Interface (Controls up to Four IOMEGA Cartridge Drives)	1895.00
IOMEGA 10 Megabyte Cartridge - No Interface P.C.B.	895.00

★LAST MINUTE SPECIAL!!! Buy any Winchester hard disk drive above and get a Western Digital hard disk interface board AT COST! ONLY 295.00!
*Total storage space after formatting.

DUAL DRIVE SUBSYSTEMS



HORIZONTAL OR VERTICAL Fully Assembled and Tested Units ONE YEAR P+L WARRANTY On Shugart and Mitsubishi Subsystems

w/two Mitsubishi DS/DD Assem. + Tested	\$1170.00
w/two Shugart 801R SS/DD Assem. + Tested	975.00
w/two Shugart 851R DS/DD Assem. + Tested	1225.00
w/two Siemens 120-8 SS/DD Assem. + Tested	675.00
w/two Qume DT-8 DS/DD Assem. + Tested	1250.00
Cabinet A & T w/Power Supply and Accs.	235.00
Cabinet Top and Bottom	Only 69.50

All cabinets A & T and subsystems include all AC/DC wiring and 50 pin data cable except the horizontal model which includes the internal 50 pin cable and requires an external 50 pin cable part #C-5000-01 \$ 25.00

5 1/4" Subsystems	
w/two 48TPI SS/DD includes all cables	495.00
w/two 48TPI DS/DD includes all cables	595.00
w/two 96TPI DS/DD includes all cables	695.00



8" POWER For Two 8" Floppys

- +5VDC @ 4 Amps
- +24VDC @ 3 Amps
- 5VDC @ 1 Amp

ONLY 59.95



S-100 POWER For 6 to 22 Slots

- +8VDC @ 30 Amps
- +16VDC @ 6 Amps
- 16VDC @ 6 Amps

ONLY 89.50

*UNIVERSAL POWER SUPPLY . . . 69.95

HAYES SMARTMODEM 1200 THE LEADER OF THE HAYES MODEM FAMILY

- 1200 Baud - Bell 212A Compatible
- 300 Baud - Bell 103 Compatible
- Automatic Dialing - Touchtone or Pulse
- Automatic Send, Receive and Disconnect
- Built-in Speaker for Monitoring Call Line

These are just a few features of the Smartmodem 1200, the best modem you can buy. In fact, it performs just about any communication function you can imagine, and can be program controlled using any language. Our special price \$549.00
★Make things easy for yourself. Get the Hayes Smartmodem 1200 with CROSSALK™ software. \$629.00

FANTASTIC SAVINGS!



\$395

ON THE ORIGINAL S-100 MOD

For engineers, hobbyists, and anyone who wants to save a bundle, the S1-MOD is the answer. Full regulated power to run up to four floppy disks coupled with a mammoth S-100 power supply and 12 slot bus, makes the S1-MOD an exceptional computer base. Single board design means no wiring from the power supply to the motherboard. This eliminates all ground loop problems associated with other brands of mainframes who are forced to use termination. The S1-MOD is being offered this month with a matching S-100-12 cabinet. Fan cooled, fused, with reset and keylock the cabinet is also enamel painted and silk screened. Four A.C. outlets are provided for peripheral hookup and plenty of cutouts available for RS-232, centronics + others. Our regular \$225.00 price for the S1-MOD and 250.00 price for our 12 slot cabinet is being SLASHED!

★★★ SPECIFICATIONS ★★★

Input	Regulated	Unregulated
120V/60HZ.	+5V @ 5A	+8V @ 30A
230V/50HZ.	+24V @ 3A	±16V @ 6A
	-5V @ 1A	

Don't settle for those cheap 6 slot imitations you've seen elsewhere in this mag. OWN THE BEST! XOR S-1 MOD and S-100-12 Cabinet . . . \$395.00!



California Computer Systems

CCS SYSTEM 2410 . . \$1995.00

- ★ Includes CP/M® 2.2
- ★ DMA Disk Controller
- ★ 2-Serial/1-Parallel Port
- ★ Hardware Vectored Interrupts
- ★ 2-Real Time Clocks
- ★ Supports CP/M®, MP/M®, OASIS

CCS 2300 System, A & T . . \$1695.00

- ★ Includes CP/M® 2.2
- ★ 2300 Mainframe
- ★ 2810 Z-80A CPU
- ★ New 2066 64K Memory
- ★ 2422 Disk Controller
- ★ Complete A+T

- ★ 2710 4 Port Serial . . . \$245.00
- ★ 2719 2 Serial - 2 Parallel . . . 245.00
- ★ 2810 CPU Z-80 at 4 MHz . . . Only-255.00
- ★ 2422 Disk Controller with CP/M 2.2 . . . Only-330.00
- ★ 2066 64K Dynamic Memory . . . Only-360.00
- ★ 2300A Mainframe Assem. + Tested . . . Only-455.00
- ★ CCS Apple Boards . . . Call Toll Free For Prices

CUSTOMER SERVICE HOTLINE 1 - (714) 898-5525

MICRO COMPUTERS FOR MICRO\$DOLLARS



XOR 500

A matching terminal with a detachable keyboard and green screen for under \$500.00? See description on opposite page.

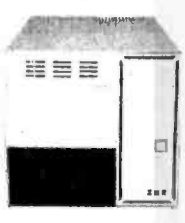

\$995.00

A computer for under 1,000 dollars? YES, U.S. MICRO SALES is offering for limited time only, a 4 slot-S-100 bus computer system at \$995. Full 64K of memory means there's no need to add any memory. With 64K and CP/M 2.2 operating system (included) you're able to run over two thousand different software application packages. Formats? This little system will read MORROW, IBM, KAYPRO, and XOR Formats. The disk controller is so advanced it can write any byte/size sector, single or double sided single or double density AND . . . it runs both 8" and 5 1/4" drives! If more storage is needed, add on an 8" subsystem and you'll be able to READ AND WRITE the IBM 3740 Format - an industry standard. The system above includes 5 1/4" floppy storage, 4 slot S-100 bus, 3 board set with Z-80A @ 4MHz., 2 serial RS-232 ports, Centronics parallel port and two whole diskettes full of free utility software along with CP/M 2.2.

S-100-4 Mini 5 1/4" System #S-1000-83 . . . \$995.00
Limit 1 to a customer - offer expires Sept. 15th 1983

SEIKOSHA - Meaning high quality and low cost in a cut matrix design. Full Graphics, parallel interface, 80 column, double width print, and automatic printing make this printer a "Best Buy". Quality? You bet, and backed by a two year end user warranty. Seikosha GP-100A, 2 year warranty \$239.00



XOR 500

- A new video display terminal featuring:
 - ★ screen tilt
 - ★ detachable keyboard
 - ★ 9 cursor control keys
 - ★ 5 function keys
 - ★ 7 screen attributes
 - ★ 25th status line
 - ★ 50-128 baud
 - ★ column
 - ★ field size
 - ★ and more . . .
- All these features with a full 6 month warranty make this terminal the best buy on the market.
- XOR 500, #T-1000-15 . . . \$495.00

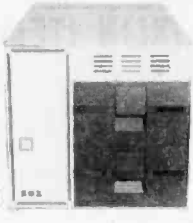

HARD DISK
\$1995.00

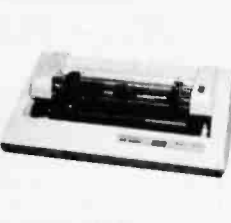

Once again Seikosha has come out with a fantastic buy! The GP-250X. For starters, there is mammoth set aside for you to define 64 of your own characters or symbols. There's more memory for storing your own print sequences, up to four of them. BOTH serial and parallel interfaces - STANDARD. Self test mode - STANDARD. Graphics, double width and/or double height characters - STANDARD. SEIKOSHA GP-250X, 2 year warranty \$295.00

At the price of a hard disk subsystem, this expandable, upgradeable hard disk microcomputer is obviously a "BEST BUY". Z-80A based at 4MHz, with 64K of dynamic memory and CP/M 2.2 allows you to run thousands of available software programs. A full 5 megabytes of formatted storage provides plenty of storage for programs and data. High speed data transfer is accomplished with a Western Digital hard disk controller. Our on board program monitor allows booting up CP/M from the floppy or hard disk. Factory direct delivery gives you factory direct service if it is ever needed. The hard disk system is available in many different configurations should you require 3 or 4 floppys or a large hard disk. The readable formats for this system now include IBM, MORROW, KAYPRO and XOR. Adding a pair of 8" drives is no problem as the software you receive will also have 8" format-copy read and write files. The XOR disk controller will run both 8" and 5 1/4" floppys simultaneously giving you the ability to read + write the IBM 3740 format, an industry standard. Features also include two separate power supplies, a 5 board set, an S-100 bus structure, serial and parallel ports and a spare S-100 slot for your own expansion. All this gives the XOR S-100-4 hard disk system the qualities needed to remain a step ahead in the microcomputer industry.

XOR S-100-4 Hard Disk #S-1000-89 . . . \$1995.00
Limited quantities - one per customer - expires 9/15/83



ORDER TOLL FREE

★ EAST ★

★ WEST ★

1 (800) 435-9357

1 (800) 854-8174

In Ill. (815) 485-4002

In Calif. 1 (714) 898-1492

TERMS: We accept VISA/MC, prepay, check or money order. Please allow personal check two weeks to clear before shipment. \$5.00 handling charge on all orders under \$50.00. 15% Restocking Fee. All orders shipped via U.P.S., unless otherwise specified. All UPS C.O.D. orders over \$100.00 require a Cashiers Check. ★ Our products carry a full 6 months parts and labor warranty excluding drives, printers and terminals which carry the full O.E.M. factory warranty. PRICES SUBJECT TO CHANGE WITHOUT NOTICE.

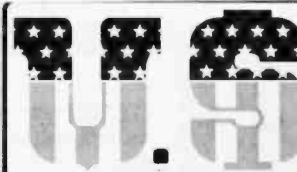

MICRO SALES

★ MADE IN USA ★ BUY FACTORY DIRECT ★

★ EAST ★ 11 Edison Drive, New Lenox, Illinois 60451

★ WEST ★ 15392 Assembly Lane, Huntington Beach, CA 92649

OUR BEST SELLING TERMINALS

Adds Viewpoint: A low cost high performance terminal w/green screen and detachable keyboard. Features include ★ Reverse video ★ half intensity ★ Visual highlighting ★ Full auxiliary port use ★ 150 - 19.2K baud rate ★ Screen tilt ★ Foreign language international character set ★ 4 way cursor setting ★

ADDS VIEWPOINT #T-1000-04 \$519.00

Televideo 910+: Save your eyes on a great green screen w/features like ★ Built-in self test ★ Full editing ★ Tab options ★ cursor control ★ 16 visual attributes like, reverse video, monitor mode, half intensity and block or underline, blink or steady cursor ★ Full numeric keypad ★ 925/950 emulation ★.

TELEVIDEO 910+ #T-1000-05 \$569.00

XOR 500: A new video display terminal featuring ★ Screen tilt ★ Detachable keyboard ★ 9 cursor control keys ★ 5 function keys ★ 7 screen attributes ★ 25th status line ★ 50-19.2K baud ★ Column + field tab ★ and more ★ All these features with a full 6 month warranty make this terminal the best buy on the market.

XOR 500 #T-1000-15 \$495.00

Televideo 925: From the hobbyist to the basic professional this popular terminal will fit your needs. ★ Detachable keyboard ★ Numeric keypad ★ Green screen ★ Self test ★ Time of day display ★ Programmable function keys ★ 912/920 emulation hardware/software programmable configurations ★ Extra memory page ★ Four switchable foreign languages ★ Tilt screen ★ 25th status line ★

TELEVIDEO 925 #T-1000-08 \$739.00

TELEVIDEO 950 #T-1000-09 \$939.00



PRINTERS NEW ARRIVALS! NEW MODELS!

Mannesman Tally MT 180 - IN STOCK!!! New design and technology with a price tag that will knock your socks off. The MT-180 is the most sought after printer currently on the market. This printer is the answer to all your printer needs. You get high resolution business graphics, outstanding letter quality text for word processing, and continuous high speed report printing! Eight letter widths give your printout a change of pace. On the 132 column width concaves 264 columns. The dual shift print head with a 20 x 18 matrix prints outstanding letter quality type. So good you'll think you've invested in a daisywheel. (Not convinced? Serial and parallel hookup - STANDARD) 96 characters ASCII draft quality, 96 characters letter quality, 11 graphic symbols, 31 Greek characters, 6 foreign languages, bi-directional logic seeking dual shift printhead. AND Program by menu! Ever tired to figure out the switch settings on a printer? The MT-180 has push button "PROMPT" programming. Answer questions YES or NO to set up formats & character sets, & communications with your printer! The last feature is the reason you'll soon own an MT-180. THE PRICE \$995.00

Okidata Microline: New versatility, correspondence quality printing and speed make the ML92 and ML93 the best printer values in their categories. Both printers provide multi-speed print modes: bi-directional high speed mode with short line seeking logic at 160cps, emphasized and enhanced mode printing at 80cps, and high resolution correspondence quality printing at 40cps. Dot-addressable graphics is standard. Both serial and parallel models are available and BOTH prices include full tractor assembly at no extra charge.

ML92 (Serial Add \$85) #M-2000-10 \$ 629.00

ML93 (Serial Add \$85) #M-2000-11 \$ 555.00

Seiko: - Meaning high quality and low cost in a dot matrix design. Full graphics, parallel interface, 80 column, double width print, and automatic printing make this printer a "best buy". Quality you bet, and backed by a two year end user warranty.

Seiko GP-100A 2-year warranty \$239.00

Daisywriter 2000: An innovation in daisywheel letter quality. Printwheel cassettes, first introduced by Daisywriter, are enclosed printwheels to prevent damage or breakage of those costly daisy wheels. These cassettes are available in 14 print styles and 16 languages. Over 75 software commands makes word processing easy. Almost a word processor in itself! AND standard serial interfacing, 16K (40K optional) buffer. That's right sixteen K of memory allow you to "spool" to the buffer in less than a second and print for up to an hour with optional low cost direct feeder or tractor. PLUS automatic margin, auto proportional spacing, Daisyprint graphics with absolute and relative vector plotting, auto baud rate, self test, 132 to 264 column print, full line spacing an MORE! Need to print 3 or 4 part forms? No problem as the D-2000 handles the original and up to 7 copies. Don't feel you'll be getting stuck with a low speed letter quality printer - 200 CPS high speed "white space" printing will get that 30 page report out in no time. Daisywriter 2000 \$1150.00



The 4 slot S-100 systems below are equipped with XOR Z-80 4MHZ three board set. Each can run 8" or 5" disk simultaneously. In addition to the high speed XOR mini format, they can read KPRO, IBM and Morrow 5" disk formats. Each has a modular dual power supply sub chassis. They are fan cooled. Standard I/O is 2 serial ports and one centronics parallel. Expansion I/O is available.

MICRO MANAGER TWIN 5 1/4" MINI



Don't be fooled by this system's small portable size.

- Full 64K of memory with an industry standard S-100 bus
- Includes CP/M 2.2 and many utilities on two disks
- Add on a hard disk when you need more storage

★ ★ COMPLETE SYSTEMS ★ ★

Dual Floppy 368K SS/DD	\$1445.00
Dual Floppy 750K SS/DD	\$1595.00
Dual Floppy 1.5 Meg DS/DD	\$1645.00
Chassis (No boards No drives)	\$ 425.00

MICRO MANAGER MINI HARD DISK SYSTEMS

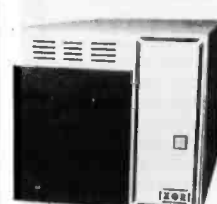

Inexpensive but powerful, small enough for portability, these mini hard disk systems have a special XOR interface to the S-100 bus that leaves an S-100 slot open for expandability. Choose from 5, 10, and 16 megabyte sizes (6.5, 12, + 20 megabyte unformatted.)

5 Megabyte Hard Disk w/750K Floppy	\$2345.00
10 Megabyte Hard Disk w/750K Floppy	\$2475.00
16 Megabyte Hard Disk w/750K Floppy	\$2545.00

Many Other Configurations Available - Ask Us!

8" MICRO MANAGER

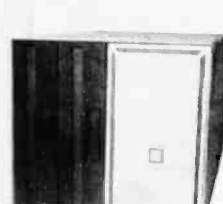

Our most popular computer features a 4 slot S-100 bus and 8" industry standard format. Reads and writes the IBM 3740 format as well as any byte/size sector. Expandable? Yes, add a hard disk or cartridge subsystem when your data base grows, includes CP/M.

★ System with SS/DD 1.2 Megabytes	\$1795.00
★ System with DS/DD 2.4 Megabytes	\$1995.00
★ System with NO Drives (includes CP/M)	\$1195.00
★ System Chassis (No boards, no drives, no CP/M) \$	395.00

The 12 slot commercial grade S-100 systems below have all of the features listed above plus a massive 30 amp power supply capable of the expansion we expect you will do. All units are cooled by four inch fans. Each system must pass 2 days of constant read and write disk testing without a single error before shipment. **One year complete warranty is included.**

BASIC PROFESSIONAL

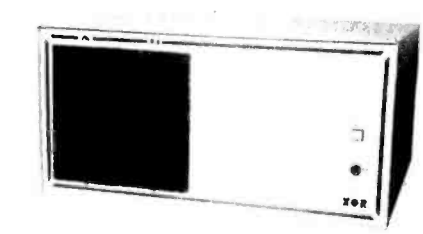

★ w/2 SS/DD 1.2 Megabytes	\$2295.00
★ w/2 DS/DD 2.4 Megabytes Full Ht. or Slimline	\$2345.00
Buy the basic professional with thinline drives if you plan to upgrade to a hard disk in the future.	
★ System w/no Drives (Includes CP/M)	\$1350.00
★ 12 Slot Chassis w/no Boards, Drives, or CP/M	\$ 495.00

OFFICE MASTER REMOVEABLE CARTRIDGE DISK SYSTEM

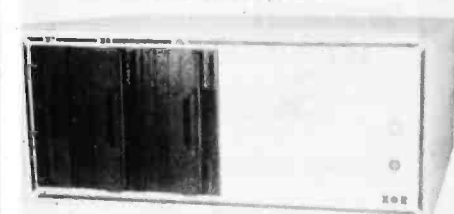

Your storage problems have been solved! Two 10 megabyte 10MEGA removeable cartridge drives with the speed and reliability of a hard disk means you NEVER run out of storage. Just pop in another 10 meg cartridge. Imagine 20, 50 over 100 megabytes of data at your fingertips. All systems include 2 cartridges and CP/M 2.2 operating system.

Good ★ 10 Meg Removeable cartridge w/1.2 meg Floppy	\$3895.00
Better ★ 10 Meg Removeable cartridge w/two 1.2 meg Floppies	\$4195.00
Best ★ Two 10 Meg Removeable cartridge drives	\$4595.00
★ 10 Megabyte cartridges - Stock up now	\$ 50.00

PROFESSIONAL 8" HARD DISK MULTI USER CAPABILITY 2-7 USERS

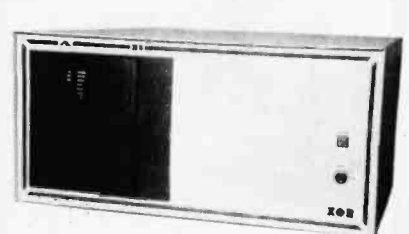

Buying direct from our factory through our East or West coast sales locations assures you of a system that fits your needs. All professional 8" systems are custom built to the customer's specifications. You'll not find this kind of flexibility with any computer company, anywhere. 10, 20, 40, and 85 megabyte systems with DS/DD 1.2 meg. floppy - 10 meg. \$4395.00 / 20 meg. \$4895.00 / 40 meg. \$5745 / 85 meg. \$5345 - Two user hard disk systems add \$695.00 (includes CP/M & MP/M) - Three to Seven users add only \$250.00 per user - 17 Megabyte cartridge tape backup add \$1495.00

VT100

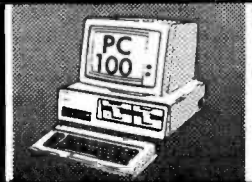

OUR **PC100™** SOFTWARE PACKAGE TURNS
YOUR **IBM® PC** INTO A
DEC® VT100 or VT52
Compatible terminal

Requires: 64k, 1 drive, monochrome or color adpt with
25x80 display, async adpt, and IBM DOS or QUNIX™
PRICED: \$89. (Std. VT100 functions)
Optional: Local Printer & Copy to/from Disk.

GMS 7525 MITCHELL RD.
SUITE 101 CALL OR WRITE
EDEN PRAIRIE, MN 55344 (612) 937-9194

IBM is a registered trademark of International Business Machines.
DEC, VT are registered trademarks of Digital Equipment Corp.
QUNIX is a trademark of Quantum Software Systems.
PC100, GMS are trademarks of General Micro Systems.

Circle 177 on Inquiry card.

CY232 NETWORK CONTROLLER AND PARALLEL-SERIAL INTERFACE

will connect any RS232 CRT or computer
to any 8-bit parallel TTL I/O port
and works with one port or
up to 255 parallel ports
in several network
configurations.

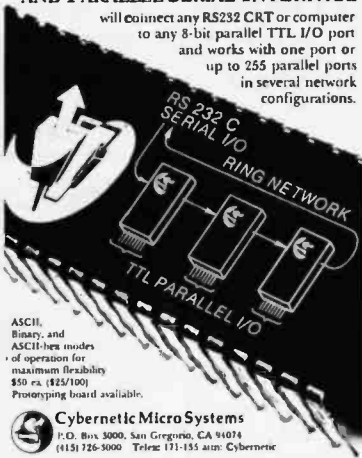

ASCII,
Binary, and
ASCII-hex modes
of operation for
maximum flexibility
\$50 ea. (\$25/100)
Prototyping board available.

Cybernetic Micro Systems
P.O. Box 3000, San Gregorio, CA 94074
(415) 726-3000 Telex: 171-155 azm Cybernetic

Circle 124 on Inquiry card.

Wasting Money! We Have the World's Most Cost Effective Development System.



- Includes HexKit 1.0, a powerful 100% machine code editor / debugger utility program that makes coding for 8-bit Micros a snap.
- Program from Commodore VIC-20 keyboard into built-in 4K ROM emulator
- Jumper to target ROM socket
- Test programs in circuit
- Built-in EPROM programmer and power supply
- Burns & runs EPROMS for the Commodore VIC-20, too
- Comprehensive manuals
- Fits EXPANSION PORT

PROMQUEEN CARTRIDGE ONLY \$189

Send for Free Brochure

Distributed in U.S. by Arbutus Total Soft, Inc., 4202 Meridian, Suite 214,
Bellingham, WA 98226. Phone 800-426-1253. In Washington 206-733-0404
Distributed in Canada by IBC/Distribution Canada, 4047 Cambie St.
Vancouver, BC V5Z 2S8. Phone 604-879-7812

VISA AND MASTERCARD ACCEPTED

commodore approved product

	Prices	U.S.	CAN.
PROMQUEEN 84		\$299.00	\$399.00
8K board with 1 EPROM		\$29.95	\$39.95
16K board with 1 EPROM		\$39.95	\$49.95
8K board with 1 EPROM-C84		\$39.95	\$49.95

Circle 31 on Inquiry card.

ZENITH/ Heath Users

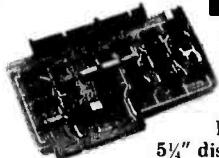

Double Your
5 1/4" disk storage
capacity without adding a drive.

Get twice as much from your H88 or H89 microcomputer. Our FDC-880H floppy disk controller, in conjunction with your 5 1/4" drives, for example, expands memory capacity from 256 bytes to 512 bytes per sector.

And it handles single and double-sided, single and double-density, 8" and 5 1/4" drives — simultaneously.



C.D.R. Systems Inc.

Controlled Data Recording Systems Inc.
7210 Clairmont Mesa Blvd., San Diego, CA 92111
(619) 560-1272

Circle 85 on Inquiry card.

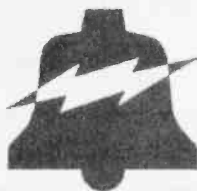

INDUSTRIAL CONTROL MICROCOMPUTERS

We have six single board computers, two video boards and 20 other control products. You can use our products for security systems, heat control, light control, automated slide show, traffic lights, irrigation systems, home computer systems, automated process control, and robot control just to name a few. OEM prices available. For catalog call or write to:

JOHN BELL ENGINEERING, INC.
1014 CENTER STREET
SAN CARLOS, CA. 94070
(415) 592-8411

Circle 47 on Inquiry card.

Convert your TRS-80 into a DEVELOPMENT SYSTEM

Z-80 In-Circuit
emulation and
EPROM/EEPROM
programming in
a single compact
unit.



Debug stand-alone
systems with
program in
TRS-80 RAM,
then copy working program into PROM.

Only \$329 including personality module for 2716, 2516, 2758, 2508, 2532, 2816, 2808, 48016. (2732A, 2764PM's \$15 ea.)

ORION INSTRUMENTS

172 Otis Ave, Woodside, CA 94062
(415) 851-1172

Circle 298 on Inquiry card.

Maxell Floppy Disks

The Mini-Disks
with maximum quality.



Dealer inquiries
invited. C.O.D.'s
accepted. Call
FREE (800) 235-4137.

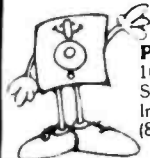

PACIFIC EXCHANGES
100 Foothill Blvd., San Luis
San Luis Obispo, CA 93401.
In Cal. call (800) 592-5935 or
(805)543-1037.

Circle 299 on Inquiry card.

flexible discs

LOWEST PRICES

wabash®
MEMOREX
Scotch™

DEALER INQUIRIES INVITED

FOR
ORDERS
CALL COLLECT
(614) 866-3462



datamaster
A DIVISION OF
KOP International Corp.
5148 ZIMMER DR. COLUMBUS, OHIO 43227

Circle 128 on Inquiry card.
www.americanradiohistory.com

MicroScript™ \$99

State of the Art Text Formatter

- generic markup
- fully delineable page with multiple columns
- multiline headers, footers, and footnotes
- automatic widow and orphan suppression
- automatic section numbering
- automatic table of contents and index
- automatic bullet, number, and definition lists
- floating figures
- text alignment to left, center, right, or justify
- left and right indentation with delay and duration
- bold, underscore, and proportional spacing
- macros and symbols
- multiple input files of unlimited size
- direct printer control
- IDS, Qume, Diablo, NEC, C.I.TOH, and all TTY

MicroEd™ \$49

Customizable Full Screen Editor

- full cursor control by character, word, or line
- position to top or bottom of window or file
- scroll by line, half window, or full window
- global or selective find and replace
- delete by character, word, line, or block
- read external files into current file
- copy, move, and write blocks of text
- insert, overlay, or wordwrap text
- all cursor addressable VDS

Postpaid within U.S. outside U.S. add \$10. CA residents add 6%.

® SSSSD CP/M-80™, and CP/M-86™, 5.25" 5SSDD PC-DOS

MicroType™

6531 Crown Blvd., Suite 3A, San Jose, CA 95120
(408) 997-5026

CP/M-80, CP/M-86 are trademarks of Digital Research. PC-DOS
is a trademark of IBM Corporation.

Circle 274 on Inquiry card.

ORDER WITH CONFIDENCE

from one of the nation's largest
consumer electronic parts distributors!

"FRUIT COOLER"™

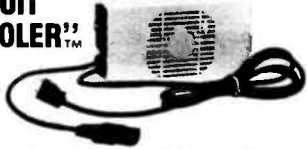

A slim (1 3/4") fan for Apple II® and other computers. Slides on, no installation necessary. Two extra outlets, feeder cable, illuminated switch and spike arrestors.

ORDER NO. 83-APL-FAN-1 **\$54.95**

APPLE COMPATIBLE KEYBOARD



Heavy duty error free switches, switchable N key rollover, last key repeat, upper/lower case capability, alpha lock. Complete with cable.

ORDER NO. 83-APL-KB-7 **\$79.95**

Unbelievable Discount!

APPLE II® COMPATIBLE SLIM DISK DRIVE

RUNS QUIETER THAN THE ORIGINAL!

New - not surplus - guaranteed! Only 6" w x 1-7/8" h x 10" d. Complete with a 3' cable. Runs with Apple controller or our optional controller.



ORDER NO. 84-APL-DD-1

Now only **\$259.00**



CONTROLLER CARD

ORDER NO. 83-APL-CTL-1 **\$49.95**

BONUS Buy two disk drives and get a free controller card!

ATARI® TYPE "DOUBLE FIRE" JOYSTICK

This joystick has a stick top fire button—the newest "craze" in video games!



ORDER NO. 83-XY-250 **\$9.95**

REPLACEMENT POWER SUPPLY FOR APPLE II®



Fully Apple compatible. 5A heavy duty switcher, 110V or 220V input, +5V/5A, +12V/3A, -5V -12V full load outputs. Fits in an Apple II case. AC cord included.

ORDER NO. 83-APL-PS-51 **\$79.95**

APPLE COMPATIBLE JOYSTICK

Heavy duty.

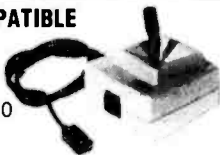

ORDER NO. 83-APL-XY-10

\$16.50

ARCADE TYPE JOYSTICK

Atari, Commodore, Sears compatible. Heavy duty leaf switches. Long life.



ORDER NO. 83-ATR-JY-1 **\$15.00**

REPLACEMENT RAM IC FOR ATARI® 2600 VCS



ORDER NO. 83-ATR-IC-3 **\$11.95**

REPLACEMENT CPU IC FOR ATARI® 2600 VCS



ORDER NO. 83-ATR-IC-2 **\$9.95**

REPLACEMENT R.F. MODULATOR FOR ATARI® 2600 VCS

Also compatible with other video games.



ORDER NO. 83-ATR-RF-1 **\$5.00**

REPLACEMENT AC ADAPTOR FOR ATARI® 2600 VCS

9V 500mA. UL listed.



ORDER NO. 83-ATR-PS-5 **\$5.00**

REPLACEMENT JOYSTICK

Fits Atari, Commodore, Sears others.



ORDER NO. 83-ATR-XY-4 **Now only \$4.95**

REPLACEMENT POWER SUPPLY FOR ATARI® 800 AND 400 MODELS.



ORDER NO. 83-ATR-PS-800 **\$17.00**

JOYSTICK EXTENSION CORDS

Works with Atari, Coleco, Commodore and other 9 pin plugs. Two popular lengths: 6' and 12'.



ORDER NO. 83-ATR-EX-6 **\$5.00**
83-ATR-EX-12 **6.50**

REPLACEMENT ATARI® JOYSTICK CABLE

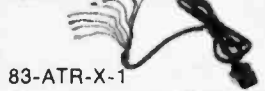

83-ATR-X-1 **\$3.00**

LOGIC PROBE with MEMORY FUNCTION



ORDER NO. 83-3800 A **\$24.95**

We carry a full line of **HITACHI** and **LEADER** oscilloscopes.
Call for your discount prices!

MINIMUM ORDER \$25.00. VISA, MASTER CARD accepted. No surcharges. Exact UPS charges will be added. PREPAID: Certified checks and money orders, send exact amount. No shipping, handling or insurance charges in the continental USA. PERSONAL CHECKS: add 5% shipping charges, allow 3 weeks to clear. INTERNATIONAL BUYERS: US currency and 20% extra for shipping. CA Residents, add sales tax. OEM, DEALERS: send for special prices on your company letterhead. *No purchase orders or open accounts-no exceptions.*



18215 PARTHENIA ST. • NORTHRIDGE, CA 91325

Call toll free: (800) 423-5336
In California: (800) 382-3663
Local: (213) 701-5848
Telex 181011 ORAPARTS NTGE

I WILL BEAT ANY COMPETITOR'S PRICE PROVIDED IT IS NOT BELOW MY COST. TRY TO BEAT THESE IC PRICES:

DYNAMIC RAM		
64K	200 ns	\$5.35
64K	150 ns	5.35
64K	120 ns	5.90
16K	200 ns	1.40
EPROM		
2764	250 ns	\$6.35
2732	450 ns	4.05
2716	450 ns	3.25
2532	450 ns	4.60
STATIC RAM		
6264LP-15	150 ns	\$60.00
6116P-3	150 ns	5.00
2114	200 ns	1.45
Z80A FAMILY		
CPU, CTC, or PIO		\$3.39
DART		7.99
DMA or SIO/0		12.50

MasterCard/VISA or UPS CASH COD
Factory New, Prime Parts
MICROPROCESSORS UNLIMITED

24,000 South Peoria Ave.
BEGGS, OK. 74421
(918) 267-4961

Prices subject to change. Call for volume prices. Subject to available quantities. Shipping & Insurance extra. Cash discount prices shown.

Photo 6-15-83

Circle 489 on Inquiry card.

ULTRA-RES GRAPHICS

IEEE-696 S-100 MONOCHROME	\$495
- 1 x 512 x 512 Pixel	
- Single board system	
IEEE-696 S-100 MONOCHROME / COLOR	\$995
- 1 x 1024 x 1024 Pixel	
- Expandible to 8 x 1024 x 1024 Pixel	
IEEE-696 S-100 EIGHT COLOR	\$1250
- 3 x 512 x 512 Pixel	
- 8 Color RGB	
- Two board system	
MULTIBUS EIGHT COLOR	\$2895
- 3 x 1024 x 1024 Pixel	
- Eight color RGB	
- Single board system	
IBM-PC MONOCHROME	\$495
- 1 x 512 x 512 Pixel	
- 1 x 1024 x 1024 Pixel	\$995
COLOR	\$1295
- 3 x 512 x 512	\$1995
- 3 x 1024 x 1024 Pixel	

FEATURES

Software Drivers, Hardware Zoom, Programmable Display Resolution, Windowing, Multi-Controller Capability, NEC UPD7220 Graphic Controller

ULTRA-RES Trademark CSD Incorporated Starting Prices
MULTIBUS Trademark Intel Corporation
C.S.D. Incorporated
P.O. Box 253 Sudbury, Massachusetts 01776
(617) 443-2750

Circle 61 on Inquiry card.

SUPER PRICES --
SUPER MICROS

SAGE
CORPORATION

68000 processor plus UCSD p-SYSTEM, PASCAL, FORTRAN 77, BASIC, Macro Assembler, full 1 year warranty.

Sage II with 2 QD floppies (1280K) & 128K RAM only \$3300. With 512K RAM, \$3855.

Sage IV w/1 floppy (640K) & 256K RAM, 12 Mbyte hard drive, \$5588. W/1 Mb RAM \$6698.

We are more than just an authorized SAGE dealer, we use the SAGE everyday in our software development business.

MARITIME SOFTWARE ASSOCIATES

(503) 929-2552

6660 Reservoir Road Corvallis, OR 97333

Circle 490 on Inquiry card.

IBM/PC =

1. DEC VT100?
2. DEC VT125?
3. DASHER D400?

SMARTERM™/PC Does It!
At more than
1000 locations worldwide!

- full emulation of terminal characteristics up to the limits of standard IBM PC™ hardware
- includes Integral high-speed, bi-directional ASCII and binary file transfer

OUTSTANDING PRICING:

VT100, VT101, VT102, VT52 ... \$58 to \$150*
VT125 Graphics Terminal ... \$215 to \$295*
Dasher D100, D200, D400 ... \$50 to \$125*
*Depending on quantity

Available through your local computer dealer or directly from:

persoft, Inc. 2740 Ski Lane
Madison, WI 53713
(608) 233-1000
Software for Professionals ... by Professionals

Circle 312 on Inquiry card.

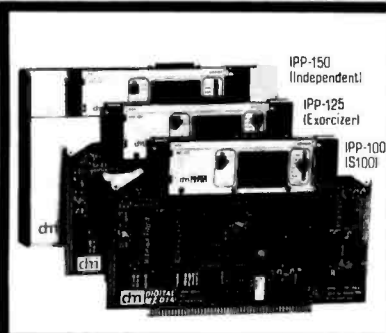

NEW GENERATION OF INTELLIGENT PAL/EPROM PROGRAMMERS - FOR THE NEW BREED OF ENGINEERS

- 20 AND 24 PIN PALs • 27 AND 25 EPROMs • ROM EMULATION

DIGITAL MEDIA
3178 GIBRALTAR AVENUE
COSTA MESA, CA 92626
(714) 751-1373

Circle 144 on Inquiry card.

EPROM PROGRAMMER

\$143

• PROGRAMS

2758
2716
2732
2732A
2764
2516
2532
2564
27129
MCM68766
& MORE!

- RS232, 3-wire, 7 baud rates
- Allows read, copy, verify

Brylar (805) 496-0981

2509 THOUSAND OAKS BLVD - SUITE 108
THOUSAND OAKS, CA 91320

AUGUST SPECIAL



ELEPHANT DISKS
\$19.95/10

PROWRITER 8510 -	\$375
EPSON MX-80 F/T	\$449
GRAPPLER +	\$120
QUENTIN (Applemate)	\$249
MICRO-SCI(A-2)	\$239
CONTROLLER CARD	\$ 69
DISKFILE- (holds 125 disks)	\$ 52

Invitations To Bid - Welcome.
Items in Stock - Ship in 24 Hrs.
We accept, MC, VISA, Certified Check, Money Orders, APO, OK., CA. Residents 6% Tax.
Shipping Min. \$2.50

GWS GOLDEN WEST SYSTEMS
31942 OAK HILL LANE
PORTERVILLE, CA 93257
12091 539-2107

Circle 188 on Inquiry card.

BASF
DISKETTES

BASF Diskettes at competitive price. Call TOLL FREE (800) 235-4137 for prices and information. Visa and Master Card accepted.

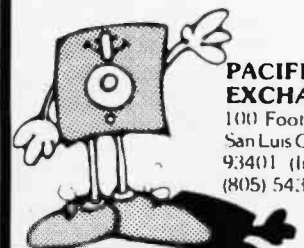

PACIFIC EXCHANGES
100 Foothill Blvd
San Luis Obispo, CA
93401 (In Cal call
(805) 543-1037)

Circle 299 on Inquiry card.

POWER PROTECTION FOR YOUR SYSTEM



The Datasaver™ AC Power Backup fits most desktop and portable microcomputer systems. Call Cuesta Systems, Inc. at (805) 541-4160 for product information and application literature.
VISA/Mastercard orders
INSTANT POWER

Circle 121 on Inquiry card.

DISPLAYED VIDEO IS DRIVING DOWN PRICES ON DISKS! FREE SHIPPING!



TEC'S NEW HALF-HIGH 40 TRACK DISK DRIVE w/CASE & POWER SUPPLY AT AN INCREDIBLE LOW PRICE! \$195.00!!!!

NEW! TRUE HALF HEIGHT DRIVES! 1 5/8 INCH NOT 2 INCH OR 2 7/16 INCH! DIRECT DRIVE! NO DRIVE BELT! 3MS TRACK TO TRACK!

- TEC's New Slimline 40 Track w/case & power supply..... **\$240.00**
 - Tandon 40 Track TM-100-1 w/case & power supply..... **\$225.00**
(DOUBLE SIDED 40 TRACK DRIVES ADD \$75.00)
 - Shugart New Slimline Double Sided 40 Track w/case & P.S..... **\$299.00**
 - Shugart New Slimline Double Sided 80 Track w/case & P.S..... **\$379.00**
 - Tandon Single Sided Slimline 8" Disk Drive w/dual case & P.S.... **\$545.00**
 - Tandon Double Sided Slimline 8" Disk Drive w/dual case & P.S.... **\$625.00**
 - Teac Drive 5 1/4" Cable (FOR MOST COMPUTERS)..... **\$23.99**
(WITH GOLD PLATED CONNECTORS)
 - Teac's Color Computer 1st Drive Only..... **\$389.00**
- ONE YEAR WARRANTY ON TEAC & SHUGART DRIVES/180 DAYS ON TEAC & TANDON
Teac Smart Modem 300 Baud..... **\$225.00** 1200 Baud..... **\$525.00**

PRINTER PRICES

- TEC 80 w/Graphtrax Plus... **\$379.00** Gemini 10..... **\$349.00**
- TEC 80 FT w/Graphtrax Plus... **\$495.00** Gemini 15..... **\$489.00**
- TEC 100 w/Graphtrax Plus... **\$659.00** Citoh Prowriter 8510..... **\$395.00**
- TEC 80 w/Graphtrax Plus... **\$409.00** Starwriter F10..... **\$1169.00**
- TEC 80 w/Graphtrax Plus... **\$569.00** Smith Corona TP1..... **\$595.00**
- TEC 100 w/Graphtrax Plus... **\$805.00**
- Printer Cable 10' long w/gold plated connectors starting at..... **\$25.99**

DV'S EXCLUSIVE "YOU CANT LOSE" SIX MONTH WARRANTY!

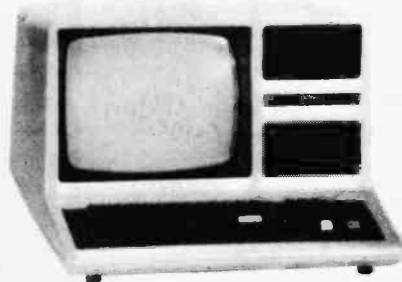

"NO YOU'RE NOT SEEING THINGS, THAT'S FOUR INTERNAL DRIVES IN A MODEL 4, WITH UP TO 4 MEG, DISK STORAGE AVAILABLE NOW!

DV IS DRIVING DOWN PRICES ON DISK!

DISPLAYED VIDEO is now offering TRS-80' MODEL 4 with TANDON/TEC/TEAC disk drives, one of the most reliable disk drive systems on the market, for **INCREDIBLY** low prices.

- MODEL 4 with 64K dual 40 track double density disk drives, complete system with TRSDOS 6.0 and 1 BOX OF DISKETTES
PLUG IT IN AND GO..... \$1599.00/128K...\$1679.00
- MODEL 4 with 64K dual 40/40 track double density disk drives, complete systems with TRSDOS 6.0 and 1 BOX OF DISKETTES
PLUG IT IN AND GO..... \$1899.00/128K...\$1979.00
- MODEL 4 with 64K dual 80 track double density disk drives, complete systems with TRSDOS 6.0 and 1 BOX OF DISKETTES
PLUG IT IN AND GO..... \$1899.00/128K...\$1979.00
- MODEL 4 with 64K dual 80/80 track double density disk drives, complete systems with TRSDOS 6.0 and 1 BOX OF DISKETTES
PLUG IT IN AND GO..... \$2199.00/128K...\$2279.00
- MODEL 4 with 64K four 40 track double density internal disk drives, complete systems with TRSDOS 6.0 and 1 BOX OF DISKETTES
PLUG IT IN AND GO..... \$2299.00/128K...\$2379.00
- MODEL 4 with 64K four internal drives of any configuration available to achieve up to 4 meg of disk storage..... **CALL**
- MODEL III/4 Internal Two Drive Kit: Includes controller board, dual drive mounting bracket, dual power supply, all hardware cable; and connectors (gold plated) & TEC Drive..... **\$399.00**
- 4 DRIVE KIT MINUS DRIVE..... **\$349.00**
MODEL 100 8K..... **\$679.00** 24K..... **\$839.00**
- DV'S MODEL I DOUBLE DENSITY BOARDS..... **\$89.00**

WE CARRY TRS-80, IBM, LNW, EPSON & FRANKLIN COMPUTERS

Visit our retail location at:
**111 Marshall Street
Litchfield, MI 49252**
(313) 426-5086
(313) 482-4424
(517) 542-3280
(517) 542-3939
(517) 542-3947



**IMMEDIATE DELIVERY
DV'S SIX MONTH
PARTS AND LABOR WARRANTY**

Authorized Dealership at:
111 Marshall Street, Litchfield, Michigan 49252 P142
To Order, Call (313) 426-5086; (313) 482-4424; (517) 542-3280
(517) 542-3939; (517) 542-3947
OR WRITE:

Displayed Video, 111 Marshall St., Litchfield, MI 49252

*TRS-80 is a trademark of the Tandy Corporation

Prices subject to change without notice

Printer Cables

— Parallel —

\$35.00* ALTOS **\$35.00***
 ATTACHE
 ATARI
 CENTRONICS
 COLUMBIA
 EAGLE
 IBM-PC
 KAYPRO
 OSBORNE
 SANYO
 TI-99

FREE SHIPPING **FREE SHIPPING**

\$35.00* — SERIAL — **\$35.00***

ATTACHE COM.
 RS232 (DB25P)
 (9 conductor 1-8, 20)

WORSWICK INDUSTRIES

4030 Wabaska Dr.
 San Diego, CA 92107
 619-222-3366

*CA Residents Add 6% Sales Tax (\$2.34)

Circle 428 on inquiry card.

pc pipeline

Low, direct prices • Fast, direct service

2532-450..... \$4.25
 2716-450..... 3.20
 2732-450..... 3.99
 2764-250..... 7.15
 2764-350..... 4.79
 4164-200..... 4.50
 6116-P3..... 4.30
 6116-LP-3..... 4.50

Add \$2.95 shipping to all orders
 OEM • Quantity discounts available • P.O.s on approval • C.O.D. OK • Credit cards • FL residents add 5% tax • All new, no surplus, no seconds (Prices subject to change.)

4920 Cypress St., Suite 100, Tampa, FL 33607

In FL, and for info., call 813-875-0299

FOR ORDERS ONLY, 800-237-8910

8AM-5PM EDT



Circle 171 on inquiry card.

WANTED

Experienced hacker to work in development lab with every facility you can think of, located in Ft. Lauderdale, Florida.

The person we are looking for must:

Be familiar with CP/M at the BIOS Customization level.

Have some experience in microcommunications (programs like XMODEM and the like).

Be good at: - 8080 assembler
 - Microsoft BASIC
 - PASCAL

Hardware experience is desirable.

Equal Opportunity Employer M/F Handicapped

Please forward resumes to:
 Personnel Head, CLI,
 P.O. Box 821
 Pompano Beach, FL 33060

Circle 71 on inquiry card.



DOBERMAN

ATTENTION APPLE™ SOFTWARE DEVELOPERS

Put the bite on Software THEFT!

PROTECTS YOUR SOFTWARE IN 3 WAYS:

1. The Software Component
2. A Hardware "LOCK" that fits into your Games I/O
3. Our Security Database

• WON'T IMPED USE OF JOYSTICK OR PADDLES.
 • COMPATIBLE WITH DOS 3.3 • OPERATES WITH ALL TURKNEY PROGRAMS • PROTECTED DISKS WON'T BOOT WITHOUT A LOCK.



software research corporation

ONLY \$149.00

Order from SRC by mail or phone
 (604) 477-7246. We accept VISA,
 cash or COD orders.

DISCOVERY PARK
 UNIVERSITY OF VICTORIA
 P.O. BOX 1700, VICTORIA, B.C. CANADA
 V8W 2Y2

Circle 363 on inquiry card.

wabash

When it comes to Flexible Disks, nobody does it better than Wabash.

MasterCard, Visa Accepted.

Call Free: (800) 235-4137



PACIFIC EXCHANGES

100 Foothill Blvd.
 San Luis Obispo, CA
 93401 (In Cal. call
 (805) 543-1037)

Circle 299 on inquiry card.

ATTENTION BIG BOARD USERS! WHY USE OUTDATED TECHNOLOGY?

INSIGHT ENTERPRISES IS NOW DELIVERING A NEW STATE-OF-THE-ART CP/M Z80-A SINGLE BOARD COMPUTER



On board video • 128K of Dynamic RAM and 4K of STATIC (video memory) • DMA • SASI (hard disk interface) • Floppy disk controller (4 drives only combination of 5-1/4" or 8") • 4 serial ports • Full Centronics printer port • Expansion bus • Wide line and thin line graphics • Extended track buffer • Printer buffer • Fully interrupt driven • Parallel or Serial keyboard • Compact Size • (8 1/4 inches)

\$750.00 single quantity OEM pricing 2-4 weeks delivery \$10.00 shipping

INSIGHT ENTERPRISES CORPORATION

373 N. Western Ave., Suite 12 Los Angeles, CA 90004 (213) 461-3262

Dealer, OEM, International Inquiries Welcome
 MANUFACTURING LICENSES ARE AVAILABLE WORLDWIDE UPON REQUEST

Circle 204 on inquiry card.



FACTORY AUTHORIZED SALES & SERVICE

Wide choice of lease & lease/purchase plans
 Payments are example. Ask about other systems, boards, etc.

CompuPro
 SYSTEMS

Sys A \$103/mo., Sys B \$123/mo., Sys C \$160/mo., Sys D \$255/mo.

**MORROW DESIGNS
 DECISION 1**
 D120 \$110/mo., D200 \$117/mo., D210 \$130/mo., D220 \$155/mo.

Jarbell

Rebel \$78/mo., Rebel 16 meg \$103/mo., Rebel 16 meg multi-user \$124/mo.

Ask about bonus software. Accounting, games, utilities, PRINTERS, TERMINALS, SOFTWARE—CALL
 We cater to experienced users, gov't, agencies, and corp. customers.

TERMS: Cash with order
 You pay all freight. Add 5%
 for 2% (Other 20 AAA1 or
 Fed/State P.O. 2% /mo.
 carrying chg)
 CALL: US 9 AM to 10 PM
 205 879-5976
 205 879-4735

**CostPlus
 COMPUTERS**

P.O. Box 6114 • Birmingham, AL 35259-6114
 Our bank is 1st National of Birmingham. (205) 326-5120

Circle 117 on inquiry card.

APPLE HARDWARE

40% TO 70% OFF!!!

STOCK NUMBER	RETAIL PRICE	NOW ONLY	% OFF
AP101 16K RAM CARD	\$149	\$49	67%
AP102 80 COLUMN CARD	295	159	46%
AP104 CLOCK/CALENDAR CARD	195	89	54%
AP105 DISK-II DRIVE WO/CTRL	498	219	56%
AP106 DISK-II CONTROLLER	150	89	41%
AP107 JOY-STICK DELUX.	49	25	49%
AP108 LANGUAGE CARD ONLY	205	159	46%
AP109 LOWER CASE	45	25	49%
AP110 PRINTER CARD	150	59	61%
AP111 RS-232 CARD	195	89	54%
AP112 SUP-R-MOD	39	25	36%
AP114 Z-80 CARD	298	139	53%
AP115 DISK-II DRIVE WO/CTRL (SLIM LINE)	588	259	56%
AP116 INTEGER CARD	150	59	61%
AP117 EPROM WRITER CARD	279	139	50%
AP118 128K RAM CARD	498	279	44%
AP201 APPLE-II+ COMPAT 48K KIT	599	320	47%
AP202 HARDCARD FOR AP201	175	119	32%
AP203 KEYBOARD FOR AP201	139	78	44%
AP204 POWER SUPPLY FOR AP201	120	75	38%
AP401 IBM PC COMPUTER W/2 DRIVE	3550	2405	30%

WE ACCEPT C.O.D. PERSONAL CHECKS
 ALL PRICES GOOD THRU THE END OF THIS MONTH

K & R COMPUTER CO., LTD.
 1440 PACIFIC COAST HWY., #104
 HARBOR CITY, CA 90710
 (213) 530-2577

Circle 225 on inquiry card.

\$\$ Printers \$\$

\$\$ WE WILL NOT BE UNDERSOLD \$\$

EPSON

RX 80, MX 80FT, MX 100FT, FX 80 & newest
 FX 100 "lowest prices in the USA"

Gemini 10X..... \$329
 Gemini 15..... 494
 Prowriter 8510 (P)..... 385

All other printers discounted

Miscellaneous Hardware

Microsoft Premium Pack..... 479
 Microsoft Softcard..... 239
 Microsoft Softcard Plus..... 489
 (Includes video 80 Col.)
 Smartterm 80 Col..... 145
 Wizard 80 Col..... 179
 Video 80 Col. Combo..... 257

Printer Cards

Parallel..... 89
 Wizard Buffered BPO..... 149
 Grappier +..... 125
 Buffered Grappier +..... 209

THE COMPUTER STORE

3941-B S. Bristol Street
 Dept. 345
 Santa Ana, CA 92704
714-261-1383

ORDERS ONLY: (800) 824-2227

Circle 95 on inquiry card.

CABLES

ATARI PARALLEL	34.99
BASIS 108 PARALLEL	39.99
DTC	49.99
EPSON QX-10 PARALLEL	44.99
IBM PARALLEL	44.99
KAY PRO PARALLEL	34.99
MALE TO MALE RS232	24.99
OSBORNE PARALLEL	34.99
TI 99/4A PARALLEL	34.99

Novation

APPLE CAT II	295.99
APPLE CAT 212	
AUTO CAT 212	579.99
CAT	159.99
D-CAT	169.99
J-CAT	119.99
SMART CAT 103/212	459.99

BASIS

TWO DRIVES
128K 3.0 CP/M
 DIAGNOSTIC CONTROLLER
 CALL FOR LOWEST PRICES

SOFTWARE

BEAGLE BROS:	
ALPHA PLOT	24.99
APPLE MECHANIC	19.99
DOS BOSS	15.99
DOUBLE TIME	21.99
FLEX TEXT	19.99
PRONTO DOS	19.99
TYPEFACES	14.99
UTILITY CITY	19.99
BPI (GL,AP,AR,INV) ea.	299.99
BRODERBUND	\$Call
COPY II P.C. OR PLUS	29.99
DARK CRYSTAL	25.99
HOME ACCT (APPLE)	44.99
HOME ACCT (IBM)	99.99
HOME ACCT (OSBORNE)	59.99
MAGICALC	139.99
SCREEN WRITER II	89.99
STATE OF THE ART	\$Call
SUSPENDED (A,IBM)	29.99
VISICALC (APPLE)	169.99
VISICALC & CDEX (IBM)	179.99
VISIWORD & VISISPELL	\$Call
ZAXXON (AP, AT)	\$Call
ZORK I,II,III (A,IBM)	24.99

MONITORS

BMC 9191 12" Color	299.99
Taxan RGB I Color	319.99
Taxan RGB III Color	539.99
Taxan 12" Amber	134.99
Taxan 12" Green	129.99
USI 1400 12" Color	329.99
USI P11	99.99
USI P12	145.99
USI P13	149.99
USI P14	129.99

PRINTERS

BMC HR-1	749.99
BROTHER HR-1	799.99
DTC 380 Z	1195.99
EPSON (ALL MODELS)	\$Call
GEMINI 10	299.99
GEMINI 15	429.99
OKIDATA 82A	379.99
OKIDATA 83A	649.99
PROWRITER II	629.99

HARDWARE

ALS CPM 3.0	\$Call
APPLE EXT 80 COL CARD	219.99
BUFFER BOARD	139.99
DRIVE CONTROLLER	69.99
FINGERPRINT (MX-PLUS)	44.99
GRAPPLER+	119.99
HAYES SMARTMODEMS	\$Call
IN LINE MICRO BUFFER 32K	249.99
MICROBUFFER	129.99
MICROMODEM II	269.99
MICROMODEM II W/TP	299.99
MOCKING BOARD	\$Call
MONTECARLO CARD 64K	359.99
MX 80 RIBBONS	4.99
PARALLEL INTERFACE (APPLE)	69.99
PAYMAR L/CASE REV. 7	19.99
PKASO GRAPHICS CARD	139.99
PLANTRONICS COLOR CARD	
w/Draftsman Software (IBM)	389.99
SERIAL INTERFACE (A)	99.99
16K RAM CARD	39.99
SNAPSHOT TWO	99.99
SOFTCARD	239.99
USI RF MODULATOR	49.99
WILDCARD	109.99

MOUNTAIN COMPUTER

A/D - D/A	269.99
CABLES	\$Call
CLOCK	195.00
CPS CARD	159.00
EXPANSION CHASSIS	559.00
MUSIC SYSTEM	299.00
RAMPLUS 32K	145.00
ROMWRITER	145.00
SUPERTALKER	149.00

Videx

ENHANCER II	99.99
FUNCTION STRIP	56.99
PSIO	179.99
SOFTWARE	\$Call
ULTRATERM	\$Call
VIDEOTERM	199.99
VIDEOTERM w/ss & inv	229.99

KENSINGTON MICROWARE



SYSTEM SAVER

- Surge Suppression
- Dual Outlet
- U.L. Listed
- Fits Apple Stand

\$65

Verbatim

5 1/4" SS/DD/SS (100)	239.00
5 1/4" SS/DD/SS (10)	25.95
8" SS/DD/SS (10)	39.00
8" DS/DD/SS (10)	45.00

DRIVES

APPLE BRAND	299.99
4th DIMENSION	239.99
MICRO SCI A2	249.99
SUPER 5 DS/DD (IBM)	269.99

BOOKS

APPLE USERS GUIDE	12.99
BLUE BOOK (APPLE)	19.99
COMPUTER BUYERS GUIDE	15.99
SOFTWARE 1983 GUIDE (A, AT)	14.99

SATURN SYSTEMS

64K	279.99
128K	399.99
Accelerator	\$Call

GAME I/O

APPLE PADDLES	9.99
GAMEPORT III	69.99
KRAFT:	
JOYSTICK	47.99
JOYSTICK (AT, COM)	15.99
PADDLES	29.99
PADDLE-A-DAPPLE	24.99
PARADISE PORT	24.99
TG:	
JOYSTICK IBM:	45.99
JOYSTICK II	47.99
PADDLES	29.99
SELECT-A-PORT	47.99

SMITH-CORONA TP-1



\$499⁹⁹

QUADRAM

E-RAM (APPLE)	139.99
MICROFAZER	\$Call
QUADBOARD 64K	299.99
QUADBOARD 256K	499.99
QUADCHROME MONITOR	\$Call
QUADLINK	\$Call

POWER STRIP

W/SURGE PROTECTION

\$25⁰⁰

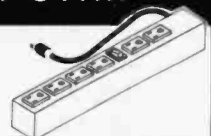

- No Charge for Credit Cards
- Prices Subject to Change Without Notice
- Min. \$4.00 Shipping Charge
- All Orders FOB San Jose
- Purchase Orders Welcome
- Call for Terms First



COMPUTER DISCOUNT PRODUCTS

MAIL ORDERS & RETAIL STORE
 860 S. Winchester Blvd.
 San Jose, CA 95128

(408) 985-0400

HOURS: MON-FRI 8AM-5PM - SAT & SUN 10AM-4PM

BREAKTHROUGH

300 bps **\$125** IMMEDIATE DELIVERY 1200 bps **\$310**

MODEMS • MODEMS • MODEMS

- UDS 103-O/ALP. 300 bps, full duplex, manual originate or answer modem
- UDS 212LP. 1200 bps, full duplex, manual originate or answer Modem
- Other models are available upon request



ORDER TODAY: 1-800-323-2666
or 312-459-8866

I.C.

Circle 432 on Inquiry card.

BEST BUYS ON DISKETTES LIFETIME GUARANTEE

ULTRA-Magnetics

Premium quality for absolute reliability and error-free performance. Individually tested. Meets or surpasses all industry specs.

- 5 1/4" SSDD Soft Sector w/hub rings \$1.79 in bulk \$1.49
- 5 1/4" DSDD Soft Sector w/hub rings \$2.79 in bulk \$2.39
- 8" and quad density also available.



SK

High quality/best price. Tested and certified to meet all industry standards.

- 5 1/4" SSDD Soft Sector w/hub rings \$1.69
- 5 1/4" DSDD Soft Sector w/hub rings \$2.59

Add 10% for quantities of less than 100.

Ask about volume discounts.

We also sell Blank Video Tapes at wholesale prices.

CALL TOLL FREE (800) 982-2244

8 AM-7 PM Mon-Fri, 8 AM-12 PM Sat
Checks, Money Order, Visa, MasterCard—5% shipping,
California Residents add 6 1/2% Sales Tax.

VIDIOM MEDIA SUPPLY, INC.

500 Airport Boulevard, Suite 422
Burlingame, California 94010
415 342-0663 (anytime)

Circle 413 on Inquiry card.

\$\$ Printers \$\$

\$\$ WE WILL NOT BE UNDERSOLD \$\$

Special Sale

Communications Pak

Hayes Smartmodem 300/1200	\$499
Hayes Micromodem II	279
Apple Cat II	282
J Cat	129
Anchor Mark I RS232	89
Anchor Mark VII aul.	139

DISK DRIVES

Rana Elite I	289
Rana Elite II	435
Rana Elite III	575
Rana Controller w/drive	75
Apple Ace Mate (1 yr. warr.)	239
Slim Teac 5 1/4" (1 yr. warr.)	269

THE COMPUTER STORE

Dept. 345
3941-B South Bristol St.
Santa Ana, CA 92704
714-261-1383

ORDERS ONLY: (800) 824-2227

Circle 98 on Inquiry card.

BATTERY BACKUP 32K CMOS RAM/EPROM S-100 MEMORY BOARD 8 or 16 BIT DATA PATH \$279 A&T

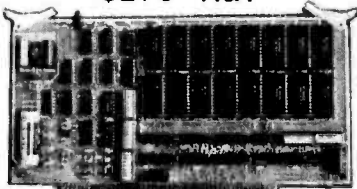

- ◆ 6MHZ
- ◆ phantom option
- ◆ IEEE 898 (S-100) compatible
- ◆ extended addressing switch selectable
- ◆ all address and data lines are buffered
- ◆ window selection at 2K boundary
- ◆ EPROM can be mixed with RAM
- ◆ bank select
- ◆ activity indicator

Yang Electronic Systems, Inc.

307 Compton Ave. Laurel, Maryland 20707
(301) 776-0076

Circle 431 on Inquiry card.

BIG SALE

CALL . . . GOODWILL ELECTRONICS CO.

APPLE HARDWARE

Stock Number	Description	Price
AW 101	48K Compact computer (Keyboard & Hardware)	\$473
AW 102	Disk drive w/out Controller	249
AW 103	Gemini 10 Printer	755
AW 104	12" Green monitor	105
AW 201	80 Column card	120
AW 202	Z-80 card	129
AW 203	Disk-II controller	85
AW 204	Termmodem (RS-232)	75
AW 205	16K RAM card (Language)	49
AW 206	Personal card	58
AW 207	APLS keyboard	78
AW 208	Joy-stick device	28
AW 209	Sup-R-Mod	78
AW 210	Power-Supply for AW 101	75

We accept Visa, MasterCard, checks and G.O.D. CA residents add 6 1/2% Tax.
Shipping \$3.00 for first 3 lbs. 40¢ for each additional.

GOODWILL ELECTRONICS CO.

16901 CRENSHAW BLVD
TORRANCE, CA 90504
(213) 532-9624

Circle 187 on inquiry card.

INVENTORY REDUCTION

EAGLE III MICROCOMPUTER —
64K, CP/M; includes spellbinder, ultra-
calc, CPM C basic \$2,495.00*

MANNESMANN TALLY 1805
dual mode printer, 200 CPS
draft mode/50LPS
correspondence mode \$1,395.00*

DATAVUE DISPLAY TERMINALS —
132 & 80 column formats, soft keyboard
originally \$1,995.00*
now \$1,000.00

TELEVIDEO 950 —
demo units \$ 850.00*

ECONOMY PERIPHERALS, INC.

Call (404) 952-0213

* WHILE QUANTITIES LAST

Circle 157 on Inquiry card.

Verbatim flexible disks

Call Free (800) 235-4137 for
prices and information. Dealer
inquiries invited. C.O.D. and
charge cards accepted.

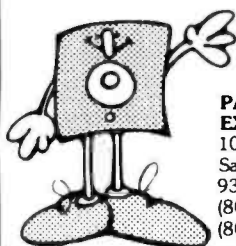

**PACIFIC
EXCHANGES**
100 Foothill Blvd.
San Luis Obispo, CA
93401. In Cal. call
(800) 592-5935 or
(805) 543-1037.

Circle 299 on Inquiry card.

GLoucester COMPUTER

PQ/64, all features of Promqueen less mimic mode.
Software enhanced to include EPROM QC utilities, RS-
232 communication, printouts. 28 pin ZIF socket.

Reads, edits runs and
programs all 5 volt
2500 and 2700 series
EPROMS plus variety
of EEPROMS all with-
out personality mod-
ules. Commodore C-
64 host computer.
Inquire about the
mimic mode capabil-
ity in our VIC Promqueen.

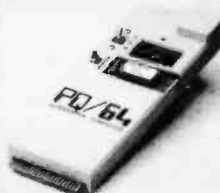

\$299.00

ROM Packs Industrial quality circuit cards are
socketed, solder masked, fully bypassed, and in-
clude a ground plane for low noise operation. In-
cludes 1 EPROM. 8K & 16K models for VIC-20 and
C-64. Specify 2732 or 2764 EPROM type. Molded
plastic case. **\$39.00**

GLoucester COMPUTER
1 Blackburn Center, Gloucester, MA 01930 617-283-7719

Circle 183 on Inquiry card.

300 BAUD	MODEMS	1200 BAUD
SIGNALMAN. . . with cables, free hour on 'SOURCE'		
300 BAUD direct connect		\$ 69
300 BAUD AUTO DIAL/ANS		\$119
300/1200 AUTO DIAL/ANS		\$319
Hayes Compatible		
US ROBOTICS 'Hayes Compatible'		
300/1200 AUTO DIAL/ANS		
'Password' with cables, spk r		\$339
'Auto 212' dixe		\$419
DOT MATRIX PRINTERS LETTER QUALITY		
GEMINI 10x 120 cps graphics		\$319
PROWRITER 120 cps hi density		\$389
JUKI daisy wheel 18 cps		\$589
SILVER REED wide carriage 18 cps		\$689
CP/M COMPUTERS IBM		
Eagle II	SCALL	Columbia P.C.
Televideo		Corona P.C.
		Eagle P.C.
IMAGE COMPUTERS		
P.O. Box 1164, Cardiff, CA 92007		
CALL TO ORDER:		
619 436-7669		VISA/MC
619 436-8317		ADD 3%

Circle 201 on Inquiry card.

wabash[®] diskettes \$1.39 each!

for
as
low
as

Now...Get High Quality at a Low Price

Wabash means quality products that you can depend on. For over 16 years, Wabash has been making high quality computer products. Wabash diskettes are made to provide error-free performance on your computer system. Every Wabash diskette is individually tested and is 100% certified to insure premium performance.

Why Wabash is Special

The quality of Wabash diskettes is stressed throughout the entire manufacturing process. After coating, all Wabash diskettes go through a unique burnishing process that gives each diskette a mirror-smooth appearance. Wabash then carefully applies a lubricant that is specially formulated to increase diskette life. This saves you money, since your discs may last longer. It also assists your disk drives in maintaining constant speed which can reduce read and write errors.

Special Seal...Helps Prevent Contamination

To keep out foreign particles, a unique heat seal bonds the jacket and liner together. A special thermal seal which avoids contamination from adhesives, is then used to fold and seal the jacket. This results in outstanding performance and true reliability. Wabash then packages each diskette, (except bulk pack) in a super strong and tear resistant Tyvek[®] envelope. The final Wabash product is then shrink-wrapped to insure cleanliness and reduce contamination during shipment.

Each Diskette is 100% Critically Tested

Since each step in the Wabash diskette manufacturing process is subject to strict quality control procedures, you can be sure Wabash diskettes will perform for you. And every Wabash diskette meets the ultra-high standards of ANSI, ECMA, IBM and ISO in addition to the many critical quality control tests performed by Wabash. Wabash does all of this testing to provide you with consistently high quality diskettes. Reliability and data integrity - that's what Wabash quality is all about.

Flexible Disc Quantity Discounts Available

Wabash diskettes are packed 10 discs to a carton and 10 cartons to a case. The economy bulk pack is packaged 100 discs to a case without envelopes or labels. Please order only in increments of 100 units for quantity 100 pricing. With the exception of bulk pack, we are also willing to accommodate your smaller orders. Quantities less than 100 units are available in increments of 10 units at a 10% surcharge. **Quantity discounts** are also available. Order 500 or more discs at the same time and deduct 1%; 1,000 or more saves you 2%; 2,000 or more saves you 3%; 5,000 or more saves you 4%; 10,000 or more saves you 5%; 25,000 or more saves you 6%; 50,000 or more saves you 7% and 100,000 or more discs earns you an 8% discount off our super low quantity 100 price. Almost all Wabash diskettes are immediately available from CE. Our warehouse facilities are equipped to help us get you the quality product you need, when you need it. If you need further assistance to find the flexible disc that's right for you, call the Wabash diskette compatibility hotline. Dial toll-free 800-323-9868 and ask for your compatibility representative. In Illinois or outside the United States dial 312-593-6363 between 9 AM to 4 PM Central Time.

Circle 78 on Inquiry card.

SAVE ON WABASH DISKETTES

Product Description	Part #	CE quant. 100 price per disc (\$)
8" SSSD IBM Compatible (128 B/S, 26 Sectors)	F111	1.99
8" Same as above, but bulk pack w/o envelope	F111B	1.79
8" SSSD Shugart Compatible, 32 Hard Sector	F31A	1.99
8" SSDD IBM Compatible (128 B/S, 26 Sectors)	F131	2.49
8" DSDD Soft Sector (Unformatted)	F14A	3.19
8" DSDD Soft Sector (256 B/S, 26 Sectors)	F144	3.19
8" DSDD Soft Sector (512 B/S, 15 Sectors)	F145	3.19
8" DSDD Soft Sector (1024 B/S, 8 Sectors)	F147	3.19
5 1/4" SSSD Soft Sector w/Hub Ring	M11A	1.59
5 1/4" Same as above, but bulk pack w/o envelope	M11AB	1.39
5 1/4" SSSD 10 Hard Sector w/Hub Ring	M41A	1.59
5 1/4" SSSD 16 Hard Sector w/Hub Ring	M51A	1.59
5 1/4" SSDD Lanier No-problem compatible	M51F	2.99
5 1/4" SSDD Soft Sector w/Hub Ring	M13A	1.89
5 1/4" Same as above, but bulk pack w/o envelope	M13AB	1.69
5 1/4" SSDD Soft Sector Flippy Disk (use both sides)	M18A	2.79
5 1/4" SSDD 10 Hard Sector w/Hub Ring	M43A	1.89
5 1/4" SSDD 16 Hard Sector w/Hub Ring	M53A	1.89
5 1/4" DSDD Soft Sector w/Hub Ring	M14A	2.79
5 1/4" DSDD 10 Hard Sector w/Hub Ring	M44A	2.79
5 1/4" DSDD 16 Hard Sector w/Hub Ring	M54A	2.79
5 1/4" SSQD Soft Sector w/Hub Ring (96 TPI)	M15A	2.69
5 1/4" DSQD Soft Sector w/Hub Ring (96 TPI)	M16A	3.79

SSSD = Single Sided Single Density; SSDD = Single Sided Double Density;
DSDD = Double Sided Double Density; SSQD = Single Sided Quad Density;
DSQD = Double Sided Quad Density; TPI = Tracks per inch.

Buy with Confidence

To get the fastest delivery from CE of your Wabash computer products, send or phone your order directly to our Computer Products Division. Be sure to calculate your price using the CE prices in this ad. Michigan residents please add 4% sales tax or supply your tax I.D. number. Written purchase orders are accepted from approved government agencies and most well rated firms at a 30% surcharge for net 30 billing. All sales are subject to availability, acceptance and verification. All sales are final. Prices, terms and specifications are subject to change without notice. All prices are in U.S. dollars. Out of stock items will be placed on backorder automatically unless CE is instructed differently. Minimum *prepaid* order \$50.00. Minimum *purchase* order \$200.00. International orders are invited with a \$20.00 surcharge for special handling in addition to shipping charges. All shipments are F.O.B. Ann Arbor, Michigan. No COD's please. Non-certified and foreign checks require bank clearance.

For shipping charges add \$8.00 per case or partial-case of 100 8-inch discs or \$6.00 per case or partial-case of 100 5 1/4-inch mini-discs for U.P.S. ground shipping and handling in the continental United States.

Mail orders to: Communications Electronics, Box 1002, Ann Arbor, Michigan 48106 U.S.A. If you have a Master Card or Visa card, you may call and place a credit card order. Order toll-free in the U.S. Dial 800-521-4414. If you are outside the U.S. or in Michigan, dial 313-994-4444. Order your Wabash diskettes from Communications Electronics today.

Copyright ©1982 Communications Electronics™

Ad #110582



Order Toll-Free!
800-521-4414
In Michigan 313-994-4444

wabash
error-free
diskettes

COMMUNICATIONS
ELECTRONICS™

Computer Products Division

854 Phoenix □ Box 1002 □ Ann Arbor, Michigan 48106 U.S.A.
Call TOLL-FREE (800) 521-4414 or outside U.S.A. (313) 994-4444

BYTE August 1983 541

IBM ← digital

PC-LINK DEC VT100[®] TERMINAL EMULATOR

- A full featured DEC VT100[®] terminal emulator on IBM PC.
- Transfer text files between host and PC.
- Very easy to learn! All DEC softwares can be accessed from IBM PC. You can use the standard DEC editor ed on PC without learning the intricacies of escape sequence.
- To use PC-Link program, the PC needs to have at least one disk drive, IBM DOS, IBM monochrome display, a RS232 port and telephone modem.
- \$40.00/10 day money-back guarantee with all materials returned.

Add \$5.00 for shipping

SCREENWARE CORPORATION
P.O. BOX 3662
NASHUA, NH 03061-3662
Tel. 603-888-4074



Circle 491 on Inquiry card.

Scotch[®] Diskettes

Rely on Scotch[®] diskettes to keep your valuable data safe. Dependable Scotch diskettes are tested and guaranteed error-free. The low abrasivity saves your read/write heads. They're compatible with most diskette drives.



(800)235-4137



Dealer Inquiries
Invited

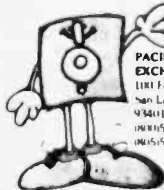

PACIFIC EXCHANGES
1181 Franklin Blvd.
San Luis Obispo, CA
93401 In Cal call
(805)92-5945
(805)54-1117

Circle 299 on Inquiry card.

TeleCOMM[™] - A Complete Versatile, User-friendly & Telecommunicating

ELECTRONIC MAIL PROGRAM

TeleVideo[®], CP/M[®], MP/M[™], TurboDOS[™] based Computers.
TeleCOMM Provides you with the most efficient and cost-effective means of communicating between you and your branch offices, coworkers, friends or family via a local area network or nationwide telephone link.

- Multi-Single user Computers
- Password Protected Transactions
- Broadcasting and Forwarding
- Totaly Menu-driven Functions
- Versatile Printing
- Unlimited Undo Commands
- Screen Editing
- Modern Interfaces
- Unlimited Users
- Send Letters/Messages/Programs
- Full Screen Editing
- Date: Month/Day/Year
- Automatic Prompt for Incoming Mail
- Interactive Video Attributes (TeleVideo)

Listed Price: \$498

Special Introductory Price: \$280

TeleWORD[™] - WORD PROCESSOR

- CP/M Based & Modern Interfaces
- Built-in Operating System Commands
- Password Protected Transactions
- Flexible Document Formats
- Customer Processing
- Document Assembly and Merge
- Unlimited Undo Commands
- Screen Editing
- Prompt for Incoming Electronic Mail
- Fully Menu-driven Functions
- Horizontal and Vertical Scroll
- Automatics and Indentations
- Calculator Mode
- Making Lists & Labels/Envelope Printing
- Block Move and Delete

Special Introductory Price: \$98

TurboDOS[™] - Free Consulting & Demo, Customized Drivers.
Multiuser: \$498

TeleHOST[™] - Allows your terminal/computer to communicate with other computers via telephone links. Price: \$98

TeleLIST[™] - Mailing List Program, Prints Labels. Price: \$75



International Computers & Telecommunications, Inc.
932 Hungerford Drive, 16-B, Rockville, MD 20850
13011 251-0062

Circle 205 on inquiry card.

Smith-Corona TP-1 Daisy Wheel Printer

only \$469⁰⁰

UNBELIEVABLE!

- Fully-formed characters
- compatible with most micro-computers
- Serial or parallel interface
- choice of 10 or 12 CPI models

Also for your TP-1 letter quality printer -
the Smith-Corona Tractor Feed

\$1349⁵

- Adjustable tractor widths
- For continuous forms
- Quick, easy removal



Call Collect
(214) 826-6521

FIGURE-LOGIC BUSINESS EQUIPMENT, INC.
6408 Gaston Avenue / Dallas, Texas 75214

Circle 492 on Inquiry card.

Serial ← → Parallel



PRINTERS!
PLOTTERS!
PUNCHES!
ROBOTS!

Convert What You Have
To What You Want!

- RS232 Serial
- 8 Baud Rates
- Latched Outputs
- Centronics Parallel
- Handshake Signals
- Compact 3 1/2" x 4 1/4" x 1 1/2"

No longer will your peripheral choices be limited by the type of port you have available! Our new High Performance 700 Series Converters provide the missing link. Based on the latest in CMOS technology, these units feature full baud rate selection to 19.2K, with handshake signals to maximize transfer efficiency. Detailed documentation allows simplified installation. Order the Model 770 (SerialPar) or Model 775 (ParSer) Today!

Butler Products
Coming Soon!

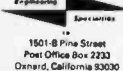

only \$89.⁹⁵

Connector Option \$10.00
CA Residents 6% tax
UPS Shipping \$3.00

CALL (805) 487-1885 or 487-1666

For FAST Delivery

Circle 163 on Inquiry card.

ADDS VIEWPOINT \$550.00

INTRODUCING THE

PRO-100
COMPUTER

ONLY
\$1995
COMPLETE

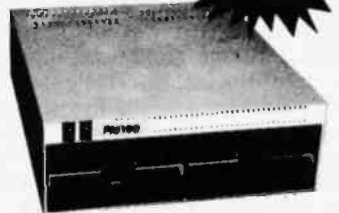

SINGLE BOARD COMPUTER • 280A • 64KRAM • 2 SERIAL PORTS • 1 CENTRONICS PORT • SYSTEM TEST FROM TWO 8" DISK DRIVES • CP/M[®] COMPATIBLE • SUPER FAST DISK ACCESS • 32K SOFTWARE SPOOLER • DIGITAL PHASE LOCK LOOP • WORKS IN EITHER IBM STANDARD SD OR DD • OEM AND PRIVATE LABELS AGREEMENTS ARE AVAILABLE • DEALER DISCOUNTS.

MANUAL & SCHEMATICS	\$ 35	CYBERTEK CORP.
BOARD KIT	\$300	P.O. Box 1913
CHASSIS KIT	\$300	Hialeah, FL 33011-1913
CPM + BIOS	\$150	Tel. (305) 386-4750

Circle 184 on Inquiry card.

NOW MAKE SOLID
CONNECTIONS....
Male or Female

RS 232 GENDER REVERSERS

\$19.95 each

American Made



Order either
two male or two
female connectors with

all 25 pins inter-connected. Both Gender Reversers just \$34.95, plus \$1.75 shipping & handling, (IL res. add 5% sales tax); we accept MC or VISA.

Ask for FREE illustrated catalog of problem solving equipment.
Phone: 815-539-5827.
Make checks payable to:



B&B electronics

P.O. Box 475B • Mendota, IL 61342

Circle 493 on Inquiry card.

ScreenWiz FULL SCREEN CONTROL

An assembler subprogram you call from your programs to handle screen input/output as IBM mainframes do.

Define full screen format specifications outside your program, and call ScreenWiz to retrieve the formats, and do all the I/O for you.

- One command INPUT/DISPLAYS a full screen
- Use all of your CRT video attributes
- Define up to 24 function keys
- Define templates for display and input.
- Validate input while keying. Insert and delete characters to correct fields
- Tab fields forward and backward
- Draw figures using vertical field displays
- Save memory as only one format needs to be in memory at one time. Make the constants to display virtual, and they don't use any memory at all.
- Build help screens. Call them with one function key then return to where you were.

Available now for most popular -

BASIC	IBM PC and CP/M	\$99
COBOL	Apple II CP/M	\$75
FORTRAN	Shipping	\$ 4
PASCAL	Source code included	

Dealer inquiries welcome

INTERDATA SYSTEMS INC.
42 Ellinforde, Toronto, Ont. Canada M2J 1B5 Visa, M/C
(416) 493-8675 (call collect to order) Am. Express

Circle 213 on Inquiry card.

Floppy Disks & Printer Ribbons

Scotch[®]
MEMOREX
Dysan CORPORATION
BEST PRICES IN THE U.S.
Dealer Inquiries Invited • C.O.D. Accepted
TOLL FREE 800-652-8168
CALIF. 213-706-1626



5015 Kanan Road
Agoura Hills, CA
91301

Circle 494 on inquiry card.

**TOLL-FREE
ORDERING:
800-222-8686**

**FOR TECHNICAL SUPPORT/
SERVICE / IN ARIZONA:
602-282-6299**

CCT CUSTOMER COMPUTER TECHNOLOGY

1 CRAFTSMAN COURT — BOX 4160 — SEDONA, ARIZONA 86340

Purchase your Hardware and Software directly from an OEM/Systems Integrator. Take advantage of our buying power! We stock a full line of Board Level Components, Software, and Peripherals. Call for your needs. We'll give you the Lowest Prices, and the Technical Support and Know-How we are quickly becoming well-known for. Satisfied Customers Nationwide! The Nations's Custom Systems House for Business, Education and Science. Call for a system quote.

• FOREMOST QUALITY • ADVANCED SUPPORT • REASONABLE COST •

OF PRIME INTEREST

Our prime interest at CCT is **service and support**. We build and sell hundreds of systems per year to the serious computer market. We rigidly adhere to our strict policy of reliable machines, and reliable people behind them. We feel the CompuPro product line to be the state-of-the-art of the computer industry.

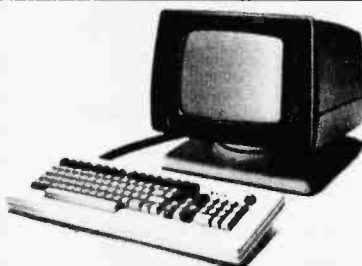

**PROFESSIONAL LEVEL BUSINESS SYSTEMS
STATE-OF-THE-ART QUALITY, PERFORMANCE, RELIABILITY**

THE CCT EXCLUSIVE WARRANTY

With any system we build, we provide, in writing, an unconditional 12 month **direct** warranty on the entire system, including mainframe, boards, drives, power supplies, cabling and peripherals! We offer guaranteed 24 hour in-house repair and/or replacement with just a toll-free phone call. We can offer this, since we are so sure of our level of quality and reliability. It's great to know that in the event of a problem, you're not out of business waiting on service turnaround. We deliver!

Our various OEM contracts with all the manufacturers of the components we integrate, allow us this unprecedented flexibility. No factory O.K.'s necessary — just get it running — **NOW!**

Wyse 100 terminal \$769.
Mitsubishi 8" DSDD drives, full or half height \$449.
Okidata 82 \$419 / 83 \$679
84 .. \$1029 / 92 .. \$559 / 93 .. \$930
Ashton-Tate dBASE II \$459
Hays Modem-\$259 • Diablo 620-\$1029

MORROW MICRO DECISION

IN STOCK! **CCT TESTED!**
1 Drive - \$899 • 2 Drive - \$1249
Morrow Terminal - \$499

Our in-house cabling Department has cables in stock for all CompuPro boards, drives, power supplies, printers, terminals and modems. The highest quality — at reasonable prices.
RS-232 Cable: \$25

TECH TIP CORNER

"CompuPro CP/M86 — Replace that bothersome Control-S with the space bar! Use DDT86, change location 144A from 13 to 20 Have fun — Pat...

CCT ANNOUNCES: OUR OWN IN-HOUSE ENGINEERED CCT-1 — ENTRY LEVEL S-100 BUSINESS SYSTEM

Enclosure 2-Desk-20 Slot Mainframe
CPU 8085/88 - 6Mhz 8085/8Mhz 8088
Disk 1 - DMA Floppy Disk Controller
RAM 17 - 64K Static RAM - 12 Mhz
Interfacer 4 - 3 Serial/2 Parallel I/O

CCT Dual 8" Mitsubishi
DSDD Drive System - 2.4 Megabytes
CP/M 80 - 2.2 LD/M - CCT Modified
All Cabling, Complete CCT Assembly,
Testing, and minimum 20 Hour Burn-in

**INTRODUCTORY PRICE:
\$3,559**

RUNS ALL STANDARD 8" CP/M SOFTWARE - INCLUDES OUR EXCLUSIVE 12 MONTH DIRECT WARRANTY

CP/M MP/M NOTE: Each copy we furnish is CCT modified for the target system. M-Drive/H and hard disk drivers are furnished, and the BIOS optimized for the fastest disk step rate, as well as terminal and printer compatibility.

★ ★ CCT-2 ★ ★ COMING SOON ★ ★ WATCH THE FAST LANE FOR THIS ONE ★ ★

Designed for large users, complex programmers, and program intensive applications.

THE FASTEST MICROCOMPUTER IN THE WORLD!!

16 Bit • 10 Mhz+ • M-Drive/H • I/O mapped on-the-bus terminal • Ultra-fast disk!

Unreal speed — Leaves the rest of the world at the starting line

We are the largest in the custom configuration of complete state-of-the-art S-100 systems, at package pricing, with integration, burn-in and programming. We custom build CompuPro systems / hard disk systems for business applications. Call for CompuPro literature, CCT system configuration data and technical information.

COMPUPRO COMPONENTS

LIMITED SPECIALS: **System 816A-\$4395** **System 816B-\$5595** **System 816C-\$7195** **Call for other systems**
M-Drive CP/M w/RAM Purch-\$49 • Disk 1w/CP/M-\$449 • M-Drive/H-512K-\$1399
CPU 8085/88-\$379 • CPU 8086/87-\$579/10Mhz-\$659 • CPU 68K-\$519/10Mhz-\$639 • CPU-Z -\$249
Disk 1-\$369 • Disk 2-\$599 • Disk 2BE-CALL! • Disk 3-SOON!
RAM 17 (12MHZ)-\$359 • RAM 16 (12MHZ)-\$399 • RAM 21 (128K)-\$849 • RAM 22 (256K)-\$1899
Interfacer 1 - \$229 • Interfacer 2-\$249 • Interfacer 3-5-\$459/3-8-\$539 • Interfacer 4-\$349
System Support 1-\$349 • Enclosure 2-Desk-\$659/Rack-\$699 • 20 Slot Motherboard-\$210
CP/M 80-\$99 • CP/M 86-\$179 • MP/M 8-16-\$769 • CP/M 68K-\$279 • Forth 68K-\$169

Call for CSC Boards — New Releases — Operating System Mods/Updates

? ? HARD DISK DECISIONS ? ?

24 Megabyte hard/floppy

CCT/Fujitsu/Mitsubishi ultra-system: 23 meg. hard disk next to 1.2 meg. 8" DSDD floppy drive. Includes disk 2 board set, all cabling, A&T, formatting, burn-in. Will stand alone in any CompuPro system.

\$3699

23 Megabyte subsystem

CCT/Fujitsu 23 megabyte hard disk subsystem. Includes disk 2 board set, all cabling, A&T, formatting, burn-in. Ready for any CompuPro system:

\$3199

2.4 Megabyte floppy system

CCT/Mitsubishi 2.4 megabyte dual DSDD 8" system. Includes all cabling, A&T, burn-in. This is the fastest system available:

\$1149

Prices & availability subject to change. All products new, and carry full manufacturer's warranties. Call for catalog. Free technical help to anyone. We can configure boards & software for your system. Plug-in and go. Arizona Residents add sales tax.

CompuPro Trademark — W.J. Godbout; CP/M MP/M Trademarks — Digital Research

We're Flooding The Market

MINIMUM SHIPPING \$3.00 - NO SURCHARGE ON VISA/MASTERCHARGE

1-800-545-2633 - Continental U.S.

DISK DRIVES

SHUGART	
5 1/4" SA400 (35 TR)	150.00
5 1/4" SA400L (#0 TR)	175.00
8" SA801R(SS/DD)	359.00
8" SA851R(DS/DD)	479.00
QUME	
8" DT8 (842)	490.00
MITSUBISHI	
5 1/4" M-4851 1/2 size DS/DD 40TR	295.00
5 1/4" M-4853 1/2 size 96 TPI same as TM 100-4	410.00
5 1/4" M-4854 1/2 size 1.6 MG w/8" electronics formats same as IBM 1 & 2D 8" std	439.00
8" M-2894-63 (110V) STD 8" DS/DD 1.2 MG	399.00
M-2894-63(SS/DD) 220V	449.00
8" M-2996-63	439.00
Thinline 8" DS/DD 1.2 MG	

SHUGART 800/801R RECONDITIONED	
90 Day Warranty	160.00
TANDON	
5 1/4" TM100-1 SS/DD	195.00
5 1/4" TM100-2 FOR IBM DS/DD	239.00
8" TM848-2 (DS/DD)	425.00
PERTEC	
5 1/4" FD200-S SS/DD 40TR	139.00
5 1/4" FD250-S DS/DD 40TR	195.00
SIEMENS	
8" FD100-8 (SS/DD) 110V	179.00
8" FD100-8 (SS/DD) 220V	199.00
MPI	
5 1/4" B-51 40TR SS/DD	195.00
5 1/4" B-52 FOR IBM 80TR DS/DD	250.00

DISK DRIVE CABINETS

8" CABINETS

*NOTE-Power supply will accommodate hard disk

8" *DCC88V28 w/PS vertical-for 2-8" drives	300.00
8" DCC88T-1 w/PS vertical-for 2 or 4-8" thinline drives	300.00
8" DCC88T-2 w/PS vertical-inexpensive version for 2-8" thinline drives	225.00
8" *DCC8V w/PS vertical-for 1-8" drive	249.00
8" *DCC88H w/PS horizontal-for 2-8" drives	300.00

5 1/4" CABINETS

5 1/4" DDC5H w/PS horizontal-for 1-5 1/4" drive	59.00
5 1/4" DDC55H w/PS vertical-for 2-5 1/4" drives	89.00

AC SURGE ELIMINATORS

Lemon (6AC outlets - 3 prong) 46.00	Orange - AC surge + EMI filter (6 outlets) 119.00
Lime (5' - 3 prong pwr cord w/on-off switch) 69.00	Plum - EMI-RF filter 39.00

DISKETTE STORAGE

ADVANCE ACCESS	
AA-5 1/4" (Holds 82 Disks)	19.00
AA-8 (Holds 82 Disks)	26.00
Smoked Plexiglass Disk Tubs	
LIBRARY CASES	
CAS-5 1/4" "	2.50
CAS-8" "	3.00
Colors Available: color burst asst., beige, black, blue, red, gray	

DISKETTES

COLOR CODE YOUR FILES
Diskettes by 3M with lifetime warranty, 5 colors. Prices are for package of 10.

5 1/4" Sgl side/sgl den	19.00/10
5 1/4" Sgl side/dbl den	20.00/10
5 1/4" Dbl side/dbl den	26.00/10
5 1/4" 10 sector	22.00/10
5 1/4" 16 sector	22.00/10
8" Sgl side/dbl den	29.00/10
8" Dbl side/dbl den	36.00/10

DISK DRIVES

FOR APPLE AND FRANKLIN MICRO-SCI

A-2 (SS/DD)	229.00
A-40 (DS/DD)	279.00
A-70 (Quad Density)	359.00
Controller	70.00
RANA SYSTEMS	
Elite I (SS/DD)	269.00
Elite II (DS/DD)	429.00
Elite III (Quad-Density)	539.00
Controller	70.00

VIDEO DISPLAY MONITORS

USI	
PI-1 (9" Amber Hi-Res)	139.00
PI-2 (9" Green Hi-Res)	129.00
PI-3 (12" Amber Hi-Res)	149.00
PI-4 (12" Green Hi-Res)	139.00
SANYO	
DM5109 (9" Green)	89.00
DM2112 (12" Green) 15MHz	84.00
BMC	
BMC 12 AU (12" Green)	79.00
BMC 9191 Color Composite	269.00
AMDEK	
Color I and w/sound	299.00
Color II RGB	569.00
Color III RGB	399.00

DATA CABLES

8" DSC 88-2SKT-for 2-8" drvs w/sk1. conn.	16.95
5 1/4" DSC55-2SKT-for 1-5 1/4" dvs w/sk1. conn.	15.00
RS232MM-5" (male to male)	19.00
IBM to PAR	32.00
Osborne to PAR	32.00
Kaypro to PAR	32.00
OKI-Data Serial	24.00

MODEMS

Hayes Smart 300	199.00
Hayes Smart 1200	499.00
Novation J-Cat 300	119.00
Novation Apple Cat II	269.00

PARTS

TR1802B	2.90 ea.	TMS2165 (+12v)	\$3.95 ea.
2114L2	\$1.50 ea.	TMS2732	\$4.95 ea.
TMS2532	\$5.95 ea.	TMS4184(200NS)	\$5.95 ea.
2716 (SV)	\$3.95 ea.	TMS116-4000NS)	\$4.75 ea.

MANY OTHERS IN STOCK

E-PROM ERASERS

QUV-T8/1 (hobby)	49.95
QUV-T8/2 (Industrial version)	68.95
QUV-T8/2 (w/Timer & safety switch)	97.50

CONNECTORS

RS232 Connectors		FLAT RIBBON TYPE	
DB25P	2.50	IDC35P	6.25
DB25S	3.00	IDC25S	6.90
DB25 Hood	1.00	IDC25 Hood	1.80
S-100 Connectors	1.00	10 for 25.00	

SOFTWARE

ASHTON-TATE D-BASE II	\$409.00
-----------------------	----------

S-100 PRODUCTS

GIGANTIC REDUCTIONS IN PRICE!

CARD CAGES/MOTHER BOARDS

*IEEE-696-No termination required

Slots	Bare Bd	A + T	w/card cage	bare card cage
4	15.00	40.00	60.00	20.00
6	20.00	48.00	70.00	22.00
8	25.00	69.00	100.00	31.00
12	30.00	99.00	140.00	41.00
18	45.00	150.00	200.00	50.00
22	60.00	185.00	—	75.00

All card cages will accommodate a 4" fan
Add \$20.00 for 1 fan-Add \$30.00 for 2 fans

MAINFRAMES

For 2 Standard 8" Drives

MF+DD6 (6 slot M/B)	699.00
MF+DD8 (8 slot M/B)	749.00
MF+DD12 (12 slot M/B)	799.00

For 2 Thinline 8" Drives

IMF+DD6C (Cadillac version)	500.00
IMF+DD6F (Ford version)	350.00

For 2 - 5 1/4" Disk Drives

MF+MD12 (12 slot M/B)	575.00
-----------------------	--------

Standard Plain Front

MF+12 (12 slot M/B)	500.00
MF+22 (22 slot M/B)	600.00

All mainframes except IMF+DD6F have EMI filter, 2 AC outlets, 15 ea. DB25, 2 ea. 50 pin, 2 ea. 34 pin, 1 ea. Centronic cutouts, power supply for 8" MF (-5V1A/+5V6A/+8V16A/±16V3A/+24V6A)

SIERRA DATA

SDS SBC-100-280(mhz) master	
2 serial 2 part/floppy controller/84k ram	\$455.00
SDS SBC-100S-4mhz serial/2 serial	\$565.00
2 serial/4k ram	\$235.00
SDS ZS-10/4-4 serial port I/O bd	\$235.00
SDS MUX RS232 multiplexer bd	\$125.00
SDS-HDI-M-Hard disk bd for microdisks	\$129.00
SBS-CPM/BIOS-cpm for SBC-100 w/BIOS	\$150.00
SBS-TurboDOS-Multiuser for master & slaves	\$445.00

BOARD SETS

Best Bare Board Set Available

QTC-SBC-224 CPU	
QTC-EXP-III 256K Memory bd.	
QTC-PDC 518 Floppy disk controller	
Bare Board Set	\$150.00

1) includes manuals & assembly instructions.
2) Parts available
3) Monitor & BIOS available. Add \$30.00.

QT CLOCK/CALENDAR

S-100 or Apple - Time in hrs, min, sec - AM/PM or Military
Format - Date in Mo., Day, Yr. Day of Week & Leap Year
recognition - 4 time interrupts (1024 Hz) 1 Hz, 1 min, 1 yr
On board battery will last 18 mos, auto power on

QTC-CCS-BB-100	\$45.00
QTC-CCS-BB-100	\$100.00
QTC-CCS-A (+T) for S-100	\$129.00
QTC-CCS-B (+T) for Apple	\$32.00
QTC-CCA-A for Apple	\$100.00

COMPUPRO

S-100 - all assembled and tested

System 816A	4000.00
20 Slot MB	210.00
CPU 9085/88	399.00
Ram 17-64K	410.00
Ram 21-128K	900.00
Olisk II	610.00
System Support I	310.00
Interface 4	310.00
Active Teammates	50.00
Enclosure 2 (disk)	675.00

Call for others

CPU/MEM/IO

QTC-SBC-248 8 per 1 par	\$60.00
QTC-SBC-216 4 + T	\$79.00
QTC-SBC-80 81 term.	\$29.00
Turbo PDC-1 A-1	\$384.00
Turbo SBC-248 A-T	\$695.00
QTC-EXP-III Bare SBC (dynamic)	\$460.00
QTC-EXP-III Bare A-T (RAM/256K or 1 MEG)	\$460.00
S-RAM 64K 88 (static)	\$60.00
S-RAM 64K 88 (+T)	\$74.00
QTC-ADA-ADA Converter A-T	\$371.00
QTC-Dual CPU 486 IEEE 486 interface bo. A-T	\$471.00



Retail Sales
123 East 200 South
Salt Lake City, Utah 84111



**The Great Salt Lake
Computer Company, Inc.**
1-801-363-3314

Mail Orders
P.O. Box 3150
Salt Lake City, Utah 84110

with LOW, LOW Prices

CALIFORNIA RESIDENTS SAVE 6% SALES TAX

8 YEARS (1976) EXPERIENCE IN COMPUTER MAIL ORDER BUSINESS

PRINTERS

DIABLO	
620 (25CPS/SERIAL)	940.00
630 (40CPS/MULTI-F)	1,925.00
C, ITOH	
Pro-writer I (8510A) Par 120 CPS	365.00
Pro-writer I (8510A) Serial 120 CPS	529.00
Pro-writer II Parallel-15"	669.00
8600 (180CPS) Par or Serial- 18 PIN 90 CPS LTR	1,099.00
JUKI	
6100-18CPS/Diablo Compatible Par	565.00
NEC	
NEC7715 (w/Diablo Emulation)	2,075.00
NEC8023A (100CPS-Par-Graphics)	419.00
MANNESMAN-TALLY	
160L (160CPS-40CPS LTR 10")	635.00
180L (160CPS-40CPS LTR 15")	869.00
OKI-DATA	
Microline 82A (SER & PAR-120CPS 10")	399.00
Microline 83A (SER & PAR-120CPS 15")	629.00
Microline 92 (PAR-160CPS-LTR-10")	519.00
Microline 93 (PAR-160CPS-LTR-15")	899.00
Microline 84P (PAR-200CPS-LTR-15")	969.00
Microline 84S (SER-200CPS-LTR-15")	1,059.00
STAR MICRONICS	
Gemini 10 (new version) (PAR-100CPS-10")	299.00
Gemini 15 (15" carriage)	439.00
SILVER REED	
EXP 550P-17CPS Daisy Wheel-PAR	670.00
EXP 550S-17CPS Daisy Wheel-Serial	690.00
TOSHIBA	
P-1350 (192CPS-120CPS/LTR PAR or Serial)	1,500.00
P-350 (100 CPS-PAR-15")	399.00

APPLE/FRANKLIN ACCESSORIES

ASTAR	
RF Modulator	19.00
ORANGE MICRO	
Grappler & Graphics Interface	121.00
Grappler & 16K Buffer Exp.	179.00
TG PRODUCTS	
Joy Stick	39.00
Paddles	29.00
QUADRAM	
E-RAM 80 (80COL64K)	135.00
PRACTICAL PERIPHERALS	
Microbuffer II 16K PAR or Serial	230.00
Microbuffer II 32K PAR or Serial	259.00
Snapshot	99.00
EVERTEK	
EV16K (16K Add-on Memory)	49.00
MICROTEK	
Dumpling 64K-D	235.00
Dumpling GX-P	75.00
PAR BD	61.00
Memory 128K	299.00
VISTA	
A800 Floppy Controller for 8" Drives	300.00
A-800-1 Cable	27.00
QT/COMPUTE	
CCA-A Clock/Calendar	100.00

SYSTEMS

Apple II E Starter	1,625.00
Eagle PC (16BIT) (1-320 K FD 64 RAM)	1,795.00
Franklin 1000	919.00
Franklin 1200 Starter ..	1,625.00
Kay Pro II	1,495.00
Sanyo MB-100	1,589.00
Televideo TS-803	1,995.00
Toshiba T-100	1,895.00

TRY US FOR OTHERS

OUR SALTIER DEALS

IBM Add-On Drive

* Direct Drive *	
* Quiet (Teac Equiv.) *	
* 320 K/48 TPI *	
* 5ms Track to Track *	
REMEM RFD 480	239.00

S-100 BOARD SET

Z80CPU (Big Z)/64K Mem/Floppy Controller (Double D)	150.00
---	--------

DISK SUB ASSEMBLY

OUR BEST BUYS 8" SUB ASSEMBLY

DDS + O 2EA SS/DD Siemens FD100-8 Drives w/Cabinet	595.00
DDS + 2 2EA DS/DD Mitsubishi M2894-63 w/cabinet	1,075.00
DDS + 4 2EA DS/DD 8" Thinline Drives w/Cabinet	1,150.00
<i>Specify—Vertical or Horizontal Cabinet</i>	

5 1/4" SUB ASSEMBLY

DDS + 5 1EA SS/DD Shugart SA400 Drive	200.00
DDS + 6 2EA SS/DD Shugart SA400 Drive	369.00

PRINTER ACCESSORIES

DIABLO	
Diablo 620-Unf-Direct Tractor	110.00
Diablo 620-Sheet Feeder	720.00
Diablo 630-Bi-Direct Tractor	275.00
Diablo 630-Tractor Sound Cover	29.00
Diablo 630-SGL Sheet Feeder	775.00
JUKI-8100	
Serial Interface	55.00
Bi-Dir Tractor	125.00
Uni-Dir Tractor	90.00
MANNESMAN-TALLY	
Factory Quick Tear	230.00
Auto Front Feed	1,150.00
NEC	
Thimbies	15.00
Vertical Tractor	219.00
Horizontal	152.00
Bi-Dir. Tractor	330.00
Cut Sheet Feeder	1,100.00
OKI-DATA	
84 Cut Sheet Feeder	515.00
8292 Tractor	55.00
Serial Intf. w/2K Buffer (For 82A)	125.00
Serial Intf. w/2K Buffer (For 92 & 93)	110.00
Okigraph II 82A or 83A Graphics ROM	35.00
Okigraph II 82A or 83A Disk for Apple	55.00
STAR-MICRONICS	
Serial Intf. Bd	70.00
Serial Intf. Bd w/2K Buffer	120.00
Commodore 64 Intf. Bd	72.00
TOSHIBA	
P-1350 Cut Sheet Feeder	1,125.00
P-1350 Bi-Dir. Tractor	250.00

IBM ACCESSORIES

MAYNARD	
Floppy Controller	155.00
Floppy Controller (Serial)	225.00
Floppy Controller (PAR)	205.00
QUADRAM	
Quadboard 64K	289.00/459.00
Quadboard II 64K/256K	289.00/459.00
Quad Link (Allows IBM PC to use Apple II Software)	589.00
AST	
Combo Plus (SPC 64K)	269.00
Mega Plus (SC. 64K)	269.00
I/O Plus (SC)	114.00
KEYTRONICS	
Enhance your PC-with a superior keyboard	CALL
64K UPGRADE KIT	
\$48.00	
MICRO-TEK	
IBM 64K w/Parity	239.00
IBM 128K w/Parity	369.00
IBM 256K	639.00

TERMINALS

TELEVIDEO

TV910	560.00
TV925	715.00
TV950	925.00
TV970	1,095.00
RG1000/TV60 Graphics Upgrade for 925/950 ...	1,100.00

WYSE

WYSE-100	725.00
WYSE-300 (Color)	1,125.00

MULLEN COMPUTER

TB-4A Extender BD w/Logic Probe ...	80.00
ICB-10 8 Channel Low Voltage Controller BD	180.00
ZB-1 ZIF Extender Test BD	130.00



Retail Sales

123 East 200 South
Salt Lake City, Utah 84111



The Great Salt Lake
Computer Company, Inc.

1-801-363-3314



Mail Orders

P.O. Box 3150
Salt Lake City, Utah 84110

S-100 MEMORY BOARDS

64K STATIC RAM - Jade

Uses new 2K x 8 static RAMs, fully supports IEEE696 24 bit extended addressing, 200ns RAMs, lower 32K or entire board phantomable. 2716 EPROMs may be subbed for RAMs, any 2K segment of upper 8K may be disabled, low power typically less than 500ma.

MEM-99152B Bare board	\$49.95
MEM-99152K Kit less RAM	\$99.95
MEM-32152K 32 kit	\$199.95
MEM-56152K 56K kit	\$289.95
MEM-64152K 64K kit	\$299.95
Assembled & Tested	add \$50.00

EXPANDORAM III

SD Systems new ExpandoRAM III is a high density S-100 memory board utilizing the new 64K x 1 dynamic RAM chips. It allows memory sizes of 64K, 128K or 256K all on a single S-100 board.

MEM-65064A 64K	\$495.00
MEM-65128A 128K	\$595.00
MEM-65192A 192K	\$675.00
MEM-65256A 256K	\$755.00

LETTER QUALITY PRINTERS

Lowest Price Daisywheel Printer - JUKI

Full featured daisywheel printer with graphics mode and built-in word processing functions. 18 CPS print speed, 13 inch platen, 10, 12, or 15 pitch plus proportioned spacing. Uses standard IBM ribbons. This is an extremely reliable letter quality printer, at an unheard of low price!

PRD-61001 Parallel	\$629.95
PRD-61002 RS232 serial board	\$59.95
PRA-61000 Tractor option	\$139.95

380Z by D.T.C.

Based on the same quality mechanism as the Comrex printer, the 380Z contains electronic enhancements that allow it to print at speeds up to 32 CPS. Other features include a 48K buffer, proportional spacing, and Diablo 1640/1650/630 compatible protocol. Comes with printwheel, ribbon and users manual. Serial, parallel, and IEEE 488 interfaces standard.

PRD-11300 380Z printer	\$1295.00
PRA-11000 Tractor option	\$169.95
PRA-1200 Cut sheet feeder	\$699.95
Cable Please specify	\$49.95

Printers From Jade

SEIKOSHA 10" Graphics, 30 CPS	\$229.95
OKIDATA 82 10" 120 CPS	CALL
OKIDATA 92 10" 160 CPS with Graphics	CALL
OKIDATA 93 15" 160 CPS with Graphics	CALL
OKIDATA 83 15" 120 CPS with Tractor	CALL
OKIDATA 84 15" 200 CPS with Graphics	CALL
OKIDATA 2350 15" 350 CPS	CALL
OKIDATA 2410 15" 350 CPS, Two color	CALL
DAISYWRITER 2000 48K Daisywheel	\$1395.00
GEMINI 10 100 CPS 10" with Graphics	\$349.95
GEMINI 15 100 CPS 15" with Graphics	\$499.95
COMREX CR1	\$849.95
SILVER REED	\$699.95
STARWRITER F-10	\$1249.95

PRINTER PALS — FMJ

Desk top printer stand and paper rack. Fits all printers.

PRA-99080 10" Printer pal	\$29.95
PRA-99100 15" Printer pal	\$39.95
PRA-99700 for Letter Quality	\$49.95

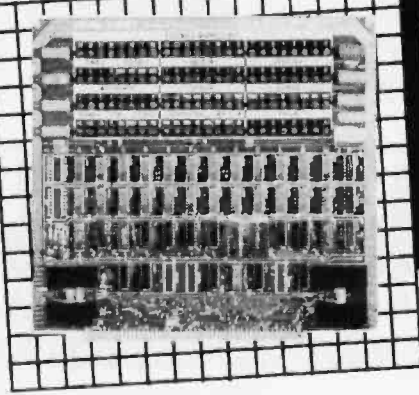

S-100 I/O BOARDS

The BUS PROBE — Jade

Inexpensive S-100 Diagnostic Analyzer

TSX-200B Bare board	\$59.95
TSX-200K Kit	\$129.95
TSX-200A A & T	\$159.95

I/O-4 — SSM Microcomputer

2 serial I/O ports plus 2 parallel I/O ports

IOI-1010A A & T	\$249.95
-----------------	----------

I/O-5 — SSM Microcomputer

Two serial & 3 parallel ports, 110-19.2K Baud

IOI-1015A A & T	\$289.95
-----------------	----------

INTERFACER 4 — CompuPro

3 serial, 1 parallel, 1 Centronics parallel

IOI-1840A A & T	\$389.95
JOI-1830C CSC	\$495.00

S-100 EPROM BOARDS

PB-1 — SSM Microcomputer

2708, 2716 EPROM board with on-board programmer

MEM-99510K Kit with manual	\$154.95
MEM-99510A A & T with manual	\$219.95

PROM-100 — SD Systems

2708, 2716, 2732 EPROM programmer with software

MEM-99520K Kit with software	\$189.95
MEM-99520A A & T with software	\$249.95

VIDEO MONITORS

VIDEO MONITOR — Jade

1000 lines ultra-high resolution, 20 MHz ultra-high band width, 9" or 12". Amber or Green phosphor, the finest monitors we sell.

VDM-740920 9" Green	\$99.95
VDM-740910 9" Amber	\$129.95
VDM-751220 12" Green	\$129.95
VDM-751210 12" Amber	\$139.95

12" GREEN SCREEN — Zenith

15MHz, 40 or 80 column

VDM-201201 12" Green	\$114.95
----------------------	----------

DUAL DISK SUB-SYSTEMS

DISK Sub-Systems — Jade

Handsome metal cabinet with proportionally balanced air flow system, rugged dual drive power supply power cable kit, power switch, line cord, fuse holder, cooling fan, nevermar rubber feet, all necessary hardware to mount 2-8" disk drives, power supply, and fan, does not include signal cable.

Dual 8" Sub-Assembly Cabinet

END-000420 Bare cabinet	\$49.95
END-000421 Cabinet kit	\$199.95
END-000431 A & T	\$249.95

8" Sub-Systems — Single Sided, Double Density

END-000423 Kit w/2 Siemens FD100-8Ds	\$650.00
END-000424 A & T w/2 Siemens FD100-8Ds	\$695.00
END-000433 Kit w/2 Shugart SA-801Rs	\$999.95
END-000434 A & T w/2 Shugart SA-801Rs	\$1195.00

8" Sub-Systems — Double Sided, Double Density

END-000426 Kit w/2 Qume DT-8s	\$1224.95
END-000427 A & T w/2 Qume D-8s	\$1424.95
END-000436 Kit w/2 Shugart SA-851Rs	\$1274.95
END-000434 A & T w/2 Shugart SA-801Rs	\$1195.00

S-100 MOTHERBOARDS

ISO-BUS - Jade

Silent, simple and on sale — a better motherboard

6 Slot (5 1/4" x 8 1/2")	
MBS-061B Bare board	\$22.95
MBS-061K Kit	\$39.95
MBS-061A A & T	\$69.95

12 Slot (9 1/4" x 8 1/2")	
MBS-121B Bare board	\$34.95
MBS-121K Kit	\$69.95
MBS-121A A & T	\$109.95

18 Slot (14 1/2" x 8 1/2")	
MBS-181B Bare board	\$54.95
MBS-181K Kit	\$149.95
MBS-181A A & T	\$199.95

S-100 CPU BOARDS

The BIG Z — Jade

2 or 4 MHz switachable Z-80 CPU board with serial I/O accommodates 2708, 2716, or 2732 EPROM, baud rates from 75 to 9600.

CPU-30201B Bare board w/manual	\$35.00
CPU-30201K Kit with Manual	\$149.95
CPU-30201A A & T with Manual	\$199.95

SBC-200 - SD Systems

4 MHz Z-80A CPU with serial & parallel I/O, 1K RAM, 8K ROM space, monitor PROM included.

CPU-30200A A & T	\$329.95
------------------	----------

CPU-Z CompuPro

2 or 4 MHz Z80A CPU, 24 bit addressing

CPU-30500A 2/4 MHz A & T	\$279.95
CPU-30500C 3/6 MHz CSC	\$374.95

8085/8088 — CompuPro

Both 8 & 16 bit CPUs, standard 8 bit S-100 bus, up to 8 MHz, accesses 16 Megabytes of memory

CPU-20510A 6 MHz A T	\$429.95
CPU-20510C 6/8 MHz CSC	\$529.95

PLACE ORDERS TOLL FREE

Continental U.S.
800-421-5500

Inside California
800-262-1710

For Technical Inquires
or Customer Service call:
213-973-7707

We accept cash, checks, credit cards, or Purchase Orders from qualified firms and institutions.
Minimum prepaid order \$15.00 California residents add 6 1/2% tax. Export customers outside the US or Canada please add 10% to all prices. Prices and availability subject to change without notice. Shipping and handling charges via UPS Ground 50¢/lb. UPS Air \$1.00/lb. minimum charge \$3.00

Circle 218 on Inquiry card.

5 1/4" DISK DRIVES

Tandon TM 100-1 Single sided, double density 48 TPI
MSM-551001 \$219.95 ea 2 for \$199.95 ea
Shugart SA 400L Single sided, double density 40 track
MSM-104000 \$234.95 ea 2 for \$224.95 ea
Tandon TM 100-2 Double sided, double density 48 TPI
MSM-551002 \$294.95 ea 2 for \$269.95 ea
MPI B52 Double sided, double density, 48 TPI can be
substituted for CDC
MSM-155200 \$299.95 ea 2 for \$279.95 ea
MPI B51 Single sided, double density 48 TPI
MSM-155100 \$239.95 ea 2 for \$199.95 ea

5 1/4" Cabinets With Power Supply

END-000216 Single cab w/power supply \$69.95
END-000226 Dual cab w/power supply \$94.95

8" SLIMLINE SUB-SYSTEMS

Dual Slimline Sub-Systems — Jade

Handsome vertical cabinet with scratch resistant baked enamel finish, proportionally balanced air flow system, quiet cooling fan, rugged dual drive power supply, power cables, power switch, line cord, fuse holder, cooling fan, all necessary hardware to mount 2-8" slimline disk drives. Does not include signal cable.

Dual 8" Slimline Cabinet
END-000820 Bare cabinet \$59.95
END-000822 A & T w/o drives \$179.95

Dual 8" Slimline Sub-Systems
END-000823 Kit w/2 SS DD Drives \$919.95
END-000824 A & T w/2 SS DD Drives \$949.95
END-000833 Kit w/2 DS DD Drives \$1149.95
END-000834 A & T w/2 DS DD Drives \$1179.95

8" DISK DRIVES

Siemens FDD 100-8 Single sided, double density
MSF-201120 \$274.95 ea 2 for \$249.95 ea
Shugart SA 801R Single sided, double density
MSF-10801R \$394.95 ea 2 for \$389.95 ea
Shugart SA 851R Double sided, double density
MSF-10851R \$554.95 ea 2 for \$529.95 ea
Qume DT-8 Double sided, double density
MSF-750080 \$554.95 ea 2 for \$529.95 ea
Tandon TM 84841 Single sided, double density thin-line
MSF-558481 \$379.95 ea 2 for \$369.95 ea
Tandon TM 848-2 Double sided, double density thin line
MSF-558482 \$494.95 ea 2 for \$484.95 ea
NEC FD1165 Double sided, double density thin line
MSF-851165 \$484.95 ea 2 for \$449.95 ea

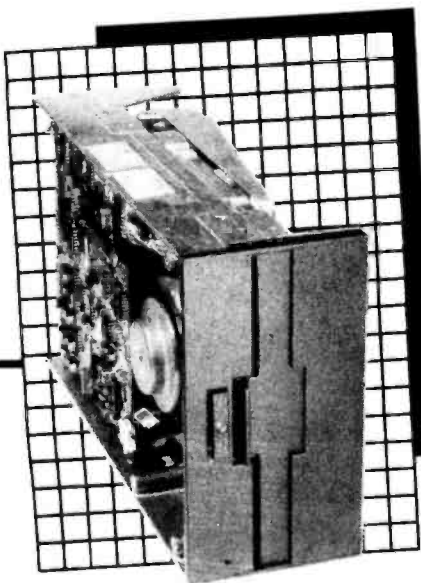

MODEMS

Smart Buy in MODEMS — Signalman

1200 and/or 300 baud, direct connect, automatic answer or originate selection, auto-answer/auto-dial on deluxe models. 9v battery allows total portability, full one year warranty.

IOM-5600A 300 baud direct connect \$89.95
IOM-5610A 300 baud Deluxe \$149.95
IOM-5620A 1200/300 baud Deluxe \$369.95
IOM-5650A 300 baud for Osborne \$119.95
IOM-5630A 300 baud card for IBM \$199.95

SMARTMODEM — Hayes

Sophisticated direct-connect auto-answer/auto-dial modem, touch-tone or pulse dialing, RS-232C interface programmable

IOM-5500A Smartmodem 1200 \$574.95
IOM-5400A Smartmodem 300 \$224.95
IOM-1500A Hayes Chronograph \$218.95
IOM-1100A Micromodem 100 \$368.95
IOM-2010A Micromodem II w/Term prgm \$329.95
IOM-2012A Terminal program for MMII \$89.95

1200 BAUD SMART CAT — Novation

103/212 Smart Cat & 103 Smart Cat, 1200 & 300 baud, built-in dialer, auto re-dial if busy, auto answer/disconnect, direct connect, LCD readout displays mode analog/digital loopback self tests, usable with multi-line phones.

IOM-5241A 300 baud 103 Smart Cat \$229.95
IOM-5251A 1200 baud 212/103 Smart Cat \$549.95

J-CAT™ MODEM — Novation

1/5 the size of ordinary modems, Bell 103, manual or auto-answer, automatic answer/originate, direct connect, built-in self-test, two LEDs and audio beeps provide status information.

IOM-5261A Novation \$149.95

S-100 DISK CONTROLLERS

VERSAFLOPPY II - SD Systems

Double density disk controller for any combination of 5 1/4" and 8" single or double sided, analog phase-locked loop data separator, vectored interrupts, CP/M 2.2 & Oasls compatible control/diagnostic software PROM included.

IOD-1160A A & T With Prom \$359.95
SFC-55009047F CP/M 3.0 With VF-II \$139.95

2422 DISK CONTROLLER — C.C.S.

5 1/4" or 8" double density disk controller with on-board boot loader ROM, free CP/M 2.2 & manual set

IOD-1300A A & T with CP/M 2.2 \$399.95

DOUBLE D — Jade

High reliability double density disk controller with on-board Z-80A, auxiliary printer port, IEEE S-100 can function in multi-user interrupt driven bus.

IOD-1200B Bare board & hdwr man \$59.95
IOD-1200K Kit w/hdwr & sltwr man \$299.95
IOD-1200A A & T w/hdwr & sltwr man \$325.00
SFC-59002001F CP/M 2.2 with Double D \$99.95

DISK TUBS

DISKETTE STORAGE BOXES

Clear Plexiglass storage boxes for up to 75 Diskettes
MMA-505 Holds 75 5 1/4" Diskettes \$19.95
MMA-508 Holds 50 8" Diskettes \$24.95

EPROM ERASERS

ULTRA-VIOLET EPROM ERASERS

Inexpensive erasers for industry or home.

XME-3100A Spectronics w/o timer \$69.50
XME-3101A Spectronics with timer \$94.95
XME-3200A Logical Devices \$49.95

APPLE II ACCESSORIES

SUPER DISKETTE SPECIAL!

We bought out a major manufacturer's overstock, and we are passing the savings on to you! Single sided, double density, package of 10 in plastic library case.

MMD-5121003 Apple Diskettes \$18.95

DISK DRIVE - Fourth Dimension

Totally Apple compatible, 143,360 bytes per drive on DOS 3.3 full one year factory warranty, half-track capability reads all Apple software, plugs right into Apple controller as second drive, DOS 3.3, 3.2.1 Pascal, & CP/M compatible.

MSM-431010 Forth Dimension drive \$249.95
MSM-431030 Controller only \$60.00
MSM-431040 Controller with software \$99.95

HALF-HEIGHT DRIVE - Laser Micro.

Totally Apple Compatible. Works with all Apple software and controllers. Faster and quieter than most other drives, yet only half the size!

MSM-571010 Laser half-height \$299.95

CP/M 3.0 CARD for Apple — A.L.S.

The most powerful card available for your Apple! 6MHz Z-80B, additional 64K of RAM, CP/M 3.0 plus 100% CP/M 2.2 compatibility, C basic, CP/M Graphics, 300% faster than any other CP/M for Apple. One year warranty.

CPX-62810A A.L.S. CP/M Card \$349.95

Z-CARD for Apple II — A.L.S.

Two computers in one, Z-80 & 6502, more than doubles the power and potential of your Apple, includes Z-80 CPU card CP/M 2.2 and complete manual set. Pascal compatible utilities are menu-driven, one year warranty.

CPX-62800A A & T with CP/M 2.2 \$159.95

80 COLUMN APPLE CARD

80 column x 24 line video card for Apple II, addressable 25th status line, normal/inverse or high/low video, 128 ASCII characters, upper and lower case, 7 x 9 dot matrix with true descenders, CP/M, Pascal & Fortran compatible, 50/60 Hz, 40/80 column selection from keyboard. Best 80 column card!

IOV-2450A Viewmax 80 \$149.95
IOV-2455A Preboot disk for above \$29.95

16K RAM Card — for Apple II

Expand your Apple II 64K, use as language card, full 1 year warranty. Why spend \$175.00?

MEX-16700A Save over \$115.00 \$49.95

GRAPPLER PLUS - Orange Micro

The ultimate parallel printer Graphics interface card with many new features, now at a new low price!

IOP-2300A Grappier Plus \$139.95

JADIE

Computer Products

4901 West Rosecrans Ave. Hawthorne, California 90250

Computer Components Unlimited

Expert Service

No Surcharge for Credit Cards



Toll-Free Number

NOW HAS A COMPLETE

APPLE SOFTWARE

Ashton tate

D Base II \$409

Art Sci

Magic Calc \$ 99
 Magic Window II 109
 Magic Words 89

Continental Software

Home Accountant \$ 59

Info Com

Zork I \$26⁹⁵
 Zork II 26⁹⁵
 Zork III 26⁹⁵

Micro Pro

Calclstar \$ 99
 Datastar 199
 Mailmerge 169
 Reportstar 239
 Spellstar 169
 Supersort 169
 Wordstar 269

Micro Soft

Basic Compiler \$269
 Cobol-80 499
 Fortran-80 139
 Multiplan 189

Peach Tree

Call for lowest prices

Stoneware

DB Master \$169

IBM PC SOFTWARE

Ashton Tate

D Base II \$409
 D Base II 8" 419

Continental

Home Accountant Plus \$ 99
 Property Management 299

Info Com

Zork I \$ 27
 Zork II 27
 Zork III 27

Micro Lab

Tax Manager \$179

Micro Pro

Wordstar \$299
 Mailmerge 159
 Spellstar 159

Peach Tree

General Ledger \$345
 Accounts Receivable 345
 Accounts Payable 345

Sorcirm

Super Calc \$199

Micro Soft

Multiplan \$189

SPECIALS OF THE MONTH

Micro-Sci A-2

- Fully Apple Compatible
- Faster Than Apple
- Fully Documented

\$229.00

Rana Elite I

- Fully Apple Compatible
- Faster Than Apple
- More Storage
- Write Protect Switch

\$269.00

BMC 9191 Color Monitor

- Composite Video
- Audek Color Compatible
- Good Resolution

\$249.00

Sanyo Monitor

- 9" Green
- 24 x 60

ONLY \$89.00

Hayes 300 Baud Modem

- Top of the Line
- Serial Interface

\$199.00

Hayes 1200 Baud \$499.00

C. ITOH Starwriter

F-10 40 PU

- Letter Quality
- 1 Yr. Warranty

\$1149.00

Axiom by Seiko Printer

- 30 CPS
- Parallel Interface
- Dot by Dot Graphic
- 2 Yr. Warranty

\$199.00

Ashton Tate

- D Base II
- \$409.00**

Lowest Advertised Price Ever

5 1/4" Diskettes 100 for ONLY \$150

- Reinforced Hub
- Sgl. side Dbl. Density
- 5 Yr. Warranty

Viewmax 80

- 80 Col. For Apple
- Videx Compatible
- W/Soft Switch
- W/Inverse Charter Switch
- 2 Yr. Warranty

\$149.00

Siemens 8" Disk Drive

- FDD100 - 8D
- 801R Shugart Compatible
- Factory Sealed
- 90 Day Warranty

\$179.00

RF Modulator

- Apple II and Apple IIE Compatible

\$ 19.00

CALL 800-847-1718

For Weekly Specials

- Dealer Inquiries Invited
- Quantity Discounts Available

We Offer More Than Just Low Prices!!!

www.apple.com/apple/education/

All Products Have 90 Day
to 5 Yr. Warranty

Virtually No Backorders

APO and foreign orders
- no additional charge

C.O.D.S



LINE OF SOFTWARE

PERSONAL & PORTABLE SYSTEMS

Franklin Ace 1000 w/color	Call
Franklin Ace 1200 w/Drive	Call
Apple II E Starter System	\$1725
Kaypro II	1649
Syscom II	625
Commodore 64 w/Drive	795
Sanyo MBC 1000	1589
Compac. Columbia, Corona	Call

APPLE, FRANKLIN Accessories

Advanced Logic Systems

cpm 3.0 Card	\$ 339
Z Card cpmCard	139

Astar

RF Modulator	19
--------------	----

Gibson

Light pen for Apple II & IIE	249
------------------------------	-----

Kensington

System Saver / Fan & Surge	69
----------------------------	----

Micro Max

Viewmax 80 Col. Card	149
----------------------	-----

Micro Soft Products

Softcard w/ cpm	239
16K Card	65
Premium Pack	469

Micro Tek

128K Memory Board	299
Q Puk Memory	329

Orange Micro

Grappler + Graphics Interface	121
Buffer Board w/ 16K Buffer Exp.	139
Grappler + 16K Buffer Exp.	179

TG Products

Joystick	39
Paddles	29
Selecta PORT	39

MODEMS

Hayes Micro Computer

300 Baud Smart Modem	\$ 199
1200 Baud Smart Modem	499
Micro Modem II	259
Micro Modem II w/ Terminal Package	279

Novation

J-Cat 300 Baud	119
Apple Cat II	269

US Robotic

212A Auto Dial	469
----------------	-----

IBM PC Accessories

Tandon

TM100-1160K	\$ 179
TM100-2320K	239

Profit Systems Inc.

Parallel Port, Serial Port, Clock Calendar 64K & All Needed Software	329
Same as above except 512K	699

UPGrade

64k w/ parity	\$9
---------------	-----

5 1/4" & 8" DISK DRIVES

Siemens

FDD100-8D 8" Sgl/Dbl Den	\$ 179
--------------------------	--------

Mitsubishi

2894-63 Dbl/Dbl Den	399
---------------------	-----

Shugart

SA801R Sgl/Dbl Den	359
SA851R Dbl/Dbl Den	479

Tandon

TM 100-1 160K	179
TM 100-2 320K	239
TM 101-4 Quad Density	339
TM 848-1 Sgl/Dbl Den	359
TM 848-2 Dbl/Dbl Den	449

Teac

FD 55 A 1/2 HT 160K	199
FD 55 B 1/2 HT 320K	279

PRINTERS PRICING WILL NOT BE BEAT

C. Itoh

Gorilla (NEW)	Call
Prowriter I (Parallel)	\$ 365
Prowriter I (Serial)	529
Prowriter II (Parallel)	675
Starwriter F-10	1149
F-10 Tractor	209
8600 (180cps)	1099

Star Micronics

Gemini 10 (New Version)	299
Gemini 15 (15" carriage)	439

Okidata

Microline 92 (160cps)	499
Microline 93 (15" carriage)	899
Microline 82A (Par. & Serial)	399
Microline 83A (15" carriage)	629
Microline 84P (200cps)	969
Microline 84S (200cps)	1059

Axiom

Seikosha GP100A	199
Seikosha GP250X	239

Nec

Nec 8023A	Price Reduction	429
-----------	-----------------	-----

Epson

RX, MX, FX	Call
------------	------

Toshiba

P1350	Top of the Line	1599
-------	-----------------	------

DISK DRIVES FOR APPLE & FRANKLIN

Rana Systems

Elite I	\$ 269
Elite II	429
Elite III	539
•Add \$70 for Controller	

Micro Sci

A-2	229
A-40	279
A-70	359
•Add \$70 for Controller	

Quentin Research

Apple Mate	249
5 Megabyte Hardisk	1695

VIDEO DISPLAY MONITORS

USI

PI 1 (9" Amber HiRes)	\$ 139
PI 2 (9" Green HiRes)	129
PI 3 (12" Amber HiRes)	149
PI 4 (12" Green HiRes)	139

Sanyo

DM 5109 (9" Green)	89
DM 2112 (12" Green)	84

BMC

12 AU (12" Green)	79
9191 Color Composite	249

Zenith

ZVM121 (12" Green)	94
--------------------	----

Amdek

Color 1+ w/sound	299
Color II RGB	569

Princeton Graphics

PGS Hx12 w/IBM Cable	499
----------------------	-----

LOW PRICED Hi Quality DISKETTES

5 1/4" Disks

Sgl Side/Dbl Density	\$17 a box
Dbl Side/Dbl Density	27 a box

8" Disks

Sgl Side/Dbl Density	28 a box
Dbl Side/Dbl Density	34 a box

All Disks come w/ Reinforced Hub, 5 yr warranty and not bulk packed.

Advanced Access

Smoked Plexiglass Diskette Tub Holds 80 8" Version	19
	26

PRINTER CABLES

IBM to Printer	\$ 32
Osborne to Printer	32
Kaypro to Printer	32
Apple Card & Cable	49

DISK DRIVE CABINETS

5 1/4" Cabinets

Sgl Cabinet w/pwr. supply	\$ 59
Dual Cabinets w/pwr supply	89

8" Cabinets

Sgl Cabinets w/fan & pwr. supply	209
Dual Cabinets w/fan & pwr. supply	259

If you don't see what you are looking for, give us a call, we have much more available

800-847-1718
All Orders

NEW RETAIL STORE:
11976 Aviation Blvd.
Inglewood, CA 90304

MAIL ORDER:
P.O. Box 1936

www.hawthorne.com

Technical & Customer Service
(213) 219-0808

All merchandise new. We accept MC, Visa, Wire Transfer, COD Call, Certified Check, P.O.'s from qualified firms, APO accepted. Shipping: Minimum \$3.50 first 5 pounds. Tax: California Res. Only add 6 1/2% sales tax.

Prices Subject to Change

Mon.-Fri. 7 a.m. to 6 p.m.
Sat. & Sun. 11 a.m. to 4 p.m.

Computer Components Unlimited

Do Kay Computer Products, Inc.

VISIT OUR RETAIL STORE

2100 DE LA CRUZ BLVD.

SANTA CLARA, CA 95050

16K APPLE II RAM CARD

BARE BOARD 14.00

ASSEMBLED 42.50

*Apple is a trademark of Apple Computer, Inc.

INTERFACE

8T26	1.65
8T28	1.95
8T95	.95
8T96	.95
8T97	.95
8T98	.95
DM8131	2.90
DP8304	2.25
DS8835	1.89
DS8836	.99

EPROMS

1702	1ns	2.95
2708	450ns	2.98
2758	450ns	5.89
2716	450ns	3.90
2716-1	350ns	5.90
TMS2516	450ns	5.49
TMS2716	450ns	7.89
2532	450ns	5.35
2732	450ns	4.90
2764	450ns	CALL
MC68764	450ns	34.95

DYNAMIC RAMS

TMS 4027	250ns	.79
UPD 411	300ns	2.89
MM 5280	300ns	2.89
MK4108	200ns	1.74
MM 5298	250ns	1.74

STATIC RAMS

2101	450ns	1.80
5101	450ns	3.89
2102-1	450ns	.78
2102L-2	250nsLP	1.44
2111	450ns	2.48
2112	450ns	2.58
2114	450ns	1.74
2114L-4	450nsLP	1.84
2114L-3	300nsLP	1.84
2114L-2	200nsLP	1.94
2147	55ns	4.89
TMS4044-4	450ns	3.15
TMS4044-3	300ns	3.45
TMS4044-2	200ns	3.89
MK4118	250ns	9.69
TMM2015	200ns	4.15
TMM2016	150ns	4.89
HM6116-4	200ns	5.90
HM6116-3	150ns	6.90
HM6116-2	120ns	8.95
26132	300ns	32.95

LP = LOW POWER

RESISTORS

1/4 WATT 5% CARBON FILM
ALL STANDARD VALUES
FROM 1 OHM TO 10 MGE OHM
50 PCS. SAME VALUE .0200
100 PCS. SAME VALUE .0150
1000 PCS. SAME VALUE .0125

6500 1 MHz

6502	5.25
6504	6.85
6505	7.60
6507	9.85
6520	3.95
6522	4.95
6532	5.95
6545	16.95
6551	10.95

2 MHz

6502A	8.95
6522A	9.95
6532A	11.90
6545A	27.90
6551A	11.90

3 MHz

6502B	11.90
-------	-------

APPLE ROM SET

69.95

AUTOSTART ROM

34.95

UARTS

AY3-1014	5.85
AY5-1013	3.90
AY5-1015	6.90
TR1602	3.90
IM6402	7.85
IM6403	8.85
INS8250	10.49

LEDS

Jumbo Red	10/1.00
Jumbo Green	6/1.00
Jumbo Yellow	6/1.00

DIP SWITCHES

4 Position	.85
5 Position	.90
6 Position	.90
7 Position	.90
8 Position	.95

EXAR

XR 2206	3.75
XR 2207	3.75
XR 2208	3.90
XR 2211	5.25
XR 2240	3.25

RCA

CA 3010	.95
CA 3013	1.99
CA 3023	2.75
CA 3035	2.49
CA 3039	1.25
CA 3046	1.25
CA 3053	1.45
CA 3059	2.90
CA 3060	2.90
CA 3065	1.75
CA 3080	1.10
CA 3081	1.65
CA 3082	1.65
CA 3083	1.65
CA 3086	.80
CA 3089	2.10
CA 3130	1.25
CA 3140	1.15
CA 3146	1.75
CA 3160	1.15
CA 3401	.59
CA 3600	3.45

-VIEWMAX 80-

A Full Function
80-Column
card for Apple II

\$149⁹⁵

APPLE JOYSTICKS 29.95

APPLE
SUPER COOLING
FANS
49.95

WITH SURG PROTECH
69.95

APPLE PADDLES 9.95

APPLE **UPGRADE** TRS-80
4116 - 200ns
CALL

74LS00	.23	74LS123	.77	74LS253	.57
74LS01	.23	74LS124	2.88	74LS257	.57
74LS02	.23	74LS125	.47	74LS258	.57
74LS03	.23	74LS126	.47	74LS259	2.73
74LS04	.23	74LS132	.57	74LS260	.57
74LS05	.23	74LS136	.37	74LS266	.53
74LS08	.23	74LS137	.97	74LS273	1.47
74LS10	.23	74LS138	.53	74LS275	3.33
74LS11	.25	74LS139	.53	74LS279	.47
74LS12	.25	74LS145	1.18	74LS280	1.96
74LS13	.39	74LS147	2.47	74LS283	.67
74LS14	.39	74LS148	1.33	74LS290	.87
74LS15	.29	74LS151	.53	74LS293	.87
74LS20	.23	74LS153	.53	74LS295	.97
74LS21	.23	74LS154	1.88	74LS298	.87
74LS22	.23	74LS155	.67	74LS324	1.73
74LS26	.29	74LS156	.67	74LS352	1.27
74LS27	.23	74LS157	.63	74LS353	1.27
74LS28	.29	74LS158	.57	74LS363	1.33
74LS30	.23	74LS160	.67	74LS364	1.93
74LS32	.25	74LS161	.63	74LS365	.47
74LS33	.49	74LS162	.67	74LS366	.47
74LS37	.29	74LS163	.63	74LS367	.43
74LS38	.29	74LS164	.67	74LS368	.43
74LS40	.23	74LS165	.93	74LS373	1.37
74LS42	.43	74LS166	1.93	74LS374	1.37
74LS47	.49	74LS168	1.73	74LS377	1.37
74LS48	.74	74LS169	1.73	74LS378	1.17
74LS49	.74	74LS170	1.47	74LS379	1.33
74LS51	.23	74LS173	.67	74LS385	1.88
74LS54	.23	74LS174	.53	74LS386	.43
74LS55	.28	74LS175	.53	74LS390	1.17
74LS63	1.23	74LS181	2.13	74LS393	1.17
74LS73	.37	74LS189	8.93	74LS395	1.17
74LS74	.33	74LS190	.87	74LS399	1.47
74LS75	.37	74LS191	.87	74LS424	2.93
74LS76	.37	74LS192	.77	74LS447	.35
74LS78	.47	74LS193	.77	74LS490	1.93
74LS83	.58	74LS194	.67	74LS668	1.67
74LS85	.67	74LS195	.67	74LS669	1.87
74LS86	.37	74LS196	.77	74LS670	1.47
74LS90	.53	74LS197	.77	74LS674	9.63
74LS91	.87	74LS221	.87	74LS682	3.18
74LS92	.53	74LS240	.93	74LS683	3.18
74LS93	.53	74LS251	.59	74LS684	3.18
74LS95	.73	74LS242	.97	74LS685	3.18
74LS96	.87	74LS243	.97	74LS688	2.38
74LS107	.37	74LS244	1.27	74LS689	3.18
74LS109	.37	74LS245	1.47		
74LS112	.37	74LS247	.73	81LS95	1.47
74LS113	.37	74LS248	.97	81LS96	1.47
74LS114	.37	74LS249	.97	81LS97	1.47
74LS122	.43	74LS251	.57	81LS98	1.47

STORE HOURS:

MON-FRI 8:30 A.M.-5:30 P.M.
SAT 10:00 A.M.-3:00 P.M.

Do Kay Computer Products, Inc.



2100 De La Cruz Blvd.
Santa Clara, CA 95050

(800) 538-8800

Calif. Residents
(800) 848-8008

Local Phone
(408) 988-0697

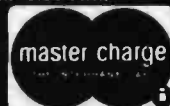

TERMS: For shipping include \$2.00 for UPS Ground. \$3.00 for UPS Blue Label Air. \$10.00 minimum order. Bay Area residents add 6 1/2% Sales Tax. California residents add 6% Sales Tax. We reserve the right to limit quantities and substitute manufacturer. Prices subject to change without notice. Send SASE for complete list.

APPLE II USERS DISK DRIVE!

- Includes metal cabinet
- Color matches Apple
- 35 tracks/single side
- Includes cable
- Use with Apple II controller

225.95

CONTROLLER CARD 79.95

EPROM ERASERS

HOLDS 15 EPROMS
ERASES IN 20 MINUTES

59.95

Z 80 SERIES

2.5 MHz	
Z80-CPU	3.35
Z80-PIO	3.35
Z80-CTC	3.35
Z80-DMA	12.49
Z80-DART	14.98
Z80-SIO/O	16.95
Z80-SIO/1	16.95
Z80-SIO/2	16.95
Z80-SIO/9	16.95
4.0 MHz	
Z80A-CPU	4.90
Z80A-PIO	4.90
Z80A-CTC	4.90

Z80A-DMA	21.95
Z80A-DART	15.95
Z80A-SIO/0	20.95
Z80A-SIO/1	20.95
Z80A-SIO/2	20.95
Z80A-SIO/9	18.95

6.0 MHz	
Z80B-CPU	14.95
Z80B-PIO	12.95
Z80B-CTC	12.95

ZILOG	
Z6132	32.95
Z8671	38.95

WIREWAP CARDS

FR-4 Epoxy Glass Laminate With Gold-Plated Contact Fingers

S-100 BUSS

P100-1	Bare—No Foil Pads	15.90
P100-2	Horizontal BUSS	22.90
P100-3	Vertical BUSS	22.90
P100-4	Single Foil Pads per Hole	23.90

GENERAL PURPOSE

22/44 PIN (.156" SPACING)		
P441-3	Vertical BUSS, 4.5" x 6"	13.90
P442-3	Vertical BUSS, 4.5" x 9"	14.90
36/72 PIN (.1" SPACING)		
P721-3	Vertical BUSS, 4.5" x 6"	13.90
P722-3	Vertical BUSS, 4.5" x 9"	14.90

APPLE

P500-1	Bare—No Foil Pads	15.90
P500-3	Horizontal BUSS	22.90
P500-4	Single Foil Pads per Hole	23.90

5 1/4" DISKETTES

ATHANA OR NASHUA

SSSD 18.95

SSDD 22.95

DSDD 27.95

**BULK
SSDD SOFT
\$1.65 EA**

LINEAR

LM301	.32	LM741	.29
LM308	.75	LM747	.75
LM309K	1.25	LM748	.49
LM311	.64	LM1310	2.45
M317T	1.65	MC1330	1.69
LM317K	1.70	MC1350	1.25
LM318	1.49	MC1358	1.69
LM323K	3.75	LM1414	1.49
LM324	.59	LM1458	.55
LM337K	3.90	LM1488	.65
LM339	.79	LM1489	.65
LM377	2.25	LM1800	2.45
LM380	1.25	LM1889	2.45
LM386	1.00	LM3900	.59
LM555	.38	LM3909	.95
LM556	.65	LM3914	3.70
LM565	.95	LM3915	3.70
LM566	1.45	LM3916	3.70
LM567	.99	75451	.35
LM723	.49	75452	.35
LM733	.95	75453	.35

ORDER TOLL FREE

(800) 538-8800

(800) 848-8008

(CALIFORNIA RESIDENTS)

APPLE*
COMPATIBLE
POWER
SUPPLY

\$84.95

Disc Controllers

1771	15.95
1791	27.95
1793	29.95
1795	49.95
1797	49.95
6843	32.95
8272	39.00
UPD765	34.95
1691	17.95

6800 1 MHz

6800	4.75
6802	7.89
6808	8.45
6809	11.95
6809E	17.95
6810	2.89
6820	3.50
6821	2.95
6828	13.95
6840	7.95
6843	32.95
6844	24.95
6845	13.95
6847	11.95
6850	3.20
6852	3.50
6860	9.89
6862	11.90
6875	6.89
6880	1.80
6883	22.95

2 MHz

68B00	9.95
68B02	21.95
68B09	28.95
68B09E	28.95
6810	7.89
6810	11.95
68B45	33.95
68B50	11.95

3 MHz

68000	57.95
-------	-------

IC Sockets

IC SOCKETS

	ST	W/W
8 PIN	.10	.49
14 PIN	.12	.50
16 PIN	.15	.57
18 PIN	.20	.85
20 PIN	.25	.99
22 PIN	.25	1.30
24 PIN	.25	1.40
28 PIN	.35	1.50
40 PIN	.40	1.80

ST = Soldertail
W/W = Wirewrap

5 1/4" FLOPPY DISKS

FLIP FILE
CAPACITY 75 EA

19.95



9000 SERIES		CLOCK CIRCUITS	
16	.95	MM5314	4.90
34	2.39	MM5369	3.90
68	3.69	MM5375	4.90
01	8.95	MM58167	8.90
01	.69	MM58174	10.95
02	1.39		
502	1.79	MSM5832	6.90

VOLTAGE REGULATORS			
7805T	.75	7908T	.85
7808T	.75	7912T	.85
7812T	.75	7915T	.85
7815T	.75	7924T	.95
7824T	.85		

7805K	1.29	7905K	1.39
7812K	1.29	7912K	1.39
7815K	1.29	7915K	1.39
7824K	1.29	7924K	1.39
7905T	.85		

T = TO-220
K = TO-3

CONNECTORS		
RS232	Male	3.00
RS232	Female	3.50
RS232	Female Right Angle	4.95
RS232	Hood	1.20
30 pin	Edge	2.49
44 pin	Edge	2.49
50 pin	Edge	2.69
86 pin	Edge	3.90
100 pin	ST	3.90
100 pin	W/W	4.90

CRYSTALS			
32.768 KHz	1.90	6.144	2.69
1.00 Hz	4.50	6.5536	2.69
1.8432	4.50	8.0	2.69
2.0	3.90	10.0	2.69
2.097152	3.90	12.0	2.69
2.4576	2.69	14.31818	2.69
3.2768	2.69	15.0	2.69
3.579545	2.69	16.0	2.69
4.0	2.69	17.430	2.69
5.0	2.69	18.0	2.69
5.0688	2.69	18.432	2.69
5.185	2.69	20.0	2.69
5.7143	2.69	22.1184	2.69
6.0	2.69		

8000			
8035	4.95	8251	4.39
8039	5.95	8253	6.89
8080A	3.89	8253-5	7.89
8085A	5.89	8255	4.39
8086	24.95	8255-5	5.19
8088	34.95	8257	7.89
8155	7.75	8259	6.85
8156	8.75	8272	39.00
8185	29.00	8275	29.00
8202	27.95	8279	8.89
8205	3.45	8279-5	9.89
8212	1.79	8282	6.49
8214	3.75	8283	6.49
8216	1.69	8284	5.49
8224	2.19	8286	6.49
8226	1.79	8287	6.49
8228	3.34	8288	24.95
8237	19.00	8289	39.00
8238	4.39	8741	34.95
8243	4.39	8748	14.95
8250	10.49	8755	29.95

STORE HOURS:

MON-FRI 8:30 A.M.-5:30 P.M.
SAT 10:00 A.M.-3:00 P.M.



TERMS: For shipping include \$2.00 for UPS Ground. \$3.00 for UPS Blue Label Air. \$10.00 minimum order. Bay Area residents add 6 1/2% Sales Tax. California residents add 6% Sales Tax. We reserve the right to limit quantities and substitute manufacturer. Prices subject to change without notice. Send SASE for complete list.

DoKau Computer Products, Inc.

2100 De La Cruz Blvd.
Santa Clara, CA 95050
(800) 538-8800

Calif. Residents
(800) 848-8008

Local Phone
(408) 988-0697

CALIFORNIA DIGITAL

Post Office Box 3097 B • Torrance, California 90503

★ FREE ★
Plastic library case supplied with all diskettes purchased from California Digital
\$19.95
New Low Price

Private labeled for California Digital by one of the most respected producers of magnetic media. Each diskette is certified double density at 40 tracks. To insure extended media life all diskettes are manufactured with a reinforced hub.
Each box of diskettes is supplied with a free plastic library case.
Soft sector CAL-501, Ten sector CAL-510

5 1/4" DISKETTES WITH LIBRARY CASE \$26.50

Your Choice
SCOTCH MEMOREX VERBATIM

Single Side Double Density

Soft Sector 10 Sector 16 Sector

SCOTCH	744D-0	744D-10	744D-16	26.50
MEMOREX	3481	3483	3485	26.50
VERBATIM	525-01	525-10	NA	26.50
MAXELL	MD1	MH1-10	MH1-16	29.85
DYSAN	104/1D	107/1D	NA	45.00

Double Side Double Density

SCOTCH	745-0	745-10	745-16	42.50
VERBATIM	550-01	550-10	NA	42.50
MAXELL	MD2-D	MH2-10D	MH2-16D	45.00
DYSAN	104/2D	107/2D	NA	49.50
DYSAN 96	204/2D	NA	NA	59.50

EIGHT INCH DISKETTES

Single Side Single Density

Single Side Double Density

SCOTCH	740-0	29.50	SCOTCH	741-0	39.00
MEMOREX	3060	29.50	MEMOREX	3090	35.00
DYSAN	3740/1	39.50	DYSAN	3740/D	57.50

Thirty Two Sector

Double Side Double Density

SCOTCH	740-32	29.50	SCOTCH	743-0	47.50
			MEMOREX	3114	39.50
			DYSAN	3740/2D	65.00

Fig. 8 File 7" 180° 50 disk. INC-250 18 9"
Fig. 8 File 6" 180° 50 disk. INC-200 22 9"
Fig. 8 File 5" 180° 50 disk. INC-150 24 9"
Scotch head clean up 6" 8" 8MM 45 24 5"
Plastic library cases 5" 8" 8MM 45 24 5"
50 pin socket CNE-225 2.95 5.50 1.59

POWER SUPPLIES & FANS

100 Watt line transformer 6V 30A 110V 5A AC relegate	EDP-1100	119.00
Class D switching supply for 5" 1/2" Widescreen or 8" ultra 12" wall & 5V CAD 34101	CAD 34101	119.00
Power One CP-240 linear for two 8" drives 5V 24V -12V (not printed)	POW 206	99.00
Auto. Switching supply 5V 3A 12V 1A 6" 12V 0.5A 115 230AC	ATC 12W	59.00
1/2 3/4 Comp. Terminal supply removed from sorting equipment	SPC PW1	14.95

23" composite monitor	UEC-1087	19.95
21" composite monitor	PAJ-4800	14.77
19" composite monitor	ER-2182	14.77
17" composite monitor	ROI-M02	9.95
15" composite monitor	ETR-126	14.77

23" composite monitor: Range monitor 115v 92watts 200 cph
21" composite monitor: 115v 20 watts 65 cph
19" composite monitor: 115v 9 watts 45 cph
17" composite monitor: 115v 14 watts 65 cph
15" composite monitor: 115v 9 watts 35 cph

MEMORY

16K DYNAMIC	2732 EPROM
1.95	4.95
4116 150ns.	450ns.
64K DYNAMIC	16K STATIC
6.95	4.95
4164 150ns.	6116 200ns.



2764 EPROM SALE \$5.95

DYNAMIC MEMORY

4027 1K dynamic 250ns	ICM-4027250	1.99	1.85	1.75
4116 150ns 16K	ICM-4116150	1.95	1.85	1.75
4116 200ns 16K	ICM-4116200	1.75	1.61	1.50
4164 150ns 64K 128 refresh	ICM-4164150	6.95	6.50	5.90
41256 150ns 256K	ICM-41256150			

STATIC MEMORY

21L02 200ns 1K static	ICM-21L02200	1.49	1.29	1.15
21L02 450ns 1K static	ICM-21L02450	1.29	1.15	.99
2112 450ns 2K static	ICM-2112450	2.99	2.85	2.75
2114 300ns 1K x 4	ICM-2114300	1.95	1.85	1.75
4044TMS 450ns 4K x 1	ICM-4044450	3.49	3.25	2.99
5257 300ns 4K x 8	ICM-5257300	2.50	2.25	1.95
6116 P4 200ns 2K x 8	ICM-6116200	4.95	4.80	4.65
6116 P3 150ns 2K x 8	ICM-6116150	5.95	5.75	5.60
6167/2167 100ns 16K x 1 (20 pin)	ICM-6167100	8.95	8.50	7.90

EPROMS

2708 450ns 1K x 8	ICE-2708	4.95	4.75	4.55
2716 450ns 2K x 8	ICE-2716	4.95	4.75	4.55
2716TMS 450ns Tri-wire	ICE-2716TMS	7.95	7.65	7.25
2732 450ns 4K x 8	ICE-2732	4.95	4.75	4.55
2732 450ns 4K x 8	ICE-2732DSO	8.50	8.00	7.60
2532 450ns 4K x 8	ICE-2532	10.50	9.90	9.50
2764 350ns 16K x 8	ICE-2764	5.95	5.65	5.37
27128 350ns 16K x 8	ICE-27128	29.95	28.32	27.46

CONNECTORS



S-100 Gold \$2.95 DB25P \$2.50

GOLD S-100 EDGE CARD CONNECTORS catalog each 10-99 100+
Imsa-s/1 250 CNE-1M5 2.95 2.50 2.19
Sullins Pin Reel CNE-H100 4.19 3.85 3.47
S-100 Wire W CNE-NV10 3.95 3.50 3.19
Altair 140 5/1 CNE-100A 4.95 4.50 4.19

.156" CENTER EDGE CARD CONNECTORS
20/44 Eyelet CNE-44E 2.50 2.15 1.95
43-72 Multi pin CNE-72S 6.60 6.15 5.75
36-72 Digi Pin CNE-72S 2.95 2.50 1.59
Other connectors available upon request

RIBBON CONNECTORS
DB25P male CND-25P 5.65 5.25 4.15
DB25S female CND-25S 5.95 5.59 4.50
57 30/30/60 male CMC-36P 7.89 6.75 5.92
57 30/30/60 female CMC-36S 7.99 6.75 5.92
20 pin socket CND-DS20 2.75 1.85 1.60
26 pin edge CND-DE26 4.95 3.50 2.70
29 pin socket CND-DS29 3.50 2.40 2.15
34 pin edge CND-DE34 4.95 3.50 3.50
34 pin socket CND-DS34 3.50 3.95 3.15
50 pin edge CND-DE50 5.95 4.60 4.00
50 pin socket CND-DS50 4.95 4.60 3.80

"D" TYPE catalog each 10-99 100+
DE9P female CND-9P 1.50 1.40 1.30
DE9S female CND-9S 2.25 2.00 1.30
DE16P female CND-16P 1.50 1.35 1.20
DA15S female CND-15P 2.35 2.10 2.90
DA15S hood CND-15H 2.10 2.35 1.30
DB25P male CND-25P 2.50 1.95 1.65
DB25S female CND-25S 3.35 2.75 1.85
DC37S hood CND-37H 1.35 1.15 1.77
DC37S female CND-37S 5.95 5.75 5.50
DC37S hood CND-37H 2.25 1.95 1.65
DD50P male CND-50P 5.50 5.10 4.75
DD50 hood CND-50H 2.60 2.40 2.10
Hardware 2-set CND-2HS 99 69 42

AMPHENOL / CENTRONICS TYPE
57 30/30/60 36/P CMC 36P 7.95 6.35 4.90
IEEE488, C color CND 24P 7.95 6.35 5.35

DISK DRIVE POWER CONNECTORS
8 pin D.C. CND-8DC 1.75 1.29 69
8 3AC Spt S CND-3SS 1.69 1.09 69
8 3AC Dts S CND-3DS 1.69 1.09 69
2 1/2 pin D.C. CND-2DC 1.75 1.19 99
3 pin D.M. recept CND-3DP 2.59 1.99 1.59

23" COMPOSITE MONITOR \$159
Ideal monitor for classroom demonstrations.
Ever try gathering a classroom of students around a 12" monitor? Here is your opportunity to purchase a 23" high resolution monitor at a reasonable price.
These units accept standard composite video signals generated by most personal computers including the Apple and IBM. Attach 4 your computer and in second you are shooting down Klingons in wide screen video.
MOT-8W22 35 lbs. Monitors are open frame and for safety should be enclosed. Wood grained enclosure for above \$35.00 additional. CAL-ENG23 15 lbs.

BLOWOUT SALE

\$179

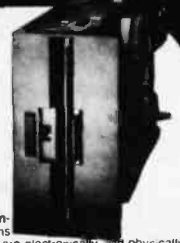

California Digital has recently participated in the purchase of several thousand Siemens FDD 100-8 floppy disk drives. These units are electronically and physically similar to that of the Shugart 801R. All units are new and shipped in factory sealed boxes. Manual and power connectors supplied free upon request. Your choice 115 Volt, 60 Hz. or 230 Volt, 50Hz.

REMEX DOUBLE SIDED \$219

California Digital has just purchased a large quantity of Remex RFD-4000 Eight inch double sided disk drives. Remex is the only double sided disk drive that has a double gimbal mounted head assembly that guarantees lower head tracking. This drive is mechanically solid. Remex has always been known for producing premiere products for the floppy disk market. The Remex company is a subsidiary of the Ex-cell-o Corporation, a Fortune 500 Company.

Eight Inch Single Sided

	One	Two	Ten
SHUGART SA801R	\$395	385	375
SIEMENS FDD100-8	179	179	169
TANDON 848-1 SLIMLINE	369	359	349

Eight Inch Double Sided

SHUGART SA851R	525	495	475
QUME DATA TRACK 8	525	495	475
MITSUBISHI M2894-63	459	449	409
REMEX RFD-4000	219	209	189
TANDON 848-2 SLIMLINE	485	475	465
SHUGART 860 THINLINE	569	549	539

Five Inch Single Sided

SHUGART SA200 3/4 Height	169	159	149
TANDON TM 100-1	119	119	Call

Five Inch Double Sided

SHUGART SA455 1/2 Height	259	249	239
SHUGART SA465 96TPI	289	279	269
TANDON TM 100-2	279	269	259
TANDON TM 101-4 96TPI	369	355	350

Three Inch Rigid Floppy

HITACHI-AMDEK	call for pricing
---------------	------------------

Five Inch Winchester

SEAGATE 406	6 Megabyte	695	675	650
SEAGATE 412	12 Megabyte	995	960	960
TANDON TM-503 14	Megabyte	895	860	795
WESTERN DYNAX	removable	995	960	950

Upon request, all drives are supplied with power connectors and manual

SPECIAL Tandon TM 100-1 \$119



Recent liquidation from a major manufacturer of data processing equipment allows California Digital the opportunity to offer these Tandon disk drives at a fraction of their original cost. Brand new, with 90 day guarantee. TAN-TM1001

TOLL FREE ORDER LINE
(800) 421-5041
TECHNICAL & CALIFORNIA
(213) 679-9001

Shipping: First five pounds \$3.00. Each additional \$5.00.
Foreign orders: 10% shipping. Express will be refunded.
California residents add 6% sales tax. COD's discouraged.
Open accounts extended to state supported educational institutions and companies with a "strong" Dun & Bradstreet.
Warehouse: 15608 Inglewood Blvd.
www.americanradiohistory.com



LIBERTY FREEDOM 50 \$475

The Liberty Freedom 50 terminal features detachable keyboard with 93 keys including 10 function keys, 15 graphic symbols, and DIP switch selectable character set for 7 foreign languages. The 12 inch etched non-glass green phosphor screen displays 24 rows by 80 characters in 7.63 mils with true descenders. Self-test and 25th data display row also included. Switch selectable baud rates from 110-19200 baud. Screen attributes do not use display memory, allowing operator to display up to 1920 characters. Emulates 5 popular CRT terminals for easy software configuration. Switch selectable between 115 and 230 volts have never seen a terminal with all these features for the incredibly low price of only \$475. LIB-F50 - 30 lbs.

DIABLO \$879



Now from the originator of the daisy wheel printer, the Diablo 620. Print speeds to 24 char/sec user selectable in directional printing, superscript, subscript, graphics and more. Plus standard RS-232C interfacing. Communication speeds to 1200 baud with a 1500 character print buffer. Software programmable absolute horizontal tabs makes reprint formatting easy. Over 20 different print widths are currently available. The 620 automatically selects the print spacing for 10, 12, 15 char/inch print widths. On sale separate available worldwide. DBL-620 50 lbs.

ECLIPSE 100 \$595



The Eclipse 100 is an industry rated IEE-696 S-100 19 slot mainframe. Equipped with a 500 watt forced modulator power supply to assure operation in the most severe environments. Provision for internally mounting a 3 1/2" Winchester disk drive. All card positions receive proper cooling from a filtered 85 cfm fan. Constructed from 304 brushed stainless steel is suitable for medical and process control applications. Use of the highest grade materials and state of the art construction techniques has made Eclipse Data Products the industry standard for quality and versatility in computer mainframes. EDP-100 50 lbs.

MORROW DESIGNS Micro Decision MD1 \$843



The Morrow Micro Decision offers one of the best values in small business computers. Standard features include 64K of RAM, 4MHz Z80 CPU, two RS232C serial ports, dual density floppy disk controller, capable of supporting four disk drives, and a 200 KiloByte 5 1/4" disk drive. The Micro Decision is delivered complete with CP/M 2.2 as well as Basic 6.0. Wordstar and other software packages. MD5 - 19 lbs.

Faraday Electronics IBM PC COMPATIBLE SINGLE BOARD COMPUTER \$479



The Faraday model 64 is a single board computer that is compatible with the IBM PC, plus incorporates several additional standard features: 64K of RAM memory, expandable to 256K. Centronics printer port and two RS-232C serial ports, also includes 3 expansion slots are included (upgradable to 9 slots). Other useful features include: IBM compatible keyboard interface 5087 socket, up to 32K of EPROM, 3 user available DMA channels, and 2 counter/timers. MS-DOS and CP/M 8.0 compatible. Board measures 8" by 12". Requires 5 volts and -12 volts. FAH-64

U.S. ROBOTICS 1200 BAUD MODEM \$419



The U.S. Robotics 212A/103 modem represents a major advance in 1200/300 baud modem technology. Proprietary 1200 baud LSI integrated circuit allows the U.S. Robotics 212A modem to maintain higher reliability over marginal phone lines. The U.S. Robotics 212A features auto dial, auto answer, command repeat and auto intelligent baud selection. U.S.R. 212A - \$419.00 - 2 lbs. Other excellent values in direct connect modems: Signalmart Mark II at \$74.95 and the Universal Data 1200 baud at only \$69.00.

PRINTERS \$269

Star Gemini 10 ribbon & tractor 100 char/sec parallel Star Gemini 15 100 char/sec 15 paper Star Gemini 200FT tractor A tractor OKI 82A 419.00 OKI 92A 595.00 OKI 83A 595.00 OKI 84A 629.00 OKI 930 1995.00 Epson FB80 160 char/sec with graphics the tractor OKI 2350 tractor 150 char/sec Epson FB80 160 char/sec with graphics 15 paper NEC GP 24 parallel 15 paper graphics Anadix 9500A high speed 15 paper Anadix 9521A high speed 15 paper graphics Datasouth 180 high speed 180 cps 15 printer 7100 correspondence quality 80 char/sec Proton 8510 parallel 15 paper Printer 8510 serial 15 paper Printer II parallel 15 paper graphics Printer II serial 15 paper graphics Printmate PE600 ultra high speed 600 lines per minute 15 paper graphics Printmate PE600 ultra high speed 600 lines per minute 15 paper graphics

TERMINALS \$795

The Wyse 100 features die cast aluminum case, 102 key keyboard and non-glare 26 line green phosphor video display. Split screen both horizontal an vertical makes the WY-100 unusually user friendly. This unique terminal is perfect to enhance any business system.



Freedom 50, split screen, detachable keyboard, Visual 50, detachable keyboard selectable settings. Visual 50 Green screen. Visual 330, emulates DEC, DCL, LSI green Ampco Dialogue 125 green screen two page, func. keys Ampco Dialogue 125 amber screen, two page, func. keys Wyse 100, horiz. & vert. split screen, metal enclosure Wyse 300, high char. display, split screen Teletype 910 50, block mode Teletype 925, detachable keyboard, 22 function keys Teletype 930, graphic char. split screen, 22 func. Teletype 970, 14 green screen, 130 column European Zenith 20 terminal, VT52 compatible, detachable keyboard ADDS Viewpoint A1, detachable keyboard ADDS Viewpoint A2, w/cursor

INNER ACCESS CORPORATION S-100 EPROM & MICROPROCESSOR PROGRAMMER \$495

Programs Proms: 2708 • 2716 • 2732 2732A • 2764 • 27128 Programs Microcomputers 8748 • 8748H • 8749H • 8751 Programs EE/PROMS XICOR X2804 & X2816 Programs Microcontrollers 8741 • 8742



• S-100, IEEE-696 extra height card Increases accessibility to switches and zero insertion PROM sockets. • Does not require personality modules or off board cables. • Supplied with full CP/M based EPROM programming software. • Features Intel fast programming algorithms. • On board programming power supply. • Equipped with four zero insertion programming sockets.

WORD PROCESSING PRINTERS \$279.95

NEC 7730 55 char/sec, dot matrix interface NEC 7730 55 char/sec, par interface Shiber freed EXP500 13 char/sec, par interface Shiber freed EXP500 17 char/sec, par interface Librite 630 40 char/sec serial Librite 630 40 char/sec serial Librite 630 professional spacing, horiz. & vert. tab 20 cps. Dasher HRI 40 char/sec, dot matrix interface Brother HRI 40 char/sec, dot matrix interface StarWriter F10 parallel, 40 char/sec StarWriter F10 serial, 40 char/sec

MICROSWITCH ASCII KEYBOARD \$79

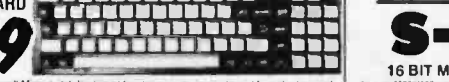

This Honeywell Microswitch keyboard has been recently purchased from the terminal division of Lear Siegler. Each keyboard contains 81 high reliability IBM Effect keys. Teletype, Xerox, & Bart terminals. Complete with documentation and schematics. MIC-81SDS 9 lbs.

S-100 BOARDS

16 BIT MICROPROCESSORS		STATIC MEMORY BOARDS	
Goodbit 8008/8081 microcomputer 16 bit	G81-6867 579.00	Goodbit Ram 16, 64K, 160 data extend	G81-R16 459.00
Goodbit CP16 bit & 8088 address 16 meg	G81-6868 525.00	Goodbit Ram 21, 128K byte 16 data extend	G81-R17 459.00
Goodbit 8088/8088 microprocessor 16 bit	G81-6869 429.00	Goodbit Ram 21, 128K byte 16 data extend	G81-R18 459.00
Lomax Data Systems Lighting 8088 16 bit	LDM-8088 429.00	Goodbit Ram 21, 128K byte 16 data extend	G81-R19 459.00
Wayne 811 495.00		Goodbit Ram 21, 128K byte 16 data extend	G81-R20 459.00
Advanced Digital, Phipps & Gair	AMD-750 750.00	Goodbit Ram 21, 128K byte 16 data extend	G81-R21 459.00
Telebit 8088/8088 microprocessor 16 bit	TEL-8088 675.00	Goodbit Ram 21, 128K byte 16 data extend	G81-R22 459.00
Telebit 8088/8088 microprocessor 16 bit	TEL-8088 675.00		
SINGLE BOARD COMPUTERS		DYNAMIC MEMORY BOARDS	
Wayne 811 495.00		California Computer 2066, 64K main memory	CCS-2066 795.00
Advanced Digital, Phipps & Gair	AMD-750 750.00		
Telebit 8088/8088 microprocessor 16 bit	TEL-8088 675.00		
Telebit 8088/8088 microprocessor 16 bit	TEL-8088 675.00		
8 BIT MICROPROCESSORS		INTERFACE BOARDS	
Goodbit 800 24 bit extended addressing	G81-750 750.00	Goodbit Interface II 3 serial 3 parallel ports	G81-I23A 239.00
California Computer 2066 micro	CCS-210 275.00	Goodbit Interface III with serial ports	G81-I23B 269.00
California Computer 2066 micro	CCS-210 275.00	Goodbit Interface III with serial ports	G81-I23C 269.00
California Computer 2066 micro	CCS-210 275.00	Goodbit Interface III with serial ports	G81-I23D 269.00
California Computer 2066 micro	CCS-210 275.00	Goodbit Interface III with serial ports	G81-I23E 269.00
California Computer 2066 micro	CCS-210 275.00	Goodbit Interface III with serial ports	G81-I23F 269.00
California Computer 2066 micro	CCS-210 275.00	Goodbit Interface III with serial ports	G81-I23G 269.00
California Computer 2066 micro	CCS-210 275.00	Goodbit Interface III with serial ports	G81-I23H 269.00
California Computer 2066 micro	CCS-210 275.00	Goodbit Interface III with serial ports	G81-I23I 269.00
California Computer 2066 micro	CCS-210 275.00	Goodbit Interface III with serial ports	G81-I23J 269.00
California Computer 2066 micro	CCS-210 275.00	Goodbit Interface III with serial ports	G81-I23K 269.00
California Computer 2066 micro	CCS-210 275.00	Goodbit Interface III with serial ports	G81-I23L 269.00
California Computer 2066 micro	CCS-210 275.00	Goodbit Interface III with serial ports	G81-I23M 269.00
California Computer 2066 micro	CCS-210 275.00	Goodbit Interface III with serial ports	G81-I23N 269.00
California Computer 2066 micro	CCS-210 275.00	Goodbit Interface III with serial ports	G81-I23O 269.00
California Computer 2066 micro	CCS-210 275.00	Goodbit Interface III with serial ports	G81-I23P 269.00
California Computer 2066 micro	CCS-210 275.00	Goodbit Interface III with serial ports	G81-I23Q 269.00
California Computer 2066 micro	CCS-210 275.00	Goodbit Interface III with serial ports	G81-I23R 269.00
California Computer 2066 micro	CCS-210 275.00	Goodbit Interface III with serial ports	G81-I23S 269.00
California Computer 2066 micro	CCS-210 275.00	Goodbit Interface III with serial ports	G81-I23T 269.00
California Computer 2066 micro	CCS-210 275.00	Goodbit Interface III with serial ports	G81-I23U 269.00
California Computer 2066 micro	CCS-210 275.00	Goodbit Interface III with serial ports	G81-I23V 269.00
California Computer 2066 micro	CCS-210 275.00	Goodbit Interface III with serial ports	G81-I23W 269.00
California Computer 2066 micro	CCS-210 275.00	Goodbit Interface III with serial ports	G81-I23X 269.00
California Computer 2066 micro	CCS-210 275.00	Goodbit Interface III with serial ports	G81-I23Y 269.00
California Computer 2066 micro	CCS-210 275.00	Goodbit Interface III with serial ports	G81-I23Z 269.00
California Computer 2066 micro	CCS-210 275.00	Goodbit Interface III with serial ports	G81-I23AA 269.00
California Computer 2066 micro	CCS-210 275.00	Goodbit Interface III with serial ports	G81-I23AB 269.00
California Computer 2066 micro	CCS-210 275.00	Goodbit Interface III with serial ports	G81-I23AC 269.00
California Computer 2066 micro	CCS-210 275.00	Goodbit Interface III with serial ports	G81-I23AD 269.00
California Computer 2066 micro	CCS-210 275.00	Goodbit Interface III with serial ports	G81-I23AE 269.00
California Computer 2066 micro	CCS-210 275.00	Goodbit Interface III with serial ports	G81-I23AF 269.00
California Computer 2066 micro	CCS-210 275.00	Goodbit Interface III with serial ports	G81-I23AG 269.00
California Computer 2066 micro	CCS-210 275.00	Goodbit Interface III with serial ports	G81-I23AH 269.00
California Computer 2066 micro	CCS-210 275.00	Goodbit Interface III with serial ports	G81-I23AI 269.00
California Computer 2066 micro	CCS-210 275.00	Goodbit Interface III with serial ports	G81-I23AJ 269.00
California Computer 2066 micro	CCS-210 275.00	Goodbit Interface III with serial ports	G81-I23AK 269.00
California Computer 2066 micro	CCS-210 275.00	Goodbit Interface III with serial ports	G81-I23AL 269.00
California Computer 2066 micro	CCS-210 275.00	Goodbit Interface III with serial ports	G81-I23AM 269.00
California Computer 2066 micro	CCS-210 275.00	Goodbit Interface III with serial ports	G81-I23AN 269.00
California Computer 2066 micro	CCS-210 275.00	Goodbit Interface III with serial ports	G81-I23AO 269.00
California Computer 2066 micro	CCS-210 275.00	Goodbit Interface III with serial ports	G81-I23AP 269.00
California Computer 2066 micro	CCS-210 275.00	Goodbit Interface III with serial ports	G81-I23AQ 269.00
California Computer 2066 micro	CCS-210 275.00	Goodbit Interface III with serial ports	G81-I23AR 269.00
California Computer 2066 micro	CCS-210 275.00	Goodbit Interface III with serial ports	G81-I23AS 269.00
California Computer 2066 micro	CCS-210 275.00	Goodbit Interface III with serial ports	G81-I23AT 269.00
California Computer 2066 micro	CCS-210 275.00	Goodbit Interface III with serial ports	G81-I23AU 269.00
California Computer 2066 micro	CCS-210 275.00	Goodbit Interface III with serial ports	G81-I23AV 269.00
California Computer 2066 micro	CCS-210 275.00	Goodbit Interface III with serial ports	G81-I23AW 269.00
California Computer 2066 micro	CCS-210 275.00	Goodbit Interface III with serial ports	G81-I23AX 269.00
California Computer 2066 micro	CCS-210 275.00	Goodbit Interface III with serial ports	G81-I23AY 269.00
California Computer 2066 micro	CCS-210 275.00	Goodbit Interface III with serial ports	G81-I23AZ 269.00
California Computer 2066 micro	CCS-210 275.00	Goodbit Interface III with serial ports	G81-I23BA 269.00
California Computer 2066 micro	CCS-210 275.00	Goodbit Interface III with serial ports	G81-I23BB 269.00
California Computer 2066 micro	CCS-210 275.00	Goodbit Interface III with serial ports	G81-I23BC 269.00
California Computer 2066 micro	CCS-210 275.00	Goodbit Interface III with serial ports	G81-I23BD 269.00
California Computer 2066 micro	CCS-210 275.00	Goodbit Interface III with serial ports	G81-I23BE 269.00
California Computer 2066 micro	CCS-210 275.00	Goodbit Interface III with serial ports	G81-I23BF 269.00
California Computer 2066 micro	CCS-210 275.00	Goodbit Interface III with serial ports	G81-I23BG 269.00
California Computer 2066 micro	CCS-210 275.00	Goodbit Interface III with serial ports	G81-I23BH 269.00
California Computer 2066 micro	CCS-210 275.00	Goodbit Interface III with serial ports	G81-I23BI 269.00
California Computer 2066 micro	CCS-210 275.00	Goodbit Interface III with serial ports	G81-I23BJ 269.00
California Computer 2066 micro	CCS-210 275.00	Goodbit Interface III with serial ports	G81-I23BK 269.00
California Computer 2066 micro	CCS-210 275.00	Goodbit Interface III with serial ports	G81-I23BL 269.00
California Computer 2066 micro	CCS-210 275.00	Goodbit Interface III with serial ports	G81-I23BM 269.00
California Computer 2066 micro	CCS-210 275.00	Goodbit Interface III with serial ports	G81-I23BN 269.00
California Computer 2066 micro	CCS-210 275.00	Goodbit Interface III with serial ports	G81-I23BO 269.00
California Computer 2066 micro	CCS-210 275.00	Goodbit Interface III with serial ports	G81-I23BP 269.00
California Computer 2066 micro	CCS-210 275.00	Goodbit Interface III with serial ports	G81-I23BQ 269.00
California Computer 2066 micro	CCS-210 275.00	Goodbit Interface III with serial ports	G81-I23BR 269.00
California Computer 2066 micro	CCS-210 275.00	Goodbit Interface III with serial ports	G81-I23BS 269.00
California Computer 2066 micro	CCS-210 275.00	Goodbit Interface III with serial ports	G81-I23BT 269.00
California Computer 2066 micro	CCS-210 275.00	Goodbit Interface III with serial ports	G81-I23BU 269.00
California Computer 2066 micro	CCS-210 275.00	Goodbit Interface III with serial ports	G81-I23BV 269.00
California Computer 2066 micro	CCS-210 275.00	Goodbit Interface III with serial ports	G81-I23BW 269.00
California Computer 2066 micro	CCS-210 275.00	Goodbit Interface III with serial ports	G81-I23BX 269.00
California Computer 2066 micro	CCS-210 275.00	Goodbit Interface III with serial ports	G81-I23BY 269.00
California Computer 2066 micro	CCS-210 275.00	Goodbit Interface III with serial ports	G81-I23BZ 269.00
California Computer 2066 micro	CCS-210 275.00	Goodbit Interface III with serial ports	G81-I23CA 269.00
California Computer 2066 micro	CCS-210 275.00	Goodbit Interface III with serial ports	G81-I23CB 269.00
California Computer 2066 micro	CCS-210 275.00	Goodbit Interface III with serial ports	G81-I23CC 269.00
California Computer 2066 micro	CCS-210 275.00	Goodbit Interface III with serial ports	G81-I23CD 269.00
California Computer 2066 micro	CCS-210 275.00	Goodbit Interface III with serial ports	G81-I23CE 269.00
California Computer 2066 micro	CCS-210 275.00	Goodbit Interface III with serial ports	G81-I23CF 269.00
California Computer 2066 micro	CCS-210 275.00	Goodbit Interface III with serial ports	G81-I23CG 269.00
California Computer 2066 micro	CCS-210 275.00	Goodbit Interface III with serial ports	G81-I23CH 269.00
California Computer 2066 micro	CCS-210 275.00	Goodbit Interface III with serial ports	G81-I23CI 269.00
California Computer 2066 micro	CCS-210 275.00	Goodbit Interface III with serial ports	G81-I23CJ 269.00
California Computer 2066 micro	CCS-210 275.00	Goodbit Interface III with serial ports	G81-I23CK 269.00
California Computer 2066 micro	CCS-210 275.00	Goodbit Interface III with serial ports	G81-I23CL 269.00
California Computer 2066 micro	CCS-210 275.00	Goodbit Interface III with serial ports	G81-I23CM 269.00
California Computer 2066 micro	CCS-210 275.00	Goodbit Interface III with serial ports	G81-I23CN 269.00
California Computer 2066 micro	CCS-210 275.00	Goodbit Interface III with serial ports	G81-I23CO 269.00
California Computer 2066 micro	CCS-210 275.00	Goodbit Interface III with serial ports	G81-I23CP 269.00
California Computer 2066 micro	CCS-210 275.00	Goodbit Interface III with serial ports	G81-I23CQ 269.00
California Computer 2066 micro	CCS-210 275.00	Goodbit Interface III with serial ports	G81-I23CR 269.00
California Computer 2066 micro	CCS-210 275.00	Goodbit Interface III with serial ports	G81-I23CS 269.00
California Computer 2066 micro	CCS-210 275.00	Goodbit Interface III with serial ports	G81-I23CT 269.00
California Computer 2066 micro	CCS-210 275.00	Goodbit Interface III with serial ports	G81-I23CU 269.00
California Computer 2066 micro	CCS-210 275.00	Goodbit Interface III with serial ports	G81-I23CV 269.00
California Computer 2066 micro	CCS-210 275.00	Goodbit Interface III with serial ports	G81-I23CW 269.00
California Computer 2066 micro	CCS-210 275.00	Goodbit Interface III with serial ports	G81-I23CX 269.00
California Computer 2066 micro	CCS-210 275.00	Goodbit Interface III with serial ports	G81-I23CY 269.00
California Computer 2066 micro	CCS-210 275.00	Goodbit Interface III with serial ports	G81-I23CZ 269.00
California Computer 2066 micro	CCS-210 275.00	Goodbit Interface III with serial ports	G81-I23DA 269.00
California Computer 2066 micro	CCS-210 275.00	Goodbit Interface III with serial ports	G81-I23DB 269.00
California Computer 2066 micro	CCS-210 275.00	Goodbit Interface III with serial ports	G81-I23DC 269.00
California Computer 2066 micro	CCS-210 275.00	Goodbit Interface III with serial ports	G81-I23DD 269.00
California Computer 2066 micro	CCS-210 275.00	Goodbit Interface III with serial ports	G81-I23DE 269.00
California Computer 2066 micro	CCS-210 275.00	Goodbit Interface III with serial ports	G81-I23

IBM Specials

Advanced Operating Systems	
The Programmer	\$129
Applied Software	
Versaform	\$249
Ashton-Tate	
dBase II (CP/M86)	\$419
dBase II (MS DOS)	\$419
Continental Software	
The Home Accountant Plus	\$ 95
1st Class Mail	\$ 79
Computer Software Technology	
WordPC	\$ 49
Davidson & Associates	
Speed Reader	\$ 49
Datamost	
Real Estate Investment Program	\$ 79
Write-On	\$ 85
Comprehensive Software	
PC Tutor	\$ 55
Denver Software	
Executive Accounting System (128K)	\$469
Eagle Software	
Money Decisions	\$129
Howard Software	
Real Estate Analyzer II	\$159
Tax Preparer 1983	\$159
Information Solutions	
25:01	\$ 65
Innovative Software	
T.I.M. III	\$299
IUS	
Easy Filer	\$239
Easy Writer II	\$209
Easy Planner	\$159
Accounts Receivable	\$369
Accounts Payable	\$369
General Ledger	\$369
Financial Management Series	\$899
Micro Lab	
The Tax Manager	\$159
Micro Pro	
Wordstar	\$299
Mailmerge	\$159
Spellstar	\$109
Infostar	\$299
Reportstar	\$209
North American Business Systems	
Answer	\$159
PBL Corporation	
Personal Investor	\$ 89
Peachtree	
General Ledger	\$329
Accounts Receivable	\$329
Accounts Payable	\$329
Peach Pak (GLAR/AP)	\$389
Software Publishing	
PFS Report	\$ 89
PFS File	\$ 89
Digital Research	
Concurrent CP/M 86	\$209
C Basic 86	\$125
Pasca/MT + 86	\$239
Speed Programming Package 86	\$125
CIS Cobol 86	\$489
Peter Norton Computing	
Norton Utilities	\$ 55
Select	
Select Word Processing System	\$299
Softword Systems	
Wordmaker	\$289
Sorcim/ISA	
Supercalc	\$179
Superwriter	\$239
Spellguard	\$125
Southeastern	
Data Capture	\$ 75
Visicorp	
Visicalc (256K)	\$165
Desktop Plan 1	\$199
Visitrend/Plot	\$199
Visifile	\$199
Visidex	\$165
Visischedule	\$199
Business Forecasting Model	\$ 69

Prices That Won't New Products of Your Monitors

★ ★ Corona Desktop Computer ★ ★
IBM Compatible Includes 2 320K drives, 128K memory. Graphics, serial/parallel ports, high resolution monitor, MS DOS, CP/M-86, BASIC, Multimate wordprocessing.
\$2595

★ ★ Corona Desktop Computer ★ ★
Same as above with one 320K floppy and one 10 megabyte hard drive.
\$3995

★ ★ Corona Portable Computer ★ ★
IBM compatible/2 320 drives. Same components as above.
\$2395

★ ★ Corona Portable Computer ★ ★
With 1 320 drive & 10 MG hard drive.
\$4295

★★ Specials of the Month ★★

Corona Hard Disk Subsystem 5 MG	\$1399
Corona 5 MG External	\$1729
Corona 10 MG Internal	\$1819
Corona 10 MG External	\$2149
Verbatim Disks (S/D w/Library Case)	\$ 27
Box of Maxell Disks (D/D)	\$ 39
Flip n' Sort Diskette Box (Holds 50 Disks)	\$ 21
Elephant Disks	\$ 20
USI Amber Monitor	\$ 149
Color 1 Plus Monitor	\$299
Quadboard 256K Installed	\$399
Quad 512 + (512K Installed)	\$599
Mark VI Modem	\$179
AST Megapius II (256K Installed)	\$539
Lemon Surge Protector	\$ 39
Orange Surge Protector	\$ 95

Amdek	
Color II	\$ 679
Color III	\$ 399
Color IV (RGB Analog Input)	\$1029
Amdisk 3	\$ 729
Amplot	\$ 769
Amdek V310 Green	\$ 179

NEC	
NEC JB 1201M	\$ 169

Transtar	
Transtar 20	\$ 139

Quadram Quadchrome

- Hi-Res RGB Monitor
- Non-Glare Screen
- 690 x 240 Resolution

**CALL FOR
PRICE!**

Peripherals

Kraft Joystick	45
TG Joystick	\$ 39
TG Trackball	\$ 39
Microsoft 64K Ramcard	\$ 239
Microsoft 256K Ramcard	\$ 589
Hayes Smartmodem 300	\$ 209
Hayes Smartmodem 1200	\$ 499
Hayes Smartmodem 1200B	\$ 399
Hayes Smartcom II Terminal Pk.	\$ 72
Anchor Automation Mark VI Modem	\$ 179
Quadram Microfazer w/Power Supply	\$ 149
Trackball	\$ 59
Analog Joystick	\$ 49
IBM Interface Card	\$ 45
Versawriter Graphics Tablet	\$ 239



Call Toll Free
1-800-634-6766

Order Line Only

Information & Order Inquiries (702) 369-5523

CP/M 8"

Digital Research		SuperSort	\$145
CBasic	\$ 99	SpellStar	\$145
CB-80	\$309	WordMaster	\$ 95
Pascal/MT +	\$219	CalcStar	\$ 89
Speed Programming Package	\$129	3 Pak (Word/Mail/SpellStar)	\$489
CIS Cobol	\$499	2 Pak (WordStar and MailMerge)	\$369
Access Manager	\$189	2 Pak (WordStar and SpellStar)	\$369
Display Manager	\$253	InfoStar	\$289
		ReportStar	\$209
Micropro International		Sorcim Corporation	
WordStar	\$259	SuperCalc	\$185
DataStar	\$179	Spellguard	\$123
MailMerge	\$139		

NEWLY ARRIVED IBM Personal Computer



Includes 64K IBM-PC with 2 320 KB floppy disk drives, controller color graphics card, monochrome monitor

\$2839

Take A Byte Out Budget.

Printers



Atari

NEC	
NEC 8023A	\$ 439
NEC 3530	\$1599
NEC 7710	\$2059
NEC 7730	\$2059
NEC 3550	\$1899

Diablo	
Diablo 620R (25CPS)	\$ 949
Diablo 630R (40CPS)	\$1729
Diablo 630KSR (40CPS)	\$2429

Epson	
FX80	\$ 599
FX100FT	\$ 799

Smith Corona	
TP-1 Parallel	\$ 499

Okidata	
ML82A	\$ 419
ML83A	\$ 649
ML84P	\$ 979
ML84S	\$1089
ML92	\$ 489
ML93	\$ 869

IDS	
Microprism 80	\$ 549
Prism 132	\$1399
(with Sheetfeed & Graphics)	
Prism 132	\$1589
(with Sheetfeed, Graphics & Color)	
Prism to IBM Cable	\$ 48

Citoh	
8510 Prowriter	\$ 365
F10 Starwriter	\$1199
F10 Printmaster	\$1599

Mannesmann Tally	
MT 180L	\$ 599
MT 1802 (Parallel)	\$1559
MT 1805 (Serial)	\$1559

Gemini	
Gemini 10	\$ 319
Gemini 15	\$ 479

Qume	
Qume Sprint 11 +	\$1349
Tractor Feed	\$ 175
Printer Interface	\$ 79

1200 XL \$419
with factory rebate
800 48K \$299
with factory rebate
400 16K \$159
with factory rebate

1010 Recorder	\$ 72
410 Recorder	\$ 72
810 Disk Drive	\$419
1025 Printer	\$409
830 Modem	\$145
850 Interface	\$159
481 Entertainer	\$ 64
482 Educator	\$110
483 Programmer	\$ 52
484 Communicator	\$289
853 16K Ram	\$ 74
The Bookkeeper Kit	\$165
CX4104 Mailing List	\$ 19
CX404 Word Processor	\$102
CXL4007 Music Composer	\$ 42
Programming 2 & 3	\$ 22
Conversational Languages	\$ 42
CX4018 Pilot	\$ 55
CX405 Pilot	\$ 92
CXL4003 Assembler Editor	\$ 42
CX8126 Microsoft Basic	\$ 62

Business & Utilities

Visicalc	\$169
Mail Merge	\$ 20
Data Perfect	\$ 75
Letter Perfect	\$105
Text Wizard	\$ 65
Datasm 65 2.0	\$ 59
File Manager 800 +	\$ 65
Syn Assembler	\$ 34
Page 6	\$ 20
Atari World	\$ 39
K-Dos	\$ 59
Micropainter	\$ 23
Color Print	\$ 27
Lisp Interpreter	\$ 79
Bishops Square	\$ 20
Graphic Master	\$ 27
Graphic Generator	\$ 17
Basic Compiler	\$ 65
Computari's Financial Wizard	\$ 45
Color Accountant	\$ 65
Datalink	\$ 27
File II 2 System	\$ 34
Diskette Inventory System	\$ 17
P.M.P. Property Management	\$179

Programming Techniques

Display Lists	\$ 17
Horiz/Vert Scroll	\$ 17
Page Flipping	\$ 17
Basics of Animation	\$ 17
Player Missile Graphics	\$ 24
Sound	\$ 24
Data Files	\$ 24



1095 E. Twain (702) 796-0296
Las Vegas, Nevada 89109

Call Toll Free

1-800-634-6766

Order Line Only

Information & Order Inquiries (702) 369-5523

We accept VISA and MasterCard

Mon. — Fri. 8 A.M. to 6 P.M. — Sat. 9 A.M. to 6 P.M.

Dealers' Inquiries Invited

Apple Utilities & Business

Screenwriter II	\$ 82
Visicalc 3.3	\$165
Visischedule	\$199
Visitrend/Visiplot	\$199
The Word Handler	\$129
Magic Window II	\$ 95
Magic Mailer	\$ 45
Magic Words	\$ 45
Real Estate Analyzer II	\$119
Supercalc	\$165
PFS: Report (New)	\$ 85
PFS:	\$ 85
PFS: Graph	\$ 85
The General Manager	\$ 97
D.B. Master	\$145
Pie Writer	\$ 95
Wordstar	\$299
Datafax	\$129
Datalink	\$ 65
The Home Accountant	\$ 48
Payroll Manager	\$199
Pie Writer/Multi 80 column	\$ 95
Pro-Easywriter/Mail Combo	\$209
Executive Briefing System	\$139
The Sensible Speller	\$ 79
Mail Merge	\$159
Spellstar	\$119
Calstar	\$119
First Class Mail	\$ 49
E-Z Ledger	\$ 45
The Dictionary	\$ 65
Versawriter Pak 1	\$ 27
Versawriter Pak 2	\$ 27
Personal Investor	\$ 95
General Ledger	\$239
Accounts Receivable	\$239
Accounts Payable	\$239
Executive Secretary	\$159
Executive Speller	\$ 55
TASC Compiler	\$119
Basic Compiler	\$ 65
Link Video Apple II	\$105
Link Video Apple III	\$139
Bag of Tricks	\$ 27
A.L.D.S.	\$ 89
S.A.M.	\$ 85
Super Disk Copy III	\$ 20
The Artist	\$ 65
3-D Supergraphics	\$ 27
Program Line Editor	\$ 27

Hit List

Cyborg	\$22
Crisis Mountain	\$23
Cytron Masters	\$27
S.E.U.S.	\$27
Knight of Diamonds	\$23
Way Out	\$27
Zaxxon	\$27
S.A.G.A. Adventure	Ea \$27
Serpentine	\$23
Chopflifer	\$23
Frogger	\$23
Sea Fox	\$20
Temple of Apshai	\$27
Ultima	\$27
Zork I	\$27
Zork II	\$27
Zork III	\$27
Castle Wolfenstein	\$20
Wiz & Princess	\$22
Ulysses & The Golden Fleece	\$23
Wizardy	\$34
Tigers In The Snow	\$27
Deadline	\$34
Bandits	\$23
Starcross	\$27
Aztec	\$27
Mask of the Sun	\$27
Pie Man	\$20
Miner 2049er	\$29
Wavy Navy	\$23
Ultima II	\$39
Dark Crystal	\$27
Millionaire	\$55
Hi Res Secret	\$79
Police Artist	\$23
Suspended	\$35

We Carry the Full Line of AST Research and Quadram Multi-Function Boards CALL FOR BEST PRICING

ORDERING INFORMATION AND TERMS:
For fast delivery send cashier checks, money orders or direct bank wire transfers. Personal and company checks allow 3 weeks to clear. C.O.D. orders (\$3.00 minimum) and 1% of all orders over \$300. School purchase orders welcome. Prices reflect a cash discount only and are subject to change. Please enclose your phone number with any orders.

SHIPPING: Software (\$2.50 minimum). Shipping — Hardware (please call). Foreign orders APO & FPO orders — \$10 minimum and 15% of all orders over \$100. Nevada residents add 5 3/4% sales tax. All goods are new and include factory warranty. Due to our low prices, all sales are final. All returns must have a return authorization number. Call 702-369-5523 to obtain one before returning goods for replacement. All returned merchandise is subject to a restocking fee and must come with their original packaging in order to be accepted. NO returns permitted after 21 days from shipping date.

ADVANCED COMPUTER PRODUCTS

SEND \$2.00 FOR 1983 CATALOG

MICROPROCESSORS

Z8001	\$99.00	8008-1	\$14.95	8002P	14.95
Z8002	69.00	8008-2	9.99	8002	14.95
Z8003	9.95	2901A	14.95	8039	12.95
Z8004	11.95	9900-L	49.95	8073N	34.95
F8 (3850)	16.95	6M602	9.95	8755	49.95
2650	16.95	6502A	9.95	8748	49.95
1802	7.95	IM610	29.95	6709	30.00
8080A	4.75	6800	11.75	8086	49.95
8085	14.95	6800B	19.95	8086	129.95

16K Apple™ Ramcard

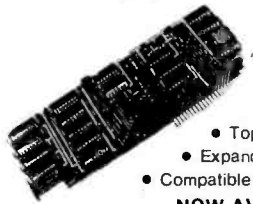

LIST 195
ACP
\$59.95

- Full 1 year warranty
- Top quality — gold fingers
- Expand Apple II 48K to 64K
- Compatible with Z-80 SoftCard™

NOW AVAILABLE
Apple IIe 64K Add-in Memory
with 80 Columns \$149.95

32K STATIC RAM



2 or 4 MHz
Expandable
Uses
2114L's
16K 4 MHz Kit \$159.95
16K 4 MHz AST \$219.95
32K 4 MHz Kit \$39.00
32K 4 MHz AST \$39.00
BARE BOARD 39.95
Bare Board w/all parts less mem. 99.95

64K CMOS RAMCARD



IEEE
Compatible
Uses
Low Power
6116 IC's
5 Volt
Single Supply
Assm and Tested
\$269.00

REPEAT OF SELL-OUT 58 Key Unencoded Keyboard



\$19.95 ea.

This is a new 58 key Terminal Keyboard manufactured by a major manufacturer. It is unencoded with SPST keys unattached to any PC board. Solid molded plastic 11" x 4" base.

INTEL 4K STATIC RAMS

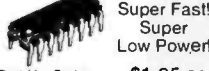

Super Fast!
Super
Low Power!
Part No. 2147 \$1.95 ea.

Unencoded Key Pad



15 key Keypad with 1-10 keys and tab, return, (-), (.) and (,).
Only \$9.95 ea.

STEPPER MOTOR

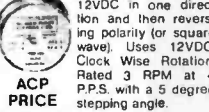

Operates by applying 12VDC in one direction and then reversing polarity (or square wave). Uses 12VDC, Clock Wise Rotation, Rated 3 RPM at 4 P.P.S. with a 5 degree stepping angle.

UV "EPROM" ERASER

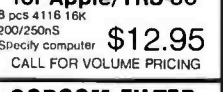

Model DE-4
\$89.95
Holds 4 EPROM's at a time.
Model S-52T \$325.00

RS232 SIGNAL TESTER



COEX RS232
Line Tester
(7) LED Indicators
Only \$24.95
Other Styles Also Available

16K Memory Expansion Kits



for Apple/TRS-80
8 pcs 4116 16k
200/250S
Specify computer \$12.95
CALL FOR VOLUME PRICING

INTEL CODEC IC



P/N 2910A
For Digital Voice
\$9.95 ea.
For Filter P/N 2912A... \$4.95 ea.

CORCOM FILTER



Popular CORCOM Filter
6 amps
Compatible Line Cord Add... \$3.50

SURGE SUPPRESSOR "Surgeonics"



Power Sentry
15 Amps 250 Volts
transient suppression
ACP
Low Price \$39.95

9 pcs 4164 D-RAM \$50.00

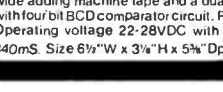

AMD MODEM IC
P/N AM7910
1200Baud
5 Volts
Special ACP Price \$99.00

3L WIREWRAP SOCKETS (GOLD)



8 pin WW .16 .15 .14
14 pin WW .20 .19 .18
16 pin WW .29 .28 .27
20 pin WW .34 .32 .30
22 pin WW .38 .37 .34
24 pin WW .45 .44 .43
28 pin WW .55 .54 .53
40 pin WW .80 .80 .80

CONNECTORS

DB25P (RS232)	\$3.25
DB25S Female	3.75
Hood	1.25
Set with Hood, Sale	7.50
22/44 S/T, KIM	2.95
43/86 S/T, MOT	6.50
50/100 S-100 Connector W/W	4.95
50/100 S-100 Connector S/T	3.95

PARALLEL ALPHA NUMERIC PRINTER

19 Column Printer prints 16 numerical columns plus 3 columns which have math, alpha and other notations. Each wheel has 12 positions with position 12 blank. Position 11 on numerical columns have decimal point or #. Utilizes 2.75 wide adding machine tape and a dual color ink ribbon. Input data parallel with four bit BCD comparator circuit. Print rate 3lines per second. Operating voltage 22-28VDC with typical cycle time of 340mS. Size 6 1/2" W x 3 3/4" H x 5 1/2" Dp. New. \$8.95 ea. 3/525

78H05K	\$5.95	LM1414N	\$1.90	7400 S	.19	7475 S	.38	74161 S	.88
78L05	1.49	LM1458C/N	.99	7401	.22	7479	4.60	74183	.87
78M G	1.49	MC1489N	.99	7402	.22	7480	.49	74164	.87
LM108AH	2.95	MC1489N	.99	7403	.22	7482	.95	74165	.87
LM300H	.99	LM1496N	.89	7404	.23	7483	.55	74186	1.20
LM301CN	.35	LM1556N	1.50	7405	.35	7485	.85	74187	1.95
LM304H	1.98	LM1820N	.95	7406	.35	7487	.55	74188	1.95
LM305H	1.89	LM1850N	2.19	7407	.35	7489	1.75	74172	4.75
LM306H	3.25	LM1889N	3.10	7408	.26	7490	.39	74173	.79
LM307CN	.29	LM2111N	1.75	7409	.23	7491	.57	74174	.89
LM308CN	.98	LM2900N	.99	7410	.22	7492	.45	74175	.85
LM309K	1.49	LM2910N	2.50	7411	.29	7493	.45	74176	.75
LM309H	1.25	LM2917N	2.95	7412	.29	7494	.69	74177	.75
LM310H	.89	CA3017	2.19	7413	.38	7495	.69	74178	.75
LM312H	1.75	CA3018T	1.99	7414	.59	7495	.65	74179	1.34
LM317T	1.70	CA3021T	3.49	7415	.29	7496	.69	74180	.75
LM318CN	1.49	CA3023T	2.99	7416	.29	7497	2.90	74181	1.75
LM319H	1.25	CA3035T	2.75	7417	.22	74100	2.90	74182	.75
LM320K-XX*	1.25	CA3039T	1.95	7418	.22	74107	.32	74184	2.69
LM320T-XX*	1.25	CA3046N	.28	7419	.29	74109	.37	74185	2.25
LM323K	4.95	LM3053N	1.49	7420	.29	74116	1.95	74186	2.95
LM324N	.95	CA3059N	3.19	7421	.29	74121	.29	74188	3.90
LM327K	5.95	CA3060N	3.19	7422	.29	74122	.39	74190	1.15
LM328H	6.95	CA3062N	4.95	7423	.25	74123	.59	74191	1.15
LM329N	.95	CA3063N	1.49	7424	.25	74124	.44	74192	.85
LM340K-XX*	1.75	CA3080T	1.29	7425	.29	74126	.44	74193	.85
LM340T-XX*	1.25	CA3081N	1.69	7426	.29	74128	.59	74194	.85
LM342H	2.99	CA3082N	1.69	7427	.25	74129	.69	74195	.68
LM343H-XX*	1.55	CA3083N	1.55	7428	.29	74138	.75	74196	.85
LM348N	1.95	CA3086N	.80	7429	.29	74139	.95	74197	.85
LM350K	5.60	CA3089N	2.95	7430	.34	74160	.88	74198	1.39
LM358CN	.98	CA3096N	3.49	7441	.79	74142	2.95	74199	1.39
LM360N	1.49	CA3097N	1.99	7442	.57	74143	2.95	74221	1.19
LM372N	1.95	CA3130T	1.30	7443	.95	74144	2.95	74251	.95
LM373N	3.75	CA3140T	1.19	7444	.95	74145	.82	74273	1.05
LM377N	2.75	CA3160T	1.19	7445	.29	74159	1.35	74274	1.95
LM380C/N	1.25	CA3190N	1.95	7446	.79	74168	1.20	74275	.75
LM381N	1.79	CA3410N	.95	7447	.65	74169	1.00	74283	.40
LM383T	1.85	MC3423N	1.49	7448	.19	74152	.67	74285	3.90
LM386N	1.25	MC3450N	3.95	7451	.19	74153	.67	74290	1.25
LM389N	1.40	MC3454N	3.95	7452	.19	74154	1.19	74291	1.85
LM390N	1.95	CA3600N	3.39	7454	.19	74155	.78	74365	.68
NE531VT	3.75	LM3900N	.59	7459	.25	74156	.78	74366	.68
NE555V	.39	LM3905N	1.19	7460	.23	74157	.69	74367	.68
NE555N	.98	LM3909N	.98	7470	.29	74159	1.65	74368	.68
NE561T	1.50	LM3914N	3.75	7471	.29	74159	2.48	74369	1.45
NE565V	1.25	LM3915N	3.95	7472	.34	74160	.88	74393	1.90
NE566VH	1.75	LM3916N	3.75	7474	.34	74160	.88	74490	1.90
NE567VH	1.50	RC4131N	2.95						
NE592N	2.75	RC4136N	1.10						
LM702H	.29	RC4151N	3.70						
LM707H	1.39	CA1914T	4.95						
LM710N/H	.75	CA1915TK	5.40						
LM711N/H	.39	ULN2001	1.25						
LM715N	1.95	ULN2003	1.50						
LM723N/H	.65	SN75450N	.59						
LM733N/H	.98	SN75451N	.30						
LM739N	1.15	SN75452N	.49						
LM741CN/H	.33	SN75453N	.49						
LM741CN-14	.19	SN75454N	.49						
LM747N/H	.75	SN75491N	.89						
LM748N/H	.39	SN75492N	.89						
LM750N	2.95	SN75493N	.89						
LM7510N	1.90	SN75494N	.89						
MC1330	1.95	TL494CN	4.20						
MC1350	1.95	TL496CP	1.65						
MC1358	1.75								

RAMS

0116/2016	\$7.95	2147	\$5.99	5290	\$1.99
8264-64K	5.95	411	5.99	5298	1.49
4116-2	1.99	414	4.69	8508	4.50
4116-2	8/12-2	1101	8.99	6518	6.79
2101	3.99	1103	9.99	6561	3.79
2102	1.79	4027	4.69	6604	3.99
2102-2	1.49	4044	3.99	6605	3.99
2102-4	1.29	4050	4.69	9130	8.99
2111	3.49	4060	4.69	9140	8.99
2112	3.49	4096	3.99	93415	6.99
2114	1.99	4115	1.49	93425	6.99
2114-2	3.25	4200	7.95		
2114L-4	2.29	4402	1.99		
2125	6.99	5280	4.60		

SUPPORT

8155	\$9.95	8259	\$8.95	68047	\$22.95
8156	9.95	8275	19.95	68488	19.95
8202	29.95	8279	9.50	46505	22.95
8205	2.69	6810	4.75	6520	6.95
8212	2.75	6820	6.50	6522	9.95
8214	4.95	6821	6.50	8530-C	24.95
8216	2.75	6828	10.50	6532	17.95
8224	2.95	6834	18.95	6551	19.95
8226	2.95	6845	22.95	Z80-PIO	6.50
8228	3.95	6847	27.95	Z80-PIO	9.50
8243	9.50	6850	5.25	Z80-CTC	6.50
8250	14.95	6852	5.25	Z80A-CTC	9.50
8251	6.50	6860	10.95	Z80-DMA	19.95
8253	11.95	6862	10.95	Z80-DMA	27.95
8255	4.50	6875	5.95	Z80-SIO	24.95
8257	9.50	6880	2.49	Z80A-SIO	29.95

MOS PROMS

2784 (8Kx8) TS	\$69.95	2708 (450nS)	\$5.75
2732 (4Kx8) TS	12.95	2708 (650nS)	5.25
2716 (2Kx8) TS	7.95	1702A	5.75
27C10 (1Kx8) 1V	7.95	MM5203AQ	14.50
27C10 (1Kx8) 1.5V	7.95	MM5204Q	9.95
27E58 (5V, 450nS)	3.50		

HI-TECH

29

ADVANCED COMPUTER PRODUCTS



Vista Computer Company

Apple Computer Authorized Dealer

SIEMEN'S SALE

You can now purchase Shugart compatible 8" Disk Drives below your existing factory direct pricing!



8" Disk Drives \$199.00

These Prices are the lowest ever published!
***Siemens SSDD FDD100-8 ... \$199.00**
 Also, with purchase of Disk Drives you can buy the Vista V-1000 Dual Case with Power Supply and Cable for only \$375.00. Regular Price \$495.00
 OFFER LIMITED! FACTORY WARRANTY 90 DAYS! SHIPPED IMMEDIATELY FROM STOCK! *DEM QUANTITIES

See Special Offer on this page for additional disk saving!

HARDWARE

ABM	List	ACP
BSR-X10 Interface	595	585
Color to Mono I/O Module	95	85
Telephone Receptionist adapt	995	975
PS327/Busyn Emulator	1295	1150
AMDEK Dual 3" Amdisk		
(2) Hitachi DS (250K)	899	649
AST Megaplus Card		
P/N MG-064, 64K, Ser. Clk	595	449
P/N MG-064SP, add'l Ser. Par	695	499
P/N MG-256, 256K, Ser. Clk	695	685
P/N MG-256SP, add'l Ser. Par	1095	749
AST I/O Plus Card		
P/N I/O-SP, Clk (2) Ser. Par	265	199
AST Combo Plus Card		
P/N MC256SP, 256K, clk, P/S 995	695	695
AST PC Disk++ Card		
P/N MD-064, 64K, Host, Par	655	495
CACTUS TECHNOLOGY		
300 Baud Direct Modem	349	299
COEX		
Extender Card	40	19
Prototype Card	69	42
37 Pin "D" Connector	19	8
Snap-in Card Guides (5)	8	5
CORONA Hard Disk System		
CORVUS Hard Disk System	Call	Call
DAVONG		
5Mb Hard Disk	1995	Call
12Mb Hard Disk	2495	Call
MAYNARD Disk Drive Card		
Floppy Card w/Parallel	285	249
Floppy Card w/Serial	325	280
MAX SYSTEMS		
Mouse w/Mousepad	332	279
Mouse RS232 I/O	40	30
ORCHID		
Hi-Res Graphics Adapter	495	429
PERSYST Spectrum (64-256K)		
P/N SP64-CCP, 64K, S, S, P	499	375
64K Upgrade Kit (9 chips)	130	50
QUADRAM Quadboard (64-256K)		
P/N Q64, 64K w/4 functions	595	429
TANDON TM 100-1 (160K)	295	195
TM 100-2 (320K)	395	289
TEAC		
FD55B (320K) Disk	329	299
TG PRODUCTS		
Joystick	65	49
Track Ball	65	52
VISTA		
MULTICARD w/64K SPC	529	249
MULTICARD w/256K SPC	829	359
64K Upgrade Kit (9 chips)	50	50
"MAXICARD" w/64K	376	299
"MAXICARD" w/256K	674	549
"MAXICARD" w/576K	1176	899
"PC MASTER" 7 Functions	590	459
"DISKMAN" (15", 8")	379	299
ECONOCARD (only)	289	159

PRINTERS

COEX 80FT/80cps	\$499	\$299
STAR MICRODISC - NEW!		
Gemini 10 100cps	399	349
Gemini 15 15"	649	479
EPSON MX80 w/Graftrax	494	411
MX100 w/Graftrax	749	659
F80 w/Graftrax	699	629
INTEGRAL DATA		
Microgram 480	799	689
Prism 80 Color (all)	1795	1495
Prism 12 Color (all)	1985	1685
BROTHER HR-1	1195	895
Daisywriter	1495	1295
IBM PC to EPSON Cable	60	45
OKIDATA		
Microline 82A	499	459
Microline 83A	899	729
Microline 84AP	1399	1099
Okidata 92	699	549

MONITORS

AMDEK CORP	\$199	\$155
300 Green 12"	210	175
310 Amber 12"	339	299
Color II Composite	399	299
Color III RGB Hi-Res	899	790
Color III RGB Comm'l	1299	1059
Color IV RGB Analog	189	155
NEC 12" Green-NEW	895	799
12" RGB (690 x 230)		
PRINCETON GRAPHICS		
RGB IBM Looklike	700	599

DISKETTES

DYSAN 5 1/4" SSDD	10,355	538
DYSAN 5 1/4" SSDD	10,855	48
IBM 5 1/4" SSDD	10,665	43
IBM 5 1/4" SSDD	10,665	47
VERBATIM 525-01 SS	10,445	28
VERBATIM 525-01 DS	10,535	39
MAXELL MD1 SS	10,500	29
MAXELL MD2 DS	10,600	39
AMDEK Hitachi 3" DS Micro	599	49
BULK SPECIAL SS	10,225	19
With Sleeve and Box	100,195	149

MORE IBM GOODIES

CURTIS PC Pedestal	580	\$65
Extension Cable	50	34
INTEL 8087 IC	50	199
RAM EXPANSION		
16K Motherboard (16 IC's)	19	
64K Memory Exp (9 IC's)	39	
KRAFT IBM Joystick	70	49
IBM Paddles	50	40
MODEMS		
SIGNALMAN (Mark II RS232)	599	379
HAYES		
Smartmodem (RS232)	289	225
Smartmodem 1200	699	540
IBM PC to Modem Cable	40	30
SSM		
AMC 300 300 Baud	299	249
AMC 1200 1200 Baud	695	549
TRANSPAK I	368	349
TRANSPAK II	448	399
TRANSPAK III	569	499
NOVATION		
CAT	169	139
Per. Finance Mgr	149	119
DCAT	199	179
AUTO CAT	249	219
2V2 AUTO CAT	695	595

S-100 64K "CMOS" RAMCARD



Unbelievable Price!
\$269.00
 Assembled and Tested

□ ACP has sold over 1000 of these IEEE compatible, low-priced, high-reliability 64K Static RAM Cards.
 □ Single 5-Volt operation.

LPS II

Light Pen System for Apple II Computers
ACP \$299.00
 Price \$299.00

COEX 80-FT



Best of all, the price...
\$299.00
 only

Optional COEX Interface Card to Apple... \$49.95
Apple System Saver Fan
 Surge Suppressor Fan. Double Outlet Receptacle... \$79.95

IBM LOW COST MEMORY

MEMORY PLUS AT LOW PRICES!
 Now "Multicard" expandable from 64 - 256K with
 (1) PARALLEL (1) SERIAL (1) CLOCK/CALENDAR
COEX 255 SPC with 64K \$229.00
COEX 64 SPC with 256K \$335.00

FLOPPY DISK DRIVES SINGLE-SIDED 8"

MFG	P/N	1	2	10	MFG	P/N	1	2	10
Shugart	S4801R	\$385	\$379	\$369	Tandon	848-1	\$369	\$362	\$353
Siemens	FDD100-8	199	196	Call					
Shugart	S4851R	519	495	469	Siemens	FDD200-8	399	389	379
Qume	Dataltrack 8	515	490	465	Tandon	848-2	479	475	469
Shugart	860 Thin	559	539	519					
Shugart	S4400	210	208	198	Tandon	TM100-1	205	198	185
MPi	551	210	208	198	Pentec	FD200	189	188	185
Shugart	S4850	345	325	313	Tandon	TM100-2	289	285	259
Pentec	FD250	159	159	149					
TEAC	5 1/4" Thinline	375	365	359	Qume	5 1/4" Thinline	375	365	359
Hitachi	Call	Call	Call	Call					
Seagate	ST508(BMB)	699	679	599	Seagate	ST512(12Mb)	890	875	949
IMI	5006(GMB)	885	850	819	IMI	S012(12Mb)	1088	1070	1020
IMI	S018(18Mb)	1313	1299	1225					

SPECIAL LIQUIDATION - SMALL QTY
SHUGART 4004
 14" WINCHESTER
 Only 10 Available - So Hurry!
 14.5 MEGABYTES
 List 2495.00
Special Sale Price ... \$995.00



"SOLO" Apple II/IIe Compatible Disk Drive

Totally compatible to Apple Drives.
\$249.00
 only
 Controller \$99.00
 Just plug in and run.



Vista Quartet

Equivalent to 4 Apple Drives
 only ...
\$799.00
 Add 8" Disk Drives To Your Apple II/IIe
 Up To 2.4 Megabyte!
 Now "TRIMLINE V1100" with Tandon Thinline DS DD Drives.
 Tandon Dual DS DD \$1895.00
 Qume Dual DS DD \$1699.00
 Shugart Dual 801R \$1295.00



SPECIAL OFFER
 (2) Siemen's 8" Disk Drives (1) Vista V-1000 Enclosure (1) Power Supply w/Fan, w/Cable
ACP Low Price \$699.00
 Apple Compatible Software

SAVE UP TO 40%

BUSINESS	HOBBY
Screen Writer \$129	Bag of Trunks \$32
Word Hancer 149	Graphics Magic n 45
BD Master 155	DOS Boss 19
Visicalc™ 3.3 185	Zoom Graphics 32
Master Type 29	Unity City 22
Desk Top Plan II 179	Locksmith 4.0 90
Desk Top Plan III 225	Compl Graph Sys 55
Visplot 119	Apple Mechanic 24
PFS, File II 115	Nibbles Away II 19
PFS, File III 155	GAMES 25
Visitrend/Visplot 25	The Missing Ring 29
PFS, Graph II 115	N15 Choptier 19
PFS, Graph III 155	Frogger 24
Multiplan 199	Wizardy 24
Versalcom 279	Snack Attack 24
Wordstar 365	Castle Wolfenstein 24
Format II 179	Arcade Machine 44
dBASE II 439	Canyon Climber 24
Supercalc 169	Aztec 29
PFS, Report II 95	Mask of the Sun 29
PFS, Report III 115	Canonball Blitz 26
ACLI Plus G.L. 299	Knight Diamonds 26
G.L. A.P. A.R. 599	Zork I 29
Above - Inventory 799	Zork II 29
Magic Window 115	Siarcross 29
Home 365	Serpentine 25
Home Accountant 59	Siar Blazer 39
Trans II 76	Deadline 39
Data Capture 4.0 49	Tubeway 25
Vistalim 89	Fight Simulator 29
Per. Finance Mgr 85	Space Vikings 49
ASCI Express Prof. 99	Splinter Simulator 29
Electronic Dvnt 25	Apple Panic 22
Tax Prep. 1983 149	Olympic Death 23

Apple IIe w/64K	LIST \$1395.00	ACP \$1195.00
Apple IIe System	1995.00	1695.00
Apple IIe Sys w/Ext Tank	2195.00	1895.00
Disk II w/Controller	545.00	449.00
Disk II w/ Controller	395.00	359.00
Monitor III Green	249.00	189.00
Super Serial Card	195.00	169.00
Parallel Interface Card	165.00	139.00
80 Column Text Card	125.00	109.00
Extended 80 Column Text	295.00	249.00
Dot Matrix Printer	695.00	529.00

MORE HARDWARE

MICROSOFT	LIST	ACP
Z80 Softcard	\$395.00	\$249.00
16K Ramcard	195.00	89.00
The Premium Package	685.00	654.00
SSM		
AIO-II 4 Function Serial/Parallel	225.00	179.00
AIO Serial/Parallel	195.00	165.00
EASTAR		
Wildcard Apple II	149.00	115.00
KENSINGTON		
System Saver	89.95	74.95
KEYBOARD COMPANY		
Numeric Keypad	149.95	124.95
Apple II Joystick	49.95	44.50
Apple II Handcontrollers	29.95	25.95
KRAFT (IBM also)		
Joystick	49.00	49.00
Hand Controller		
MPC		
128K Bubble Memory	875.00	699.00
PROMETHEUS		
VERSABOX Spool/Bufrr	249.00	199.00
VERSAROC Four-in-1	199.00	168.00
AUTO-DOC diagnostics	99.00	82.00
VISTA COMPUTER CO.		
Vision II 80/24 Card	395.00	219.00
Vision 80 Visicac 80		
Col Patch	69.00	49.00
ABO8 8" Disk Contr	379.95	348.00
Quarte Disk Drive 5 1/4"	849.00	799.00
Solo Disk Drive w/Contr	299.00	249.00
Solo Drive w/o Contr	379.00	319.00
Vista 5 1/4" Disk Contr	92.00	79.00
Typeahead Buffer	49.95	35.00
VIDEX		
Videoترم 80x24 Card	345.00	279.00
Keyboard Enhancer II	149.00	129.00
Soft Switch	35.00	30.00
Function Strip Keys	79.00	68.00
PRACTICAL PERIPHERALS		
16K Microbuffer	259.00	220.00
32K Microbuffer	299.00	253.00
Snapshot Option	149.00	109.00
VOTRAX		
Type n Talk Speech	249.00	219.00
Personal System	395.00	339.00
VYNET		
Apple II Voice Syn	395.00	349.00
Vision II Telephone I/O	295.00	

MICROPROCESSOR COMPONENTS

Table listing microprocessor chips with columns for Part No., Price, and Pin Price. Includes models like 741500, 741501, 741502, etc.

Table listing microprocessor chips with columns for Part No., Price, and Pin Price. Includes models like 741592, 741593, 741594, etc.

Table listing microprocessor chips with columns for Part No., Price, and Pin Price. Includes models like 741596, 741597, 741598, etc.

Digitaltek™ DT1050 - Applications: Teaching aids, appliances, clocks, automotive, telecommunications, language translations, etc.

DT1057 - Expands the DT1050 vocabulary from 137 to over 260 words. Incl. 2 ROMs and specs.

DT1050 Digitaltek™ \$34.95 ea.

DT1057 \$24.95 ea.

Table listing Intersil ICs with columns for Part No., Price, and Pin Price. Includes models like 740451, 740452, 740453, etc.

Table listing 74LS series ICs with columns for Part No., Price, and Pin Price. Includes models like 74LS01, 74LS02, 74LS03, etc.

Table listing 74LS series ICs with columns for Part No., Price, and Pin Price. Includes models like 74LS192, 74LS193, 74LS194, etc.

Table listing 74LS series ICs with columns for Part No., Price, and Pin Price. Includes models like 74LS221, 74LS222, 74LS223, etc.

30009 1983 Intersil Data Book (1356p.) ... \$9.95!

NEW PRODUCTS 74HC High Speed CMOS

Table listing 74HC series ICs with columns for Part No., Price, and Pin Price. Includes models like 74HC00, 74HC01, 74HC02, etc.

Programmable Array Logic (PALs)

Table listing PALs with columns for Part No., Price, and Pin Price. Includes models like PAL10H, PAL12H, PAL14H, etc.

30012 1982 National PAL Data Book (176p.) ... \$5.95

Table listing 74S/PROMS series ICs with columns for Part No., Price, and Pin Price. Includes models like 74S00, 74S01, 74S02, etc.

Table listing 74S/PROMS series ICs with columns for Part No., Price, and Pin Price. Includes models like 74S243, 74S244, 74S245, etc.

Table listing 74S/PROMS series ICs with columns for Part No., Price, and Pin Price. Includes models like 74S247, 74S248, 74S249, etc.

Table listing CA-LINEAR series ICs with columns for Part No., Price, and Pin Price. Includes models like CA3010H, CA3013H, CA3015H, etc.

Table listing CD-CMOS series ICs with columns for Part No., Price, and Pin Price. Includes models like CD4001, CD4002, CD4003, etc.

Table listing LOW PROFILE (TIN) SOCKETS with columns for Part No., Price, and Pin Price. Includes models like 8 pin LP, 16 pin LP, etc.

Table listing 74C-C/MOS series ICs with columns for Part No., Price, and Pin Price. Includes models like 74C00, 74C01, 74C02, etc.

Table listing LINEAR series ICs with columns for Part No., Price, and Pin Price. Includes models like LM709, LM710, LM711, etc.

MasterCard ameco ELECTRONICS VISA 1355 SHOREWAY ROAD, BELMONT, CA 94002 8163 PHONE ORDERS WELCOME - (415) 592-8097 Telex: 176043

TIMEX Sinclair 1000

• Powerful - fully programmable 2K memory • Portable - 6" x 6" x 1 1/2" - 12 oz. • Expandable - Optional 16K RAM module • Single-key entry commands • Educational - Unique syntax-check report codes for error identify • Accurate to 9% decimal places for full range math and scientific functions • Graph drawing and animated display • Advanced 4-chip design combining power, portability and affordable price.



TS1000 \$54.95

ACCESSORIES FOR TIMEX Sinclair 1000 and ZX81

TIMEX Sinclair 1016 Expansion from 2K to 16K, size: 3" x 3" x 1.5" (5 oz) TS1016 \$49.95
 32 column (thermal printer) (14 lbs) TS2040 \$99.95
TIMEX Sinclair 2040 Printer paper - 3 rolls (4.3 in. x 6.2 in.) TTP-3 \$5.95

Keyboard Mask for Your ZX81/1000* Computer

JE681 KEYBOARD MASK \$9.95 each

The JE681 Keyboard Mask provides users of the ZX81/1000 series computer the individual feel of each keypad on the keyboard. The mask has a rubber outline around each keypad allowing the user to feel and correctly position their fingers onto the keypads.

ZX81/1000* Keyboard Conversion Kit

JE682-AK Keyboard Conversion Kit \$99.95 ea. (WITH DIE IN CASE - AS PICTURED)
JE682 Keyboard Conversion Kit (WITHOUT DIE IN CASE) \$59.95 ea.

The JE682 kit provides users of the ZX81/1000 series computers a full size 80-key keyboard to use with their computer. The JE682 kit allows the use of either the full size keyboard or the Sinclair/Times Keyboard. The kit also permits the simple disconnection of the Sinclair/Times Keyboard for portable use. The JE682 kit consists of a full size industrial grade keyboard with 80 keys, 2 pc. boards, 24 ribbon cable, DSI adapter and 4 rubber feet. The keyboard conversion kit can easily be mounted into the DIE IN CASE enclosure. This enclosure is large enough to contain the ZX81/1000 computer and the full size keyboard together. A handy label representing the ZX81/1000 keyboard layout is placed on the enclosure.

80-Key Keyboard

CA150C \$69.95

These Control Data Keyboards consist of a base, cover, the keyboard assembly, and an interface cable. Color (case): Harvest gold and black. Color (keycaps): Black, blue, and red. Electrical requirements: +5V @ 500mA, +12V @ 50mA. Size: 21 1/2" W x 9" D x 3 1/2" H. Weight: 5 lbs. All units brand new in original boxes, specifications included.

CONTROL DATA KEYBOARDS

- ★ 7-bit Parallel ASCII
- ★ SPST Switching
- ★ FTZ Shielded Base
- ★ N-Key Rollover
- ★ 128 Character ASCII
- ★ Non-Slip, Non-Glare Keycaps
- ★ CDC752 Terminal Keyboards
- ★ Attractive Case

95-Key Keyboard

CA154A \$79.95

Made for Visual Technology, this keyboard features a security keypad (includes two keys) to guard against unauthorized use, an 11-key numeric keypad, cursor controls, and 10 user-programmable keys. Electrical requirements: +5VDC. Color (case): White. Color (keycaps): Black. Complete with case, keyboard assembly, 40-inch interface cable, and schematics. Weight: 7 lbs.

Keytronics 90-Key Soft-Programmable Keyboard

Part No. KB270 \$79.95 each

• RFI shielded
 • Cursor controls
 • Numeric keyboard
 • 8-bit Parallel
 • Capacitance keys
 • 10 user-programmable keys
 • Positive TTL Logic
 • Size: 17" L x 8 1/2" W x 2 1/4" H

Micro-Logic Corp. MICRO-CHARTS

PART NO.	REFERENCE	PRICE
ML-280	Z80 CPU	\$5.95
ML-8080A	8080A/8085A	\$5.95
ML-6502	6502 (65X4)	\$5.95
ML-8048	8048, Relatives, Algorithms	\$5.95
ML-7400	5400/7400 TTL	\$5.95

BOOKS

30001	National CMOS Data Book (1981) (640 pages) 74C, CD4000, and A/D Converters	\$6.95
30003	National Linear Data Book (1982) (1376 pages) LM, LF, ADC, DAC, LH Series	\$11.95
30006	National Memory Data Book (1980) (464 pages) RAMs, ROMs, PROMs, EPROMs Series	\$6.95
30009	Intel® Data Book (1983) (1356 pages) Complete Line	\$8.95
30010	National Audio/Radio Handbook (1980) (240 pages) Pre-Amps, AM, FM & FM Stereo, Power Amps	\$5.95
30011	National Linear Application Handbook (1980) (736 pages) Application Notes, Linear Briefs, etc.	\$15.95
30012	National PAL Data Book (1982) (178 pages) Application Notes, Linear Briefs, etc.	\$5.95
30013	Zilog Data Book (1983) (641 pages) Microprocessors and Support Chips	\$7.95
210830	Intel Memory Components Handbook (1983) (796 pages) Contains all Application Notes, Article Reprints, Data Sheets, and other design information on Intel's RAMs, EPROMs, EPROMs & Bubble Memories	\$14.95
210844	Intel Microprocessor & Peripheral Handbook (1983) (1027 pages) Contains Data Sheets on all of Intel's Microprocessors and Peripherals	\$34.95

ATARI

ATARI PADDLES	JSP (2) \$4.95 pair
ATARI DRIVER	JSD (1) \$2.95 ea.
TV GAME SWITCH	Used on Atari. Cosmetically blemished. 100% functional.
TGS-1 \$2.95 ea.
Digital Thermometer Kit	JE300 \$39.95
Computer Keyboard Enclosures	Universal \$24.95
	DE-8 Panel Width 7.5" \$24.95
	DE-11 Panel Width 10.13" \$27.95
	DE-14 Panel Width 13.5" \$29.95
	DE-20 Panel Width 19.25" \$34.95

2708, 2716, 2732 & 2764 EPROM Programmer

JE664 EPROM PROGRAMMER
 8K TO 64K EPROMS - 24 AND 28 PIN PACKAGES
 — PROGRAMS 2716's IN 16 SECONDS —
 — PROGRAMS 2764's IN 64 SECONDS —

• Programs, validates, and checks for properly erased EPROMs • Emulates EPROMs • JE664's RS232C Computer Interface for adding/program loading • Loads data into RAM by keyboard • Changes data in RAM by keyboard • Loads RAM from an EPROM • Compares EPROMs for content differences • Copies EPROMs • Power input: 115VAC, 50Hz, 10W power consumption • Enclosure: Color-coordinated, plastic case panels w/industrial mocha brown end pieces • Size: 15.5" x 7.1" x 4.0" x 3 1/2" H. Wt.: 5 1/2 lbs.

JE664-A EPROM Programmer \$995.00
 Assembled & Tested (Includes JM16A Module)

JE665 — RS232C INTERFACE OPTION — The JE665 RS232C Interface Option eliminates computer access to the JE664's RAM. Sample software written in BASIC provided for TRS-80 Model I, Level II Computer, Busd rate: 9600. Word Length: 8 bits - odd parity. Stop bits: 2. Option may be adapted to other computers.

JE664-ARS EPROM Prog. w/ JE665 Option \$1195.00
 Assembled & Tested (Includes JM16A Module)

EPROM JUMPER MODULES

The JE664 JUMPER MODULE (Personality Module) is a plug-in module that re-writes JE664 for proper programming pulses to the EPROM & configures EPROM socket connections for that particular EPROM.

Part No.	EPROM	EPROM MANUFACTURER	PRICE
JM06A	2708	AMD, Motorola, National, Intel, TI	\$14.95
JM16A	2716, 1M52516	Intel, Motorola, National, NEC, TI	\$14.95
JM16B	1M52716	Motorola, TI (+5, -12, -12)	\$14.95
JM32A	1M52532	Motorola, TI	\$14.95
JM32B	2732	AMD, Fujitsu, NEC, Hitachi, Intel	\$14.95
JM32C	2732A(21V)	Fujitsu, Intel	\$14.95
JM64A	MC68B764	Motorola	\$14.95
JM64B	2764	Intel	\$14.95
JM64C	1M52564	TI	\$14.95
JM64D	HN482764G-4	Hitachi (21V)	\$14.95

iii's Black Hole EPROM Eraser

9 Chips — 8 Minutes

The Black Hole EPROM Eraser will completely and safely erase 9 EPROMs in less than 8 minutes. The Black Hole is a fully automatic cassette loading eraser featuring U-shaped 4000 hr. UV lamps mounted in a special ALZAK (UV reflectivity of 9) parabolic light tunnel. In operation, the user slips in an anti-static Bug Box (3 ea. incl.) containing the EPROMs to be erased into the loading slot on the front panel of Black Hole. The rest is fully automatic. The Black Hole latches the Bug Box into place, turns on the UV lamps and starts its fully solid state (CMOS) UV integration dose timer. The percentage erasure time is monitored and displayed on a front panel LED readout. At the end of the erase cycle, the Black Hole ejects the Bug Box containing the 9 erased EPROMs and turns off power.

PART NO.	PRICE
ULV-008	Replacement Lamp for ERS-008 \$29.95
ERS-008	Eraser, Auto Eject & LED Readout \$249.95

IBM MEMORY EXPANSION KIT

SAVE HUNDREDS OF \$\$\$ BY UPGRADING MEMORY BOARDS YOURSELF!

Most of the popular memory boards allow you to add an additional 64K, 128K, 192K, or 256K. The IBM64K Kit will populate these boards in 64K byte increments. The kit is simple to install — just insert the nine 64K RAM chips in the provided sockets and set the two groups of switches. Directions are included.

IBM64K (Nine 200ns 64K RAMs) \$59.95

EXPAND YOUR MEMORY

TRS-80 to 16K, 32K, or 48K

Model 1 = From 4K to 16K Requires (1) One Kit
 Model 3 = From 4K to 48K Requires (3) Three Kits
 Color = From 4K to 16K Requires (1) One Kit

*Model 1 equipped with Expansion Board up to 48K Two Kits Required — One Kit Required for each 16K of Expansion

TRS-16K3	*200ns for Color & Model III	\$12.95
TRS-16K4	*250ns for Model I	\$10.95

TRS-80 Color 32K or 64K Conversion Kit

Easy to install kit comes complete with 8 ea. 4164-2 (200ns) 64K Single RAMs & conversion board. Converts TRS-80 color computers with E circuit boards, & all new color computers to 32K. Minor modifications of 32K memory will allow the use of all the 64K of the dynamic RAM providing you have a FLEX DOS operating system.

TRS-64K2 \$54.95

5 1/4" Mini-Floppy Disk Drive

FOR TRS-80 MODEL I. COLOR COMPUTER

Features single or double density, recording mode, FM single, MFM double density. Seek time, format, track to track, power, +12VDC (±0.6V) 1.6A max. +5VDC (±0.25V) 0.8A max. Unit as PIC at right end not incl. case, power supply, cables, 30 pp. data book incl. 3/16" slot. Size: 5 1/4" x 8" x 3 1/4" H.

Part No.	Limited Quantity	Price
FD200	50	\$179.95
FD250	50	\$199.95

Double-sided, 35 tracks, 438K bytes capacity

8" FLOPPY DISK DRIVE

The FDD100-8 8" Floppy Disk Drive (Industry Standard) features single or double density. Recording mode: FM single, MFM double density. Transfer rate: 250K B/track, single density; 500K B/track, double density. The FDD100-8 is designed to work with the single-sided soft sector IBM Diskette I, or, disk cartridge. Power: 115VAC ±0.50Hz, ±24VDC @ 1.7 amps max. +5VDC @ 1.2 amps max. Unit as picture shown does not include case, power supply, or cables. Size: 8.55" W x 14" L x 4.5" H. Weights: 12 lbs. incl. 96-pp. manual.

Part No.	Price
FDD100-8	\$169.95 ea.

\$10.00 Minimum Order — U.S. Funds Only
 California Residents Add 6% Sales Tax
 Shipping — Add 5% plus \$1.50 Insurance
 Send S.A.S.E. for Monthly Sales Flyer!

Spec Sheets — 30c each
 Send \$1.00 Postage for your
 FREE 1983 JAMECO CATALOG
 Prices Subject to Change

MasterCard JAMECO ELECTRONICS VISA®
 1355 SHOREWAY ROAD, BELMONT, CA 94002
 8183 PHONE ORDERS WELCOME — (415) 592-8097 Telex: 176043

NOT JUST AN ORDINARY SALE! WE HAVE **SLASHED PRICES TO THE BONE** AS OUR WAY OF THANKING YOU, OUR VALUED CUSTOMERS FOR 6 YEARS OF LOYALTY. WE'VE CONTINUOUSLY GROWN AND EXPANDED BY OFFERING YOU THE BEST VALUE FOR YOUR MONEY WITH THE BEST AFTER-SALE SUPPORT

AT LAST! CP/M 68K!!!

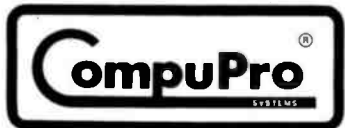

CPU BOARDS

68K - 68000 16 BIT CPU

16 bit 8 or 10 MHz on-board sockets for 2716, 2732, or 2764 EPROMs for up to 8K x 16 of memory

Part No.	Description	List Price	Our Price
BTGBT104A	A&T 8MHz	\$695.00	\$512.95
BTGBT104C	CSC 10MHz	\$850.00	\$705.00

CP/M® 68K NOW AVAILABLE!!!

Now CompuPro and Digital Research bring you CP/M for the 68000!!

BTGBTCPMB8K	68000 CP/M®		\$350.00
-------------	-------------	--	-----------------

FORTH OPERATING SYSTEM FOR 68K CPU

Requires a DISK 1, 64K of CompuPro memory, and an INTERFACER 3 or 4

BTGBTBK08S	FORTH operating system		\$200.00
------------	------------------------	--	-----------------

CO-PROCESSOR 8086/8087

16 bit 8 or 10 MHz 8086 CPU with sockets for 8087 and 80136

BTGBT106A	A&T 8MHz 8086 only	\$ 750.00	\$494.95
BTGBT106C	CSC 10MHz 8086 only	\$ 850.00	\$764.89
BTGBT106A&T	A&T with 8087 option	\$1050.00	\$939.00
BTGBT106C&T	CSC with 8087 option*	\$1150.00	\$1065.00

*8087 Limits clock speed to 5MHz

DUAL PROCESSOR 8085-8088

6 or 8 MHz provides true 16 Bit Power with a standard 8 bit S-100 bus.

BTGBT1012A	A&T 6MHz	\$495.00	\$318.97
BTGBT1012C	CSC 6/8 MHz	\$595.00	\$487.87

CPUZ - Z80B CPU NOW 6MHz!

3/6 MHz Z80B CPU with 24 Bit Addressing. FASTEST Z80 CPU AVAILABLE!

BTGBT106A	3/6 MHz A&T	\$325.00	\$228.95
BTGBT106C	3/6 MHz CSC	\$425.00	\$374.87

DISK CONTROLLERS

DISK 1 DMA FLOPPY CONTROLLER

Fast DMA. Soft Sector. Controls Up to Four 8" or 5 1/4" Single or Double Density Drives!

BSPOB171ACPM	A&T w/CPM 2.2" & BIOS	\$670.00	\$489.00
	When purchased w/two 8" disk drives only		\$450.00
BTGBT171CCPM	CSC w/CPM 2.2" & BIOS	\$770.00	\$595.00
BTGBT171A	Disk 1 Controller A&T	\$495.00	\$368.95
BTGBT171C	Disk 1 Controller CSC	\$595.00	\$550.00
BTGBTCPMB0	CP/M 2.2" for Z80/8085 w/manual & BIOS 8" S/D disk	\$148.95	\$148.95
BTGBTCPMB8	CP/M 2.2" for 8086 w/manuals & BIOS 8" S/D disk	\$258.95	\$258.95

DISK 2/SELECTOR CHANNEL

HARD DISK CONTROLLER

Fast DMA 2 board set controls 4 Shugart 4000 series or Fujitsu 2300 type drives. Includes CP/M 2.2".

BTGBT177A	Assembled & Tested	\$795.00	\$568.95
BTGBT177C	CSC	\$895.00	\$850.00

M-DRIVE/H HARDWARE LOGICAL DISK SYSTEM

Interfaces through two I/O ports, and runs at 10MHz IEEE 696 compatible. Requires any CompuPro CPU and a DISK 1. Each board contains 512K of fast, low power (900mA) RAM, with parity checking.

BTGBT107A	M-DRIVE/H w/software, A&T	\$1895.00	\$1249.95
BTGBT107C	M-DRIVE/H w/software, CSC	\$2095.00	\$1495.00

STATIC RAM

RAM 17 - 64K CMOS STATIC RAM

12 MHz. RAM 17, 2 Watt. DMA Compatible 24 Bit Addressing

BTGBT175A&T	64K A&T 12MHz	\$499.00	\$460.00
BTGBT175C&T	64K CSC 12MHz	\$599.00	\$550.00

RAM 16 - 32K x 16 BIT CMOS STATIC RAM

8 and/or 16 Bit 12MHz. RAM 16, 32K x 16 or 64K x 8 IEEE/696 16 Bit 2 Watt. 24 Bit Addressing

BTGBT180A	64K A&T 12MHz	\$550.00	\$510.00
BTGBT180C	64K CSC 12MHz	\$650.00	\$610.00

RAM 24 - 128K STATIC RAM

816 RAM 21 12MHz, 128K x 8 or 64K x 16 IEEE/696 8 or 16 Bit. 1.2 Amps, 24 Bit Addressing

BTGBT190A	128K A&T	\$1095.00	\$858.95
BTGBT190C	128K CSC	\$1245.00	\$1125.00



I/O BOARDS

SYSTEM SUPPORT 1 MULTIFUNCTION BOARD

Serial port (software prog. baud), 4K RAM included, 15 levels of interrupt, real time clock, optional math processor.

Part No.	Description	List Price	Our Price
BTGBT102A	Assembled & Tested	\$450.00	\$308.95
BTGBT102C	CSC	\$550.00	\$405.00
BTGBT231	Math Chip		\$195.00
BTGBT232	Math Chip		\$195.00
BTGBT102A&T	A&T w/8231 Math Chip	\$645.00	\$538.95
BTGBT102C&T	CSC w/8231 Math Chip	\$745.00	\$670.00
BTGBT102A&T	A&T w/8232 Math Chip	\$645.00	\$538.95
BTGBT102C&T	CSC w/8232 Math Chip	\$745.00	\$670.89

MPX CHANNEL BOARDS

I/O Multiplexer, using 8085A-2 CPU on board w/16K RAM

BTGBT106A10	Assembled & Tested	\$649.00	\$584.89
BTGBT106C10	CSC	\$749.00	\$674.89

INTERFACER 1

Two Serial I/O

BTGBT133A	Assembled & Tested	\$295.00	\$198.95
BTGBT133C	CSC	\$370.00	\$329.00

INTERFACER 2

Three parallel, one serial I/O board

BTGBT150A	Assembled & Tested	\$325.00	\$249.00
BTGBT150C	CSC	\$399.00	\$359.00

INTERFACER 3

Eight-channel multi-user serial I/O board

BTGBT1748A	Assembled & Tested	\$699.00	\$448.95
BTGBT1748C	CSC 200 hr. 8 port	\$849.00	\$748.95
BTGBT1745A	Assembled & Tested	\$599.00	\$518.95
BTGBT1745C	CSC 200 hr. 5 port	\$699.00	\$628.89

INTERFACER 4

Three Serial, 1 Parallel, 1 Centronics Parallel

BTGBT107A	Assembled & Tested	\$450.00	\$314.87
BTGBT107C	CSC	\$540.00	\$414.87

S-100 MOTHERBOARDS

Active Termination, 6-12-20 Slot

BTGBT153A	A&T 6 slot (2 lbs.)	\$140.00	\$125.00
BTGBT153C	CSC 6 slot (2 lbs.)	\$190.00	\$155.00
BTGBT154A	A&T 12 slot (3 lbs.)	\$175.00	\$155.00
BTGBT154C	CSC 12 slot (3 lbs.)	\$240.00	\$220.00
BTGBT155A	A&T 20 slot (4 lbs.)	\$265.00	\$235.00
BTGBT155C	CSC 20 slot (4 lbs.)	\$340.00	\$310.00



California Computer Systems

Z80 CPU 2 or 4MHz

On board RS232 Serial port, On board 2K Monitor, ROM, Power on jump to any location in 64K. LED status indicators for ROM select, halts and Interrupts.

BTCCS2810A	Z80A 4MHz CPU A&T	\$325.00	\$258.95
------------	-------------------	----------	-----------------

CCS271901

BTCCS271901	2 Serial, 2 Parallel, A&T	\$360.00	\$288.95
-------------	---------------------------	----------	-----------------

CCS27201

BTCCS272001	4 Port Parallel, A&T	\$275.00	\$218.95
-------------	----------------------	----------	-----------------

CCS271001

BTCCS271001	4 Port Serial, A&T	\$325.00	\$278.95
-------------	--------------------	----------	-----------------

CCS2830

BTCCS283001	Assembled & Tested	\$550.00	\$428.95
-------------	--------------------	----------	-----------------

CCS206601

BTCCS206601	Assembled & Tested	\$450.00	\$425.00
-------------	--------------------	----------	-----------------

CCS2422A

BTCCS2422A	Assembled & Tested	\$475.00	\$338.95
------------	--------------------	----------	-----------------

Circle 322 on inquiry card.



IOS

2 Serial, 3 Parallel S-100 Interface

Part No.	Description	List Price	Our Price
BTSSM105A	Assembled & Tested	\$329.00	\$288.89

IO8

8 Port Serial I/O S-100 Board

BTSSM108A	Assembled & Tested	\$550.00	\$450.00
-----------	--------------------	----------	-----------------

IO4

2 Serial, 2 Parallel I/O S-100 Board

BTSSM104A	Assembled & Tested	\$290.00	\$245.00
-----------	--------------------	----------	-----------------

2708/2716 EPROM PROGRAMMER & EPROM BOARD

Programs 2708 and 2716 EPROMs. Holds 4 2708s (4K) or 4 2716s (8K)

BTSSM08A	Assembled & Tested	\$265.00	\$218.87
----------	--------------------	----------	-----------------



NON VOLATILE CMOS RAMS

8, 16, or 32K 8 or 16 Bit Data. Battery Backup On Board 6MHz. Bank Selectable

BTDULCMEM8	8K A&T	\$495.00	\$450.00
BTDULCMEM16	16K A&T	\$595.00	\$550.00
BTDULCMEM32	32K A&T	\$695.00	\$650.00

256K DYNAMIC MEMORY

256K. 230 ns access time. 2 x 128K organization. 24 bit addressing, parity error detection.

BTDULDMEM256K	Assembled & Tested	\$1295.00	\$1195.00
---------------	--------------------	-----------	------------------

32/64K EPROM BOARD

8 or 16 bit data, holds 2716s (32K), or 2732s (64K)

BTDULEPROM32	For 2716s A&T	\$295.00	\$275.00
BTDULEPROM64	For 2732s A&T	\$295.00	\$275.00

A/D CONVERTER

12 Bit Resolution 16 or 32 Channel Input

BTDLAIM12B	Assembled & Tested	\$695.00	\$625.00
BTDLAIM12B	Without instru. Amp	\$645.00	\$588.00

D/A CONVERTER

4 Channel, 12 Bit, 3 Output Modes

BTDLAOM12	Assembled & Tested	\$695.00	\$618.95
-----------	--------------------	----------	-----------------



SIERRA DATA SCIENCES

S-100 SDC BOARD

Z80A 4MHz, 2 Serial RS232 Interfaces, 1 parallel interface, 64K RAM.

Floppy Disk Controller, provisions for one 2732 EPROM —

ALL ON THIS ONE BOARD!!

BTSDSSBC	Z80A SBC A&T	\$895.00	\$855.00
BTSDSCPM	CP/M® Operating System on 8" disk		\$150.00
BTSDSTURB03	Single User TurboDos™ on 8" disk		\$450.00
BTSDSTURB0M	Multi-User TurboDos™ on 8" disk		\$750.00
BTMCP12231	36 MByte Hard Disk (45 lbs.)	\$3695.00	\$3250.00

S-100 Z80A SLAVE SDC

Z80A 4MHz, 2 RS232 Serial ports, 4 parallel ports, 64K RAM, EPROM Programmer. Used In multi-user computer system with SDDSBC.

BTSDSSBCSE	Slave Z80 SBC A&T	\$825.00	\$565.00
------------	-------------------	----------	-----------------



Intercontinental Micro Systems

Z80A DMA SDC & Z80B SLAVES

S-100 IEEE/696 COMPATIBLE - 1 YEAR WARRANTY!

CPZ-48000 FEATURES: SLAVE PROCESSOR

- 4MHz Z80A, 64K RAM
- Floppy disk personality card included for 5 1/4" or 8"
- RS232 personality card included
- Two serial - two parallel I/Os
- Z80 4 or 6MHz CPU (specify at time of order)
- Two serial - two parallel I/Os
- 64K RAM
- TURBODDS compatible

Part Number	Description	List Price	SALE PRICE
BTICMCPZ48000S	SBC for 8" floppy	\$995.00	\$895.00
BTICMCPZ48000S	SBC for 5 1/4" floppy	\$995.00	\$895.00
BTICM256KMB	256 KByte RAM	\$995.00	\$895.00
BTICMCP5A	Z80A Slave 4MHz	\$475.00	\$440.00
BTICMCP5B	Z80		

PRIORITY ONE IS NUMBER 1!

OTHERS COME AND GO, WHILE WE HAVE BECOME THE LARGEST MAIL-ORDER DISTRIBUTOR IN THE MICRO-COMPUTER INDUSTRY. ORDER WITH CONFIDENCE. WHEN YOU HAVE A QUESTION, WE'LL BE HERE NEXT WEEK, NEXT MONTH AND NEXT YEAR! WE'RE NUMBER 1 AND STILL TRYING HARDER!

S-100 MAINFRAMES

PARADYNAMICS

BTDPN2010D	18 slot desk top (45 lbs.)	\$860.00
BTDPN2018R	18 slot rack mount (45 lbs.)	\$895.00
BTDPN2010S	18 slot w/power-seq, floor standing (Shipped freight collect)	\$1195.00
BTDPN2010	Same as above w/no power up seq. (Shipped freight collect)	\$1150.00

SIERRA DATA SCIENCES

BT30SMF	12 slot mainframe (30 lbs.)	\$595.00
BT30SWMCP0	Same as above w/no power up seq. (Shipped Freight Collect)	\$595.00

Q.T. COMPUTER

BTQTCMF	Mainframe / no motherboard (45 lbs.)	\$305.00
BTQTCMF12	12 slot mainframe (45 lbs.)	\$489.00
BTQTCMF10	18 slot mainframe (45 lbs.)	\$499.00
BTQTCMF22	22 Slot mainframe (45 lbs.)	\$530.00
BTQTCMFMD	No motherboard cutouts for two 5 1/4" drives (45 lbs.)	\$345.00
BTQTCMFMD6	6 slot, two 5 1/4" cutouts (45 lbs.)	\$530.00
BTQTCMFMD12	12 slot, two 5 1/4" cutouts (45 lbs.)	\$560.00
BTQTCMFDD6	6 slot, two 8" cutouts (48 lbs.)	\$530.00
BTQTCMFDD8	8 slot, two 8" cutouts (48 lbs.)	\$595.00
BTQTCMFDD12	12 slot, two 8" cutouts (48 lbs.)	\$625.00

COMPUPRO

BTGBTEC200K	20 slot desk top (Sh. Freight Collect)	\$695.00
BTGBTEC20RM	20 slot desk top (Sh. Freight Collect)	\$795.00

DUAL QUME 8" FLOPPY DRIVE, CABINET, DMA S-100 CONTROLLER, AND CP/M®

\$1595.00

BTPD8GBTSY206 (Shipped freight collect)



ABSOLUTELY THE MOST COST EFFECTIVE DISK SUBSYSTEM EVER OFFERED BY PRIORITY ONE ELECTRONICS



YOU SAVE \$1419.77!!

- 2 Double sided 8" QUME DT8 disk drives
- DMA Floppy Controller (controls up to 4 drives)
- CP/M 2.2[®] w/BIOS written for the Disk 1 Controller
- Cabinet includes power supply & internal data cable
- External data cable included

1 BGT206SP	List Price \$2325.00
1 BGT171A	\$485.00
1 BGTCPM80	\$175.00
1 PC650606	\$ 19.77

\$3014.77

CABINET AND 2 QUME DT8 DOUBLE SIDED DRIVES PROVIDE 2.4 MBYTES OF MASS STORAGE!! **\$1295.00** SAVE \$1030.00!! BTGBT206SP (St. Wt. 50 lbs.) List Price: \$2325.00



STATIC RAM SALE!!

IEEE/696 S-100 - ULTRA LOW POWER!

256K RAM 22

12 MHz

- Fully static design eliminates timing problems associated with Dynamic RAMs (<4 Watts)
- Guaranteed to work with any IEEE/696 S-100 DMA device
- 24 bit extended addressing
- 8 or 16 bit data
- Single 5V operation
- Assembled and Tested

SUPER SALE PRICE:

\$1500.00

EACH, WHEN YOU BUY 2 OR MORE

NEW!

\$1595.00

Each

BTGBT190A

128K RAM 21

12 MHz

- Fully static design uses less power than dynamics (1.2A typical)
- 24 bit extended addressing
- 8 or 16 bit data
- 16K window deselect
- Switch selectable PHANTOM disable
- Fully DMA compatible
- Assembled and Tested

SUPER SALE PRICE:

\$650.00

EACH, WHEN YOU BUY 2 OR MORE

\$695.00

Each

BTGBTRAM21 LIST PRICE: \$1295.00

64K 10MHz LOW POWER S-100 IEEE/STATIC RAMS

RAM 17

64K 8 BIT / 24 BIT ADDRESS
BTGBTRAM17 List Price: \$499.00

\$299.00

RAM 16

64K 8 or 32K 16 BIT / 24 BIT ADDRESS
BTGBTRAM16 List Price: \$550.00

\$325.00



CVT POWER SUPPLY

NEW! Power Supply Specifications: NEW!

For 12 Slot MICROFRAMES: 8V @ 17A ±16V @ 2A
For 22 slot MICROFRAMES: 8V @ 30A ±16V @ 4A

AC input may range from 70 - 140 VAC

Part No.	Description	Price
BTNDLMCS112	12 slot desk top (Sh. Wt. 26 lbs.)	\$737.00
BTNDLMCS122	22 slot desk top (Sh. Wt. 44 lbs.)	\$881.00
BTNDLMR12	12 slot rack mount (Sh. Wt. 38 lbs.)	\$879.00
BTNDLMR22	22 slot rack mount (Sh. Wt. 46 lbs.)	\$1036.00

12 SLOT MICROFRAME WITH CUTOUTS FOR THREE 5 1/4" DRIVES

This MICROFRAME is for applications where space is a limitation. The power supply supports the S-100 bus, and three floppy or Winchester disk drives. Each power supply output for the drives are ±5V @ 4A, and +12V @ 8A. The S-100 supply provides +8V @ 15A and ±16V @ 2A.

BTNDLTF12	12 slot desk top (Sh. Wt. 41 lbs.)	\$980.00
BTNDLRF12	12 slot rack mount (Sh. Wt. 46 lbs.)	\$1030.00

8" DISK DRIVE ENCLOSURE

The power supply of this enclosure has the capability to drive 4 half-height floppy disk drives, 2 Winchester hard disk drives, or a combination of 2 half-height floppies and a Winchester drive in the same cabinet. Power supply outputs are +5V @ 7A, -5V @ 3A, ±12V @ 4A, and +24V @ 8A.

BTNDLDE8	Desk top disk enclosure (45 lbs.)	\$910.00
BTNDLDE8R	Rack mount disk enclosure (45 lbs.)	\$1015.00

INTERNATIONAL INSTRUMENTATION, INC.

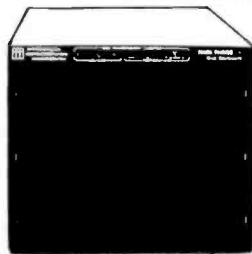

THIN THREE 8" DRIVE CABINET

- Supports 3 half-high 8" disk drives • 5V @ 6A, -5V @ 1A, 24V @ 6A
- One AC power connector for one full size drive • 5V output over-voltage protected
- Optional disk environmental monitor is available to monitor and alarm you to internal temperature reaching dangerous levels

Part No.	List Price	SALE PRICE
BTIIUDETTT	\$495.00	\$375.00
WITH DISK ENVIRONMENTAL MONITOR:		
BTIIUDETTTMM	\$584.95	\$425.00



PRIORITY ONE ELECTRONICS

9161 Deering Ave., Chatsworth, CA 91311



ORDER TOLL FREE (800) 423-5922 - CA, AK, HI CALL (213) 709-5111

Terms: U.S. VISA, MC, BAC, Check, Money Order, U.S. Funds Only. CA residents add 6 1/2% Sales Tax. MINIMUM PREPAID ORDER \$15.00. Include MINIMUM SHIPPING & HANDLING of \$3.00 for the first 3 lbs. plus 40¢ for each additional pound. Orders over 50 lbs. sent freight collect. Just in case, include your phone number. Prices subject to change without notice. We will do our best to maintain prices through August 1, 1983. Many quantities are limited. Sorry, no alcheks, no refunds or exchanges on sale merchandise. Credit Card orders will be charged appropriate freight. Sale prices for prepaid orders only. We are not responsible for typographical errors on sale merchandise. Circle 322 on inquiry card.

Circle 322 on inquiry card.

RETAIL STORE PHONE NUMBERS: (Chatsworth:) (213) 709-5464 - (Irvine:) (714) 660-1411

SIXTH ANNIVERSARY SALE!

NOT JUST AN ORDINARY SALE! WE HAVE **SLASHED PRICES TO THE BONE** AS OUR WAY OF THANKING YOU, OUR VALUED CUSTOMERS FOR 6 YEARS OF LOYALTY. WE'VE CONTINUOUSLY GROWN AND EXPANDED BY OFFERING YOU THE BEST VALUE FOR YOUR MONEY WITH THE BEST AFTER-SALE SUPPORT

SIEMENS FDD100-8 8" FLOPPY DISK DRIVE

SINGLE SIDED, DOUBLE DENSITY
SHUGART 801R COMPATIBLE

90 DAY WARRANTY!

ONCE AGAIN, YOU RECEIVE THE
BENEFIT OF OUR UNEQUALLED
PURCHASING
POWER!



\$175.00 each
CALL for 10+

OEM INQUIRIES INVITED
(Include \$7.00 per drive for shipping)
BTSIEFDD1008

ORDER NOW AND SAVE!

BUY DRIVE & CABINET TOGETHER AND \$SAVE!!

DUAL 8" SIEMENS FDD1008
DUAL 8" CABINET POWER SUPPLY
AND INTERNAL POWER CABLES

(Include \$30.00 for shipping)

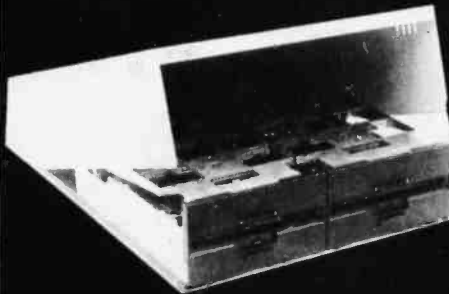

- Positive Pressure Filter Cooling
- Power Supply 4A@+5V, 3A@+24V, 1A@-5V
- Each output is individually fused
- Hinged for easy access
- Heavy non-flex .090 aluminum base
- Modular power connectors

IF BOUGHT SEPARATELY: \$890.00
ANNIVERSARY SALE PRICE:

\$625.00

BTPOBIIISIE (Include \$30.00 for shipping)
BTIIIFDE002 CABINET ONLY (Sh. Wt. 38 lbs.) **\$295.00**

S-100 DUAL 8" SUBSYSTEM

BTCGS2422A
BTSIEFDD1008
BTIIIFDE002

S-100 Disk Controller with CP/M 2.2®
Siemens Double Density 8" drive
Dual Horizontal Cabinet
with Power Supply
and Data Cable

1 \$338.00
2 \$350.00
1 \$295.00

1 \$35.00
\$1018.95

**DON'T
MISS OUT!**

Order No.
BTPDBSIESUBI



OUR FINEST DUAL 8" DISK DRIVE CABINET!

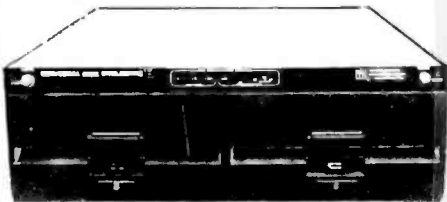

FEATURES:

- Positive pressure forced air cooling for reliable disk drive operation
- AC input via 3 wire 7 foot international cord/socket set
- AC input EMI filtered to six amps to help prevent disk crashes due to power spikes and line noise
- 14 gauge main chassis
- Integral power supply with 5V @ 6A-5V @ 1A/24V @ 6A
- Double-sided custom PC power board and Supply
- Each DC supply and AC separately fused

Part No. **BTIIUDE004** (Sh. Wt. 40 lbs.) **List Price \$495.00** **Our Price \$349.00**

With augmented power supply to handle Tandem Slimline, or Winchester disk drives. Includes the disk environment monitor.
BTIIUDE004AUG (Sh. Wt. 40 lbs.) **\$733.00** **\$825.00**

With Disk Environment Monitor for cool, reliable operation
BTHIUE004EM (Sh. Wt. 40 lbs.) **\$584.95** **\$395.00**

S-100 HARD DISK SUBSYSTEMS



by **MORROW**
**COMPLETE WITH S-100
CONTROLLER, CP/M 2.2®
AND MICROSOFT BASIC V5.2**

Part No.	Description	List Price	Our Price
BTMDSM20S	20 Mbyte 8"	\$495.00	\$3250.00

(Shipping Weights: M20: 37 lbs., M26 (3 boxes): 8, 26, & 45 lbs. each)

ADD-ON DRIVES

(Does not include software and controller)

BTMDSABM10	10 Mbyte 8"	\$2795.00	\$2050.00
BTMDS14M26	26 Mbyte 14"	\$3495.00	\$2675.00

(Shipping Weights: M10: 37 lbs. M26, (2 boxes): 26, & 45 lbs. each)

DISK DRIVES

TANDON 5 1/4" HARD DISK

BTNDTM501	1 platter 6 Mbyte (Sh. Wt. 9 lbs.)	\$749.00
BTNDTM502	2 platter 12 Mbyte (Sh. Wt. 9 lbs.)	\$895.00
BTNDTM503	3 platter 19 Mbyte (Sh. Wt. 9 lbs.)	\$1049.00

DUAL HARD DISK ENCLOSURE

BTIIHD5002	For above drives	\$395.00
------------	------------------	-----------------

TANDON 5 1/4"

BTNDTM1001	1 Sided 48 TPI	\$225.00	2 FOR \$195.00 each
BTNDTM1002	2 Sided 48 TPI	\$260.00	2 FOR \$235.00 each
BTNDTM1003	1 Sided 96 TPI	\$275.00	2 FOR \$250.00 each
BTNDTM1004	2 Sided 96 TPI	\$390.00	2 FOR \$365.00 each

(Shipping Weights on above items: 5 lbs. each)

MPI 5 1/4" FULL HEIGHT

BTMPI51*	1 Sided 48 TPI	\$200.00
BTMPI52*	2 Sided 48 TPI	\$270.00
BTMPI91*	1 Sided 96 TPI	\$275.00
BTMPI92*	2 Sided 96 TPI	\$400.00

*Replace with an "M" for the MPI style bezel, or with an "S" for Shugart style bezel. (Shipping Weight: 5 lbs.)

MPI 5 1/4" HALF HEIGHT

BTMPI501	1 Sided 48 TPI (Sh. Wt. 4 lbs.)	\$260.00
BTMPI502	2 Sided 48 TPI (Sh. Wt. 4 lbs.)	\$300.00
BTMPI901	1 Sided 96 TPI (Sh. Wt. 4 lbs.)	\$300.00
BTMPI902	2 Sided 96 TPI (Sh. Wt. 4 lbs.)	\$355.00

SHUGART 8" FULL HEIGHT

BTSHU801R	1 sided (18 lbs.)	\$369.00
-----------	-------------------	-----------------

QUME 8" FULL HEIGHT

BTQMEDT8	2 sided (18 lbs.)	\$480.00
		2 FOR \$460.00 ea.

MITSUBISHI 8" FULL HEIGHT

BTMITM289483B	2 sided (18 lbs.)	\$380.00
---------------	-------------------	-----------------

MPI 8" FULL HEIGHT

BTMPI41S	1 sided (11 lbs.)	\$390.00
BTMPI42S	2 sided (11 lbs.)	\$460.00

MPI 8" DUAL HALF HEIGHT

(SAME SIZE AS ONE FULL HEIGHT)

BTMPI41D	1 sided (22 lbs.)	\$760.00
BTMPI42D	2 sided (22 lbs.)	\$970.00

TANDON 8" HALF HEIGHT

BTNDTM8401	1 sided (9 lbs.)	\$395.00
		2 FOR \$375.00 ea.

BTNDTM8482	2 sided (9 lbs.)	\$495.00
		2 FOR 475.00 ea.

MPI 8" HALF HEIGHT

BTMPI41M	1 sided (11 lbs.)	\$380.00
BTMPI42M	2 sided (11 lbs.)	\$460.00

5 1/4" DRIVE CABINETS

BTJMR1C5	Single 5 1/4" Cabinet (5 lbs.)	\$69.00
BTJMR2C5	Dual 5 1/4" Cabinet (9 lbs.)	\$88.00
BTJMR2C5C	JMR2C5 w/internal data cable (9 lbs.)	\$99.00

DUAL 8" HALF HEIGHT FLOPPY CABINET

- 24V @ 4A, 5V @ 3A
- -5V @ 800ma
- Fan cooled
- Socketed power connections
- All supplies regulated

	List Price	Our Price
BTIIIDL002 Dual Thin Line Cabinet (12 lbs.)	\$225.00	\$185.00

BUY THE CABINET & DRIVES AND \$SAVE! With 2 Tandem Thinlines

BTPOBIIITND1	Cabinet w/2 TNDTM8481 - 1 sided (30 lbs.)	\$ 885.00
BTPOBIIITND2	Cabinet w/2 TNDTM8482 - 2 sided (30 lbs.)	\$1115.00

With 2 MPI Slimlines

BTPOBIIIMP1	Cabinet w/2 MPI41M - 1 sided (30 lbs.)	\$ 920.00
BTPOBIIIMP2	Cabinet w/2 MPI42M - 2 sided (30 lbs.)	\$1080.00

Options

BTHIIDLMPKIT	MPI drive adaptor mounting kit (2 lbs.)	\$24.95
BTHIIOCCSHU	Shugart / AC/DC power connector kit (2 lbs.)	\$14.95

(For full size single SA801 or compatible drives)

RETAIL STORE PHONE NUMBERS: (Chatsworth:) (213) 709-5464 - (IRVINE:) (714) 660-1411

PRIORITY ONE IS NUMBER 1!

OTHERS COME AND GO, WHILE WE HAVE BECOME THE LARGEST MAIL-ORDER DISTRIBUTOR IN THE MICRO-COMPUTER INDUSTRY. ORDER WITH CONFIDENCE. WHEN YOU HAVE A QUESTION, WE'LL BE HERE NEXT WEEK, NEXT MONTH AND NEXT YEAR! WE'RE NUMBER 1 AND STILL TRYING HARDER!

APPLE II/IIe DISK DRIVES

Drive, Cartridges, DMA Controller, Cabinet and Power Supply
FULLY APPLE II COMPATIBLE

ADD-ON DRIVE

BTVIS3101 (Shipping Weight 6 lbs.) **\$229.00**

DISK DRIVE WITH CONTROLLER

BTVIS3111 (Shipping Weight 7 lbs.) **\$289.00**

BTVISAFDC Apple II Drive Controller **\$79.00**

6 MEGADYTE DISK SUBSYSTEM



BTVIS1840 List Price: \$1549.00 **SALE: \$1299.00**

IBM MULTICARD

MEMORY & I/O CARD



- 64K RAM Expandable to 256K
- One RS232 Serial Port
- One Parallel Printer Port
- Real Time Clock Calendar with Battery Backup (Shipping Weight 1 lb.)

BTVIS025665 List Price: \$595.00

ANNIVERSARY SALE PRICE:

\$329.00

IBM MAXICARD

PERSONAL COMPUTER RAM CARD

POPULATED IN 64K, 256K, or 576K

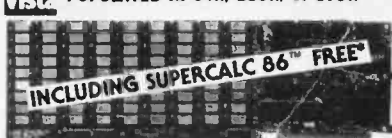

- Runs at full speed with no wait states
- Parity can be disabled at User's option
- On board parity bit on each Byte
- Fully expanded, a full 576 KB on one card
- One board fills entire primary RAM address space available
- Full Vista 120 Day Warranty

64K \$219.00

BTVIS057664 List Price: \$379.00

SAVE \$160.00!!

256K \$489.00

BTVIS076256 List Price: \$789.00

SAVE \$320.00!!

576K \$849.00

BTVIS0576576 List Price: \$1299.00

SAVE \$450.00!!

* Available with 256K & 576K boards only (Sh. Wt. 6 lbs.)
(IBM is a trademark of International Business Machines)

5 1/4" FLOPPY DISKETTES

ULTRA MAGNETICS **DOUBLE DENSITY!** **LIFETIME WARRANTY!**

- FEATURES:
- Includes reinforcement ring
 - 100% Surface tested
 - Write protect with tabs
 - Lifetime warranty!

SINGLE SIDED

40 TRACKS — 1 BOX
DOUBLE DENSITY OF 10: **\$ 25.00**

2 BOXES: **\$ 40.00**

10 BOXES: **\$180.00**

ORDERING INFORMATION

BTULTS1401 Soft Sector

BTULTS1410 10 Sector

BTULTS1416 16 Sector

BTULTS2401

BTULTS2410

BTULTS2418

Soft sector, 40 track, 2 sided

10 sector, 40 track, 2 sided

16 sector, 40 track, 2 sided

1 BOX OF 10 2 BOXES 10 BOXES

\$35.00 \$60.00 \$280.00



PRIORITY ONE ELECTRONICS



9161 Deering Ave., Chatsworth, CA 91311

ORDER TOLL FREE (800 423-5922 - CA, AK, HI CALL (213) 709-5111

Terms: U.S. VISA, M.C. BAC, Check, Money Order, U.S. Funds Only. CA residents add 6 1/2% Sales Tax. MINIMUM PREPAID ORDER \$15.00. Include MINIMUM SHIPPING & HANDLING of \$3.00 for the first 3 lbs plus 40¢ for each additional pound. Orders over 50 lbs. sent freight collect. Just In case, please include your phone number. Prices subject to change without notice. We will do our best to maintain prices through August, 1983. Credit Card orders will be charged appropriate freight. Sale prices for prepaid orders only. We are not responsible for typographical errors. Circle 322 on inquiry card.

MONITORS

COLOR MONITORS



TAXAN

Part No.	Description	List Price	Our Price
BTTAXR6B1	12" med res. RGB (29 lbs.)	\$399.00	\$328.95
BTTAXR6B3	12" high res. RGB (29 lbs.)	\$699.00	\$499.87
BTTAX10-03	Apple II RGB int. w/cable (1 lb.)		\$125.00
BTTAX10-80	Apple IIe & IIc 80 col. RGB int. (1 lb.)		\$179.00
BTTAX18R6B	IBM PC™ RGB Cable (1 lb.)		\$18.00
BTTAXR6BAPL	Apple IIe & III RGB Cable (1 lb.)		\$19.00

SANYO

BTSY0YMC7013	13" NTSC w/sound (35 lbs.)	\$650.00	\$499.00
BTSY0DM6113	13" RGB (35 lbs.)	\$795.00	\$549.00
BTSY0AVM255	25" RGB/NTSC (25" Monitor shipped freight collect)	\$795.00	\$699.00
BTSY0DM8112CX	12" green (24 lbs.)	\$260.00	\$159.00



SERIES 10 PROGRAMMABLE CALCULATORS

Part No.	Description	List Price	Our Price
BT HP-10C	Scientific	\$ 70.00	\$59.00
BT HP-11C	Adv. scientific	\$ 90.00	\$79.00
BT HP-12C	Adv. financial	\$120.00	\$99.00
BT HP-15C	Adv. sci. w/matrix	\$120.00	\$99.00
BT HP-16C	Digital & Computer science	\$120.00	\$99.00

(Shipping Weights on above calculators: 3 lbs. each)

HP-41C/CV HANDHELD COMPUTER SYSTEM

BT HP-41C	Handheld computer	\$195.00	\$159.00
BT HP-41CV	Handheld computer w/5x the memory	\$275.00	\$219.00
BT HP82104A	Card reader	\$195.00	\$159.00
BT HP82153A	Optical Wand	\$125.00	\$ 99.00
BT HP82161A	Cassette drive	\$450.00	\$349.00
BT HP82182A	Thermal Printer	\$450.00	\$349.00
BT HP82183A	Video Interface	\$225.00	\$179.00

(Shipping Weights on above items 5 lbs. each)

ENHANCEMENT MODULES:

BT HP82160A	HP-IL module	\$125.00	\$95.00
BT HP82170A	Quad RAM module	\$ 75.00	\$59.00
BT HP82180A	Extended functions/ memory module	\$ 75.00	\$59.00
BT HP82181A	Ext. memory module	\$ 75.00	\$59.00
BT HP82182A	Time module	\$ 75.00	\$59.00

(Shipping Weights on above items: 1 lb. each)

HP-75C PORTABLE COMPUTER

BT HP-75C	(Sh. Wt. 9 lbs.)	List Price: \$995.00	\$795.00
ACCESSORIES FOR HP-75C			
BT HP00075-15014	VisiCalc® ROM for HP-75C		\$195.00
BT HP00075-15019	Text formatter for HP-75C		\$ 99.00
BT HP00075-15012	Surveying Pac for HP-75C		\$295.00
BT HP00075-15015	Math Pac for HP-75C		\$145.00
BT HP00075-15035	Data Communications Pac for HP-75C		\$145.00
BT HP00075-13018	Graphics solutions book		\$ 45.00

(Shipping weights for above items 1 lb. each)

PRINTERS



COEX

80 F/T

DOT

MATRIX

PRINTER



BTCOX80FT	Parallel Interface 80 cps (21 lbs.)	\$289.00
BTCOX80FTSER	Serial Interface 80 cps (21 lbs.)	\$289.00
BTCOXAPLINTP	Apple II Parallel Interface (1 lb.)	\$49.95



GEMINI 10 & 15

BTGEM10X	120 cps Parallel Int. 80 col. (20 lbs.)	\$319.00
BTGEM15	100 cps Parallel Int. 132 col. (26 lbs.)	\$459.00
BTGEMSERINT	Serial interface card for GEM10X and GEM15 (1 lb.)	\$85.00



\$229

BTAXMGPI00A 30 cps 8 col. dot matrix (11 lbs.) **\$229.00**

OKIDATA

BTOKIDAT82AT	TRACTOR INCLUDED (25 lbs.)	\$449.00
BTOKIDAT83AT	TRACTOR INCLUDED (35 lbs.)	\$729.00
BTOKIDAT82AP	OKIDATA 92A Parallel (25 lbs.)	\$480.00
BTOKIDAT82AS	OKIDATA92A Serial (25 lbs.)	\$599.00
BTOKIDAT82AT	OKIDATA92A Tractor (2 lbs.)	\$ 79.95
BTOKIDAT93AP	OKIDATA93A parallel (35 lbs.)	\$930.00
BTOKIDAT93AS	OKIDATA93A Serial (35 lbs.)	\$995.00

MANNESMANN TALLY

LETTER QUALITY DOT MATRIX PRINTER

• 160 cps	• Tractor and friction feed	
• 40 cps (Letter quality)	• "Bullet-Proof" cast frame with metal cabinet	
• Serial & Parallel Interface		
• Double wide characters		
BTTALMT160L	160 cps 80 col. (21 lbs.)	\$569.00
BTTALMT180L	160 cps 132 col. (28 lbs.)	\$784.00

QUME LETTER QUALITY PRINTER

BTQMES945	45 cps Sprint 9 (49 lbs.)	\$1799.00
BTQMES955	55 cps Sprint 9 (49 lbs.)	\$2195.00
BTQMES1140	40 cps Sprint 11 (45 lbs.)	\$1389.00
BTQMES11RS232	RS232 Module for Sprint 11 (3 lbs.)	\$ 99.00
BTQMES11CENT	Centronics parallel for Sprint 11 (3 lbs.)	\$ 99.00
BTQMES11IEEE488	IEEE488 Module for Sprint 11 (3 lbs.)	\$ 99.00
BTQMES11IBM	IBM module for Sprint 11 (3 lbs.)	\$ 99.00
BTQMEBDT	Bi-Directional Tractor (9 lbs.)	\$ 349.00
BTQMEWB	Wire basket (2 lbs.)	\$ 85.00
BTQMECSF	Cut Sheet Feeder (20 lbs.)	\$ 849.00

RETAIL STORE PHONE NUMBERS: (Chatsworth:) (213) 709-5464 - (IRVINE:) (714) 660-1411

NOT JUST AN ORDINARY SALE! WE HAVE SLASHED PRICES TO THE BONE AS OUR WAY OF THANKING YOU, OUR VALUED CUSTOMERS FOR 6 YEARS OF LOYALTY. WE'VE CONTINUOUSLY GROWN AND EXPANDED BY OFFERING YOU THE BEST VALUE FOR YOUR MONEY WITH THE BEST AFTER-SALE SUPPORT



THE LEMON™ SOURS SURGES!

NEW!
From
EPD
Electronic Protection Devices

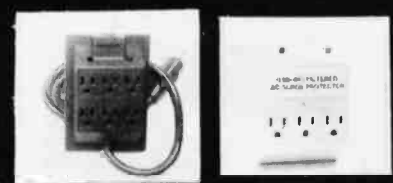

AC SURGE PROTECTORS

Part No.	Description	List Price	Our Price
BTEPDLEMON	6 outlet wall mount	\$59.95	\$44.95
BTEPDLIME	6 outlet 4 1/2" cord w/power switch (Shipping Weight: 4 lbs each)	89.50	\$69.95

EMI-RFI FILTERED AC SURGE PROTECTOR

BTEPDORANGE	6 outlet 4 1/2" cord w/power switch	\$139.95	\$104.95
BTEPPEACH	6 outlet wall mount (Shipping Weight: 4 lbs each)	\$97.50	\$ 74.95

The LEMON, LIME, ORANGE, and PEACH are solid state and EMI-RFI noise filters designed to protect all mini and micro computers, word processors, printers, disc drives, and other computer-controlled equipment that is plugged into an AC power line. There may be nothing more terrifying than to lose all of your software or data files due to a high voltage spike or noise from an adjacent elevator, air conditioner, or any other high powered equipment being operated in the nearby area. With a LEMON, LIME, ORANGE, or PEACH, you can be sure that the FRUITS of your computer labor will be protected from most voltage spikes and EMI-RFI interferences.

TERMINALS

VISUAL 50

BEST BUY!



BTVSL50BW	Black & White 12"	\$695.00 (41 lbs)	\$625.00
BTVSL50GN	Green Screen 12"	\$770.00 (41 lbs)	\$655.00

FEATURE COMPARISON CHART

Features:	VISUAL 50	Hazeltine Esprit	ADDS Viewpoint	Luar Slegler ADM-5	TeleVideo 910
Tilt & Swivel	YES	NO	NO	NO	NO
Detached Keyboard	YES	NO	YES	NO	NO
N-Key Rollover	YES	NO	YES	NO	NO
Audible Key Click	YES	YES	NO	NO	NO
Menu Set-Up Mode	YES	NO	NO	NO	NO
Status Line	YES	NO	NO	NO	NO
Full 5 Attribute Selection	YES	NO	NO	NO	YES
Smooth Scroll	YES	NO	NO	NO	NO
Line Drawing Character Set	YES	NO	NO	NO	NO
Block Mode	YES	YES	NO	NO	YES
Insert/Delete Line	YES	YES	NO	NO	YES
Bi-Directional Aux. Port	YES	YES	NO	YES	NO
Columnar Tabbing	YES	YES	NO	NO	YES
Independent RCVTX Rates	YES	NO	NO	NO	NO
Answerback User Programmable	YES	NO	NO	OPT	NO

VISUAL 55 & 330

Same as above with additional insert/delete character, 12 user programmable function keys, selectable scrolling region, programmable message framing codes, and Hazeltine 1510 compatibility.

BTVSL55GM	Green screen 12"	(Sh. Wt. 41 lbs.)	\$689.00
BTVSL306M	Green 12" CRT	(Sh. Wt. 41 lbs.)	\$1200.00 \$895.00
BTVSL33016M	Green 14" CRT	(Sh. Wt. 41 lbs.)	\$1250.00 \$949.00

TELEVIDEO



BTP0BTLV0252P	w/2nd page memory kit FREE (A\$95.00 Value)	\$729.00
BTP0BTVW504P	w/2nd, 3rd, & 4th page memory kit FREE (A\$285.00 Value)	\$829.00
BTLV910	80 col. terminal	(Sh. Wt. 37 lbs.) \$558.95
BTLV970	14" 80/132 col. terminal	(Sh. Wt. 40 lbs.) \$1019.00

LIBERTY ELECTRONICS

BTLIBF50	Freedom 50 (Sh. Wt. 30 lbs.)	\$599.00	\$474.00
ADDS			
BTA00WPR	Viewpoint 3A+ (30 lbs)	\$695.00	\$575.00

QUME

NEW!!



BQMEI02	80 Column Green (Sh. Wt. 30 lbs.)	\$550.00
BQMEI02AM	80 Column Amber (Sh. Wt. 30 lbs.)	\$565.00
BQMEI03	80/132 Column Green (Sh. Wt. 30 lbs.)	\$765.00
BQMEI08	22 function key, 80 col Green (30 lbs)	\$749.00
BQMEI08AM	22 function key, 80 col Amber (30 lbs)	\$765.00

SUPER DMM SALE!



HITACHI
Hitachi Denshi, Ltd.
AUTO RANGING
3 1/2 DIGIT LCD

- Eight measurement functions with auto ranging
- Data hold feature
- Continuity beeper
- Temperature measurements (except HITVR3550)
- 5 to 1% accuracy
- 10M input impedance
- 250V overload protection on all resistance functions
- 1100 VDC or 850 VAC overload protection on volt scales

Part No.	Description (Sh. Wt. 2 lbs.)	List Price	Our Price
BTHITVR3550	5% Autoranging DMM	\$127.00	\$105.00
BTHITVR3525	25% with temp	\$157.00	\$130.00
BTHITVR3510	1% with temp	\$187.00	\$160.00
BTHIT6703	Soft carrying case		\$15.00



BTFLU8022B	Handheld DMM 25% Accuracy	\$144.00
BTFLU8021B	Handheld DMM 5% Accuracy w/cond.	\$158.00
BTFLU8020B	Handheld DMM 1% Accuracy	\$104.00
BTFLU8024B	Handheld DMM 1% Accuracy, Pk & Hold	\$249.00
(Shipping Weights on above items: 2 lbs. each)		
BTFLU8010A	10A Tru RMS Bench DMM (6 lbs.)	\$259.00
BTFLU8010A01	FLU8010A w/battery (6 lbs.)	\$299.00
BTFLU8012A	Low Ohms Tru-RMS Bench (6 lbs.)	\$339.00
BTFLU8012A01	FLU8012A w/battery (6 lbs.)	\$379.00
BTFLU8060A	4 1/2 Digit DMM w/Frequency Counter (2 lbs.)	\$349.00
BTFLU8062A	4.5 digit Handheld DMM (2 lbs.)	\$279.00
BTFLU8050A	4.5 digit Tru-RMS Bench DMM (6 lbs.)	\$389.00
BTFLU8050A01	FLU8050A w/battery (6 lbs.)	\$439.00
BTFLU8090*	Soft carrying case	(\$10.00) 1¢



BTKTH130	3.5 digit 5% Accuracy handheld DMM	\$129.00
BTKTH131	3.5 digit 25% Accuracy handheld DMM	\$139.00
BTKTH128	3.5 digit handheld DMM w/beeper	\$139.00
BTKTH132C	3.5 digit handheld DMM w/thermometer (Cent.)	\$189.00
BTKTH132F	3.5 digit handheld DMM w/thermometer (Far)	\$209.00
BTKTH135	4 1/2 digit handheld DMM	\$239.00
(Shipping Weights for above items: 2 lbs. each)		
BTKTH169	3.5 digit bench LCD DMM	\$189.00
BTKTH176	4.5 digit bench LCO DMM	\$298.00
BTKTH179A	4.5 digit bench LED DMM	\$359.00
BTKTH1911910	5.5 digit bench DMM	\$870.00
BTKTH1911820	5.5 digit bench true RMS	\$940.00
(Shipping Weights for above items: 6 lbs. each)		
BTKTH1304*	Soft carrying case	(\$10.00) 1¢

BUY A SOFT CARRYING CASE FOR 1¢
*With the purchase of any Fluke or Keithley Handheld DMM!

MODEMS



U.S. ROBOTICS

Part No.	Description	List Price	SALE PRICE
BTUSRADIAL212A	1200 baud Auto Orig/Answer	\$599.00	\$495.00
BTUSRPASSWRO	1200 baud Auto Orig/Answer	\$449.00	\$379.00
BTUSRTELPACB	Password Comm. Software 8" CPM	\$ 79.00	
BTUSRTELPACSA	Password Comm. Software 5 1/4" Apple	\$ 79.00	
BTUSRMLNK300	Micro Link 300 Baud	\$179.00	\$159.00
BTUSRMLNK1200	Micro Link 1200 Baud	\$449.00	\$369.00
BTUSRALNK300	Auto Link 300 Baud	\$219.00	\$175.00
BTUSRALNK1200	Auto Link 1200 Baud	\$499.00	\$399.00

(Shipping Weights on above items: 4 lbs. each)
SEE PAGE 30 OF THIS MONTH'S BYTE FOR MORE INFORMATION

D.C. HAYES

BTDCN0400P	1200 Baud Smartmodem	\$695.00	\$514.95
BTDCN0200P	300 Baud Smartmodem	\$279.00	\$229.00
BTDCN0300P	Chronograph	\$249.00	\$199.00
BTDCN0100P	MicroModem 100	\$399.00	\$349.00
BTDCN0000P	MicroModem II	\$379.00	\$299.00

RIXON



1200 BAUD AUTO DIAL DIRECT CONNECT MODEMS WITH 10 NUMBER MEMORY

BTRIXR212A	1200 Baud Stand Alone unit	\$495.00	\$475.00
BTRIXPC212A	1200 IBM PC™ modem (2 lbs.)	\$495.00	\$475.00
BTRIXPCOM1	IBM PC™ Modem Software (1 lb.)	\$ 89.00	
BTP0BRIXIBM	IBM Modem & Software Together (3 lbs.)	\$539.00	

SEE PAGE 445 OF THE JULY ISSUE OF BYTE FOR MORE INFORMATION

MURA DIRECT CONNECT MODEM \$79.00

- 0 - 300 BAUD MURA MM-100**
- 0 - 300 Baud
 - RS232C interface
 - Full duplex
 - Carrier detect indicator
 - Bell 103 compatible
 - Low voltage
 - Originate/Answer switch selectable

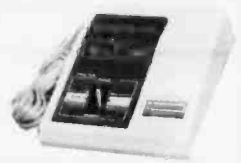

Part No.	Description	List Price	Our Price
BTMURMM100 0	0 - 300 baud modem (2 lbs)	\$99.95	\$79.00
BTCNORS2326F	RS232C cable		\$19.95

PRIORITY ONE IS YOUR PROTOTYPING SUPER-MARKET

page PLUGBOARDS

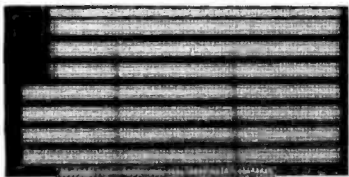

S-100 PLUGBOARDS

PART NO.	DESCRIPTION	1-4	5-9	10-24
BTP6BP1001	S-100 Bare Board	\$15.95	\$13.95	\$11.95
BTP6BP1002	S-100 Horizontal Busses	\$22.95	\$19.95	\$17.95
BTP6BP1003	S-100 Vertical Busses	\$22.95	\$19.95	\$17.95
BTP6BP1004	S-100 Pads Per Hole	\$23.95	\$20.95	\$18.95

APPLE PLUGBOARDS

BTP6BP5001	Apple bare board	\$15.95	\$13.95	\$11.95
BTP6BP5002	Apple horizontal busses	\$22.95	\$19.95	\$18.95
BTP6BP5004	Apple pads per hole	\$23.95	\$20.95	\$18.95

UNIVERSAL PLUGBOARDS

4.5" x 6.5" or 9.6" edge connector as indicated for 3", 4", 6", 9" dips. Accommodates 1" IDC connectors at top of board.

BTP6BP4411	4.5"x6" 22/44.156" bare board	\$ 8.85	\$ 8.95	\$ 7.95
BTP6BP4413	4.5"x6" 22/44.156" 2 holes per pad vertical busses	\$13.95	\$12.50	\$11.50
BTP6BP4414	4.5"x6" 22/44.156" pad per hole	\$14.95	\$13.50	\$12.50
BTP6BP4421	4.5"x9.6" 22/44.156" bareboard	\$10.95	\$ 9.95	\$ 8.95
BTP6BP4423	4.5"x9.6" 22/44.156" 2 holes per pad vertical busses	\$14.95	\$13.50	\$12.50
BTP6BP4424	4.5"x9.6" 22/44.156" pad per hole	\$15.95	\$14.50	\$13.50
BTP6BP5111	4.5"x6" 28/56 125 STD bareboard	\$11.85	\$10.95	\$ 9.95
BTP6BP5113	4.5"x6" 28/56 125 STD 2 holes per pad vertical busses	\$15.95	\$14.50	\$13.50
BTP6BP5114	4.5"x6" 28/56 125 STD pd/hole	\$18.95	\$15.50	\$14.50
BTP6BP7211	4.5"x6" 36/72.1" bareboard	\$ 8.85	\$ 8.95	\$ 7.95
BTP6BP7213	4.5"x6" 36/72.1" 2 holes per pad vertical busses	\$13.95	\$12.50	\$11.50
BTP6BP7214	4.5"x6" 36/72.1" pad per hole	\$14.95	\$13.50	\$12.50
BTP6BP7221	4.5"x9.6" 36/72.1" bareboard	\$10.95	\$ 9.95	\$ 8.95
BTP6BP7223	4.5"x9.6" 36/72.1" 2 holes per pad vertical busses	\$14.95	\$13.50	\$12.50
BTP6BP7224	4.5"x9.6" 36/72.1" pad per hole	\$15.95	\$14.50	\$13.50

VECTOR IDM PC™ PLUGBOARDS

4.2" x 13.325" FR4 drilled & plated holes 31/62 contacts on .1 centers complete with card guide and mounting bracket that accepts "D" connectors.

PART NO.	DESCRIPTION	1-5	6-24	25+
BVTC4813	IBM 3 holes per pad with horiz busses /soldering 44 16 pin dip capacity	\$39.00	\$35.10	\$31.20
BVTC4813-1	IBM bare board 84 16 pin dips	\$26.95	\$24.26	\$21.56
BVTC4813-2	IBM horizontal busses for wire wrap 55 16 pin dip capacity	\$36.95	\$33.26	\$29.56

IDC HEADER CONNECTORS



RIGHT ANGLE SOLDERTAIL GOLD HEADER

1" Spacing Mounts on PC Board & Mates with IDC Socket above.

Part No.	NO. OF PINS	PRICE			
		1-9	10-24	25-99	100-249 250-999
BTDICRAH10ST	5/10	1.20	1.10	1.00	.80 .85
BTDICRAH20ST	10/20	1.90	1.80	1.20	1.00 .85
BTDICRAH26ST	13/26	2.25	2.00	1.55	1.25 1.05
BTDICRAH34ST	17/34	2.95	2.60	2.05	1.70 1.45
BTDICRAH40ST	20/40	3.60	3.00	2.40	2.00 1.70
BTDICRAH50ST	25/50	4.30	3.60	3.00	2.50 2.10

RIGHT ANGLE WIRE WRAP GOLD HEADER

Part No.	NO. OF PINS	PRICE			
		1-9	10-24	25-99	100-249 250-999
BTDICRAH10WW	5/10	2.60	2.35	2.10	1.80 1.50
BTDICRAH20WW	10/20	4.00	3.50	2.75	2.20 1.80
BTDICRAH26WW	13/26	5.00	4.30	3.50	2.90 2.40
BTDICRAH34WW	17/34	5.95	5.00	4.15	3.20 2.70
BTDICRAH40WW	20/40	7.00	6.00	4.90	4.00 3.40
BTDICRAH50WW	25/50	7.95	6.50	5.90	5.00 4.00

CALL FOR STRAIGHT HEADERS NOT LISTED

16 PIN TIN DIP SOLDERTAIL SOCKETS



Qty	TIN	PRICE
50 (Sh. Wt. 4 oz)	B7T1S16LP	\$ 8.00
1000 (Sh. Wt. 4 lbs)		\$ 60.00
4500 (Sh. Wt. 15 lbs)		\$225.00

RS232 and "D" SUB-MINIATURE CONNECTORS

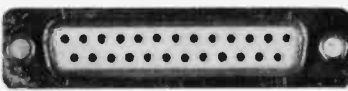

P=Plug, Male Type — S=Socket, Female Type

Part No.	No. Of Pins	PRICE				
		1-9	10-24	25-99	100-249	250-999 1000+
BTCNDD9P	9	\$2.00	\$1.80	\$1.45	\$1.35	\$1.25 \$1.05
BTCNDD9S	9	\$2.75	\$2.40	\$2.05	\$1.85	\$1.75 \$1.60
BTCNDDA15P	15	\$2.60	\$2.30	\$2.00	\$1.80	\$1.70 \$1.55
BTCNDDA15S	15	\$3.40	\$3.00	\$2.70	\$2.50	\$2.30 \$2.15
BTCNDD25P	25	\$2.75	\$2.50	\$2.25	\$1.95	\$1.80 \$1.35
BTCNDD25S	25	\$4.00	\$3.50	\$3.25	\$3.00	\$2.60 \$2.25
BTCNDDC37P	37	\$4.50	\$4.00	\$3.60	\$3.30	\$3.05 \$2.60
BTCNDDC37S	37	\$6.00	\$5.40	\$4.80	\$4.30	\$4.00 \$3.70
BTCNDD50P	50	\$5.95	\$5.35	\$4.75	\$4.25	\$3.95 \$3.60
BTCNDD50S	50	\$7.95	\$7.20	\$6.50	\$6.00	\$5.75 \$5.50

"D" CONNECTOR HOODS



2 pc. Grey - Style A 2 pc Black - Style B 1 pc. Gray - Style C

Part No.	Pins/Style	PRICE				
		1-9	10-24	25-99	100-249	250-999 1000+
BTCNDD9C	9A	\$1.50	\$1.25	\$1.10	\$1.00	\$.90 \$.80
BTCNDDA15C	15A	\$1.50	\$1.25	\$1.10	\$1.00	\$.90 \$.80
BTCNDP25H	25A	\$1.50	\$1.25	\$1.10	\$1.00	\$.90 \$.80
BTCNDD0851226	25B	\$1.75	\$1.50	\$1.35	\$1.20	\$1.10 \$.95
BTCNDD0851212	25C	\$1.65	\$1.40	\$1.25	\$1.15	\$1.05 \$.90
BTCNDDC37A	37A	\$1.75	\$1.50	\$1.35	\$1.20	\$1.10 \$.95
BTCNDD050C	50A	\$2.00	\$1.75	\$1.50	\$1.30	\$1.15 \$1.00
BTCNDD20418	Hrdwre	\$1.00	\$.80	\$.70	\$.60	\$.50 \$.40 set 2/P

CENTRONICS/EPSON PRINTER CONNECTORS

BTCND5730380	Solder	\$9.00	\$7.50	\$6.00	\$5.25	\$4.50
BTDIC5730380	IDC	\$9.95	\$9.00	\$8.00	\$7.00	\$6.00

IDC INSULATION DISPLACEMENT D-SUBMINIATURE CONNECTORS

P=Plug, Male Type — S=Socket, Female Type — C=Cover Hood

BTDICDB25P	25	6.00	5.40	4.80	4.00	3.00
BTDICDB25S	25	6.60	6.00	5.20	4.50	3.50
BTDICDB25C	25	1.60	1.50	1.35	1.20	1.10

PLEASE CALL FOR IDC "O" CONNECTORS NOT LISTED

IDC SOCKET CONNECTORS

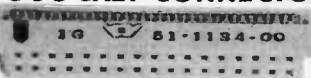

PART NO.	NO. OF PINS	PRICE			
		1-9	10-24	25-99	100-249 250-999
BTDIC10SKT	5/10	1.90	1.70	1.50	1.25 1.00
BTDIC20SKT	10/20	2.75	2.50	1.85	1.60 1.30
BTDIC26SKT	13/26	3.50	3.20	2.40	2.00 1.60
BTDIC34SKT	17/34	4.50	4.20	3.10	2.60 2.20
BTDIC40SKT	20/40	5.40	5.00	3.85	3.00 2.60
BTDIC50SKT	25/50	6.50	6.00	4.60	3.80 3.20

IDC PLUG CONNECTORS



PART NO.	NO. OF CONDUCTORS	PRICE PER SPOOL			
		10 FL	200 FL	10 FL	200 FL
BTDIC082010	10/20	5.50	5.20	4.80	4.40 4.00
BTDIC082610	13/26	8.25	5.65	5.00	4.50 4.10
BTDIC083410	17/34	7.00	6.25	5.70	5.00 4.60
BTDIC084010	20/40	7.50	6.75	6.00	5.25 4.95
BTDIC085010	25/50	8.50	7.50	6.50	6.00 5.70

CALL FOR PROTOTYPING SUPPLIES NOT LISTED

CALL FOR PROTOTYPING SUPPLIES NOT LISTED

RN ROBINSON HUGENT, INC.

GOLD/TIN 3 LEVEL WIRE WRAP SOCKETS



GOLD PLATED CONTACTS SELECTIVE PLATED PINS THAT WILL SAVE YOU MONEY BY HAVING GOLD ONLY WHERE IT COUNTS!

TIN PLATED TAILS

PART NO.	STANDARD PINS	PKG. EACH	PRICE		
			10-24	100-249	250-999
BTRNS08TWW	8	52 .55	N/A	.45	.41 .37
BTRNS14TWW	14	30 .85	.55	.50	.47 .44
BTRNS16TWW	16	26 .75	.65	.52	.51 .46
BTRNS18TWW	18	23 .90	.79	.75	.70 .65
BTRNS20TWW	20	21 1.10	.95	.91	.87 .82
BTRNS22TWW	22	19 1.25	1.15	1.05	.94 .89
BTRNS24TWW	24	17 1.25	1.15	1.05	.98 .89
BTRNS28TWW	28	15 1.50	1.45	1.35	1.25 1.15
BTRNS40TWW	40	10 2.00	1.80	1.60	1.40 1.30

*MINIMUM ORDER \$1.00 per line item. To receive quantity prices beyond 1st column you must order EXACT multiples of STANDARD PACKAGES.

ICU SERIES SOLDERTAIL LOW PROFILE D.I.P. SOCKETS



PART NO.	STANDARD PINS	PKG. EACH	PRICE			
			10-49	100-499	500-999	1,000 +
BTRNS08LP	8	52 .25	N/A	.10	.08	.075 .07
BTRNS14LP	14	30 .25	.18	.15	.14	.12 .11
BTRNS16LP	16	26 .25	.20	.18	.16	.13 .12
BTRNS18LP	18	23 .30	.25	.22	.18	.15 .13
BTRNS20LP	20	21 .30	.25	.23	.20	.17 .145
BTRNS22LP	22	19 .35	.30	.25	.22	.19 .17
BTRNS24LP	24	17 .40	.35	.30	.24	.20 .18
BTRNS26LP	26	15 .45	.40	.35	.28	.24 .21
BTRNS40LP	40	10 .50	.45	.42	.40	.35 .31

*MINIMUM ORDER \$1.00 per line item. To receive quantity prices beyond 1st column you must order EXACT multiples of STANDARD PACKAGES.

EDGECARD CONNECTOR

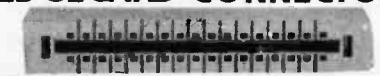

PART NO.	NO. OF PINS	PRICE			
		1-9	10-24	25-99	100-249 250-999
BTDIC10CE	5/10	3.95	3.55	3.00	2.50 2.00
BTDIC20CE	10/20	4.35	4.00	3.30	2.50 2.10
BTDIC26CE	13/26	5.00	4.25	3.50	2.70 2.30
BTDIC34CE	17/34	6.00	5.40	4.50	3.50 2.90
BTDIC40CE	20/40	6.80	6.20	5.30	4.20 3.40
BTDIC50CE	25/50	7.25	6.60	5.90	4.90 3.90

RIBBON CABLE

COLOR CODED LAMINATED CABLE FOR INSULATION DISPLACEMENT 26 GAUGE, 7 STRAND

PART NO.	NO. OF CONDUCTORS	PRICE PER SPOOL	
		10 FL	200 FL*
BTDIC10CC*	10	\$ 3.80	\$ 60.00
BTDIC14CC*	14	4.75	80.00
BTDIC16CC*	16	5.50	90.00
BTDIC20CC*	20	7.00	120.00
BTDIC25CC*	25	8.50	150.00
BTDIC26CC*	26	8.50	150.00
BTDIC34CC*	34	11.00	195.00
BTDIC40CC*	40	13.00	230.00
BTDIC50CC*	50	16.00	280.00

GRAY LAMINATED CABLE FOR INSULATION DISPLACEMENT 26 Gauge 7 Strand

PART NO.	NO. OF CONDUCTORS	PRICE PER SPOOL	
		10 FL	200 FL*
BTDIC10GY*	10	2.50	\$38.00
BTDIC14GY*	14		

The APPLE PATCH

FIX YOUR APPLE
WITHOUT COSTLY
REPAIR BILLS

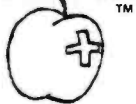

the PATCH includes:

- one of each of the IC chips found in the Apple II* and compatibles: 32 chips including the 6502 (excluding ROMs and character generator). These chips alone exceed the cost of the kit.
- Three transistors and a chip puller.
- Sixty page manual with full instructions for easy diagnosis and repair. Written by engineers who maintain hundreds of Apples.
- Packaged in attractive binder with slipcover

Even those with little or no electronic repair experience, can fix their Apple*. Don't wait until your computer is down.

Visa and Mastercharge accepted. With checks, allow two weeks for delivery. Please enclose \$2.50 for shipping and handling.

69.95

* DEALERS:
INQUIRIES INVITED

ICC

460 N. Univ. Ave. #1
Provo, UT 84601
(801) 373-1313

Circle 495 on inquiry card.

DATA SWITCH IN KIT FORM

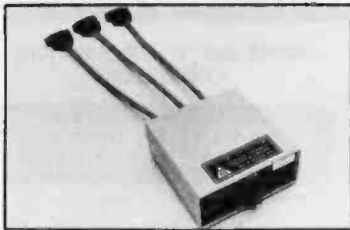

MODEL 1200 RS-232 Bidirectional Data Switch with 3-2' Extension Cables in Kit Form

Model 1200 gives the terminal or microprocessor user a second interface for a Printer, Plotter, Modem. Operates at any speed, requires no external power, while providing 2 RS-232 interfaces from the terminal or microprocessor. Built in data cables save money. The Kit consists of 3-RS-232 Male connectors with all pins, switch, cable, pre-drilled Enclosure, all necessary hardware, and assembly instructions.

To order: Specify #1200 Kit \$99.50
Assembled & Tested: Specify #1200 . \$129.00

CALL Terminal Data Corp.

11878 Conkley Circle, Rockville, MD (301) 881-7855

Circle 496 on inquiry card.

LSI C Compiler

for 8080/Z80

LSI C compiler is designed for programs with a small memory and a shorter CPU time.

- ★ The object code is compact and is faster than leading "C" compilers (Eratosthenes : 13.4sec)
- ★ typedef, static, cast and initializers are available
- ★ The compiler and the generated code run under CP/M™, but also can be burnt into PROMs.

Rational BASIC

a basic interpreter for Z80 CP/M

TEDDY

a full screen editor for 8080/Z80 CP/M

CP/M is a trademark of Digital Research

for pamphlet write:
P.O. Box 508 STA. CRUZ
CA. USA 95062

for further information contact:

LSI JAPAN CO., LTD.

2-24-9 YOYOGI SHIBUYA-KU TOKYO (151) PHONE (01)379-2427

Circle 497 on inquiry card.



The heart of your system.



LIFETIME WARRANTY

Floppy Disks

DEALERS WELCOME

SYSTEMS PRODUCT EXCHANGE

5515 N.W. 74 Ave. • Miami, FL 33166
(305) 885-4774 • 1-800-432-5115 FL

Circle 498 on inquiry card.

maxell

Floppy Disks

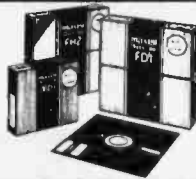

BEST PRICES IN THE U.S.

Call for our special dealer program C.O.D.'s accepted
TOLL FREE (800) 652-8168
in California (213) 706-1626



U.S. EXCHANGE
5015 Kanan Rd.
Agoura Hills, CA 91301

Circle 404 on inquiry card.

Unbelievable!!!

\$229.00



NEW

Apple II(e) SlimDisk Drive \$229.00
Amber 12" Monitor \$139.00

Apple II+
Compatible Computer with 64k,
Disk Drive, Controller, and
Monitor \$970.00

PRINTERS

Gemini 10 120 cps, 80 Column . . \$299.00
15 100 cps, 132 Column . . \$490.00



MACROTRON SYSTEMS, INC.
8143 Delmar Blvd. • St. Louis, Missouri 63130
Telephone (314) 721-3356

Terms: Prepaid Check or Money Order, Visa and MasterCard
Shipping Charge: U.S. \$2.00; C.O.D. \$3.50

Circle 499 on inquiry card.

TURN YOUR EFFORTS INTO \$\$\$

WANTED: SOFTWARE. Successful software company seeking additional products to market. Must run on IBM mainframes or PCM's. Prefer programmer/operations productivity aids. If you have written a program and you need an international company to market it for you, send an abstract of the product to:

J. Zipp
Triangle Software
4340 Stevens Creek Blvd.
Suite 108
San Jose, CA 95129
(408) 554-8121

Circle 500 on inquiry card.

Books
Reference Cards
Manuals
C and UNIX
T-Shirts

Each selection has a commentary by authorities on UNIX and C to help you select the right publication for you!

NEW NEW NEW

Responses from UNIX Commands, by Henry McGilton and Rachel Morgan, explaining UNIX's cryptic messages to its users! \$25.00 plus \$2.50 shipping and handling.

QUANTITY DISCOUNTS
AVAILABLE

No Purchase Orders under \$100.

Write or call
The UNIX Bookstore,

International Technical Seminars, Inc.,
520 Waller St., SF, CA 94117
(415) 621-6415

* International Technical Seminars is not associated with Bell Labs
* UNIX is a Trademark of Bell Laboratories

Circle 501 on inquiry card.

MODEMS

IBM-PC

Rixon PC 212A \$465.00

- * Plugs into IBM PC card slot
- * 300 and 1200 bps. asynchronous
- * Full/half duplex
- * Automatic dialer, tone or pulse, auto redial
- * Battery protected memory for number storage

PC 212A Software \$ 49.00

- * Interfaces PC 212A MODEM to PC
- * Menu driven
- * Stores telephone numbers, log-on procedures

APPLE II, APPLE II PLUS, FRANKLIN,
BELL AND HOWELL

Multi-Tech MODEM II \$265.00

- * Plugs into I/O slot
- * 300 bps asynchronous, full/half duplex
- * Automatic dialer
- * Menu driven software

Pennsylvania residents add 6% sales tax.
90-day return-to-factory warranty.
10-45 delivery. Shipped U.P.S.

Check, money order COD to
James Fox Associates
Brownsburg Road
Box 139B R.D. #2
Newtown, PA 18940

215/598-3293

JDR SUPER SPECIALS!

**THE LEADER IN
COMPUTER
COMPONENTS
BRINGS YOU THESE
FANTASTIC
SUMMERS-END
CLEARANCE BARGAINS**

OKI MSM5832RS

MICROPROCESSOR
COMPATIBLE
CLOCK/CALENDAR CHIP
3.95 100/3.25 ea.
32.768KHZ XTAL .95
OTHER CRYSTALS
3.579545MHZ .95
5.0688MHZ 1.95
18.432MHZ 1.95

78M05

VOLTAGE
REGULATOR
T1 PART #UA78M05C
STANDARD TO-220 CASE
5 VOLT AT 500MA CAN BE
USED AS 7805T IN MOST
APPLICATIONS
.29 100/.25 EA.

**ORDER TOLL FREE
800 538-5000
800 862-8279
(CA Residents)**



CONNECTORS

IDP-16 IDC DIP-PLUG .95
IDE-34 IDC EDGE-CARD 1.95
ICC-14 DIP "HEADER" .49
ICC-16 DIP "HEADER" .59
44P-ST PC EDGE-CARD 1.95
DB25PC/P VERTICAL
PC-MOUNT 1.49
DB25PC/S VERTICAL
PC-MOUNT 1.69

TRANSISTORS

2N3904 TO-92 100/7.95
2N3906 TO-92 100/7.95
PN2222 TO-92 100/7.95

CERAMIC MONOLITHIC CAPS AT THE PRICE OF DISC!

.1UF-MONO 100/12.00
.047UF-MONO 100/11.00
.01UF-MONO 100/10.00

PRIME LED'S

JUMBO RED 100/ 8.00
JUMBO YELLOW 100/12.00
JUMBO GREEN 100/12.00
5082-7760 10/ 7.95

JDR MICRODEVICES

IS PROUD TO INTRODUCE

ARK ELECTRONIC ENTERPRISES
AS AN AUTHORIZED DISTRIBUTOR
SERVING THE MIDWEST WITH HIGH
QUALITY JDR MERCHANDISE
CALL OR STOP BY



ARK
ELECTRONIC ENTERPRISES
734 Phillips Avenue
Toledo, Ohio 43612
(419) 476-6727

MICROPROCESSOR

Z80A-CPU 3.95
Z80A-CTC 3.95
Z80A-PIO 3.95
Z80A-SIO/1 12.95
Z80A-DART 6.95
8086 16-BIT 5MHZ 19.95
68A00 CPU 1.5MHZ 2.95
68A10 RAM 1.5MHZ 1.95
68A21 PIA 1.5MHZ 2.95
68A50 ACIA 1.5MHZ 2.95
6520/6820 PIA 2.95

MEMORY

2102L-4 450NS-LP .55
2111L 450NS-LP 1.49
2112 450NS 1.99
2114 450NS .99
2114-25 250NS 1.09
TMS4027 250NS .99

SPECIAL TMS4060/2107

4096 x 1 DYNAMIC
RAMS TI OR INTEL
YOUR CHOICE .69

**SPECIAL THANKS
TO MATT FOR HIS
RECENT SOFTWARE
DEVELOPMENTS
WHICH WILL ENABLE
JDR TO BETTER SERVE
OUR CUSTOMERS**

LINEAR I.C.'S

LM1800 1.95
LM1310 .99
MC1330 .99
MC1350 .89
MC1358 .99

HARD TO FIND BLACK CONDUCTIVE FOAM

14" x 26" SHEET 12.00
12" x 13" SHEET 6.00

DISK CONTROLLERS

1771 11.95
1791 18.95
1793 18.95

CRT CONTROLLERS

DP8350 19.95
CRT5027 9.95
CRT5037 9.95

D-RAM CONTROLLERS

8202 17.95
8203 32.95
3242 5.95

**Visit Our
EXPANDED
Retail Store
NEW SATURDAY
HOURS 10-3**

VISIT OUR RETAIL STORE

HOURS: M-W-F, 9-5 T-Th., 9-9 Sat. 11-3

PLEASE USE YOUR CUSTOMER NUMBER WHEN ORDERING
TERMS: For shipping include \$2 for UPS Ground or \$3 for UPS Blue Label Air. Items over 5 pounds require additional shipping charges. Foreign orders, include sufficient amount for shipping. There is a \$10 minimum order. Bay Area and Los Angeles Counties add 6 1/2% Sales Tax. Other California residents add 6% Sales Tax. We reserve the right to substitute manufacturer. Not responsible for typographical errors. Prices are subject to change without notice. We will match or

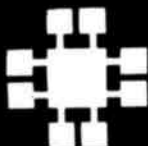

JDR Microdevices

1224 S. Bascom Ave. • San Jose, CA 95128

(408) 995-5430 • Telex 171-110

1983 JDR MICRODEVICES, INC.

4164

64K DYNAMIC 200 NS

\$595

TMM2016

2KX8 STATIC 200 NS

\$415

STATIC RAMS

2101	256 x 4 (450ns)	1.95
5101	256 x 4 (450ns) (cmos)	3.95
2102-1	1024 x 1 (450ns)	.89
2102L-4	1024 x 1 (450ns) (LP)	.99
2102L-2	1024 x 1 (250ns) (LP)	1.49
2111	256 x 4 (450ns)	2.49
2112	256 x 4 (450ns)	2.99
2114	1024 x 4 (450ns)	8/9.95
2114-25	1024 x 4 (250ns)	8/10.95
2114L-4	1024 x 4 (450ns) (LP)	8/12.95
2114L-3	1024 x 4 (300ns) (LP)	8/13.45
2114L-2	1024 x 4 (200ns) (LP)	8/13.95
2147	4096 x 1 (55ns)	4.95
TMS4044-4	4096 x 1 (450ns)	3.49
TMS4044-3	4096 x 1 (300ns)	3.99
TMS4044-2	4096 x 1 (200ns)	4.49
MK4118	1024 x 8 (250ns)	9.95
TMM2016-200	2048 x 8 (200ns)	4.15
TMM2016-150	2048 x 8 (150ns)	4.95
TMM2016-100	2048 x 8 (100ns)	6.15
HM6116-4	2048 x 8 (200ns) (cmos)	4.75
HM6116-3	2048 x 8 (150ns) (cmos)	4.95
HM6116-2	2048 x 8 (120ns) (cmos)	8.95
HM6116LP-4	2048 x 8 (200ns) (cmos)(LP)	5.95
HM6116LP-3	2048 x 8 (150ns) (cmos)(LP)	6.95
HM6116LP-2	2048 x 8 (120ns) (cmos)(LP)	10.95
Z-6132	4096 x 8 (300ns) (Qstat)	34.95

LP = Low Power Qstat = Quasi-Static

DYNAMIC RAMS

TMS4027	4096 x 1 (250ns)	1.99
UPD411	4096 x 1 (300ns)	3.00
MM5280	4096 x 1 (300ns)	3.00
MK4108	8192 x 1 (200ns)	1.95
MM5298	8192 x 1 (250ns)	1.85
4116-300	16384 x 1 (300ns)	8/11.75
4116-250	16384 x 1 (250ns)	8/11.95
4116-200	16384 x 1 (200ns)	8/12.95
4116-150	16384 x 1 (150ns)	8/14.95
4116-120	16384 x 1 (120ns)	8/29.95
2118	16384 x 1 (150ns) (5v)	4.95
4164-200	65536 x 1 (200ns) (5v)	5.95
4164-150	65536 x 1 (150ns) (5v)	6.95

5V single 5 volt supply

EPROMS

1702	256 x 8 (1us)	4.50
2708	1024 x 8 (450ns)	3.95
2758	1024 x 8 (450ns) (5v)	5.95
2716	2048 x 8 (450ns) (5v)	3.95
2716-1	2048 x 8 (350ns) (5v)	5.95
TMS2516	2048 x 8 (450ns) (5v)	5.50
TMS2716	2048 x 8 (450ns)	7.95
TMS2532	4096 x 8 (450ns) (5v)	5.95
2732	4096 x 8 (450ns) (5v)	4.95
2732-250	4096 x 8 (250ns) (5v)	8.95
2732-300	4096 x 8 (200ns) (5v)	11.95
2764	8192 x 8 (450ns) (5v)	9.95
2764-250	8192 x 8 (250ns) (5v)	14.95
2764-200	8192 x 8 (200ns) (5v)	24.95
TMS2564	8192 x 8 (450ns) (5v)	17.95
MC68764	8192 x 8 (450ns) (5v) (24 pin)	39.95
27128	16384x8 Call	Call

5v = Single 5 Volt Supply

EPROM ERASERS

	Timer	Capacity Chip	Intensity (uW/Cm ²)	
PE-14		6	5,200	83.00
PE-14T	X	6	5,200	119.00
PE-24T	X	9	6,700	175.00
PL-265T	X	20	6,700	255.00
PR-125T	X	16	15,000	349.00
PR-320	X	32	15,000	595.00

Z-80 2.5 Mhz

Z80-CPU	3.95
Z80-CTC	4.49
Z80-DART	10.95
Z80-DMA	14.95
Z80-PIO	4.49
Z80-SIO/0	16.95
Z80-SIO/1	16.95
Z80-SIO/2	16.95
Z80-SIO/9	16.95

4.0 Mhz

Z80A-CPU	4.95
Z80A-CTC	4.95
Z80A-DART	11.95
Z80A-DMA	16.95
Z80A-PIO	4.95
Z80A-SIO/0	16.95
Z80A-SIO/1	16.95
Z80A-SIO/2	16.95
Z80A-SIO/9	16.95

6.0 Mhz

Z80B-CPU	11.95
Z80B-CTC	13.95
Z80B-PIO	13.95
Z80B-DART	19.95

ZILOG

Z6132	34.95
Z8671	39.95

8000

8035	5.95
8039	6.95
INS-8060	17.95
INS-8073	24.95
8080	3.95
8085	5.95
8085A-2	11.95
8086	29.95
8087	CALL
8088	39.95
8089	89.95
8155	6.95
8155-2	7.95
8156	6.95
8185	29.95
8185-2	39.95
8741	39.95
8748	24.95
8755	24.95

8200

8202	24.95
8203	39.95
8205	3.50
8212	1.80
8214	3.85
8216	1.75
8224	2.25
8226	1.80
8228	3.49
8237	19.95
8237-5	21.95
8238	4.49
8243	4.45
8250	10.95
8251	4.49
8253	6.95
8253-5	7.95
8255	4.49
8255-5	5.25
8257	7.95
8257-5	8.95
8259	6.90
8259-5	7.50
8271	39.95
8272	39.95
8275	29.95
8279	8.95
8279-5	10.00
8282	6.50
8283	6.50
8284	5.50
8286	6.50
8287	6.50
8288	25.00
8289	49.95

CRYSTALS

32.768 khz	1.95
1.0 mhz	4.95
1.8432	4.95
2.0	3.95
2.097152	3.95
2.4576	3.95
3.2768	3.95
3.579535	3.95
4.0	3.95
5.0	3.95
5.0688	3.95
5.185	3.95
5.7143	3.95
6.0	3.95
6.144	3.95
6.5536	3.95
8.0	3.95
10.0	3.95
10.738635	3.95
14.31818	3.95
15.0	3.95
16.0	3.95
17.430	3.95
18.0	3.95
18.432	3.95
20.0	3.95
22.1184	3.95
32.0	3.95

DISC CONTROLLERS

1771	16.95
1791	24.95
1793	26.95
1795	49.95
1797	49.95
2791	54.95
2793	54.95
2795	59.95
2797	59.95
6843	34.95
8272	39.95
UPD765	39.95
MB8876	29.95
MB8877	34.95
1691	17.95
2143	18.95

CRT CONTROLLERS

6845	14.95
68845	19.95
HD46505SP	15.95
6847	11.95
MC1372	6.95
68047	24.95
8275	29.95
7220	99.95
CRT5027	39.95
CRT5037	49.95
TMS9918A	39.95
DP8350	49.95

KEYBOARD CHIPS

AY5-2376	11.95
AY5-3600	11.95
AY5-3600 PRO	11.95

CONNECTORS

RS232 MALE	2.50
RS232 FEMALE	3.25
RS232 HOOD	1.25
S-100 ST	3.95

6800

68000	59.95
6800	3.95
6802	7.95
6808	13.90
6809E	19.95
6809	11.95
6810	2.95
6820	4.35
6821	3.25
6828	14.95
6840	12.95
6843	34.95
6844	25.95
6845	14.95
6847	11.95
6850	3.25
6852	5.75
6860	9.95
6862	11.95
6875	6.95
6880	2.25
6883	22.95
68047	24.95
68488	19.95

6800 - 1MHZ

68B00	10.95
68B02	22.25
68B09E	29.95
68B09	29.95
68B10	6.95
68B21	6.95
68B45	19.95
68B50	5.95

6800 - 2 MHZ

68B00	10.95
-------	-------

6500

6502	4.95
6504	6.95
6505	8.95
6507	9.95
6520	4.35
6522	7.95
6532	9.95
6545	22.50
6551	11.85
6502A	6.95
6522A	9.95
6532A	11.95
6545A	27.95
6551A	11.95
6502B	14.95

6500 1 MHZ

6502	4.95
6504	6.95
6505	8.95
6507	9.95
6520	4.35
6522	7.95
6532	9.95
6545	22.50
6551	11.85

6500 2 MHZ

6502A	6.95
6522A	9.95
6532A	11.95
6545A	27.95
6551A	11.95

6500 3 MHZ

6502B	14.95
-------	-------

UARTS

AY3-1014	6.95
AY5-1013	3.95
AY3-1015	6.95
PT1472	9.95
TR1602	3.95
2350	9.95
2651	8.95
TMS6011	5.95
IM6402	7.95
IM6403	8.95
INS8250	10.95

GENERATORS BIT-RATE

MC14411	11.95
BR1941	11.95
4702	12.95
COM5016	16.95
COM8116	10.95
MM5307	10.95
MC4024	3.95
LM566	1.49
XR2206	3.75
8038	3.95

VISIT OUR RETAIL STORE

HOURS: M-W-F, 9-5 T-Th., 9-9 Sat. 11-3

PLEASE USE YOUR CUSTOMER NUMBER WHEN ORDERING
TERMS: For shipping include \$2 for UPS Ground or \$3 for UPS Blue Label Air. Items over 5 pounds require additional shipping charges. Foreign orders, include sufficient amount for shipping. There is a \$10 minimum order. Bay Area and Los Angeles Counties add 6 1/2% Sales Tax. Other California residents add 6% Sales Tax. We reserve the right to substitute manufacturer. Not responsible for typographical errors. Prices are subject to change without notice. We will match or beat any competitor's price provided it is not below our cost.

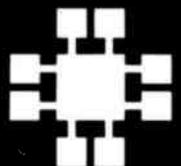

JDR Microdevices

1224 S. Bascom Ave. • San Jose, CA 95128
(408) 995-5430 • Telex 171-110

1983 JDR MICRODEVICES, INC.

2114 450 NS 8/\$995

2114 250 NS 8/\$1095

7400

7400	.19	74132	.45
7401	.19	74136	.50
7402	.19	74141	.65
7403	.19	74142	2.95
7404	.19	74143	2.95
7405	.25	74145	.60
7406	.29	74147	1.75
7407	.29	74148	1.20
7408	24	74150	1.35
7409	.19	74151	.55
7410	.19	74152	.65
7411	.25	74153	.55
7412	.30	74154	1.25
7413	.35	74155	.75
7414	.49	74156	.65
7416	.25	74157	.55
7417	.25	74159	1.65
7420	.19	74160	.85
7421	.35	74161	.69
7422	.35	74162	.85
7423	.29	74163	.69
7425	.29	74164	.85
7426	.29	74165	.85
7427	.29	74166	1.00
7428	.45	74167	2.95
7430	.19	74170	1.65
7432	.29	74172	5.95
7433	.45	74173	.75
7437	.29	74174	.89
7438	.29	74175	.89
7440	.19	74176	.89
7442	.49	74177	.75
7443	.65	74178	1.15
7444	.69	74179	1.75
7445	.69	74180	.75
7446	.69	74181	2.25
7447	.69	74182	.75
7448	.69	74184	2.00
7450	.19	74185	2.00
7451	.23	74190	1.15
7453	.23	74191	1.15
7454	.23	74192	.79
7460	.23	74193	.79
7470	.35	74194	.85
7472	.29	74195	.85
7473	.34	74196	.79
7474	.33	74197	.75
7475	.45	74198	1.35
7476	.35	74199	1.35
7480	.59	74221	1.35
7481	1.10	74246	1.35
7482	.95	74247	1.25
7483	.50	74248	1.85
7485	.59	74249	1.95
7486	.35	74251	.75
7489	2.15	74259	2.25
7490	.35	74265	1.35
7491	.40	74273	1.95
7492	.50	74276	1.25
7493	.35	74279	.75
7494	.65	74283	2.00
7495	.55	74284	3.75
7496	.70	74285	3.75
7497	2.75	74290	.95
74100	1.75	74293	.75
74107	.30	74298	.85
74109	.45	74351	2.25
74110	.45	74365	.65
74111	.55	74366	.65
74116	1.55	74367	.65
74120	1.20	74368	.65
74121	.29	74376	2.20
74122	.45	74390	1.75
74123	.49	74393	1.35
74125	.45	74425	3.15
74126	.45	74426	.85
74128	.55	74490	2.55

LINEAR

LM301	.34	LM340 (see 7800)	
LM301H	.79	LM348	.99
LM307	.45	LM350K	4.95
LM308	.69	LM350T	4.60
LM308H	1.15	LM358	.69
LM309H	1.95	LM359	1.79
LM309H	1.25	LM376	3.75
LM310	1.75	LM377	1.95
LM311	.64	LM378	2.50
LM311H	.89	LM379	4.50
LM312H	1.75	LM380	.89
LM317K	3.95	LM380N-B	1.10
LM317T	1.19	LM381	1.60
LM318	1.49	LM382	1.60
LM318H	1.59	LM383	1.95
LM319H	1.90	LM384	1.95
LM319H	1.25	LM386	.89
LM320 (see 7900)		LM387	1.40
LM322	1.65	LM389	1.35
LM323K	4.95	LM390	1.95
LM324	.59	LM392	.69
LM329	.65	LM394H	4.60
LM331	3.95	LM399H	5.00
LM334	1.19	NE531	2.95
LM335	1.40	NE555	.34
LM336	1.75	NE556	.65
LM337K	3.95	NE558	1.50
LM337T	1.95	NE561	24.95
LM338K	6.95	NE564	2.95
LM339	.99	LM565	.99

LM566	1.49	LM1800	2.37
LM567	.89	LM1812	8.25
NE570	3.95	LM1830	3.50
NE571	2.95	LM1871	5.49
NE592	2.75	LM1872	5.49
LM709	.59	LM1877	3.25
LM710	.75	LM1889	1.95
LM711	.79	LM1896	1.75
LM723	.49	ULN2003	2.49
LM723H	.55	LM2877	2.05
LM733	.98	LM2878	2.25
LM741	.35	LM2900	.85
LM741N-14	.35	LM2901	1.00
LM741H	.40	LM3900	.59
LM747	.69	LM3905	1.25
LM748	.59	LM3909	.98
LM1014	1.19	LM3911	2.25
LM1303	1.95	LM3914	3.95
LM1310	1.49	LM3915	3.95
MC1330	1.69	LM3916	3.95
MC1349	1.89	MC4024	3.95
MC1350	1.19	MC4044	4.50
MC1358	1.69	RC4136	1.25
MC1372	6.95	RC4151	3.95
LM1414	1.59	LM4250	1.75
LM1458	.59	LM4500	3.25
LM1488	.69	RC4558	.69
LM1489	.69	LM13080	1.29
LM1496	.85	LM13600	1.49
LM1558H	3.10	LM13700	1.49

H = TO-5 CAN T = TO-220 K = TO-3

RCA

CA 3023	2.75	CA 3082	1.65
CA 3039	1.29	CA 3083	1.55
CA 3046	1.25	CA 3086	.80
CA 3059	2.90	CA 3089	2.99
CA 3060	2.90	CA 3096	3.49
CA 3065	1.75	CA 3130	1.30
CA 3080	1.10	CA 3140	1.15
CA 3081	1.65	CA 3146	1.85
		CA 3160	1.19

TI

TL494	4.20	75365	1.95
TL496	1.65	75450	.59
TL497	3.25	75451	.39
75107	1.49	75452	.39
75110	1.95	75453	.39
75150	1.95	75454	.39
75154	1.95	75491	.79
75188	1.25	75492	.79
75189	1.25	75493	.89
75494	.89		

BI FET

TL071	.79	TL084	2.19
TL072	1.19	LF347	2.19
TL074	2.19	LF351	.60
TL081	.79	LF353	1.00
TL082	1.19	LF355	1.10
TL083	1.19	LF356	1.10
LF357	1.40		

74S00

74S00	.32	74S163	1.95
74S02	.35	74S168	3.95
74S03	.35	74S169	3.95
74S04	.35	74S174	.95
74S05	.35	74S175	.95
74S08	.35	74S181	3.95
74S09	.40	74S182	2.95
74S10	.35	74S188	1.95
74S11	.35	74S189	6.95
74S15	.35	74S194	1.49
74S20	.35	74S195	1.49
74S22	.35	74S196	1.49
74S30	.35	74S197	1.49
74S32	.40	74S201	6.95
74S37	.88	74S225	7.95
74S38	.85	74S240	2.20
74S40	.35	74S241	2.20
74S51	.35	74S244	2.20
74S64	.40	74S251	.95
74S65	.40	74S253	.95
74S74	.50	74S257	.95
74S85	1.99	74S258	.95
74S86	.50	74S260	.79
74S112	.50	74S274	19.95
74S113	.50	74S275	19.95
74S114	.55	74S280	1.95
74S124	2.75	74S287	1.90
74S132	1.24	74S288	1.90
74S133	.45	74S289	6.89
74S134	.50	74S301	6.95
74S135	.89	74S373	2.45
74S138	.85	74S374	2.45
74S139	.85	74S381	7.95
74S140	.55	74S387	1.95
74S151	.95	74S412	2.98
74S153	.95	74S471	4.95
74S157	.95	74S472	4.95
74S158	.95	74S474	4.95
74S161	1.95	74S482	15.25
74S162	1.95	74S570	2.95
		74S571	2.95

INTERFACE

8T26	1.59
8T28	1.89
8T95	.89
8T96	.89
8T97	.89
8T98	.89
DM8131	2.95
DP8304	2.29
DS8835	1.99
DS8836	.99

MISC.

TM599532	29.95
ULN2003	2.49
3242	7.95
3341	4.95
MC3470	4.95
MC3480	9.00
11C90	13.95
95H90	7.95
2513-001 LP	9.95
2513-002 LOW	9.95

VOLTAGE REGULATORS

7805T	.75	7905T	.85
78M05C	.35	7908T	.85
7808T	.75	7912T	.85
7812T	.75	7915T	.85
7815T	.75	7924T	.85
7824T	.75	7905K	1.49
7805K	1.39	7912K	1.49
7812K	1.39	7915K	1.49
7815K	1.39	7924K	1.49
7824K	1.39	79L05	.79
78L05	.69	79L12	.79
78L12	.69	79L15	.79
78L15	.69	LM323K	4.95
78H05K	9.95	UA78540	1.95
78H12K	9.95		

C, T = TO-220 K = TO-3
L = TO-92

IF YOU CAN FIND A PRICE LOWER ELSEWHERE, LET US KNOW AND WE WILL MEET OR BEAT THEIR PRICE! (SEE TERMS BELOW)

- * Computer managed Inventory — virtually no back orders!
- * Very competitive prices!
- * Friendly staff!
- * Fast service — most orders shipped within 24 hours!

CLOCK CIRCUITS

MM5314	4.95
MM5369	3.95
MM5375	4.95
MM58167	8.95
MM58174	11.95
MSM5832	6.95

INTERSIL

ICL7106	9.95
ICL7107	12.95
ICL7660	2.95
ICL8038	3.95
ICM7207A	5.99
ICM7208	15.95

9000

9316	1.00
9334	2.50
9368	3.95
9401	9.95
9601	.75
9602	1.50
96S02	1.95

EXAR

XR 2206	3.75
XR 2207	3.75
XR 2208	3.75
XR 2211	5.25
XR 2240	3.25

DATA ACQUISITION

ADC0800	15.55	DAC0808	2.95
ADC0804	3.49	DAC1020	8.25
ADC0809	4.49	DAC1022	5.95
ADC0817	9.95	MC1408L6	1.95
DAC0800	4.95	MC1408L8	2.95

SOUND CHIPS

76477	3.95
76489	8.95
AY3-8910	12.95
AY3-8912	12.95
MC3340	1.49

ORDER TOLL FREE ALL MERCHANDISE 100% GUARANTEED

800-538-5000

800-662-6279 (CALIFORNIA RESIDENTS)



CALL US FOR VOLUME QUOTES

2732 32K EPROM

\$495

2764 64K EPROM

\$995

PROMS

Order by National Part	Function	EQUIVALENT PART NUMBERS				Price
		TI	SIG	MIMI	Harris	
74S188	32x8 OC	18SA030	82S23	6330-1	7602	1.95
74S287	256x4 TS	24S10	82S129	6301-1	7611	1.90
74S288	32x8 TC	18S030	82S123	6331-1	7603	1.90
74S387	256x4 OC	24SA10	82S126	6300-1	7610	1.95
74S471	256x8 TS	28L22		6309-1		4.95
74S472	512x8 TS	28S42	82S147	6349-1	7649	4.95
74S473	512x8 OC	28SA42	82S146	6348	7648	10.95
74S474	512x8 TS	28S46	82S141	6341	7641	4.95
74S475	512x8 TS	28SA46	82S140	6340	7640	12.95
74S478	1Kx8 TS	28S86				19.95
74S570	512x4 OC	27S12	82S130	6305	7620	2.95
74S571	512x4 TS	27S13	82S131	6306-1	7621	2.95
74S572	1Kx4 OC	24SA41	82S136	6352-1	7642	9.95
74S573	1Kx4 TS	24S41	82S137	6353-1	7643	9.95
87S180	1Kx8 OC	28SA86	82S180	6380-1	7680	19.25
87S181	1Kx8 TS	28L86	82S181	6381-1	7681	16.25
87S184	2Kx4 OC	24SA81	82S184		7684	17.20
87S185	2Kx4 TS	24S81	82S185		7685	16.95
87S190	2Kx4 OC	28SA166	82S190		76160	39.95
87S191	2Kx8 TS	28S166	82S191		76161	39.95

WE RESERVE THE RIGHT TO SUBSTITUTE MANUFACTURER

ORDER 800-538-5000
TOLL FREE 800-662-6279
 (CALIFORNIA RESIDENTS)

CAPACITORS

TANTALUM								DISC					
6V	10V	15V	20V	25V	35V	50V		10pF	50V	.05	470	50V	.05
.22uf													
.27													
.33													
.47			.35										
.68													
1.0			.40	.40	.45	.45							
1.5													
1.8													
2.2		.35	.40	.45		.65	.85						
2.7		.40	.45				.90						
3.3		.45	.50	.55	.60	.65	.90						
3.9		.45											
4.7	.45	.55		.60	.65	.85	.90						
6.8		.70											
8.2													
10	.55	.65	.80	.85	.90	1.00							
12	.65		.85	.90									
15	.75	.85	.90										
18			1.25										
22		1.00	1.35										
27			2.25										
39		1.50											
47	1.35												
56	1.75												
100			3.25										
270	3.75												

MONOLITHIC

.1uf-mono	50V	.18	.47uf-mono	50V	.25
-----------	-----	-----	------------	-----	-----

ELECTROLYTIC

RADIAL		AXIAL			
.47uf	50V	.14	1uf	50V	.14
1	25V	.14	4.7	16V	.14
2.2	35V	.15	10	16V	.14
4.7	50V	.15	10	50V	.16
10	50V	.15	22	16V	.14
47	35V	.18	47	50V	.20
100	16V	.18	100	15V	.20
220	35V	.20	100	35V	.25
470	25V	.30	150	25V	.25
2200	16V	.60	220	25V	.30
			330	16V	.40
			500	16V	.42
			1000	16V	.60
			1500	16V	.70
			6000	16V	.85

COMPUTER GRADE

26,000uf	30V	3.95
----------	-----	------

OPTO-ISOLATORS

4N26	1.00	MCA-7	4.25
4N27	1.10	MCA-255	1.75
4N28	.69	IL-1	1.25
4N33	1.75	ILA-30	1.25
4N35	1.25	ILQ-74	2.75
4N37	1.25	H11C5	1.25
MCT-2	1.00	TIL-111	1.00
MCT-6	1.50	TIL-113	1.75

FEDERAL EXPRESS SERVICES AVAILABLE

TRANSISTORS

2N918	.50	MPS3706	.15
MPS918	.25	2N3772	1.85
2N2102	.75	2N3903	.25
2N2218	.50	2N3904	.10
2N2218A	.50	2N3906	.10
2N2219	.50	2N4122	.25
2N2219A	.50	2N4123	.25
2N2222	.25	2N4249	.25
PN2222	.10	2N4304	.75
MPS2369	.25	2N4401	.25
2N2484	.25	2N4402	.25
2N2905	.50	2N4403	.25
2N2907	.25	2N4857	1.00
PN2907	.125	PN4916	.25
2N3055	.79	2N5086	.25
3055T	.69	PN5129	.25
2N3393	.30	PN5139	.25
2N3414	.25	2N5209	.25
2N3563	.40	2N6028	.35
2N3565	.40	2N6043	1.75
PN3565	.25	2N6045	1.75
MPS3638	.25	MPS-A05	.25
MPS3640	.25	MPS-A06	.25
PN3643	.25	MPS-A55	.25
PN3644	.25	TIP29	.65
MPS3704	.15	TIP31	.75
		TIP32	.79

IC SOCKETS

1-99	100
8 pin ST	.13 .11
14 pin ST	.15 .12
16 pin ST	.17 .13
18 pin ST	.20 .18
20 pin ST	.29 .27
22 pin ST	.30 .27
24 pin ST	.30 .27
28 pin ST	.40 .32
40 pin ST	.49 .39
64 pin ST	4.25 call
ST = SOLDER TAIL	
8 pin WW	.59 .49
14 pin WW	.69 .52
16 pin WW	.69 .58
18 pin WW	.99 .90
20 pin WW	1.09 .98
22 pin WW	1.39 1.28
24 pin WW	1.49 1.35
28 pin WW	1.69 1.49
40 pin WW	1.99 1.80
WW = WIREWRAP	
16 pin ZIF	6.75 call
24 pin ZIF	9.95 call
28 pin ZIF	10.95 call
ZIF = TEXT TOOL	
(Zero Insertion Force)	



LED LAMPS

1-99	100-up
Jumbo Red	.10 .09
Jumbo Green	.18 .15
Jumbo Yellow	.18 .15

BYPASS CAPS

.01 UF DISC	100/6.00
.1 UF DISC	100/8.00
.1 UF MONOLITHIC	100/15.00

LED DISPLAYS

HP 5082-7760	.6"	CC	1.29
MAN 72	.3"	CA	.99
MAN 74	.3"	CC	.99
FND-357 (359)	.375"	CC	1.25
FND-500 (503)	.5"	CC	1.49
FND-507 (510)	.5"	CA	1.49

RESISTORS

1/4 WATT 5% CARBON FILM ALL STANDARD VALUES
 FROM 1 OHM TO 10 MEG OHM
 50 PCS. SAME VALUE .025
 100 PCS. SAME VALUE .02
 1000 PCS. SAME VALUE .015

MUFFIN FANS NEW UN-USED

4.68" Square	14.95
3.125" Square	14.95

HEAT SINKS

TO-3 style	.95
TO-220 style	.35

SWITCHES

SPDT mini-toggle	1.25
DPDT mini-toggle	1.50
SPST mini-pushbutton	.39

VISIT OUR RETAIL STORE — NEW HOURS —
 M-W-F, 9-5
 T-Th., 9-9 Sat. 11-3

PLEASE USE YOUR CUSTOMER NUMBER WHEN ORDERING

TERMS For shipping include \$2 for UPS Ground or \$3 for UPS Blue Label Air. Items over 5 pounds require additional shipping charges. Foreign orders include sufficient amount for shipping. There is a \$10 minimum order. Bay Area and Los Angeles Counties add 6 1/2% Sales Tax. Other California residents add 6% Sales Tax. We reserve the right to substitute manufacturer. Not responsible for typographical errors. Prices are subject to change without notice. We will match or beat any competitor's price provided it is not below our cost.

JDR Microdevices
 1224 S. Bascom Avenue
 San Jose, CA 95128
 800-538-5000 • 800-662-6279 (CA)
 (408) 995-5430 • Telex 171-110

1983 JDR MICRODEVICES, INC

2716

16K EPROMS

\$395 EACH

2732

32K EPROMS

\$495 EACH

MICROCOMPUTER HARDWARE HANDBOOK FROM ELCOMP — \$14.95
Over 800 pages of manufacturers data sheets on most commonly used IC's.
Includes:
* TTL — 74/74LS and 74F
* CMOS
* Voltage Regulators
* Memory — RAM, ROM, EPROM
* CPU's — 6800, 6500, Z80, 8080, 8085, 8086/8
* MPU support & interface — 6800, 6500, Z80, 8200, etc.

DISK DRIVES TANDON
TM100-1 5 1/4" (FOR IBM) SS/DD **229.00**
TM100-2 5 1/4" (FOR IBM) DS/DD **295.00**
SHUGART
SA 400L 5 1/4" (40 TRACK) SS/DD **199.95**
SA 400 5 1/4" (35 TRACK) SS/DD **189.95**
PERTEC
FD-200 5 1/4" SS/DD **179.95**
FD-250 5 1/4" DS/DD **199.95**
MPI
MP-52 5 1/4" (FOR IBM) DS/DD **295.00**
 NOTE: Please include sufficient amount for shipping on above items.

8" DRIVE SALE
FD100-8 **\$189**
 SHUGART 801 EQUIVALENT
 SS/DD 10 FOR \$175 EA.
FD200-8 **\$239**
 SHUGART 851 EQUIVALENT
 DS/DD 10 FOR \$220 EA.

BEST SELLING BOOKS
OSBORNE/MC GRAW-HILL
 Apple II User's Guide **16.95**
 CRT Controller's Handbook **9.95**
 68000 Assembly Language
 Programming **16.99**
 CBASIC User Guide **15.00**
SYBEX
 Your First Computer **8.95**
 The CP/M Handbook **14.95**
 The PASCAL Handbook **18.95**
 Microprocessor Interfacing
 Techniques **17.95**

CABINETS FOR 5 1/4" DISK DRIVES
CABINET #1 \$29.95
 * DIMENSIONS 8 5/8 x 5 15/16 x 3 15/16"
 * COLOR MATCHES APPLE
 * FITS STANDARD 5 1/4" DRIVES, INCL. SHUGART
 * INCLUDES MOUNTING HARDWARE AND FEET
CABINET #2 \$79.00
 * COMPLETE WITH POWER SUPPLY, SWITCH, LINE CORD, FUSE & STANDARD POWER CONNECTOR
 * DIMENSIONS: 11 1/2 x 5 3/4 x 3 15/16"
 * +5V @ 1 AMP, +12V @ 1.5 AMP
 * FITS STANDARD 5 1/4" DRIVES
 * PLEASE SPECIFY GRAY OR TAN

EDGE-CARD CONNECTORS
 S-100 ST **3.95**
 S-100 WW **4.95**
 72 pin ST **6.95**
 72 pin WW **7.95**
 50 pin ST **4.95**
 44 pin ST **2.95**
 44 pin WW **4.95**
 44 pin SE **3.95**

TRANSFORMERS
FRAME STYLE
 12.6VAC 2amp **4.95**
 12.6VAC CT 2amp **5.95**
 12.6VAC CT 4amp **7.95**
 12.6VAC CT 8amp **10.95**
 25.2VAC CT 2amp **7.95**
PLUG CASE STYLE
 12VAC 250ma **3.95**
 12VAC 500ma **4.95**
 12VAC 1amp **5.95**
 12VAC 2amp **6.95**
DC ADAPTER
 6, 9, 12 VDC selectable with universal adapter **8.95**
 NOTE: Please include sufficient amount for shipping on above items.

DIP CONNECTORS

DESCRIPTION	HIGH RELIABILITY TOOLED ST IC SOCKETS	COMPONENT CARRIERS (DIP HEADERS)	RIBBON CABLE DIP PLUGS (IDC)
ORDER BY	AUGATxx-ST	ICCxx	IDPxx
CONTACTS 8	.99	.65	
14	.99	.75	1.45
16	.99	.85	1.65
18	1.69	1.00	
20	1.89	1.25	
22	1.89	1.25	
24	1.99	1.35	2.50
28	2.49	1.50	
40	2.99	2.10	4.15

For order instructions see "IDC Connectors" below.

POWER SUPPLY MODEL 2 \$39.95
 MOUNTED ON PC BOARD
 MANUFACTURED BY CONVER
 +5 VOLT 4 AMP
 ±12 VOLT 1 AMP
 NOTE: Please include sufficient amount for shipping on above items.



RIBBON CABLE

CONTACTS	SINGLE COLOR		COLOR CODED	
	1'	10'	1'	10'
10	.50	4.40	.83	7.30
16	.55	4.80	1.00	8.80
20	.65	5.70	1.25	11.00
25	.75	6.60	1.32	11.60
26	.75	6.60	1.32	11.60
34	.98	8.60	1.65	14.50
40	1.32	11.60	1.92	16.80
50	1.38	12.10	2.50	22.00

D-SUBMINIATURE

DESCRIPTION	SOLDER CUP		RIGHT ANGLE PC SOLDER		IDC RIBBON CABLE		HOODS	
	MALE	FEMALE	MALE	FEMALE	MALE	FEMALE	BLACK HOOD-B	GREY HOOD
ORDER BY	DBxxP	DBxxS	DBxxPR	DBxxSR	IDBxxP	IDBxxS		
CONTACTS 9	2.08	2.66	1.65	2.18	3.37	3.69	---	1.60
15	2.69	3.63	2.20	3.03	4.70	5.13	---	1.60
25	2.50	3.25	3.00	4.42	6.23	6.84	1.25	1.25
37	4.80	7.11	4.83	6.19	9.22	10.08	---	2.95
50	6.06	9.24	---	---	---	---	---	3.50

For order instructions see "IDC Connectors" below.
CALL FOR MOUNTING HARDWARE

CENTRONICS
 IDCEN36 Ribbon Cable 36 Pin Male **8.95**
 CEN36 Solder Cup 36 Pin Male **7.95**

IDC CONNECTORS

DESCRIPTION	SOLDER HEADER	RIGHT ANGLE SOLDER HEADER	WW HEADER	RIGHT ANGLE WW HEADER	RIBBON HEADER SOCKET	RIBBON HEADER	RIBBON EDGE CARD
ORDER BY	IDHxxS	IDHxxSR	IDHxxW	IDHxxWR	IDSxx	IDMxx	IDExx
CONTACTS 10	.82	.85	1.86	2.05	1.15	---	2.25
20	1.29	1.35	2.98	3.28	1.86	5.50	2.36
26	1.68	1.76	3.84	4.22	2.43	6.25	2.65
34	2.20	2.31	4.50	4.45	3.15	7.00	3.25
40	2.58	2.72	5.28	4.80	3.73	7.50	3.80
50	3.24	3.39	6.63	7.30	4.65	8.50	4.74

ORDERING INSTRUCTIONS: Insert the number of contacts in the position marked "xx" of the "order by" part number listed. Example: A 10 pin right angle solder style header would be IDH10SR.

FOR APPLE COMPUTER USERS

FD-35 DISK DRIVE

- ★ Direct Replacement for Apple Disk II
- ★ Compatible with Apple Controller or other Apple compatible controllers
- ★ Specially designed electronics with **low power consumption**
- ★ DOS 3.3 and 3.2 compatible
- ★ Owner's Manual and Warranty Card included

NOW
WITH ONE YEAR \$229⁹⁵
WARRANTY
CONTROLLER CARD \$89.95

VIEWMAX-80

- A Full Function
 80 Column Card for Apple II*
 * Soft Video Switch * Shift Key Support
2 YEAR WARRANTY

NOW ONLY \$189⁹⁵

5 1/4" DISKETTES VERBATIM DATALIFE

SS/DD SOFT SECTOR **29.95**
 SS/DD 10 SECTOR HEAD **29.95**

NASHUA

SS/DD SOFT SECTOR
 WITH HUB RING **\$19⁹⁵**
BEST BUY

Ask about our full
 line of Nashua diskettes

THOUSANDS SOLD JDR 16K RAMCARD

- ★ Expand your 48K Apple to 64K
- ★ Fully compatible with Apple Language System — Use in place of Apple Language card
- ★ Provides extra memory for Visicalc™
- ★ Run PASCAL, FORTRAN, Integer Basic with appropriate software
- ★ Highest quality card features: gold edge connector, sockets for all IC's

WITH 2 YEAR WARRANTY

ASSEMBLED & TESTED
 WITH WARRANTY **\$44⁹⁵**

KIT — INCLUDES ALL
 PARTS & INSTRUCTIONS **\$40⁹⁵**

BARE PC CARD
 WITH INSTRUCTIONS **\$14⁹⁵**

APPLE COMPATIBLE POWER SUPPLY \$99.95

- ★ Compact Switching Design
- ★ All Outputs regulated
- ★ Short Circuit and Overload Protection
- ★ Complete with Apple-type plug-in power cord
- ★ Apple Compatible — Yet higher output allows more disk drives and cards without overheating
- ★ +5V @ .5A, +12V @ 3A, -5V @ .5A, -12V @ .5A
- ★ Shielded enclosure: 10 3/4" x 3 1/2" x 2 1/8"

NEW IMPROVED JDR COOLING FAN

- ★ Easy modification — no modification of Apple required
- ★ Eliminates overheating problems
- ★ Switch on front controls fan, Apple, and extra outlet
- ★ Rotron whisper fan is the quietest, most reliable on the market

**NOW WITH SURGE
 SUPPRESSION
 \$69.95**

**WITHOUT SURGE
 SUPPRESSION \$59.95**

MONITORS MONOCHROME

NEC JB1201M - 20 MHZ GREEN **\$169**
 ZENITH ZUM-121 - 15 MHZ GREEN **\$99**
 TAXAN 18 MHZ AMBER **\$139**
COLOR
 AMDEK COLOR I - COMPOSITE **\$335**
NO C.O.D. ORDERS PLEASE

ORDER TOLL FREE
800-538-5000
800-662-6279
 (CALIFORNIA RESIDENTS)

ACCESSORIES FOR APPLE II & IIE

ALL WITH 1 YEAR WARRANTY BY



PRINTERLINK CENTRONICS PARALLEL INTERFACE

- ★ Simple to use — No configuring required
- ★ Use with any centronics printer — EPSON, OKIDATA, etc.
- ★ Includes Cable & Manual

\$59⁰⁰

MESSENGER SERIAL INTERFACE

- ★ Connects to any RS-232 serial device
- ★ 8 switch selectable drivers for printers, terminals and modems
- ★ Includes Cable & Manual

\$99⁰⁰

TIMELINK REAL TIME CLOCK

- ★ Applications in file management, word processing, communications, etc.
- ★ Exclusive Alarm Clock feature
- ★ Battery recharges automatically

\$84⁰⁰

NEW BUFFERLINK ADD-ON PRINTER BUFFER

- ★ Saves Time — No more waiting for printed output
- ★ Connects easily to any parallel interface
- ★ Expandable from 16K to 64K

\$139⁰⁰ (16K)

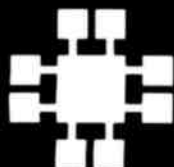

JDR Microdevices

1224 S. Bascom Ave. • San Jose, CA 95128
 (408) 995-5430 • Telex 171-110

1983 JDR MICRODEVICES, INC.

VISIT OUR RETAIL STORE

HOURS: M-W-F, 9-5 T-Th., 9-9 Sat. 11-3

PLEASE USE YOUR CUSTOMER NUMBER WHEN ORDERING
 TERMS: For shipping include \$2 for UPS Ground or \$3 for UPS Blue Label Air. Items over 5 pounds require additional shipping charges. Foreign orders, include sufficient amount for shipping. There is a \$10 minimum order. Bay Area and Los Angeles Counties add 6 1/2% Sales Tax. Other California residents add 6% Sales Tax. We reserve the right to substitute manufacturer. Not responsible for typographical errors. Prices are subject to change without notice. We will match or beat any competitor's price provided it is not below our cost.

Unclassified Ads

WANTED: Nonprofit organization of volunteer professionals devoted to rehabilitation research and community service for persons with hearing or vision impairments needs microcomputer system suitable for limited word processing and telecommunications applications: several modems, two terminals, and at least one fast printer. Donations are fully tax-exempt. J. Whitlock, New England Institute of Applied Biophysics, 59 North Ashland St., Worcester, MA 01609. (617) 798-8707.

WANTED: The Vietnam Veterans' Resocialization Program is seeking a tax-deductible donation of an Apple II Plus with two disk drives. Our veterans' self-help organization needs to computerize the database, implement word processing, and upgrade the accounting and budget processes. Our references and IRS information on request. Bill Kittredge, Vietnam Veterans' Resocialization Program, Box 1319, Springfield, OR 97477. (503) 687-6918.

WANTED: Health service group is seeking a tax-deductible donation of a TRS-80 Model I or III hardware and software. Thomas G. Lareau, Edgar Area Medical Center, 107 3rd Ave., Edgar, WI 54426. (715) 352-2302.

WANTED: Nonprofit early childhood program, interested in exposing the children to a tool of the present and future, is seeking an Apple computer. Sharon Swain, Childhood Development Center, 1229 West 2nd, McMinnville, OR 97128. (503) 472-1009.

WANTED: Nonprofit community organization seeks tax-deductible personal computer for community programs such as research, record keeping (for food co-op), tutoring, Neighborhood Watch, fund raising, and grassroots organizing. Brad Fields, Citizens Action Research Project, 730 East 7th St., National City, CA 92050. (619) 474-8569.

WANTED: Minicomputer system for nonprofit organization. Any donation would be fully tax-deductible. Roy Tanenbaum, 160 Westwood Dr., Park Forest, IL 60466. (312) 747-9513.

WANTED: Tax-deductible donation of a ZX81-compatible computer for Boy Scouts of America, Order of the Arrow organization. We need it to keep financial records and mailing lists of members. Will send receipt and pay shipping costs. Also, same needed for a computer science student in high school. Roger Hull, Rt. 4, Box 120, Mariow, OK 73055. (405) 658-5175 after 4 p.m. CT.

WANTED: Portuguese graduate student with experience in 2D and 3D CAD, IBM, CDC, PRIME, and FORTRAN seeks working holidays in the U.S. during summer '83. Will bring my Sinclair Spectrum with 80K, drive, FORTH, PASCAL, BASIC Compiler, and Z80 ASSD/IS. My interest is in music projects. Tony Pereira, Amsterdamse Veerkade-41 F, 2512 AH The Hague, Holland.

WANTED: I need a copy of Douglas Maurer's two-part article: Processing Algebraic Expressions, Parts 1 and 2. The articles appeared consecutively in BYTE February and March 1976. I'll pay costs. Ronald Malpeli, 142-02 Franklin Ave., Flushing, NY 11355. (212) 762-2249.

WANTED: Apple II users who are interested in communicating about Assembler programs and/or trying to change existing ones. Armin Herold, Bahnwaldstr. 21f, 79110 Neu-Ulm B, West Germany.

FOR SALE: Texas Instruments Silent 745 used terminals at less than half price. Russell White, (212) 997-6075.

WANTED: Accountant seeks communication with user groups in the Great Lakes area for the TRS-80 Model I business computer. Michael Gouthro, Complete Bookkeeping Service, Box 8130, Dundas, Ontario L9H 5E7, Canada.

FOR SALE: KGS-80 and cables for Apple and TRS-80 Model I. Adapts your Selectric to work as a letter-quality printer. Original cost \$595. Like-new condition: \$300. R. Markman, 638 Meadow Court, Westbury, NY 11590.

FOR SALE: TRS-80 Model I with Level II BASIC and 16K RAM, Editor/Assembler and Debug along with assorted programs, manuals, and graphics texts: best offer. Also, brand new Line Printer VII with parallel-port cable, paper, and manuals: \$400. Mark Marine, 4717 Mermaid Blvd., Wilmington, DE 19808. (302) 239-0905.

FOR SALE: 128K Apple II with green screen monitor, external disk drive, and MX-80 printer with Graftrax-80. Software includes Apple Business BASIC, Apple III Visicalc, Apple II Emulation, and many utilities. About six months old; perfect condition: \$3900. Randy Murrish, 2919 Ave. E. Kearney, NE 68847.

FOR SALE: New Intel 86/12A single-board computer. System includes 8086 processor, system clock, 32K bytes of dual-port RAM, Multibus arbitration logic, vectored interrupt controller, two programmable timers, 24 programmable I/O lines, and a USART. Lists at \$1950, will sell for \$700. F.J. Posivak, 68 Hickory Dr., Quakertown, PA 18951. (215) 536-7587.

FOR SALE: TRS-80 Model I with 48K includes processor with lowercase adapter, expansion interface, one disk drive, monitor, and over 8000 in software. Excellent condition. Software includes word processors, business programs, utilities, and games. Asking \$1200 or will trade for a TRS-80 Color Computer with monitor, disk drive, and Flex DOS. Will Carter, 4407 Griffin St., Moss Point, MS 39563. (601) 475-6855.

WANTED: Apple software to swap. Will trade a large library of programs for anything from utilities to arcade games. Send a list of your programs and I will send you mine. Please include a SASE. Gary Derksen, 926 20 A Ave., Coaldale, Alberta T0K 0L0, Canada. (403) 345-4697.

WANTED: Computer listings for TRS-80 Model I Level II 16K RAM or Apple II Plus 3.3 DOS. Any type of program will do: games, graphics, or personal. I will send a list of same in return. Matt Jenkins, 220 Westwood Dr., Thompson, Manitoba RBN 0E9, Canada.

NEEDED: I am interested in corresponding with Morrow Micro-Decision users, groups, clubs, or newsletters. Also, will pay for schematics for this machine. Stan Ahalt, 102-B Victoria Lane, Clemson, SC 29631. (803) 656-3376, 654-2748 evenings.

FOR SALE: Trendcom 200 (Apple Slientype) thermal printer. Recent factory overhaul. With several rolls of paper, no cable or interface. Send SASE for sample output. \$295 delivered anywhere in continental USA. M. Weiss, 7656 Daniel Dr., New Orleans, LA 70127.

FOR SALE: Radio Shack Line Printer VII, a few months old, perfect condition, high-density graphic, prints 40 or 80 uppercase and lowercase, uses standard fanfold paper, and parallel and serial interfaces: \$275 or best offer. Peter Lee, 100 LaSalle Court, New Orleans, LA 70118. (504) 865-2447 after 5 p.m.

WANTED: A Timex/Sinclair user group would like to hear from other owners or user groups willing to trade or swap software and information. Send 50¢ (stamps ok) and SASE for details. North Bay Computing, 500 Eastwood Dr., Petaluma, CA 94952.

FOR SALE: Clpher Microstreamer tape drive, 1/2-inch, 1600-bpi, PE format. Uses standard IBM-compatible ree-type magnetic tapes. Alloy Engineering intelligent tape-drive controller board for S-100 bus. Software utilities which operate under CP/M 2.2+ or MP/M 1.1+. New condition: \$4400 or best offer. R. Luebbe, POB 6206, Falls Church, VA 22046. (703) 573-3849.

FOR SALE: Assembled S-100 board with documentation: SSM Music Synthesizer (IMUS-X1): \$150. SSM Video Interface (VBI1B): \$100. Two SSM BK static RAM (MB6A): \$50 each. SSM 8080 processor board with 2K EPROM monitor: \$100. Itasca Audio BK static RAM: \$50. 10-slot motherboard with power supply, card cage, and chassis (without cover): \$110. 22-slot motherboard with chassis (without cover): \$100. David Gee, 1624-70th Ave., Oakland, CA 94621. (415) 562-5098.

FOR SALE: 13-inch color monitor, \$269. Computer Interface for VIC-20 or 64 to a video cassette recorder to store 50 megabytes per tape: \$99. Dennis Hallingstad, 318 S. K., Sparta, WI 54656.

FOR SALE: Heath H-14 printer with manuals: \$250. GE TN-300 printer with RS-232C interface: \$100. Hazeltine/GE TN-1200 printer with parallel interface: \$200. James Schnitzmeyer, 606 South Main, Box 64, Albany, IL 61230. (309) 887-5106.

FOR SALE: Grappier+ interface card, new, unused, and tested. Has parallel interface cable, connectors, instruction book, and warranty: in original package: \$99. Larry Solomon, 5122 North Tortolita Rd., Tucson, AZ 85745. (602) 743-7924.

FOR SALE: Compuprism S-100 color-graphics board, 144h by 192v pixel plane with each pixel independently programmed in eight colors. Assembled from bare board, runs just fine; selling due to incompatibility with my memory board. Also, I want a Microangelo graphics board MAS20. David Bodette, 202 Nuclear Science Center, Gainesville, FL 32611. (904) 392-3880 or 378-4313.

FOR SALE: IMSAI 8080A with 48K RAM, video board, 4 parallel I/O ports, single drive, keyboard, North Star DOS, several disks. All in working order: \$375 FOB here. Harry Mayer, 10 Woodmere, Skaneateles, NY 13152. (315) 685-3310.

FOR TRADE: Want to swap programs for Apple II Plus or Franklin 1000 computer. Send your list of programs or games and I'll send mine. Marv Alpert, 4 Harwood Dr. W, Glen Cove, NY 11542.

FOR SALE: Cromemco Z-2D, 64K RAM memory (four 16K), dual Wanco drives, Beehive 8100 terminal, Centronics 703 printer with VFU, and software. All for \$4500. A. Smart, 2036 Colony St. #7, Mountain View, CA 94043. (415) 968-0159.

FOR SALE: Mountain computer 100,000 day clock for S-100 bus. 100ms minimum interval. Battery backup. Unused: \$125. D. Russell, 12 Winchester, Southboro, MA 01772. (617) 485-7516.

FOR SALE: DS-65 Video Digitizer for the Apple II. Sells new for around \$650; will sell for \$500 or best offer. Will also consider trade for text-to-speech synthesizer with programmable pitch and inflection. Brian Prigge, 523 W/ison Ave. SE, St. Cloud, MN 56301. (612) 252-1615.

FOR SALE: Commodore VIC-20 computer with data cassette recorder. Will also include Super Expander and two cartridge games (Gorf and Radar Rat Race). Will accept all reasonable offers. Both manuals included. Enrico Vaccaro, 716 East 81 St., Brooklyn, NY 11236.

WANTED: Low-cost (\$5 to \$75) new or used microcomputers (VIC-20, TI-99/2A, AIM-65, Venture, etc.) or memory devices (cheap disk drive, stringy floppy, memory-expansion modules for TI-99/2A, VIC-20, Timex 1000, Sinclair ZX81, etc.) for my experiments with videodisc players and optical bar-code reader wands. David Lyons, 1118 South Clinton #M, Oak Park, IL 60304.

FOR SALE: Epson Graftrax 80 graphics ROMS set, bit-plot graphics capability for Epson MX-80 printers, includes original manual: \$35. Also, Radio Shack TRS-80 Model I, Level II BASIC, 48K memory with lowercase modification: \$800. Kenneth Hom, 13B Magnolia Lane, Eatontown, NJ 07724. (201) 542-1500 ext. 292.

FOR SALE: Enhance your Apple II with Apple IIe features: lowercase, auto-repeat keys, and more. Videx Keyboard Enhancer II: \$99 (retail \$149). Videx Videoterm Board: \$199 (retail \$345). Offers 80-column display, Videx Soft Video Switch: \$19 (retail \$35). 16K RAM Board: \$49 (retail \$195). Excellent condition. Original cartons and documentation. Bob Britton, 6111 Jadedcrest Court, Spring, TX 77379. (713) 376-7525.

WANTED: Apple users who want to start a software user's group. Interested persons may send me your disk of copyable material to copy. I will then send your disk back with programs I have acquired from other users (specify interest). Brett Combs, POB 447, Whitesboro, TX 76273.

FOR SALE: Diablo 1640 KSR (keyboard send/receive) letter-quality, daisy-wheel printing terminals with serial RS-232C interface. Can double as a printer or as a stand-alone terminal. Little use; like-new condition: \$2000 or best offer. Robert Thompson, 214 Basket Rd., Webster, NY 14580. (716) 265-0384.

FOR SALE: Lear-Siegler ADM-42 terminal with 16 function keys, printer port, expanded memory (8 pages). Also, Ven-Tel 212 modem, 300 or 1200 data rate with auto-answer and self-test features. Prices negotiable. Mike Gage, (703) 978-1763.

FOR SALE: SYM-I single-board microcomputer, fully assembled with 28-key dual-function keyboard, 6-digit LED display, 1K RAM expandable on board to 4K, cassette interface, single +5 volt operation, and 6502 microprocessor. \$100 or best offer. Jeff Taragin, (301) 628-8516 days, 764-6091 evenings.

FOR SALE: North Star time-shared multiuser computer system (less terminals and printers), four user 288K plus memory 18-megabyte hard disk. Two double-density double-sided floppy disks. High-performance, low-cost system: \$6000. R. Morrison, POB 188, Cannon Beach, OR 97110. (503) 436-1122.

FOR SALE: TRS-80 Model I, Level II BASIC, 32K RAM. Accessories include disk drive, video monitor, expansion interface, home controller, cassette recorder, and line printer IV with proportional spacing. Also, Scriptit word processing, mailing list. Tiny Pascal, Editor/Assembler, and tons of other software packages. All manuals and documentation \$1500 or best offer. Cliff Brust, 408 West David Rd., Kettering, OH 45429. (513) 667-2431 ext. 2243.

WANTED: Will pay \$7 for an unused set of keyboard command stickers (overlays) as originally issued with the Program Apple PIE word-processor program. Check sent immediately on receipt. Robert Greenwald, POB 401, Wheatley Heights, NY 11798.

FOR SALE: SwTPC 6800 with 4K memory, PERCOM cassette/terminal interface and full documentation: \$150 or best offer. Julius Cassels, RFD 1, Suncook, NH 03275. (603) 736-8179.

WANTED: Used circuit boards from similar models for a ComData Model 933 teletypewriter/plotter terminal. H. E. Fiehler, 4200 East University, Middletown, OH 45042.

UNCLASSIFIED POLICY: Readers who have computer equipment to buy, sell, or trade or who are requesting or giving advice may send a notice to BYTE for inclusion in the Unclassified Ads section. To be considered for publication, an advertisement must be noncommercial (individuals or bona fide computer clubs only), typed double-spaced on plain white paper, contain 75 words or fewer, and include complete name and address. This service is free of charge; notices are printed once only as space permits. Your confirmation of placement is appearance in an issue of BYTE as we engage in no correspondence. Please allow at least three months for your ad to appear. Send your notices to Unclassified Ads, BYTE/McGraw-Hill, POB 372, Hancock, NH 03449.

Unclassified Ads

FOR SALE: Hazeltine Esprit terminal. Perfect condition, no longer needed due to recent computer acquisition: \$500. Also, would like to correspond with Micropolis DOS users, preferably Model II users. Gunnar Seaburg, URH 119 Townsend, 1010 West Illinois, Urbana, IL 61801.

FOR SALE: S-100 Z80 CP/M system, 64K high-speed static memory, 128K electronic disk (semidisk), two double-sided double-density 8-inch disk drives (2.4 megabytes), two serial ports, two parallel ports, CP/M 2.2. Also, word processing, communication, C, and Pascal software. Manuals and disks. A year old; \$1995. Richard Schwartz, 454 26th Ave., San Mateo, CA 94403, (415) 859-5875.

FOR SALE: Ohio Scientific C4P-DF, color video system-DAC, output, 48K RAM 8-inch dual, floppy disks, two joysticks, 1982 factory update, DOS 3.3 manuals, little used. Cost \$3200; will sell for \$2400 or best offer. Robert M. Woldman, 2120 St. Clair Ave., Cleveland, OH 44114, (216) 241-2267.

FOR SALE: Heath H-19 terminal, H-11A computer with 32K memory, two serial one parallel interface cards, 300-bps direct-connect modem, and manuals. Excellent condition; \$1200. M.D. Erdman, 2211 Thornhill Rd., Tifton, GA 31794, (912) 382-9498.

FOR SALE: MSI 6800 computer system, 32K, two serial I/O ports, FD-8 dual 8-inch disk drives, TI-810 printer, LSI ADM-3A terminal, all software and documentation. Software includes BASIC interpreter, BASIC compiler, assembler, editor, and more; \$2800. Mel Woolf, 10808 Midsummer Dr., Reston, VA 22091, (703) 860-1315.

WANTED: To correspond with TRS-80 color computer users who wish to exchange software and information. Joel E. Yingst, 463 Maple St., Annville, PA 17003.

FOR SALE: Tektronix 4051, full memory, documentation, excellent condition; \$3700. David F. Rogers, 817 Holly Dr. E. Rt. 10, Annapolis, MD 21401, (301) 757-5724.

FOR SALE: IBM 5100 portable computer with two cartridge tape drives, IBM 5103 (132-column) printer, over 25 tape cartridges (some new), all manuals, cables, G/L, A/R, P/R, inventory and mail-list software (plus several other business programs). Originally \$15,000, will sell for \$5000 or best offer. Will not sell items separately. Will pay shipping. M. Reardon, 17 Earl Lane, Rothsville, PA 17543, (717) 627-5353 (no collect calls).

FOR SALE: Digital Group equipment: single-density floppy-disk controller board: \$125. Parallel-port board (4 In, 4 out): \$45. Four Ph-Decks with cabinet, controller board, Philmon, and EPROM: \$265. All in good working condition, but I have switched to double density and don't need it. Harold E. Frye, 1551-5th Ave. SW, Rochester, MN 55901.

FOR SALE: Two S-100 8K static-memory boards, 100% functional: \$75 each or both for \$125. For Xerox copies of schematics and description, send 50¢ and SASE. Michael Scott, 2204-3 Arbor Circle, Downers Grove, IL 60515.

FOR SALE: 2708 EPROMs. I have about 275 EPROMs that were removed when equipment was upgraded to 2716. I will sell them at rock-bottom prices. All were working when removed. Perfect for the hobbyist. Make offer for all or part. Rick Matthews, POB 80685, Baton Rouge, LA 70898, (504) 291-0832 evenings and weekends.

FOR SALE: 22-slot TEI S-100 chassis, factory-assembled industrial grade, never used. Will sell or trade for serial printer. Sanders 722 display and keyboard with prints: \$50 or best offer. Philip L. Edelsberg, 4148 West Breese Rd., Lima, OH 45806, (419) 999-5363 evenings or 226-4324 days.

WANTED: Memorex 550 flexible disk drive. James Mantoath, 2351 Interjackin Circle, Cleveland, TN 37311, (615) 479-8015.

FOR SALE: 64K MFP-II home computer totally compatible to the Apple and Franklin Ace. It contains color, graphics, low and high resolution, radio-frequency modulator, etc.; \$399. Abbey A. Perez, 7943 Kenton, Skokie, IL 60076, (312) 677-9118.

FOR SALE: Medical computer books. Computers in Medicine: An Introduction: \$18. Computers in Laboratory Medicine (clinical labs and nuclear medicine): \$34. Microcomputer Programs in Medicine (BASIC program listings for scheduling, billing and graph plotting): \$80. T. Armstrong, Box 874, Center Moriches, NY 11974.

FOR SALE: Mint 48K Apple II motherboard with Applesoft; \$395. 5-Amp power supply; \$85. Money order preferred. V.L. Davenport, 113 Coventry Court, Naperville, IL 60565, (312) 420-1415 evenings and weekends.

FOR EXCHANGE: Commodore 64 programs. Send your list with brief explanation and so will I. Arcade, board and/or adventure games, educational and/or tutorial programs, especially. A partial list of what I have: Rubik's Cube solution, Yahzee, Backgammon, Monopoly, Blackjack, Othello, Break-out, and Firefighter. 5/4-inch floppy disk or tape cassette. Lynn D. Lemer, 7908 Venetian St., Miramar, FL 33023.

WANTED: SD Systems users—I have several 8-inch DS/SD floppy disks, the contents of which I would like read and printed or transferred to a more portable format (such as IBM 3741). The data was written on an SD Systems with Versa-floppy controller. Willing to pay for the services rendered. Bill Sheffer, 253 J Ave., Coronado, CA 92118, (619) 435-8333.

BOMB BYTE's Ongoing Monitor Box

Article #	Page	Article	Author(s)
1	36	Build a Power-Line Carrier-Current Modem	Ciarcia
2	48	The C Language and Models for Systems Programming	Johnson, Kernighan
3	64	A C Language Primer, Part 1: Constructs and Conventions in C	Joyce
4	82	Comparing C Compilers for CP/M-86	Houston
5	110	Five C Compilers for CP/M-80	Kern
6	134	Nine C Compilers for the IBM PC	Phraner
7	172	Managing Software Development with C	Linhart
8	186	The Unix Tutorial Part 1: An Introduction to Features and Facilities	Fiedler
9	212	A Survey of Unix and C Resources	Zintz
10	222	What is a Software Tool?	Thomas
11	243	The Unix C Compiler in a CP/M Environment	Halfant
12	268	Annotated C: A Bibliography of the C Language	Ward
13	286	Chisel Your Code with a Profiler	Leas, Wintz
14	292	A New Shape Subroutine for the Apple	Simoni
15	312	The Debate Goes On	Pournelle
16	331	The IBM PC and the Intel 8087 Coprocessor, Part 1: Overview and Floating-Point Assembly-Language Support	Field
17	386	Curious Coordinates for Computer Graphics	Millikan
18	401	BYTE West Coast: The Future of Software Design	Gates
19	404	The 8086—An Architecture for the Future, Part 3: Instruction Set Continued	Heywood
20	434	User's Column: Epson QX-10, Zenith Z-29, CP/M-68K, and More	Pournelle
21	456	Voice Lab, Part 2: Menu-Driven Routines for Digital Speech Synthesis and Analysis	Hoot
22	477	Help in Apple III Pascal	Evans

May BOMB Winners

Jerry Pournelle's eclectic User's Column, "Uterior Motives, Lobo, Buying Your First Computer, JRT Update," placed first in the May BOMB contest. Jerry will take home the \$100 prize. The second-place award for \$50 goes to Steve Ciarcia for his article, "Build an RS-232C Code-Activated Switch." Rich Malloy, a BYTE technical editor, earned third place for "Little Big Computer," a review of the TRS-80 Model 100 Portable Computer.

Correspondence

Address all editorial correspondence to the editor at BYTE, POB 372, Hancock NH 03449. Unacceptable manuscripts will be returned if accompanied by sufficient first-class postage. Not responsible for lost manuscripts or photos. Opinions expressed by the authors are not necessarily those of BYTE. Entire contents copyright © 1983 by BYTE Publications Inc. All rights reserved. Where necessary, permission is granted by the copyright owner for libraries and others registered with the Copyright Clearance Center (CCC) to photocopy any article herein for the flat fee of \$1.50 per copy of the article or any part thereof. Correspondence and payment should be sent directly to the CCC, 21 Congress St., Salem MA 01970. Specify ISSN 0360-5280/83. \$1.50. Copying done for other than personal or internal reference use without the permission of McGraw-Hill is prohibited. Requests for special permission or bulk orders should be addressed to the publisher. BYTE® is available in microform from University Microfilms International, 300 North Zeeb Rd, Dept. PR, Ann Arbor MI 48106 USA or 18 Bedford Row, Dept. PR, London WC1R 4EJ England.

Reader Service

Inquiry No.	Page No.	Inquiry No.	Page No.	Inquiry No.	Page No.	Inquiry No.	Page No.
2	1st NATIONAL COMPUTER 294	82	COMPONENTS EXPRESS 523	165	EPSON AMERICA 392, 393	*	LOTUS DEVELOPMENT 411
1	SUPER WAREHOUSE 192	83	COMPUADD 520	166	EROS 302	194	LOVEMAN, A.M. 526
3	800 SOFTWARE 149	84	COMPUADD 520	167	ESPRIT SYS. INC. 231	497	LSI JAPAN CO. 566
4	A.S.T.RESEARCH 232, 233	85	COMPUPRO 247	168	EXAR 272, 273	242	LYBEN COMP.SYS. 428
5	AB COMPUTERS 531	*	COMPUPRO 438, 439	169	EXCEL 258	243	LYBEN COMP.SYS. 524
6	ACCOUNTS PAYABLE RESEARCH 422	323	COMPUPRO 440	170	EXPOTEK 245	244	LYGO COMPUTER 423
7	ADDMASTER CORP. 528	86	COMPUSHACK 284, 285	171	EXXON OFFICE SYS.CO. 538	245	MACROTECH INT'L. 90
8	ADV.COMP.PROD. 556, 557	87	COMPUTER APPARATUS 259	503	FACIT DATAROYAL 459	499	MACROTRON SYS. 566
9	ADV.COMP.TECH. 350	88	COMPUTER CHANNEL 338	492	FIGURE LOGIC 542	246	MANNESMANN TALLY 255
10	ADV.DIGITAL CORP. 330	89	COMPUTER DISCOUNT PROD. 539	172	FORMULA INT'L. 529	247	MANX SOFTWARE 24
*	ADV.ELECTRONICS INC. 407	90	COMPUTER EXCHANGE/CONROY-LAPOINT 196, 197	173	FORMULA INT'L. 529	490	MARITIME SOFTWARE ASSOC. 536
12	ADV.LOGIC SYSTEMS 329	91	COMPUTER EXCHANGE/CONROY-LAPOINT 196, 197	174	FOX & GELLER INC. 57	*	MARTIN MARIETTA CORP. 450
13	ADV.PROCESSOR 426	92	COMPUTER EXCHANGE/CONROY-LAPOINT 196, 197	175	FRANKLIN COMP.CORP. 69	248	MARYMAC INDUSTRIES 323
14	ADV.SYS.CONCEPTS 396	93	COMPUTER INNOVATIONS 16	397	FROBCO 100	250	MC NEILL 396
15	AFTERTHOUGHT ENG. 522	94	COMPUTER MAIL ORDER 310, 311	180	G&G ENGINEERING 139	251	MC-P APPLICATIONS 195
16	ALCO SYSTEMS 127	95	COMPUTER OUTLET 554, 555	176	GARDEN OF EDEN COMP. 524	252	MCGRAW-HILL BOOKSTORE 400
*	ALF PRODUCTS, INC. 58	98	COMPUTER PLUS 360	177	GENERAL MICRO SYSTEMS 534	253	MEDIA DISTRIBUTING 158
17	ALPHA BYTE COMP.PROD. 314	96	COMPUTER STORE, THE 538	502	GENERAL SOFTWARE 501	254	MEGABYTE INDUSTRIES 530
18	ALPHA OMEGA COMPUTER 142	99	COMPUTER STORE, THE 540	178	GENIE COMPUTER CORP. 53	*	MEMOREX MEDIA PROD. 101
19	ALTOS COMP.SYS. 115	103	COMPUTER WAREHOUSE 181	*	GENSOFT 390	255	MEMORY MERCHAND 218
20	AMDEK CORP. 11	104	COMPUTERLINE INT'L-A 364, 365	179	GENSTAR REI SALES CO. 526	256	METAPORT, INC. 428
21	AMER BUYING & EXPORT 210	105	COMPUTERLINE INT'L-B 341	180	GIFFORD COMP. SYS. 139	257	METASOFT CORP. 427
22	AMER.MITAC CORP. 169	107	COMPUTERS AND MORE 226	181	GILTRONIX INC. 524	258	METHOD SYSTEMS 522
23	AMER.SQUARE COMP. 147	108	COMPUVIEW PROD.INC. 65	182	GLADSTONE ELECTRONICS 248	260	MICRO BUSINESS WORLD 354
24	ANCHOR 60	109	COMREX 79	183	GLOUCESTER COMP.BUSN.CO. 540	*	MICRO COMPUTER CO. INC. 391
25	APPARAT INC. 151	110	CONCORD COMP.PROD. 521	186	GOLDEN WEST SYSTEMS 536	324	MICRO MAIL 525
26	APPLE COMPUTER INC. CII, 1	111	CONCURRENT CORP. 452	187	GOODWILL ELECTR.CO. 540	261	MICRO MANAGEMENT SYS. 269
28	APPLE COUNTRY LTD. 523	112	CONTROL DATA 249	188	GREAT SALT LAKE COMP. 544, 545	483	MICRO MINT 346
29	APPLEWARE, INC. 530	114	CONTROL ELECTRONICS, INC. 116	189	GTEK INC. 248	262	MIRCO MINT 453
30	APPLIED ANALYTICS 415	116	CORONA DATA SYS. 184, 185	190	H.H.S. MICROCONTROLLERS 524	263	MICRO SCI 178
31	ARBUSUTUS TOTALSOFT INC. 534	116	CORONA DATA SYS. 335, 336, 337	191	HAYES MICROCOMP.PROD. 120, 121	264	MICRO SOLUTIONS 520
32	ARK MICROSYSTEMS 230	117	COST PLUS COMP. 538	480	H&E COMPUTRONICS 43	265	MICRO WORKS, THE 200
33	ARTIFICIAL INT'L.RESRCH. 528	118	CREATIVITY UNLTD. 520	193	HEATH COMPANY 71	266	MICRO XPRESS 416
34	ASHTON-TATE 56	119	CROMEMCO 5	305	HEWLETT-PACKARD 103	259	MICROAGE COMP.STORE 383
35	ASHTON-TATE 322	121	CUESTA SYSTEMS 536	45	HOUSTON INSTR.DIV. OF BAUSCH & LOMB 223	268	MICRODYNAMICS 426
36	ASHTON-TATE 344, 345	122	CUSTOM COMP.TECH. 543	195	HUMAN DESIGNED SYS. 111	269	MICROHOUSE 73
37	ASHTON-TATE 351	123	CUSTOM MICRO SYS.LTD. 428	196	HUMAN SOFT 229	270	MICROPERIPH.CORP.THE 530
38	ASPEN SFTW.CO. 204	*	CYBERNETICS INC. 87	197	I.T.M. 251	489	MICROPROCESSORS UNLTD. 536
*	AT & T LONG LINES 437	124	CYBERNETICS MICRO SYS. 534	198	IBM CORP. 80, 81	271	MICROPRO INT'L. 356,357
*	AUTOMATED EQUIPMNT. 527	184	CYBERTEK 542	199	IBM SYSTEMS SUPPLY DIV. 449	*	MICROSOFT (CPD) 153
39	AVOCET 379	125	DALTECH MICROSYSTEMS 422	192	IBS COMPUTERTECHNIK 391	*	MICROSOFT (CPD) 108, 109
41	B&B ELECTR. 520	126	DATA ACQUISITIONS SYS. 77	200	IDE CORPORATION 240, 241	272	MICRO-TAX 83
41	B&B ELECTR. 542	127	DATA DISTRIBUTING ENT. 520	201	IMAGE COMP.PROD. 540	273	MICROTECH EXPORTS 238
42	BALCONES COMP.CORP. 369	209	DATA MAIL 353	202	IMS INTERNATIONAL 29	274	MICROTOPY 534
43	BARGAIN BOARDS 522	128	DATAMASTER 534	432	INCOMM 540	275	MICROWARE 358
44	BASF SYSTEMS 107	129	DATAPRITE 426	203	INCOMM 94	276	MILLER MICROCOMP.SERV. 414
44	BASIS, INC. 250	130	DATASOURCE SYS.MRKTG. 446	204	INSIGHT ENTERPRISES 538	277	MINISUBA 50
46	BAY TECHNICAL ASSOC. 92	131	DATASOUTH COMP.CORP. 143	205	INT'L COMP. & TELECOM.INC. 542	300	MONITOR COMPUTING 482
47	BELL, JOHN ENGR. 534	132	DATASOUTH COMP.CORP. 436	206	INTEGRAL DATA SYS. 367	278	MORROW DESIGNS 376, 377
*	BELL LABS 343	133	DATATEK 522	207	INTEGRAND 300	279	MORROW DESIGNS 417
48	BETSY BYTES 528	134	DELUXE COMP.FORMS 51	208	INTEL CORP. 211	280	MOUNTAIN VIEW PRESS 227
49	BHRT 252, 253	306	DENNISON KYBE 215	209	INTERACTIVE MICROWARE 476	281	MTI SYSTEMS CORP. 130
50	BINARY TECHNOLOGY 526	135	DHD 522	210	INTERACTIVE STRUCT. 173	282	MULTITECH ELECT. 191
51	BMC U.S.A. 193	136	DHL WORLDWIDE COURIER 441	211	INTERCONTRONICS 313	*	MUSYS 201
51	BMC U.S.A. 193	137	DIAMOND SFTW.SUPPLY 262	212	INTERDATA SYSTEMS INC. 542	283	NCL DATA INC. 236
52	BOTTOM LINE, THE 205	138	DIGISOFT COMPUTER 381	213	INTERTEC DATA SYS. 14, 15	284	NEC HOME ELECTR.USA 89
*	BRYLAR 536	139	DIGITAL DIMENSIONS 194	214	INTERTEC DATA SYS. 14, 15	285	NEC HOME ELECTR.USA 91
54	BUSINESS MANAGER 375	140	DIGITAL ELECT.SYS. 128	215	IRONSIDES COMP. CORP. 275	*	NETRONICS 176
55	BYTE INDUSTRIES 206	141	DIGITAL EQUIPMENT CORP. 17	495	IVIE COMPUTER 566	*	NETWORK CONSULTING INC. 225
*	BYTE BACK ISSUES 374	142	DIGITAL EQUIPMENT CORP. 321	216	J.C.SYSTEMS 162	287	NEW MEDIA GRAPHICS 524
*	BYTE PUBL. INC. 470	143	DIGITAL MARKETING 10	217	J.F.ELECTRIC 530	*	NORTH HILLS CORP. 522
56	BYTEC HYPERION 105	481	DIGITAL MEDIA 536	218	JADE COMP.PROD. 546, 547	*	NORTH HILLS CORP. 528
57	BYTEK COMP.SYS.CORP. 489	145	DIGITAL RESEARCH 33	219	JAMECO ELECTR. 558, 559	288	NORTHWEST DIGITAL SYS. 174
58	BYTEWRITER 12	146	DIGITAL RESEARCH 32 A-H	*	JAMES FOX ASSOC. 566	289	NOVELL INC. 333
59	C-SYSTEMS 150	147	DIGITAL RESEARCH COMP. 326	220	JDR MICRODEVICES 567	290	O'HANLON COMP.SYS. 397
60	C-WARE CORP. 382	148	DISCOUNT SOFTWARE 220, 221	221	JDR MICRODEVICES 568, 569	291	ONTAGON COMP.SYS. 296, 297
61	C.S.D.INC. 536	149	DISPLAYED VIDEO 537	222	JDR MICRODEVICES 570, 571, 572	292	OLYMPIC SALES 325
62	CALIF. DATA CORP. 528	304	DMA 319	223	JUKI INDUSTRY OF AM 257	293	OMEGA INFO SYS. 422
*	CALIF. DIGITAL 552, 553	149	DOKAY COMP.PROD.INC. 550, 551	224	JVB ELECTRONICS 422	294	OMNI RESOURCES 361
*	CALIF.MICRO.CORP. 360	150	DOW JONES SOFTWARE 327	225	K&R COMPUTER CO.LTD. 538	*	ORA ELECTRONICS 535
63	CANON U.S.A. 217	97	DIPUNCH 412	226	KADAK PRODUCTS 387	296	ORION INSTRUMENTS 534
*	CDEX 113	151	DUAL SYSTEMS CORP. 295	227	KADAK PRODUCTS 267	297	ORIX SOFTWARE 429
65	CDR SYSTEMS 534	152	DWIGHT CO. INC. 530	228	KENSINGTON MICROWARE 228	298	OSBORNE/MCGRAW-HILL 239
66	CENTRE COMP.CONSULTANTS 422	153	DYSAN CORP. 85	229	KERN PUBLISHING 308	*	OWENS & ASSOC. 288
67	CHECK-MATE 320	154	EZ ASSOC. 524	230	KERN PUBLISHING 309	*	PACIFIC COMPUTERS 410
68	CHIPS & DALE 522	155	EAST SIDE SOFTWARE 349	231	KEY TRONIC CORP. 305	299	PACIFIC EXCHANGES 524, 526, 530, 534, 536, 538, 540, 542
69	CHRISLIN INDUSTRIES 359	156	EASTERN ENTERPRISES 246	232	KEY SOFTWARE 422	485	PAN AMERICAN ELEC.INC. 350
70	CIPHER DATA PRODUCTS 49	157	ECONOMY PERIPH. 540	233	LABORATORY MICROSYS. 530	488	PANEL GRAPHICS 254
71	CITICORP LATINO 538	158	ECOSOFT 78	234	LANGLEY-ST.CLAIR 152	307	PARAGRAPHS 530
72	CLEO 431	159	EDUCATIONAL MICROCOMP. 530	235	LANIER BUSN.PROD. 179	308	PC TECHNOLOGY 380
72	CMC,INT'L. 199	160	ELECTRONIC PROTECTION DEV 242	236	LEADING EDGE PROD. CIII	309	PEP BUSINESS SYSTEMS 267
74	COGITATE 526	161	ELECTRONIC SPLISTS 355	237	LIBERTY COMP. SALES 419	310	PER SCI INC. 526
75	COLN, JAMES M. & ASSOC. 520	*	ELLIS COMPUTING 131	238	LIGO RESEARCH INC. 263	311	PERCOM DATA 9
76	COLONIAL DATA SERV. 399	*	EMPIRICAL RESRCH.GRP. 136	239	LOGICAL DEVICES 13	312	PERSONAL SYS.TECH. 170, 171
77	COLORADO COMP.PERIPH. 428	163	ENGINEERING SPECIALTIES 542	240	LOGICAL MICROCOMPUTER 307	314	PH ASSOCIATES 78
78	COLUMBIA DATA PROD. 234	164	ENTER COMPUTER 266	241	LOMAS DATA PRODUCTS 203	482	PHACT ASSOC. 150
79	COMMUNICATIONS ELECTR. 541					315	PHASER 125
80	COMP.COMPNTS.UNLTD. 548, 549					316	PHONE 1 129
80	COMP. WHOLESALEERS OF FREDERICK 476					317	PION INC. 318
81	COMPAQ COMP. CORP. 165					318	PLUM HALL INC. 182

To get further information on the products advertised in BYTE, fill out the reader service card with your name and address. Then circle the appropriate numbers for the advertisers you select from the list. Add a 20-cent stamp to the card, then drop it in the mail. Not only do you gain information, but our advertisers are encouraged to use the marketplace provided by BYTE. This helps us bring you a bigger BYTE. The index is provided as an additional service by the publisher, who assumes no liability for errors or omissions. *Correspond directly with company.

Reader Service

Inquiry No.	Page No.	Inquiry No.	Page No.	Inquiry No.	Page No.	Inquiry No.	Page No.
325	PROGRAMMERS SFTW. EX. 68	*	SILICON SPECIALTIES 137	380	TAURUS COMP.PROD.INC. 32	409	VAN DATA 146
326	PROGRAMMING INT'L. 132, 133	357	SLR SYSTEMS 528	382	TAYCO BUSINESS FORMS 528	410	VAN DATA 244
327	PROGRAMMING INT'L. 156, 157	358	SLUDER/COMPETITIVE EDGE 155	391	TDI 28	411	VICTOR TECHNOLOGIES 281
328	PROXIMITY DEVICES CORP. 70	359	SOFTECH MICROSYS 271	383	TECH-DATA CORP. 524	412	VIDEX 19
329	PURCHASING AGENT, THE 104	360	SOFTWARE BANC SEMINARS 25	384	TEKTRONIX INC. 95	413	VIDIOM IMPORTS 540
330	QUADRAM CORP. 34, 35	361	SOFTWARE BANC 175	302	TELECON SYSTEMS 202	414	VISUAL TECH, INC. 207
331	QUADRAM CORP. 61	362	SOFTWARE GUILD 370, 371	365	TELETEK ENTERPRISES 55	415	VLM COMPUTER ELEC. 426
332	QUADRAM CORP. 208, 209	363	SOFTWARE RESEARCH CORP. 538	388	TELEVIDEO INC. 62, 63	486	VOTRAX 447
427	QUBIE 164	364	SOFTWARE SERVICES 520	496	TERMINALS DATA 566	416	VR DATA 421
333	QUELO 528	365	SOFTWARE TOOLWORKS 380	387	TERMINALS TERRIFIC 54	417	WADSWORTH ELECTRONIC PUBL. 363
334	R.C. ELECTRONICS 189	*	SORCIM 97	388	TEXAS COMP.SYS. 405	*	WAREHOUSE SOFTWARE 180
335	R.C. ELECTRONICS 189	*	SOURCE EDP 424, 425	369	TEXAS INSTR. 144, 145	419	WASHINGTON COMP.SERV. 315
336	RADIO SHACK CIV	367	SOUTHWATER CORP. 428	390	THINKERS SOFT INC. 352	420	WASHINGTON COMP.SERV. 210
337	RANA SYSTEMS 44, 45	368	SPECIALIZED SYS.CON-SULTANTS 520	392	TINNEY, ROBERT GRAPHICS 451	421	WHITESMITHS LTD. 159
339	RCA 316, 317	369	STAR MICRONICS 287	301	TOSHIBA AMERICA INC. 260, 261	422	WILLIAMS, MARK CO. 277
341	RING KING VISIBLES, INC. 18	27	STEMMOS 455	393	TRANSACTION STORAGE SYS. 177	423	WINTERKORP. 526
342	RM DISTRIBUTORS 526	370	STREET ELECTR CORP 433	394	TRANSTAR 161	424	WINTERHALTER & ASSOC. INC. 382
343	ROCKY MT.MICRO INC. 299	371	STUART SOFTWARE 426	395	TRANSTAR 385	425	WORLDWIDE COMP.SUPPLIES 522
344	RTL PROGRAMMING AIDS 524	372	SUNDEX 420	396	TRANSTAR 435	426	WORSWICK INDUSTRIES 538
345	S&W COMPUTER SUPPLY 522	373	SUNTRONICS 521	500	TRIANGLE SFTW. 566	428	X COMP 279
346	S-100 DIV. 696 CORP. 304	373	SUPERSOFT 301	398	TRISTRAR DATA SYS. 219	429	XEROX 118, 119
352	S-100 DIV. 696 CORP. 256	374	SUPERSOFT 301	399	TSK ELECTR.CORP. 163	*	XL SYSTEMS 426
487	SAFEWARE 502	375	SWI INT'L. 395	400	U.S. MICRO SALES 291	*	XPER SYSTEMS 75
347	SAGE COMP.TECH. 93	374	SYSTEM VISION CORP. 219	401	U.S. MICRO SALES 532, 533	431	YANG ELECTR. SYS. 540
348	SAKATA 26	375	SYSTEMS GROUP, THE 389	402	U.S. ROBOTICS 30	484	YIELD HOUSE 368
349	SATURN SYSTEMS INC. 289	498	SYSTEMS PROD. EXCHANGE 568	404	U.S. EXCHANGE 566	433	ZOBEX 187
*	SCOTTS DALE SYSTEMS 282	376	TALLGRASS TECH. 59	494	U.S. EXCHANGE 542		
491	SCREENWARE 542	377	TALMIS CORP. 373	405	UNIFIED SOFTWARE SYS. 528		
351	SD SYSTEMS 183	378	TARBELL ELECTR. 355	406	UNIPRESS 214		
353	SEEQUA COMP.CORP. 6	379	TATUM LABS 526	407	UNITED COMPUTER 117		
185	SEKON INT'L CORP. 295			408	UNIVERSAL DATA SYS 31		
354	SEMI DISK SYSTEMS 27						
355	SIERRA DATA SCIENCES 20, 21						

*Correspond directly with company.

BYTE ADVERTISING SALES STAFF:

J. Peter Huestls, Advertising Sales Manager, 70 Main Street, Peterborough, N.H. 03458 Tel (603) 924-9281

NEW ENGLAND

ME, NH, VT, MA, RI
Paul McPherson, Jr. (617) 262-1160
McGraw-Hill Publications
607 Boylston Street
Boston, MA 02116

ATLANTIC

NJ (NORTH), NY, NYC, CT
Eugene Duncan (212) 997-2096
McGraw-Hill Publications
1221 Ave of the Americas - 39th Floor
New York, NY 10020

Dick McGurk (212) 997-3588

McGraw-Hill Publications
1221 Ave of the Americas - 39th Floor
New York, NY 10020

EAST

PA (EAST), NJ (SOUTH), MD, VA, W. VA, DE, D.C.
Daniel Ferro (215) 496-3833
McGraw-Hill Publications
Three Parkway
Philadelphia, PA 19102

SOUTHEAST

NC, SC, GA, FL, AL, TN,
Maggie McClelland (404) 252-0626
McGraw-Hill Publications
4170 Ashford Dunwoody Road - Suite 420
Atlanta, GA 30319

MIDWEST

IL, MO, KS, IA, ND, SD, MN, WI, NB
Jack Anderson (312) 751-3740
McGraw-Hill Publications
Blair Building
645 N. Michigan Ave
Chicago, IL 60611

GREAT LAKES, OHIO REGION

MI, OH, PA (ALLEGHENY), KY, IN,
EASTERN CANADA
Dennis Riley (313) 352-9760
McGraw-Hill Publications
4000 Town Center - Suite 770
Southfield, MI 48075

SOUTHWEST, ROCKY MOUNTAIN

UT, CO, WY, OK, TX, AR, MS, LA
Alan Morris (214) 458-2400
McGraw-Hill Publications
Prestonwood Tower - Suite 907
5151 Beltline
Dallas, TX 75240

SOUTH PACIFIC

Southern CA, AZ, NM, LAS VEGAS
Page Goodrich (714) 557-6292
McGraw-Hill Publications
3301 Red Hill Ave
Building #1, Suite 222
Costa Mesa, CA 92626

Karen Niles (213) 480-5243, 487-1160

McGraw-Hill Publications
3333 Wilshire Boulevard #407
Los Angeles, CA 90010

NORTH PACIFIC

HI, WA, OR, ID, MT, NORTHERN CALIF,
NV (EXCEPT LAS VEGAS) W. CANADA
David Jern (415) 362-4600
McGraw-Hill Publications
425 Battery St.
San Francisco, CA 94111

Bill McAfee (415) 964-0624

McGraw-Hill Publications
1000 Elwell Court - Suite 225
Palo Alto, CA 94303

WEST COAST SURPLUS AND RETAIL ACCOUNTS

Tom Harvey (805) 964-8577
3463 State St. - Suite 256
Santa Barbara, CA 93105

Post Card Mailings

National
Bradley Browne (603) 924-9281
BYTE Publications
70 Main Street
Peterborough, N.H. 03458

International Advertising Sales Representatives:

Mr. Hans Csokor
Publimedia
Reisnerstrasse 61
A-1037 Vienna, Austria

Mrs. Gurit Gepner
McGraw-Hill Publishing Co.
115 Yosephthal St.
Bat Yam, Israel
866 561 321 39

Mr. Fritz Krusebecker
McGraw-Hill Publishing Co.
Liebigstrasse 27C
D-6000 Frankfurt/Main 1
West Germany
72 01 81

Mrs. Maria Sarmiento
Pedro Teixeira 8, Off. 320
Iberia Mart 1
Madrid 4, Spain
45 52 891

Mr. Andrew Karnig
Andrew Karnig & Associates
Kungsholmsgatan 10
112 27 Stockholm, Sweden
08 51 68 70

Mr. Michael Sales
McGraw-Hill Publishing Co.
17 rue Georges Bizet
F 75116 Paris
France
720 33 42

Mr. Arthur Scheffer
McGraw-Hill Publishing Co.
34 Dover St.
London W1X 3RA
England
01 493 1451

Mr. Elio Gonzaga
McGraw-Hill Publishing Co.
Via Baracchini 1
20123 Milan, Italy
86 90 617

Seavex Ltd.
05-49/50 Tanglin Shopping Center
19 Tanglin Rd. Singapore 1024
Republic of Singapore

Seavex, Ltd.
Room 102, Yu Yuet Lai Bldg.
43-55 Wyndham St. Central
Hong Kong

Nikkel/McGraw-Hill Publishing Co
Nikkel Annex Bldg
2-1-2 Uchikanda
Chiyoda-Ku
Tokyo, Japan

History will record as a profound irony
that the most powerful word processing package
ever created for the IBM® Personal Computer
wasn't created by IBM.

LEADING EDGE.®

Leading Edge Products Inc., Fortune 1300 Division, 21 Highland Circle, Needham Heights, Mass. 02194 (800) 343-3436 (617) 449-6762
Headquarters and Retail Division, 225 Turnpike Street, Canton, Mass. 02021 (800) 343-6833 (617) 828-8150

*IBM is a registered trademark of International Business Machines Corporation.

Circle 236 on Inquiry card.

Radio Shack's Model 100 is the Portable TRS-80® That Communicates With Your Micro, Mini or Mainframe!

(And It's the Only Computer With Five Built-In Programs!)



8K TRS-80 Model 100

799⁰⁰

26-3801

Only \$45 Per Month
On CitiLine Credit

24K TRS-80 Model 100

999⁰⁰

26-3802

Only \$56 Per Month
On CitiLine Credit

A Workstation That Goes Where You Go. The TRS-80 Model 100 Portable Computer offers advanced communications features and powerful built-in, "instant-on" software to make it the perfect traveling companion. Its ROM-based programs let you use Model 100 as a personal word processor, telephone auto-dialer, address book, appointment calendar and information terminal.

Complete Telecommunications Package. When you're away from the office, use Model 100's built-in auto-dial modem to send text files to your office computer with just a few keystrokes. Set up an auto log-on function to quickly and easily access major information networks. You can even download data to the Model 100.

Complete Interface Capability. In the office, connect the Model 100 directly to your computer—be it micro, mini or mainframe—using the RS-232C interface. Then transfer data at up to 19,200 baud. Get fast printouts by connecting the Model 100 to a printer via the parallel interface. And there's an interface for saving or loading programs, data and text at 1500 baud using a standard cassette recorder.

Advanced BASIC Language. Extended Microsoft® BASIC offers full string handling, complete file operations, multi-dimension arrays, 14-digit double-precision accuracy and more.

Find Out More! See the Model 100 at your nearest Radio Shack Computer Center, participating store or dealer.

Radio Shack®

The biggest name in little computers®

A DIVISION OF TANDY CORPORATION

Prices apply at participating Radio Shack stores and dealers.
Microsoft is a registered trademark of Microsoft Corp.

Circle 336 on inquiry card.

www.americanradiohistory.com